

# Application Note AN-1104

## IRS2104 and IR2104 Comparison

*By Jason Nguyen, Min Fang, David New*

### Table of Contents

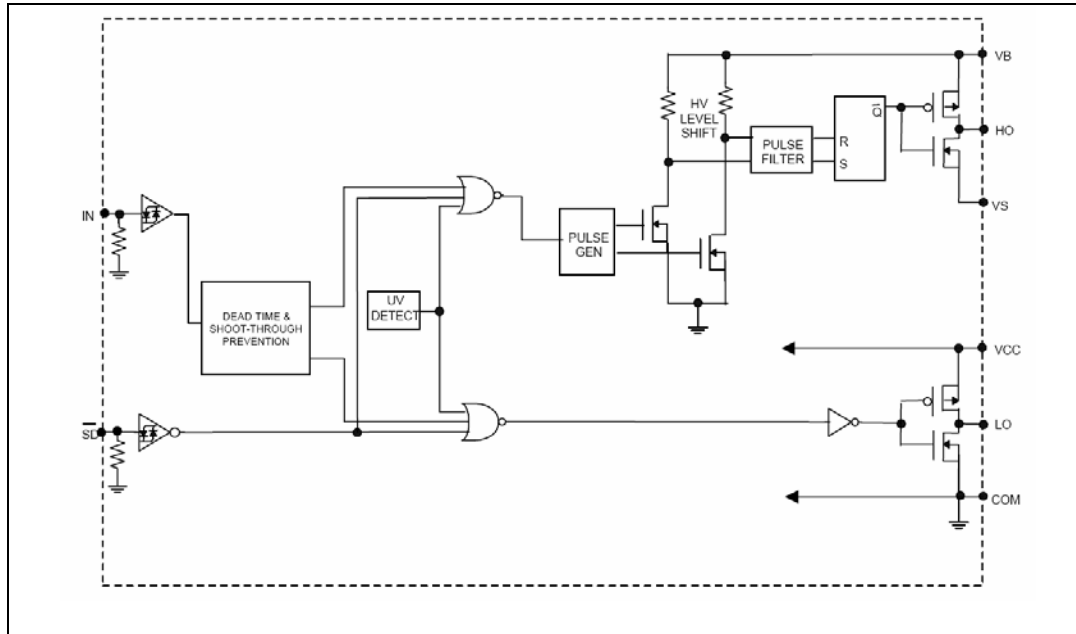
	<b>Page</b>
Introduction .....	1
Block Diagram.....	2
Electrical Characteristic Differences.....	2
Figures .....	3
Summary.....	8

### Introduction

The IRS2104 is a new HVIC product that replaces the IR2104 and is pin-to-pin compatible with its corresponding predecessor. In many cases, little or no change is necessary to use the new product. This application note describes the various differences between the IRS2104 and the IR2104 HVICs.

The IRS2104 is a high voltage, high speed power MOSFET and IGBT driver with independent high and low side referenced output channels. Proprietary HVIC and latch immune CMOS technologies enable ruggedized monolithic construction. The logic input is compatible with standard CMOS or LSTTL outputs, down to 3.3 V logic. The output drivers feature a high pulse current buffer stage designed for minimum driver cross-conduction. The floating channel can be used to drive an N-channel power MOSFET or IGBT in the high side configuration which operates up to 600 V.

### Block Diagram



The IRS2104 and the IR2104 share the same block diagram. The functionality of the two ICs is the same.

### Electrical Characteristic Differences

All measurement conditions remain unchanged unless noted. Parameters not mentioned in this document have not changed.

#### Absolute Maximum Ratings

There are no changes in the Absolute Maximum Ratings.

#### Recommended Operating Conditions

There are no changes in the Recommended Operating Conditions.

### Dynamic Electrical Characteristics

Parameter		IR2104		IRS2104		Units
Symbol	Definition	typ	max	typ	max	
$t_r$	Turn-on rise time	100	170	70	170	ns
$t_f$	Turn-off fall time	50	90	35	90	

The IRS2104 has faster rise and fall times when compared to the IR2104.

### Static Electrical Characteristics

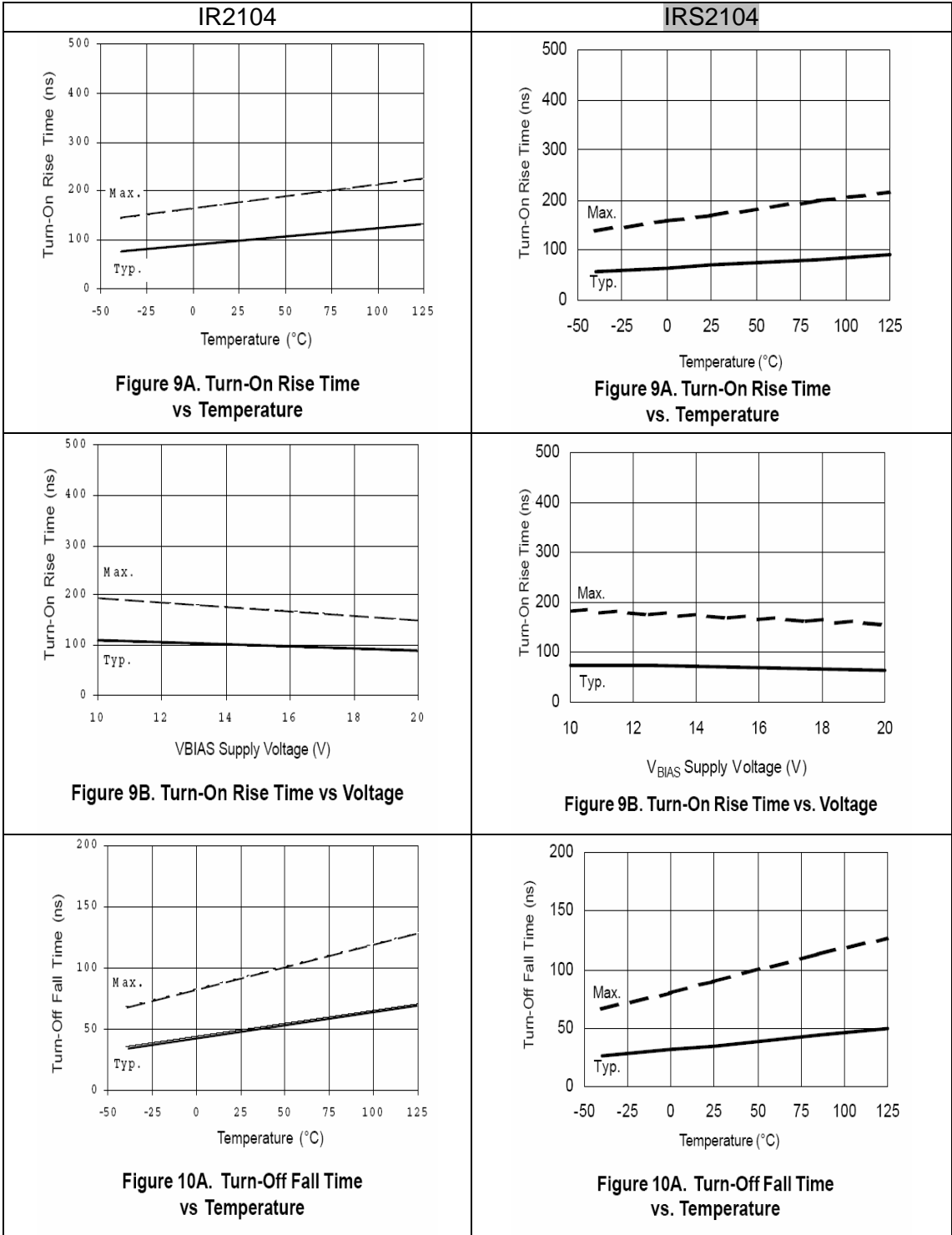
Parameter		IR2104			IRS2104			Units
Symbol	Definition	min	typ	max	min	typ	max	
$V_{IH}$	Logic "1" input voltage ( $V_{CC} = 10\text{ V to }20\text{ V}$ )	3	-	-	2.5	-	-	V
$V_{IL}$	Logic "0" input voltage ( $V_{CC} = 10\text{ V to }20\text{ V}$ )	-	-	0.8	-	-	0.8	
$V_{SD,TH+}$	SD input positive going threshold	3	-	-	2.5	-	-	
$V_{SD,TH-}$	SD input negative going threshold	-	-	0.8	-	-	0.8	
$V_{OH}$	High level output voltage, $V_{BIAS} - V_O$	-	-	0.1	-	0.05	0.2	
$V_{OL}$	Low level output voltage, $V_O$	lo = 0 mA			lo = 2 mA			
		-	-	0.1	-	0.02	0.1	
$I_{O+}$	Output high short circuit pulsed current ( $V_O = 0\text{ V}$ , $V_{IN} = \text{Logic "1"}$ , $PW \leq 10\mu\text{s}$ )	lo = 0 mA			lo = 2 mA			
		130	210	-	130	290	-	mA
$I_{O-}$	Output low short circuit pulsed current ( $V_O = 15\text{ V}$ , $V_{IN} = \text{Logic "0"}$ , $PW \leq 10\mu\text{s}$ )	270	360	-	270	600	-	

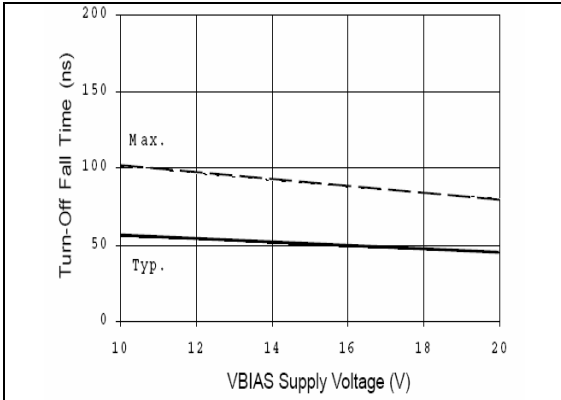
For the IRS2104,

1. The  $V_{IH}$  and  $V_{SD, TH+}$  are reduced to 2.5 V for better 3.3 V logic compatibility.
2. The  $V_{OH}$  and  $V_{OL}$  are tested using a new standardized test condition of  $I_{O+} = 2\text{ mA}$ . The output driver's on resistance is lower for IRS2104, which improves immunity against the Miller effect.
3. The typical values for  $I_{O+}$  and  $I_{O-}$  are increased, which allows faster switching.

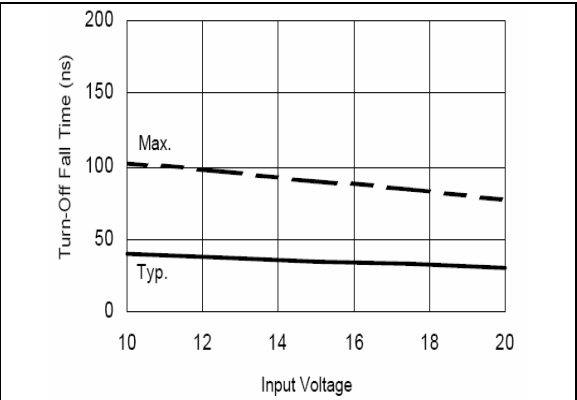
### Figures

This figures shown in this section compare figures shown in the IR2104 (left column) and IRS2104 (right column) datasheets. Illustrations that have not changed between the two datasheets have not been included in this section.

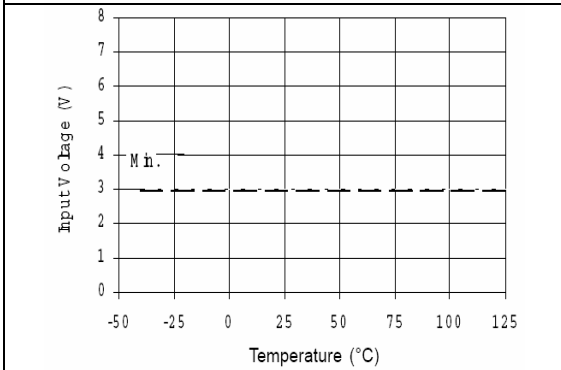




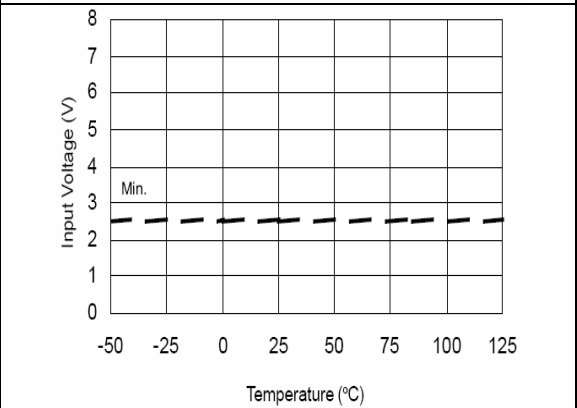
**Figure 10B. Turn-Off Fall Time vs Voltage**



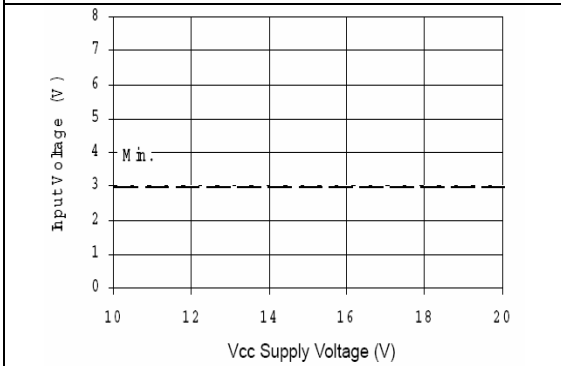
**Figure 10B. Turn-Off Fall Time vs. Input Voltage**



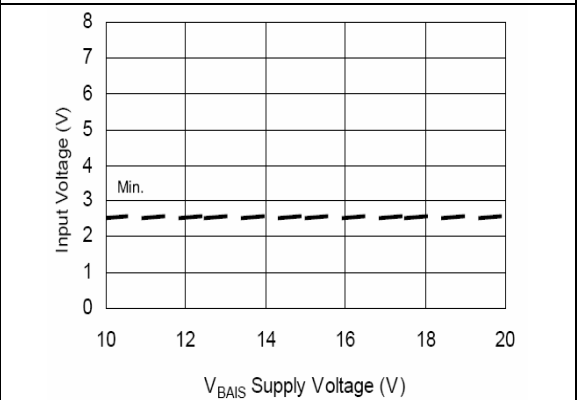
**Figure 12A. Logic "1" (HO) & Logic "0" (LO) & Inactive SD Input Voltage vs Temperature**



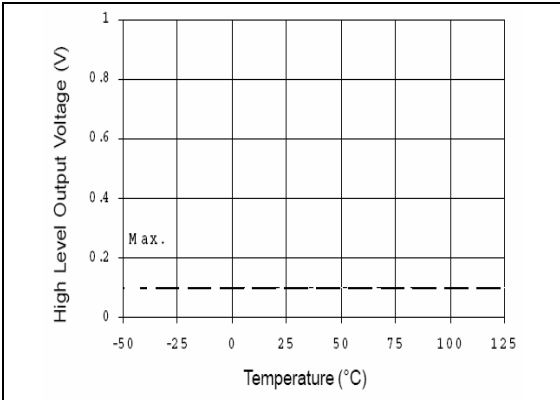
**Figure 12A. Logic "1" Input Voltage vs. Temperature**



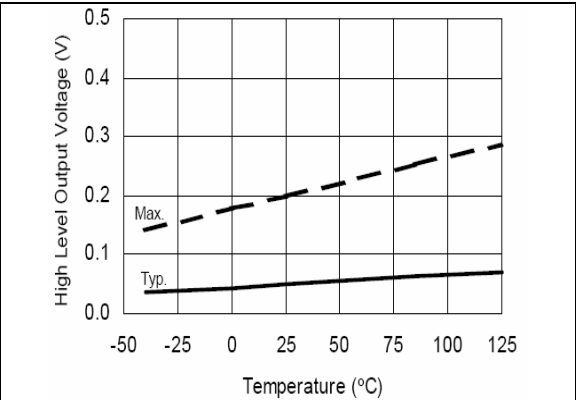
**Figure 12B. Logic "1" (HO) & Logic "0" (LO) & Inactive SD Input Voltage vs Voltage**



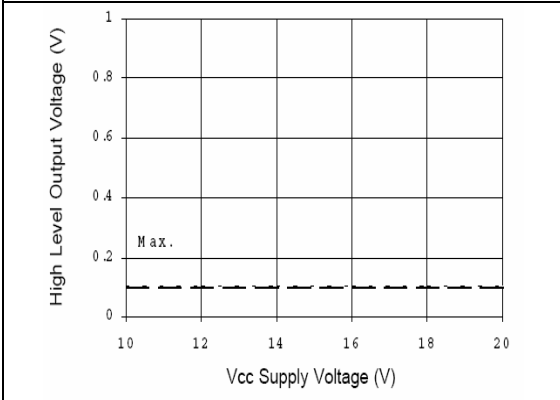
**Figure 12B. Logic "1" Input Voltage vs. Supply Voltage**



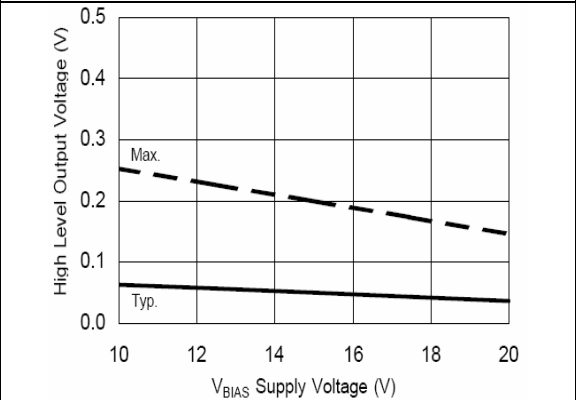
**Figure 14A. High Level Output vs Temperature**



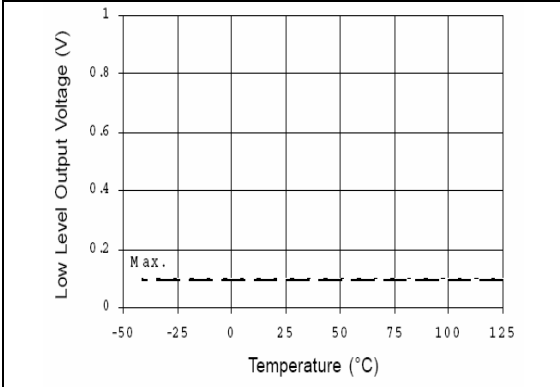
**Figure 14A. High Level Output Voltage vs. Temperature**



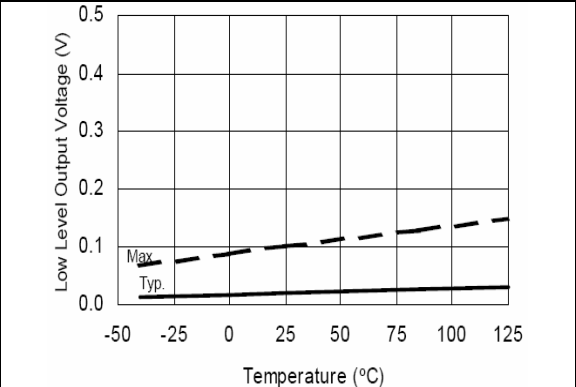
**Figure 14B. High Level Output vs Voltage**



**Figure 14B. High Level Output Voltage vs. Supply Voltage**



**Figure 15A. Low Level Output vs Temperature**



**Figure 15A. Low Level Output Voltage vs. Temperature**

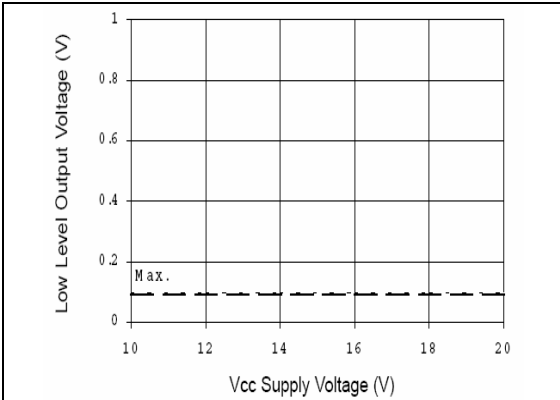


Figure 15B. Low level Output vs Voltage

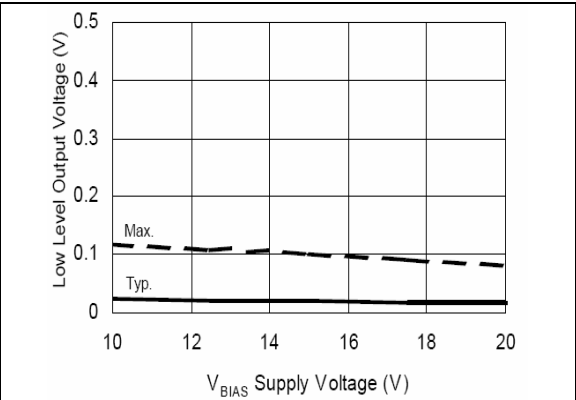


Figure 15B. Low Level Output Voltage vs. Supply Voltage

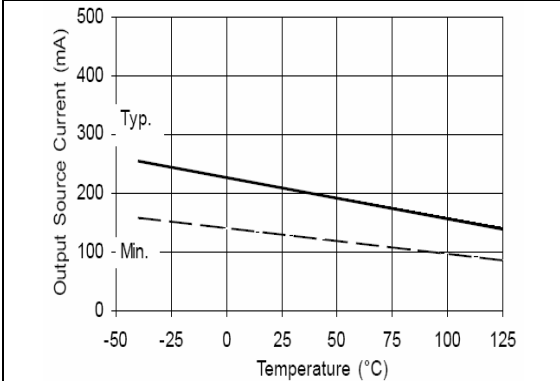


Figure 22A. Output Source Current vs Temperature

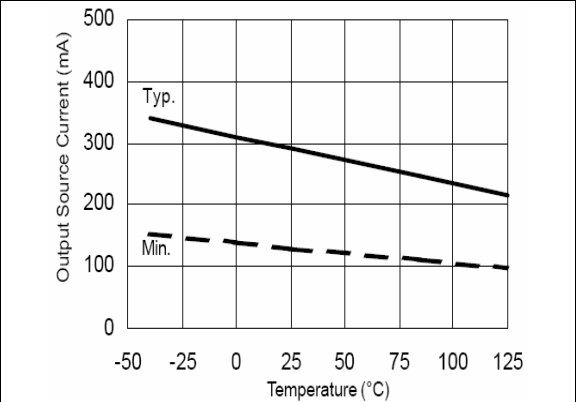


Figure 22A. Output Source Current vs. Temperature

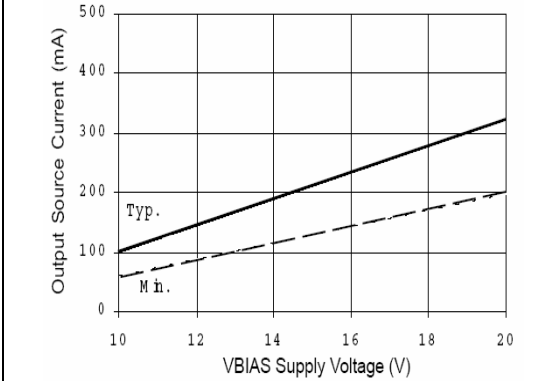


Figure 22B. Output Source Current vs Voltage

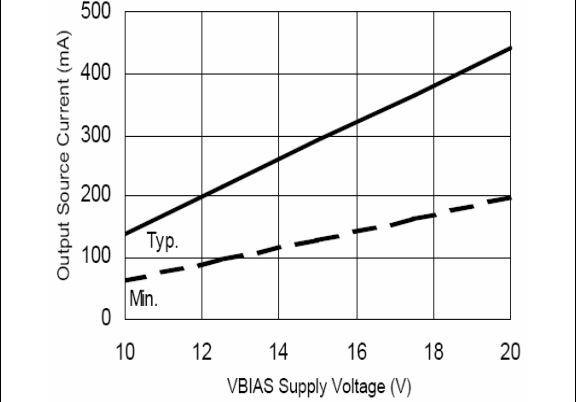
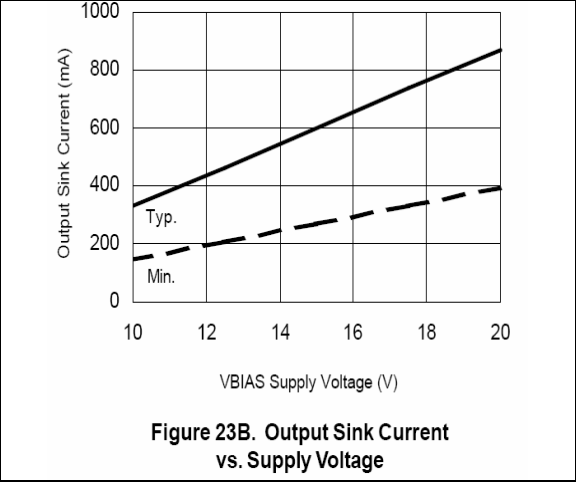
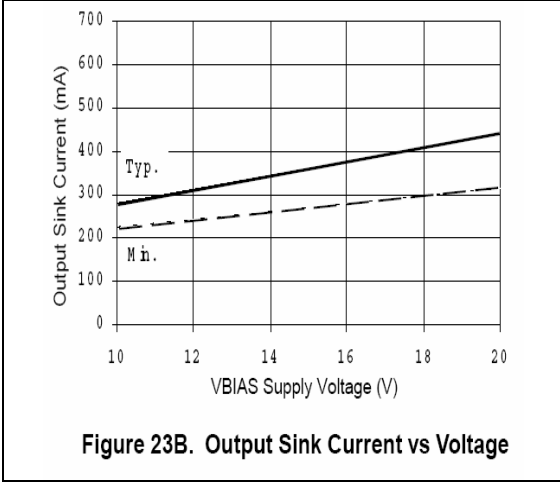
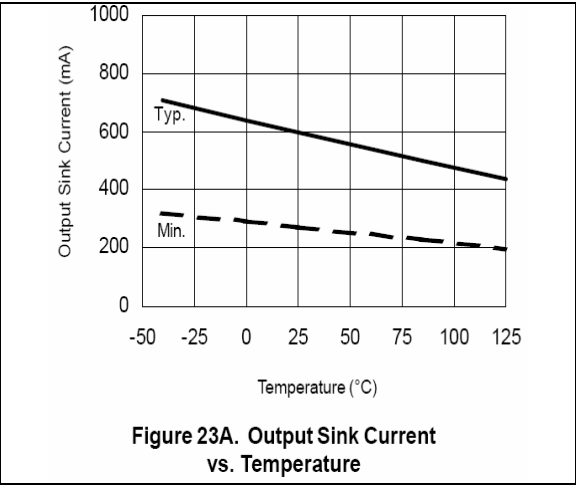
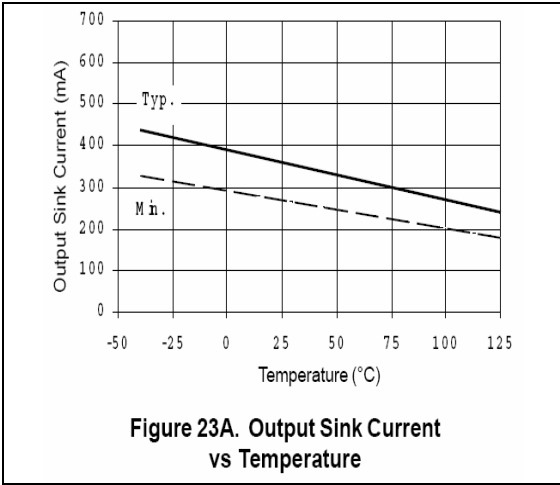


Figure 22B. Output Source Current vs. Voltage



## Summary

As shown by this document, the IRS2104 and the IR2104 are very similar with only a few negligible parametric differences.