

IR3846A OptiMOS™ IPOL

40 A single-voltage synchronous Buck regulator

Features

- Single 4.3 V to 17 V application or Wide Input Voltage Range from 2 V to 17 V with external VCC
- Precision Reference Voltage (0.6 V +/-0.5%)
- Enhanced Fast COT engine stable with Ceramic Output Capacitors and No External Compensation
- Switching Frequency of 600 kHz with Forced Continuous Conduction Mode
- Enable input with Voltage Monitoring Capability & Power Good Output
- Monotonic Start-Up with 1 ms soft start time
- Thermally compensated Internal Over Current Protection with two Selectable Settings
- Enhanced Pre-Bias Start up
- Thermal Shut Down
- Operating Junction Temp: $-40\text{ }^{\circ}\text{C} < T_j < 125\text{ }^{\circ}\text{C}$
- Small Size: 5 mm x 7 mm PQFN
- Halogen-free and RoHS2 Compliant with Exemption 7a

Potential applications

- Server Applications
- Storage Applications
- Telecom & Datacom Applications
- Distributed Point of Load Power Architectures

Product validation

Qualified for industrial applications according to the relevant tests of JEDEC47/20/22

Description

The IR3846A is an easy-to-use, fully integrated dc - dc Buck regulator. The onboard PWM controller and OptiMOS™ FETs with integrated bootstrap diode make IR3846A a small footprint solution, providing high-efficiency power delivery. Furthermore, it uses a fast Constant On-Time (COT) control scheme, which simplifies design efforts and provides fast control response.

The IR3846A has an internal low dropout voltage regulator, allowing operation with a single supply. It can also operate with an external bias supply, extending the operating input voltage (PVIN) range. The IR3846A offers a switching frequency of 600 kHz, two selectable current limits, soft start time of 1 ms, and Forced Continuous Conduction Mode (FCCM).

It also features important protection functions, such as pre-bias start-up, thermally compensated current limits, over voltage and under voltage protection, and thermal shutdown to give required system level security in the event of fault conditions.

Table of contents

Features 1

Potential applications 1

Product validation 1

Description 1

Table of contents 2

1 Ordering information 4

2 Functional block diagram..... 5

3 Typical application diagram 6

4 Pin descriptions 7

5 Absolute maximum ratings 9

6 Thermal Characteristics10

6.1 Thermal Characteristics 10

7 Electrical specifications11

7.1 Recommended operating conditions..... 11

7.2 Electrical characteristics 12

8 Typical efficiency and power loss curves.....14

8.1 $P_{VIN} = V_{IN} = 12\text{ V}$, $F_{sw} = 600\text{ kHz}$, Mode: FCCM..... 14

9 Thermal de-rating cuves15

10 $R_{DS(ON)}$ of MOSFET over temperature16

11 Typical operating characteristics ($-40\text{ °C} \leq T_j \leq +125\text{ °C}$)17

12 Theory of operation.....19

12.1 Fast Constant On-Time Control 19

12.2 Enable 19

12.3 FCCM Operation 20

12.4 Pseudo-Constant Switching Frequency 20

12.5 Soft-start..... 20

12.6 Pre-bias Start-up 20

12.7 Internal Low – Dropout (LDO) Regulator 21

12.8 Over Current Protection (OCP) 21

12.9 Under Voltage Protection (UVP) 22

12.10 Over Voltage Protection (OVP)..... 22

12.11 Over Temperature Protection (OTP) 23

12.12 Power Good (PGood) Output 23

12.13 Minimum ON – Time and Minimum OFF – Time..... 24

12.14 Selection of Feedforward Capacitor and Feedback Resistors..... 24

13 Design example.....26

13.1 Enabling the IR3846A 26

13.2 Selecting Input Capacitors..... 26

13.3 Inductor Selection..... 27

13.4 Output Capacitor Selection 27

13.5 Output Voltage Programming..... 28

13.6 Feedforward Capacitor 28

13.7 Bootstrap Capacitor 28

13.8 V_{IN} and V_{CC}/LDO bypass Capacitor 28

Table of contents

14	Application Information.....	29
14.1	Application Diagram.....	29
14.2	Typical Operating Waveforms.....	30
15	Layout Recommendations.....	34
15.1	Solder Mask	34
15.2	Stencil Design	36
16	Package	37
16.1	Dimensions	37
17	Environmental Qualifications	38
	Revision history.....	39

Ordering information

1 Ordering information

1. Ordering Information

Base Part Number	Package Type	Standard Pack Form and Qty		Orderable Part Number
IR3846AMTRPBF	PQFN 5 mm x 7 mm	Tape and Reel	4000	IR3846AMTRPBFAUMA1

IR3846AMTRPBF

Packing type	Tape & Reel
Moisture protection packing	Dry
Packing size	330 mm

Halogen Free	Yes
RoHS compliant	Yes
Total lead free	No

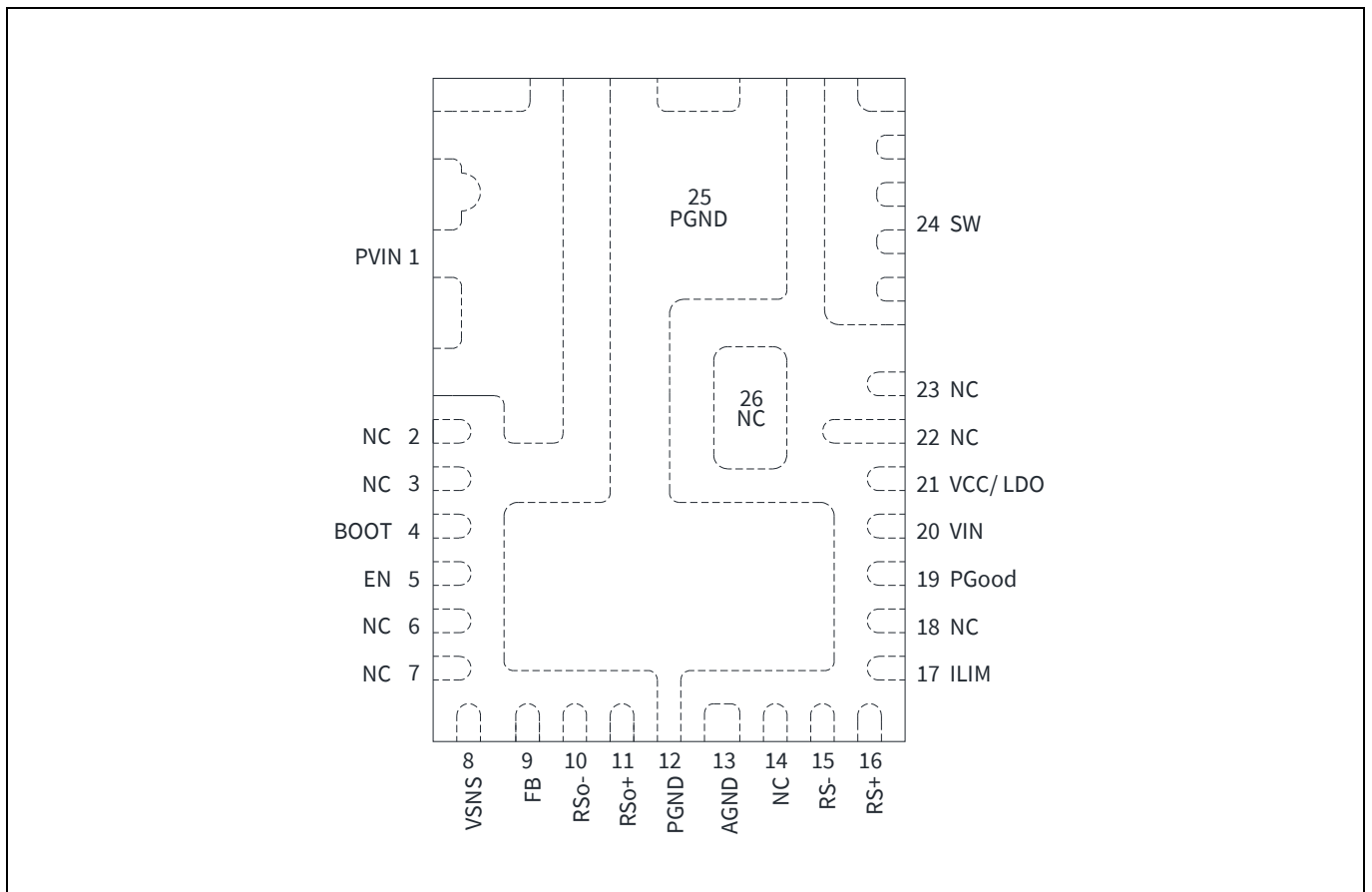

Figure 1 Package Top View

2 Functional block diagram

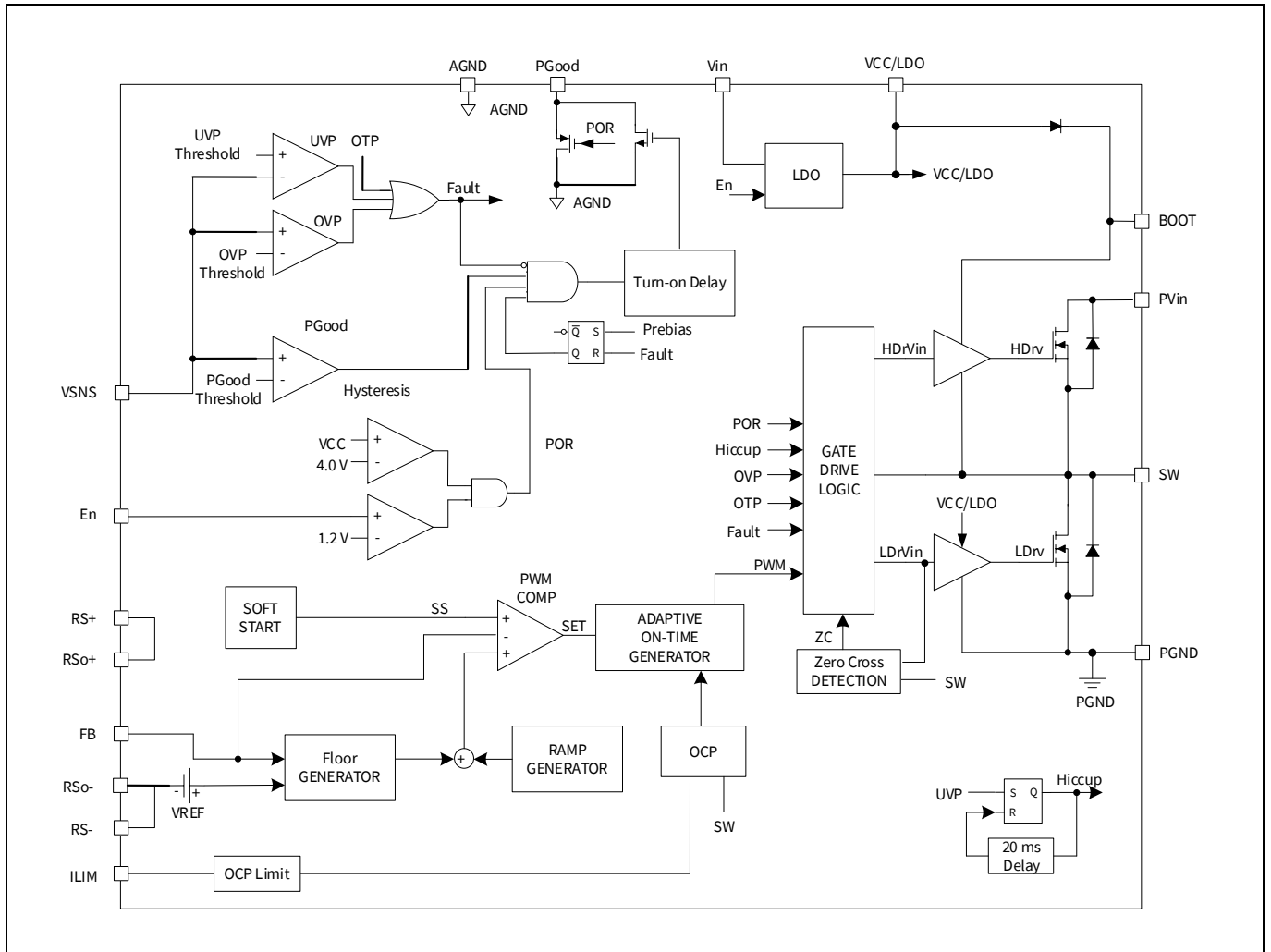

Figure 2 Block diagram

3 Typical application diagram

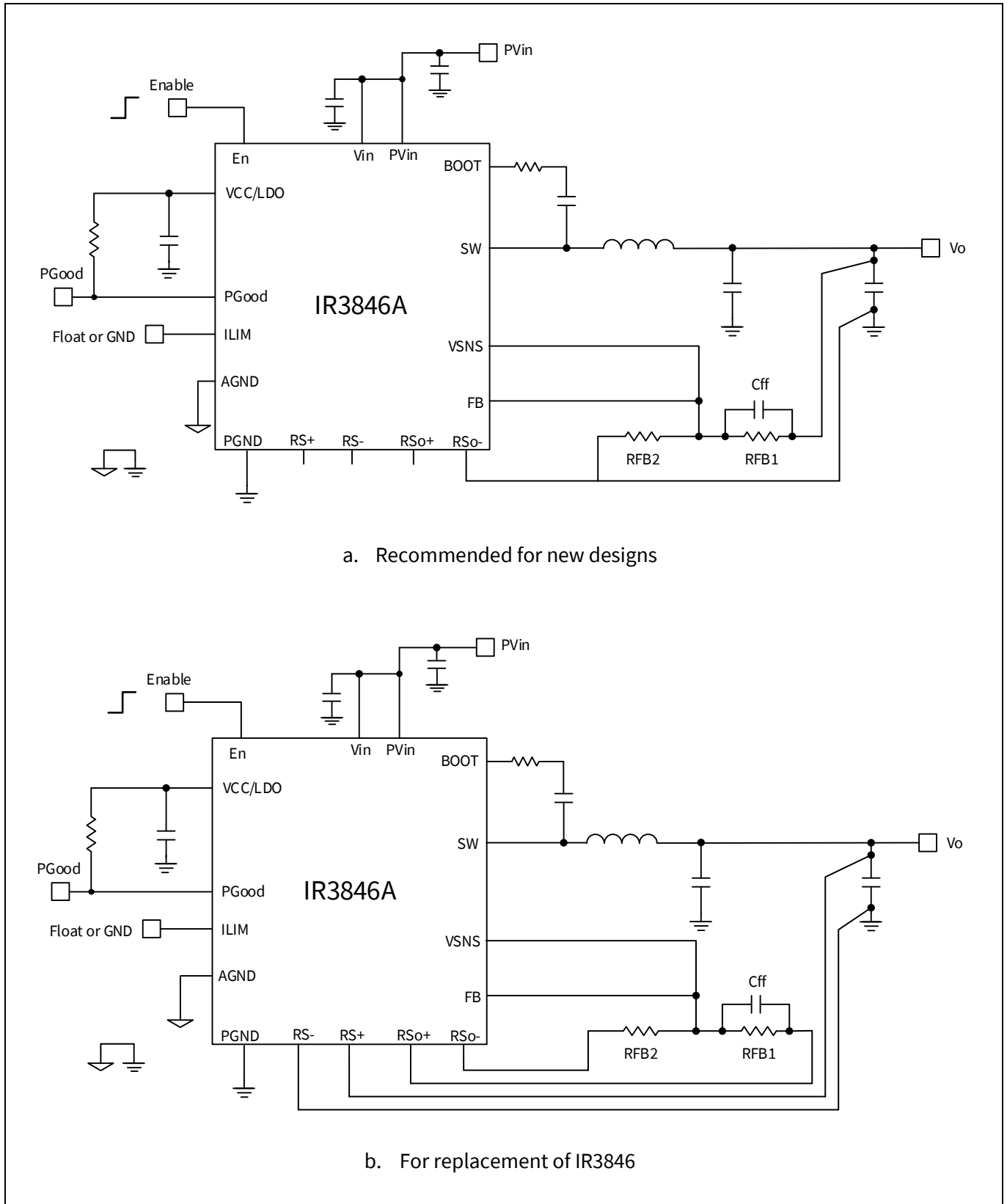

Figure 3 IR3846A basic application circuit

Pin descriptions

4 Pin descriptions

Note: I = Input, O = Output

Pin#	Pin Name	I/O	Type	Pin Description
1	PVIN	I	Power	Input voltage for power stage. Bypass capacitors between PVIN and PGND should be connected very close to this pin and PGND; also forms input to feedforward block.
2, 3, 6, 7, 14, 18, 22, 23, 26	NC	-	No connect	This pin should be left floating. Note: Pins 6 and 18 are internally connected to PGND and must be left floating or connected to PGND. Pins 23 and 26 are internally connected and must be left floating.
4	BOOT	I	Analog	Supply voltage for the high side driver. Connect this pin to the SW pin through a bootstrap circuit.
5	EN	I	Analog	Enable pin to turn the IC on and off.
8	VSNS	I	Analog	Sense pin for over voltage protection, under voltage protection and PGood. Tie this pin to Vout using a resistor divider. Alternatively, tie this pin to FB pin directly.
9	FB	I	Analog	Output voltage feedback pin. Connect this pin to the output of the regulator via a resistor divider to set the output voltage.
10	RS-	I	Analog	Internally connected to 'RS-' pin and used as ground for internal reference voltage. The feedback resistor divider should be connected to this pin when using pseudo remote voltage sensing. It should always be connected to an external GND.
11	RS+	I/O	Analog	Internally connected to 'RS+' pin. Provides the output voltage connection to the feedback resistor divider when using pseudo remote sense.
12, 25	PGND	-	Ground	Power ground. This pin should be connected to the system's power ground plane. Bypass capacitors between PVIN and PGND should be connected very close to PVIN pin and this pin.
13	AGND	-	Ground	Signal ground for the internal circuitry except for the internal reference voltage.
15	RS-	I	Analog	This pin provides the return connection for a pseudo remote voltage sensing. Connect to ground at the load.
16	RS+	I	Analog	This pin provides output voltage feedback. Connect to output at the load.
17	ILIM	I	Analog	Shorting to GND or floating the pin sets the Over Current Protection (OCP) limit. Two user selectable OCP limits are available.
19	PGood	O	Analog	Power Good status output pin is open drain. Connect a pull up resistor from this pin to VCC/LDO or to an external bias voltage, e.g. 3.3 V.
20	VIN	I	Power	Input voltage for the Internal LDO. A 4.7 μF capacitor should be connected between this pin and PGND. If an external supply is connected to VCC/LDO pin, VIN should be

Pin descriptions

Pin#	Pin Name	I/O	Type	Pin Description
				shorted to the VCC/LDO pin and a 10 μ F ceramic capacitor can be shared between VIN and VCC/LDO to PGND.
21	VCC/LDO	I/O	Power	Input bias for an external VCC voltage or output of the internal LDO. A ceramic capacitor valued between 2.2 μ F and 10 μ F is recommended for use between VCC/LDO and the Power ground (PGND).
24	SW	O	Power	Switch node. This pin is connected to the output inductor.

Absolute maximum ratings

5 Absolute maximum ratings

Absolute maximum ratings

Description	Min	Max	Unit	Conditions
PVIN, VIN, EN to PGND	-0.3	25	V	Note 1
PVIN to SW	-0.3 (dc), -5 for 5 ns	25	V	
VCC/LDO to PGND	-0.3	6	V	Note 1
BOOT to PGND	-0.3	29	V	Note 1
SW to PGND	-0.3 (dc), -5 for 5 ns	25	V	Note 1
BOOT to SW	-0.3	6	V	
ILIM, FB, PGood, VSNS, RS+, RSo+ to AGND	-0.3	6	V	Note 1
PGND, RS-, RSo- to AGND	-0.3	0.3	V	
Storage Temperature Range	-55	150	°C	
Junction Temperature Range	-40	150	°C	

Note:

1. PGND, RSo-, RS-, and AGND pin are connected together

Attention: Stresses beyond these listed under “Absolute Maximum Ratings” may cause permanent damage to the device. These are stress ratings only and functional operation of the device at these or any other conditions beyond those indicated in the operational sections of the specifications are not implied.

Thermal Characteristics

6 Thermal Characteristics

6.1 Thermal Characteristics

Description	Symbol	Values	Test Conditions
Junction to Ambient Thermal Resistance	θ_{JA}	14.3 °C/W	Note 2
Junction to PCB Thermal Resistance	θ_{JC-PCB}	2.71 °C/W	
Junction to Case Top Thermal Resistance	θ_{JC}	30 °C/W	

Note:

2. Thermal resistance (θ_{JA}) is measured with components mounted on a highly effective thermal conductivity test board.

7 Electrical specifications

7.1 Recommended operating conditions

Description	Min	Max	Unit	Note
PVIN Voltage Range with External VCC	2	17	V	Note 3, Note 4
PVIN Voltage Range with Internal LDO	4.5	17	V	Note 4, Note 5
VCC Supply Voltage Range	4.3	5.5	V	Note 3, Note 6
Typical Output Voltage Range	0.6	6	V	Note 7 & 8
Continuous Output Current Range		40	A	Note 8
Operating Junction Temperature	-40	125	°C	

Note:

3. V_{IN} is shorted to VCC/LDO and uses an external bias voltage.
4. A common practice is to have 20% margin on the maximum SW node voltage in the design. A small resistor in series with the BOOT pin might be needed to ensure the maximum SW node spike voltage does not exceed 20 V. Alternatively, a snubber can be used at the SW node to reduce the SW node spike.
5. V_{IN} is connected to PVIN and the internal LDO is used. For single-rail applications with the internal LDO, and $PVIN = V_{IN} = 4.3\text{ V} - 5.4\text{ V}$, the internal LDO may enter dropout mode. OCP limits can be reduced due to the lower VCC voltage. Please refer to [Section 12.7](#) for more detailed design guidelines.
6. The IR3846A is designed to function with VCC as low as 4.3 V. However, electrical specifications such as OCP limits may be degraded.
7. The maximum output voltage is limited by the minimum off-time. Please refer to [Section 12.13](#) for details. Also note that OCP limit may be degraded when off-time is close to the minimum off-time.
8. Maximum output current capability can be reduced at elevated ambient temperatures. Lower VCC voltage can result in higher $R_{DS(ON)}$ and therefore require more thermal derating.

Electrical specifications
7.2 Electrical characteristics

Note: Unless otherwise specified, the specifications apply over $4.5\text{ V} \leq V_{IN} = P_{VIN} \leq 17\text{ V}$, $0\text{ }^\circ\text{C} < T_J < 125\text{ }^\circ\text{C}$. Typical values are specified at $T_a = 25\text{ }^\circ\text{C}$.

Parameter	Symbol	Conditions	Min	Typ	Max	Unit
Power Stage						
Top Switch	$R_{DS(on)_{Top}}$	$T_J = 25\text{ }^\circ\text{C}$		3.31		m Ω
Bottom Switch	$R_{DS(on)_{Bot}}$	$T_J = 25\text{ }^\circ\text{C}$		0.75		
Bootstrap Forward Voltage		$I(\text{BOOT}) = 25\text{ mA}$		370	600	mV
SW float voltage	V_{SW}	EN = 0 V			300	mV
		EN = high, No Switching			300	
Dead Band Time	T_{DB}	SW node rising edge, Note 9		10		ns
		SW node falling edge, Note 9		10		ns
Supply Current						
VIN Supply Current (standby)	$I_{in(Standby)}$	EN = Low, No Switching		4	10	μA
VIN Supply Current (static)	$I_{in(Static)}$	EN = 2 V, No Switching		2.3	4	mA
Soft Start						
Soft Start time	SS time		0.75	1	1.5	ms
Feedback Voltage						
Feedback Voltage	VFB			0.6		V
Accuracy		$0\text{ }^\circ\text{C} < T_J < 85\text{ }^\circ\text{C}$	-0.5		+0.5	%
		$-40\text{ }^\circ\text{C} < T_J < 125\text{ }^\circ\text{C}$, Note 10	-1		1	
VFB Input Current	IVFB	VFB = 0.6 V, $T_J = 25\text{ }^\circ\text{C}$	-0.15	0	+0.15	μA
On-Time Timer Control						
On Time	Ton	$V_{IN} = 12\text{ V}$, $V_o = 1\text{ V}$, Note 11		147		ns
Minimum On-Time	Ton (min)	$V_{IN} = 12\text{ V}$, $V_o = 0\text{ V}$		23	32	ns
Minimum Off-Time	Toff (min)	$T_J = 25\text{ }^\circ\text{C}$, VFB = 0 V		270	360	ns
VCC LDO Output						
Output Voltage	VCC	$5.5\text{ V} \leq V_{IN} \leq 17\text{ V}$, when $I_{cc} = 50\text{ mA}$, Cl _{oad} = 2.2 μF	4.7	5.0	5.3	V
VCC Dropout	VCC_drop	$V_{IN} = 4.3\text{ V}$, $I_{cc} = 50\text{ mA}$, Cl _{oad} = 2.2 μF			300	mV
Short Circuit Current	Ishort	$5.5\text{ V} \leq V_{IN} \leq 17\text{ V}$		90		mA
Under Voltage Lockout						
VCC-Start Threshold	VCC_UVLO_Start	VCC Rising Trip Level	3.8	4.0	4.2	V
VCC-Stop Threshold	VCC_UVLO_Stop	VCC Falling Trip Level	3.6	3.8	4.0	
Enable-Start-Threshold	EN_UVLO_Start	ramping up	1.14	1.2	1.36	V
Enable-Stop-Threshold	EN_UVLO_Stop	ramping down	0.9	1	1.06	
Input Impedance	REN		500	1000	1500	k Ω

Electrical specifications

Parameter	Symbol	Conditions	Min	Typ	Max	Unit
Over Current Limit						
Current Limit Threshold (Valley Current)	I _{oc}	T _j = 25 °C, VCC = 5.0 V, ILIM = Floating	44	53.5	61	A
		T _j = 25 °C, VCC = 5.0 V, ILIM = GND	32	39	45	
Over Voltage Protection						
OVP Trip Threshold	OVP_Vth	VSNS Rising	115	121	125	% Vref
		VSNS Falling, OVP hysteresis	110	115	120	
OVP Protection Delay	OVP_Tdly			4		μs
Under Voltage Protection						
UVP Trip Threshold	UVP_Vth	VSNS Falling	65	70	75	% Vref
UVP Protection Delay	UVP_Tdly			2		μs
Hiccup Blanking Time	Tblk_Hiccup			20		ms
Power Good						
PGood Turn on Threshold	VPG (upper)	VSNS Rising	85	91	95	% Vref
PGood Turn off Threshold	VPG (lower)	VSNS Falling	80	84	90	% Vref
PGood Sink Current	IPG	PGood = 0.5 V, EN = 2 V	2.5	5		mA
PGood Voltage Low	VPG (low)	VIN = VCC = 0 V, Rpull-up = 50 kΩ to 3.3 V		0.3	0.5	V
PGood Turn on Delay	VPG (on)_Dly	VSNS Rising, see VPG (upper)		2.5		ms
PGood Comparator Delay	VPG (comp)_Dly	VSNS < VPG (lower) or VSNS > VPG (upper)	1	2	3.5	μs
PGood Open Drain Leakage Current		PGood = 3.3 V			1	μA
Thermal Shutdown						
Thermal Shutdown		Note 9		140		°C
Hysteresis		Note 9		20		

Note:

9. Guaranteed by construction and not tested in production.
10. Cold temperature performance is guaranteed via correlation using statistical quality control. Not tested in production.
11. Ton is trimmed so that the target switching frequency is achieved at around 16 A load current.

Typical efficiency and power loss curves

8 Typical efficiency and power loss curves

8.1 $P_{VIN} = V_{IN} = 12\text{ V}$, $F_{sw} = 600\text{ kHz}$, Mode: FCCM

$P_{VIN} = V_{IN} = 12\text{ V}$, $V_{CC} = \text{Internal LDO}$, $I_o = 0\text{ A} - 40\text{ A}$, $F_{sw} = 600\text{ kHz}$, Room Temperature, No Air Flow. Note that the efficiency and power loss curves include losses of the IR3846A, inductor losses, losses of the input and output capacitors, and PCB trace losses. The table below shows the inductors used for each of the output voltages in the efficiency measurement.

Table 1 Inductors for $P_{VIN} = V_{IN} = 12\text{ V}$, $F_{sw} = 600\text{ kHz}$

Vout (V)	Lout (nH)	P/N	DCR (mΩ)	Size (mm)
1.0	150 nH	CMLB104T-R15MS	0.55	11.15 x 10.0 x 3.8
1.2	150 nH	CMLB104T-R15MS	0.55	11.15 x 10.0 x 3.8
1.8	220 nH	CMLB104T-R22MS	0.93	11.15 x 10.0 x 3.8
3.3	360 nH	CMLB104T-R36MS	1.18	11.15 x 10.0 x 3.8
5.0	360 nH	CMLB104T-R36MS	1.18	11.15 x 10.0 x 3.8

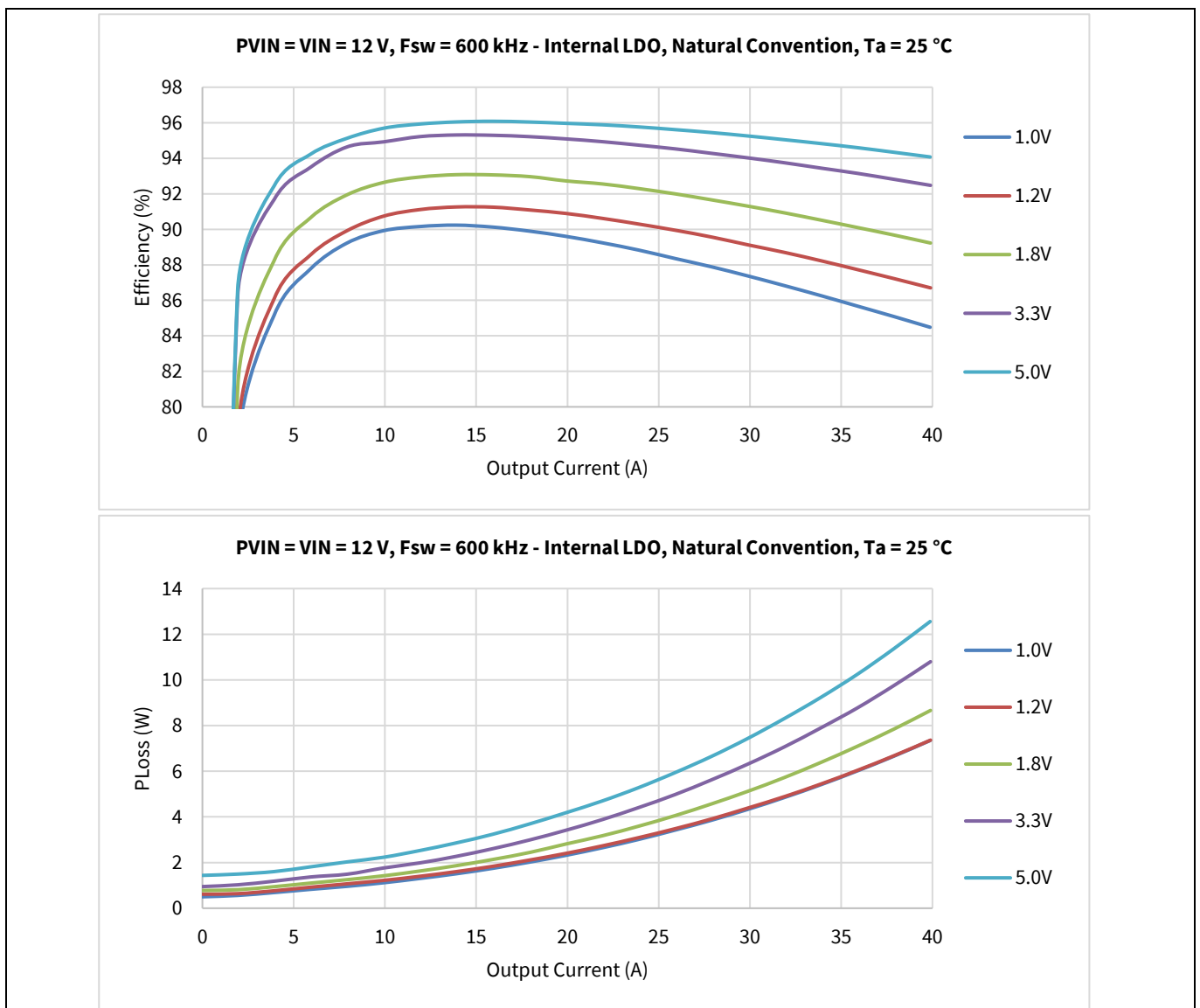

Thermal de-rating curves

9 Thermal de-rating curves

Measurement is done on IR3846A evaluation board. The PCB is an 8-layer board with 1.8-ounce copper for top and bottom layers and 2-ounce copper for the inner layers, FR4 material, size 3.55”x3.5”.

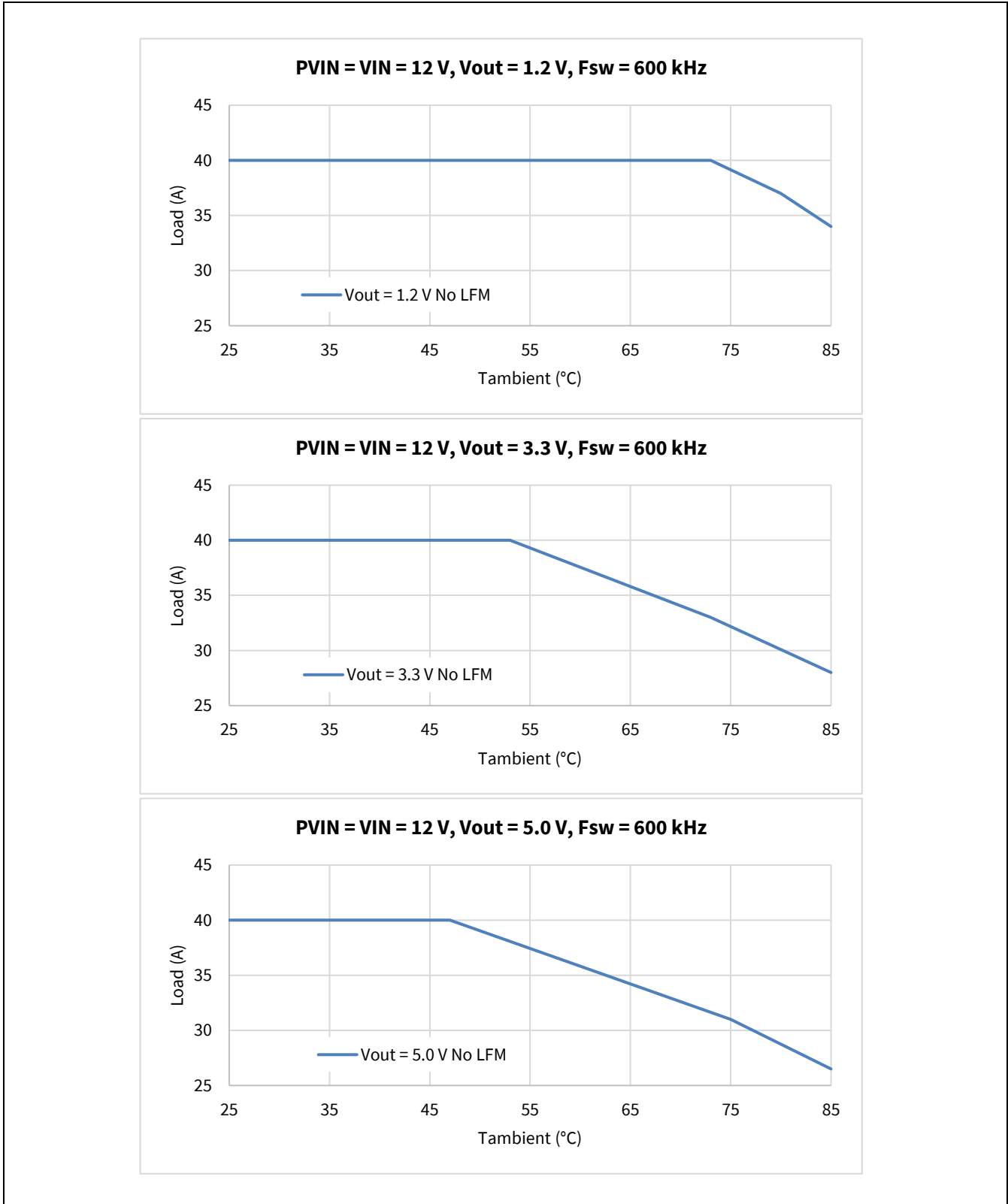

Figure 4 Thermal derating curves, PVIN = 12 V, Vout = 1.0 V/3.3 V/5 V, fsw = 600 kHz, VCC = Internal LDO

10 R_{DS(ON)} of MOSFET over temperature

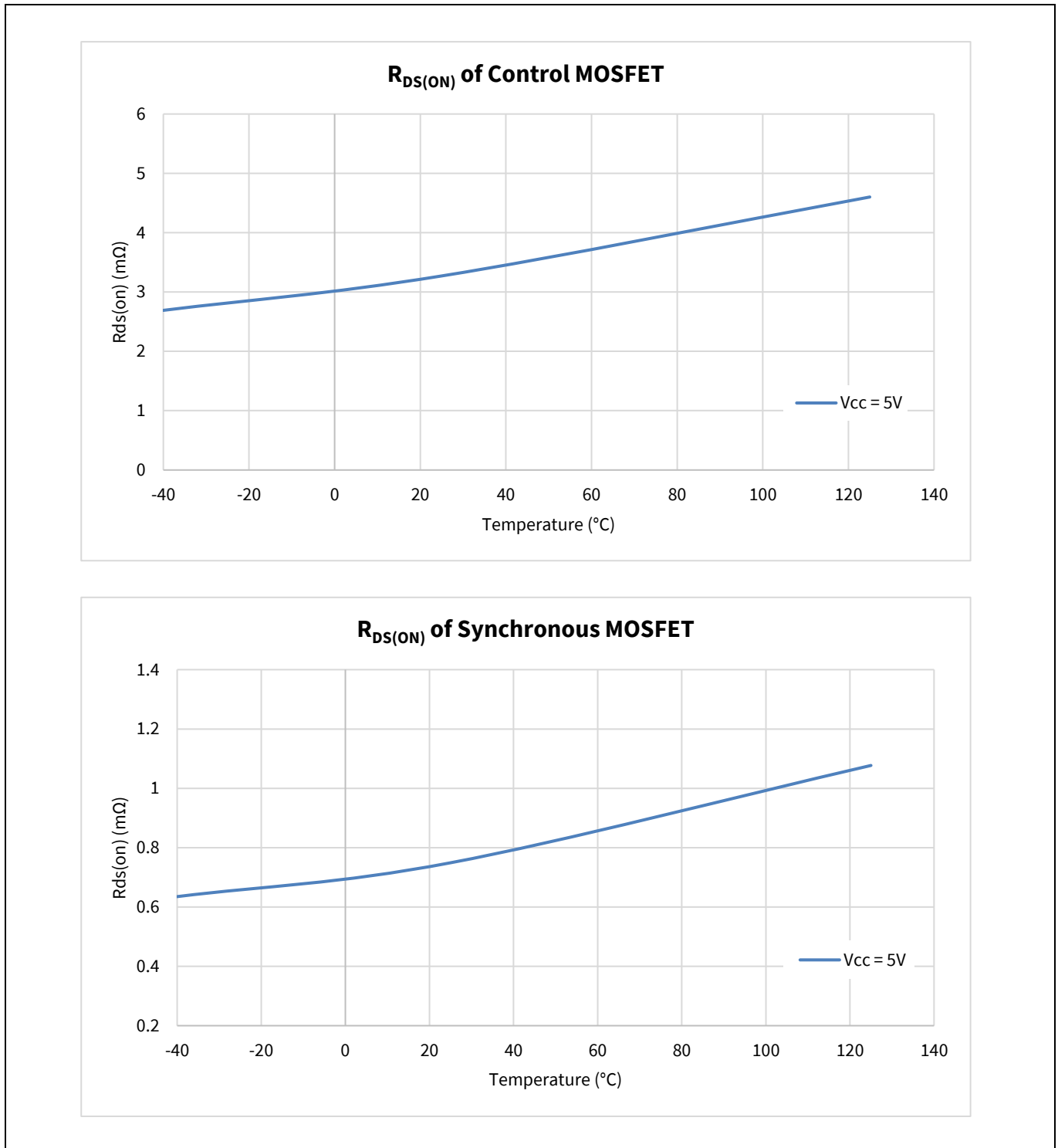

Figure 5 R_{DS(ON)} of MOSFETs over Junction Temperature

Typical operating characteristics (-40 °C ≤ T_j ≤ +125 °C)

11 Typical operating characteristics (-40 °C ≤ T_j ≤ +125 °C)

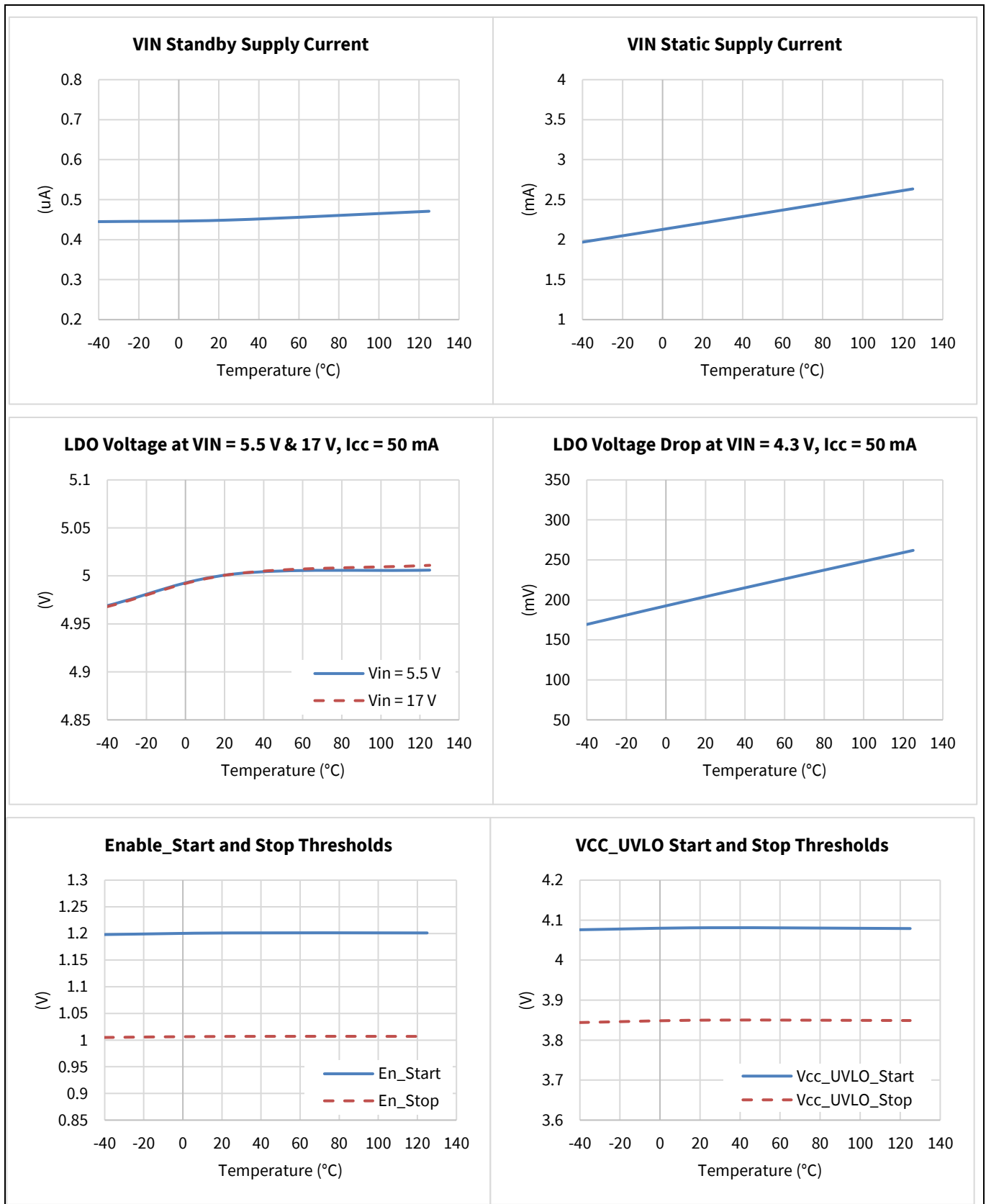

Figure 6 Typical operating characteristics (set 1 of 2)

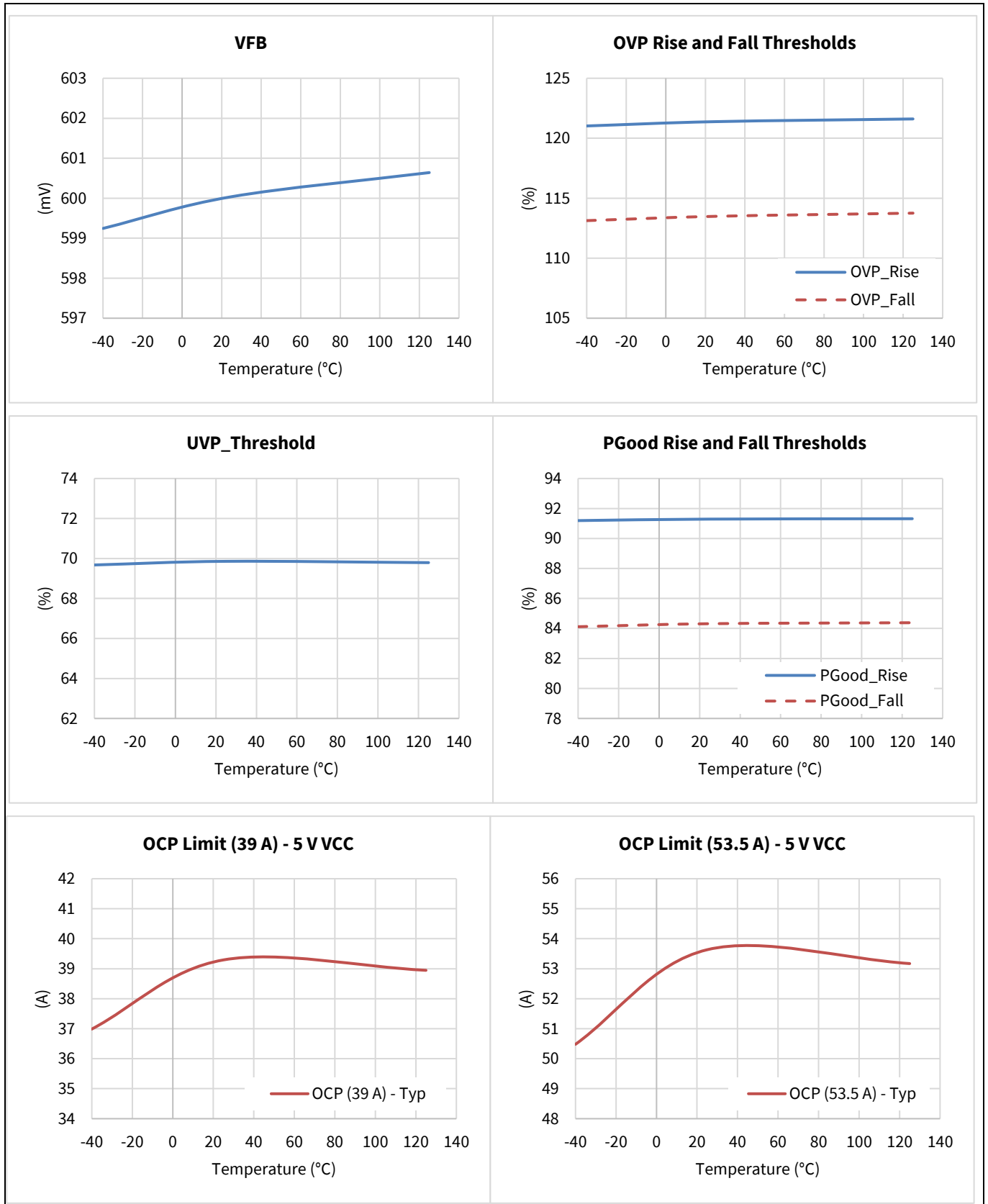

Figure 7 Typical operating characteristics (set 2 of 2)

12 Theory of operation

12.1 Fast Constant On-Time Control

The IR3846A features a proprietary fast Constant On-Time (COT) Control, which can provide fast load transient response, good output regulation and minimize design effort. Fast COT control compares the output voltage, V_o , to a floor voltage combined with an internal ramp signal. When V_{out} drops below that signal, a PWM signal is initiated to turn on the high-side FET for a fixed on-time. The floor voltage is generated from an internally-compensated error amplifier, which compares V_{out} with a reference voltage. Compared to the traditional COT control, Fast COT control significantly improves V_{out} regulation.

12.2 Enable

The EN pin controls the on/off state of the IR3846A. An internal Under Voltage Lock-Out (UVLO) circuit monitors the EN voltage. When the EN voltage is above an internal threshold, the internal LDO starts to ramp up. When the VCC/LDO voltage rises above the VCC_UVLO_Start threshold, the soft-start sequence starts. The EN pin can be configured in three ways, as shown in **Figure 8**. With configuration 2, the Enable signal is derived from the PVIN voltage by a resistor divider, R_{EN1} and R_{EN2} . By selecting different divider ratios, users can program a UVLO threshold for the bus voltage. This is a very desirable feature because it prevents the IR3846A from operating until PVIN is higher than a desired voltage level. For some space-constrained designs, the EN pin can be directly connected to PVIN without using the external resistor divider, as shown in Configuration 3. The EN pin should not be left floating. A pull-down resistor in the range of tens of kilohms is recommended. **Figure 9** illustrates the corresponding start-up sequences with three EN configurations.

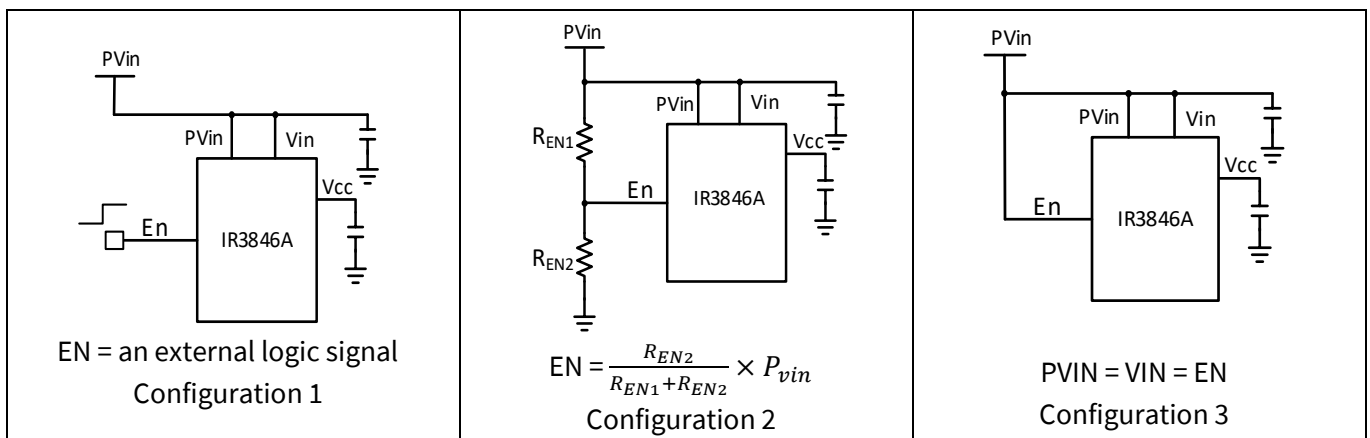

Figure 8 Enable Configurations

Theory of operation

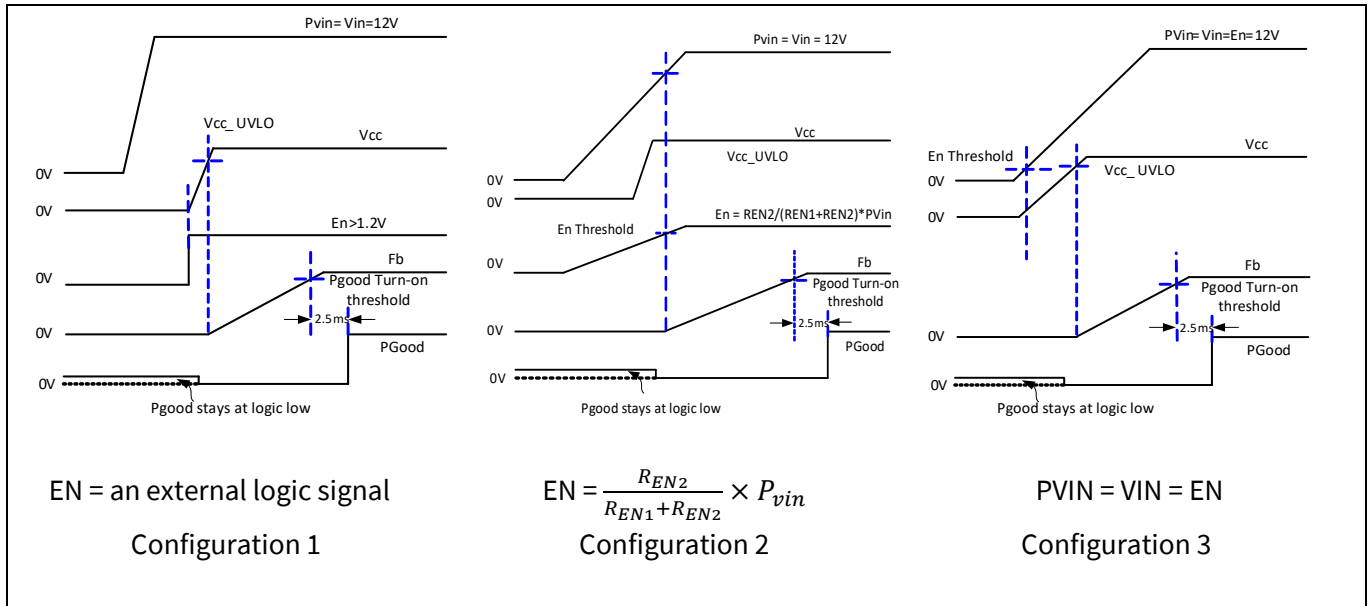

Figure 9 Start-up sequence

12.3 FCCM Operation

The IR3846A offers a single mode of operation: Forced Continuous Conduction (FCCM). With FCCM, the IR3846A always operates as a synchronous buck converter with a pseudo-constant switching frequency leading to small output voltage ripple.

12.4 Pseudo-Constant Switching Frequency

The IR3846A offers a switching frequency (F_{sw}) of 600 kHz. The corresponding on-time of the Control FET for a given PVIN and V_o , as shown by the formula below.

$$T_{on} = \frac{V_o}{PV_{in}} \times \frac{1}{F_{sw}}$$

Where F_{sw} is the switching frequency. During operation, the IR3846A monitors PVIN and V_o , and can automatically adjust the on-time to maintain the F_{sw} . As load current increases, the switching frequency can increase to compensate for power losses.

12.5 Soft-start

The IR3846A has an internal digital soft-start to control the output voltage rise and to limit the current surge at start-up. To ensure a correct start-up, the soft-start sequence initiates when the EN and VCC voltages rise above their respective thresholds. The internal soft-start signal linearly rises from 0 V to 0.6 V in a defined time duration. The soft-start time does not change with the output voltage. During soft-start, the IR3846A operates in DEM until 1 ms after the output voltage ramps above the PGood turn-on threshold. The IR3846A has a fixed soft-start time of 1 ms.

12.6 Pre-bias Start-up

The IR3846A is able to start up into a pre-charged output without causing oscillations and disturbances of the output voltage. When the IR3846A starts up with a pre-biased output voltage, both control FET and Sync FET are kept off until the internal soft-start signal exceeds the FB voltage.

Theory of operation

12.7 Internal Low – Dropout (LDO) Regulator

The IR3846A has an integrated low-dropout LDO regulator, providing the bias voltage for the internal circuitry. To minimize standby current, the internal LDO is disabled when the EN voltage is pulled low. VIN pin is the input of the LDO. When using the internal LDO for a single rail operation, VIN pin should be connected to the PVIN pin. To save power losses on the LDO, an external bias voltage can be used by connecting VIN pin to the VCC/LDO pin. **Figure 10** illustrates the configuration of VCC/LDO, and VIN pin.

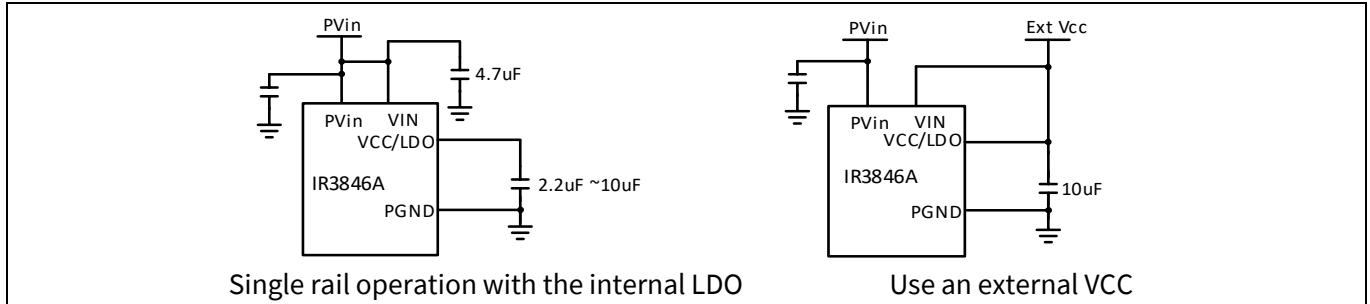

Figure 10 Configuration of Using the internal LDO or an external VCC.

Section 7.1 specified the recommended operating voltage range of VIN and VCC under different configurations. The following design guidelines are recommended when configuring the VCC/LDO.

- Place a bypass capacitor to minimize the disturbance on the VCC pin. For single rail operation using the internal LDO, a 4.7 µF low ESR ceramic capacitor must be used between VIN pin and PGND and a 2.2 µF~10 µF low ESR ceramic capacitor is required to be placed close to the VCC/LDO with reference to PGND. 10 µF MLCC is recommended for the VCC bypass capacitor when VIN is below 5.5 V. When using an external VCC bias voltage, a 10 µF ceramic capacitor can be shared by VIN and VCC/LDO pin.
- For applications using the internal LDO with $4.3\text{ V} \leq \text{VIN} \leq 5.4\text{ V}$, the LDO can be in the dropout mode. It is important to ensure that the LDO voltage does not fall below the VCC UVLO threshold voltage. At $\text{VIN} = 4.3\text{ V}$, I_{CC} must not exceed 50 mA under all operating conditions such as during a step-up load transient, in which the control loop may require the increase of F_{sw} . OCP limits can also be reduced due to the lower VCC voltage.

12.8 Over Current Protection (OCP)

The IR3846A offers cycle-by-cycle OCP response with two selectable current limits set by floating or shorting the ILIM pin to GND. The selected OCP limit is loaded to the IC during power up and cannot be changed on the fly. To change the OCP limit, users must cycle the EN signal or VCC voltage. Cycle-by-cycle OCP response allows the IR3846A to fulfill a brief high current demand, such as a high inrush current during start-up. Detailed operation is explained as follows:

OCP is activated when EN voltage is above its threshold. The OCP circuitry monitors the current of the Synchronous MOSFET through its $R_{\text{DS(ON)}}$. When a new PWM pulse is requested by the control loop, if the current of the Synchronous MOSFET exceeds the OCP limit, the IR3846A skips the PWM pulse and extends the on-time of the Synchronous MOSFET until the current drops below the OCP limit. OCP operation is also illustrated in **Figure 11**. During OCP events, the valley of the inductor current is regulated around the OCP limit. However, during the first switching cycle when the OCP is tripped, the valley of the inductor current can drop slightly below the OCP limit. It should be noted that OCP events do not pull the PGood signal low unless the V_o drops below the PGood turn-off threshold. If the OCP event persists, the output voltage can eventually drop below the Under Voltage Protection (UVP) threshold and trigger UVP. Then the IR3846A enters hiccup mode.

The OCP limits are thermally compensated. The OCP limits specified in Section 7.2 refer to the valley of the inductor current when OCP is tripped. Therefore, the corresponding output DC current can be calculated as follows:

Theory of operation

$$I_{out_OCP} = I_{LIM} + \frac{\Delta i_L}{2}$$

Where: I_{out_OCP} = Output DC current when OCP is tripped. I_{LIM} = OCP limit specified in the Section 7.2, which is the valley of inductor current. Δi_L = Peak-peak inductor ripple current.

To avoid inductor saturation during OCP events, the following criterion is recommended for the inductor saturation current rating.

$$I_{sat} \geq I_{LIM_max} + \Delta i_L$$

Where: I_{sat} is the inductor saturation current and I_{LIM_max} is the maximum spec of the OCP limit.

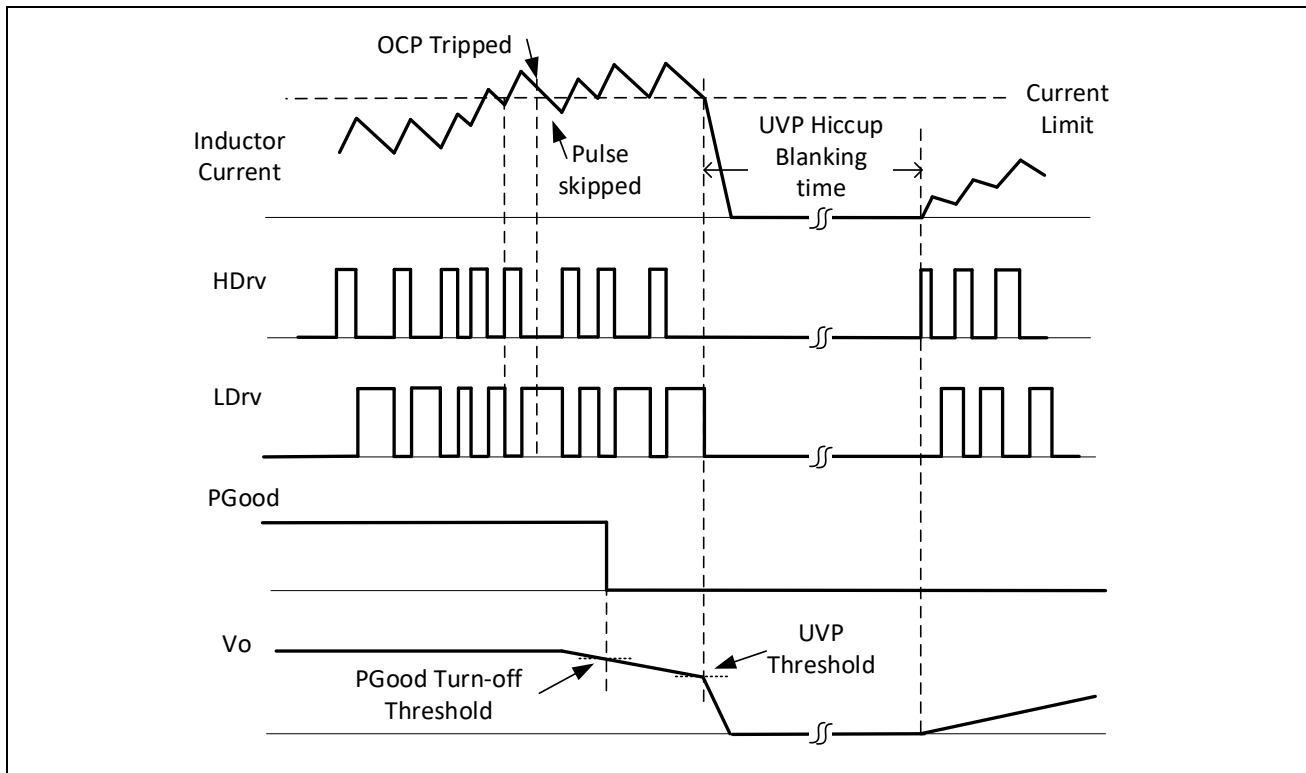

Figure 11 Cycle-by-cycle OCP response

12.9 Under Voltage Protection (UVP)

Under Voltage Protection (UVP) provides additional protection during OCP fault or other faults. UVP protection is enabled when the soft-start voltage rises above 100 mV. UVP circuitry monitors VSNS voltage. When VSNS is below the UVP threshold for 2 μs (typical), an under voltage trip signal asserts and both Control MOSFET and Synchronous MOSFET are turned off. The IR3846A enters hiccup mode with a blanking time of 20 ms, during which Control MOSFET and Synchronous MOSFET remain off. After the completion of blanking time, the IR3846A attempts to recover to the nominal output voltage with a soft-start, as shown in Figure 11. The IR3846A will repeat hiccup mode and attempt to recover until the UVP condition is removed.

12.10 Over Voltage Protection (OVP)

Over Voltage Protection (OVP) is achieved by comparing the VSNS voltage to an OVP threshold voltage. When the VSNS voltage exceeds the OVP threshold, an over voltage trip signal asserts after 4 μs (typical) delay. The Control MOSFET is latched off immediately and PGood flags low. The Synchronous MOSFET remains on to discharge the output capacitor. When VSNS voltage drops below around 115% of the reference voltage, Synchronous MOSFET turns off to prevent complete depletion of the output capacitors. Figure 12 illustrates the OVP operation. The OVP comparator becomes active when the EN signal is above the start threshold.

Theory of operation

IR3846A has a Latched OVP response, i.e., when OVP is triggered, the Control FET remains latched off until either VCC voltage or EN signal is cycled.

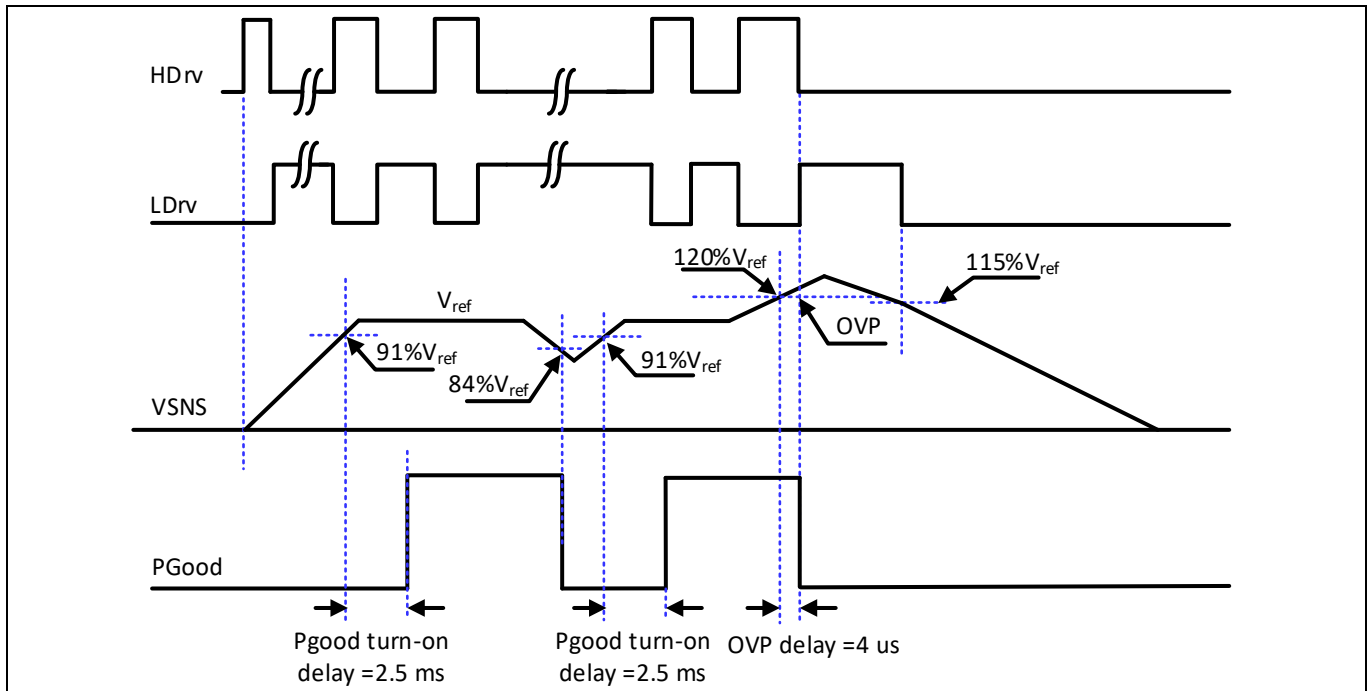

Figure 12 Over voltage protection response and PGood behavior.

12.11 Over Temperature Protection (OTP)

Temperature of the controller is monitored internally. When the temperature exceeds the over temperature threshold, OTP circuitry turns off both Control and Synchronous MOSFETs and resets the internal soft start. Automatic restart is initiated when the sensed temperature drops back into the operating range. The thermal shutdown threshold has a hysteresis of 20 °C.

12.12 Power Good (PGood) Output

The PGood pin is the open drain of an internal NFET, and must be externally pulled high through a pull-up resistor. The PGood signal is high when three criteria are satisfied:

1. EN signal and VCC voltage are above their respective thresholds.
2. No over voltage or over temperature faults occur.
3. V_o is within regulation.

In order to detect if V_o is in regulation, the PGood comparator continuously monitors VSNS voltage. When VSNS voltage ramps up above the upper threshold, the PGood signal is pulled high after 2.5 ms. When VSNS voltage drops below the lower threshold, the PGood signal is pulled low immediately. **Figure 12** illustrates the PGood response.

During start-up with a pre-biased output voltage, the PGood signal is held low before the first PWM is generated and is then pulled high with 2.5 ms delay after VSNS voltage rises above the PGood threshold. IR3846A also integrates an additional PFET in parallel to the PGood NFET, as shown in **Figure 2**. This PFET allows the PGood signal to stay at logic low when the VCC voltage is not present and the PGood pin is pulled up by an external bias voltage. Please refer to **Figure 9**. Since the PGood PFET has relatively higher on resistance, a 50 kΩ pull-up resistor is needed for a PGood bias voltage of 3.3 V to maintain the PGood signal at logic low when PGood PFET is on.

Theory of operation

12.13 Minimum ON – Time and Minimum OFF – Time

The minimum on-time refers to the shortest time for the Control MOSFET to be reliably turned on. The minimum off-time refers to the minimum time duration in which the Synchronous FET stays on before a new PWM pulse is generated. The minimum off-time is needed for IR3846A to charge the bootstrap capacitor, and to sense the current of the Synchronous MOSFET for OCP.

For applications requiring a small duty cycle, it is important that the switching frequency results in an on-time larger than the maximum spec of the minimum on-time in Section 7.2. Otherwise, the resulting switching frequency may be lower than the desired target. The following formula should be used to check for the minimum on-time requirement.

$$\frac{V_0}{kf_{sw} \times V_{in}} > \max \text{ spec of } T_{on(\min)}$$

Where f_{sw} is the switching frequency. K is the variation of the switching frequency. As a rule of thumb, select $k = 1.25$ to ensure design margin.

For applications requiring a high duty cycle, it is important to make sure the resulting off-time is longer than the maximum spec of the minimum off-time in Section 7.2, which can be calculated as shown below.

$$\frac{V_{in} - V_0}{kf_{sw} \times V_{in}} > \max \text{ spec of } T_{off(\min)}$$

Where f_{sw} is the switching frequency. K is the variation of the switching frequency. As a rule of thumb, select $k = 1.25$ to ensure design margin.

The resulting maximum duty cycle is therefore determined by the selected on-time and minimum off-time.

$$D_{max} = \frac{T_{on}}{T_{on} + T_{off(\min)}}$$

12.14 Selection of Feedforward Capacitor and Feedback Resistors

Output voltage can be programmed with an external voltage divider. The FB voltage is compared to an internal reference voltage of 0.6 V. The divider ratio is set to provide 0.6 V at the FB pin when the output is at its desired value. The calculation of the feedback resistor divider is shown below.

$$V_O = V_{ref} \times \left(1 + \frac{R_{FB1}}{R_{FB2}}\right)$$

Where R_{FB1} and R_{FB2} are the top and bottom feedback resistors.

A small MLCC capacitor, C_{ff} , is preferred in parallel with the top feedback resistor, R_{FB1} , to provide extra phase boost and improve the transient load response, as shown in Figure 13. Following formula can be used to help select C_{ff} and R_{FB1} . The value of C_{ff} is recommended to be 100 pF or higher to minimize the impact of circuit parasitic capacitance, where L_O and C_O are the output LC filter of the buck regulator. C_{ff} and R_{FB1} may be further optimized based on the transient load tests.

$$R_{FB1}C_{ff} = \frac{\sqrt{L_O C_O}}{m \times 4.9}$$

Theory of operation

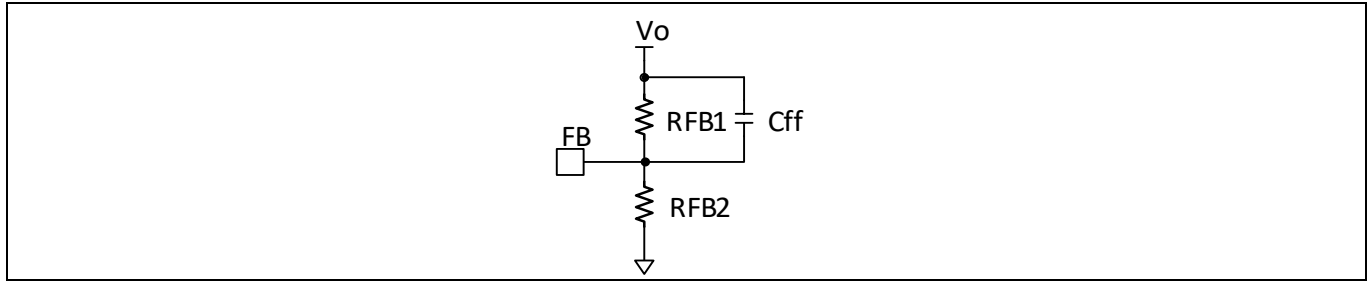

Figure 13 Configuration of feedforward capacitor, Cff.

Table 2 Selection of m

Vo	m
$3.0\text{ V} \leq V_o \leq 6.0\text{ V}$	0.3
$1.2\text{ V} < V_o < 3.0\text{ V}$	0.5
$V_o \leq 1.2\text{ V}$	0.7

Design example

13 Design example

In this section, an example is used to demonstrate how to design a buck regulator with the IR3846A. The application circuit is shown in Figure 14. The design specifications are given below:

- $PV_{IN} = 12\text{ V} (\pm 10\%)$
- $V_o = 1.2\text{ V}$
- $I_o = 40\text{ A}$
- V_o ripple voltage = $\pm 1\%$ of V_o
- Load transient response = $\pm 3\%$ of V_o with a step load current = 14 A and slew rate = $2.5\text{ A}/\mu\text{s}$

13.1 Enabling the IR3846A

The IR3846A has a precise Enable threshold voltage, which can be used to implement a UVLO of the input bus voltage by connecting the EN pin to PV_{IN} with a resistor divider, as shown in Configuration 2 of Figure 8. The Enable feedback resistor, R_{EN1} and R_{EN2} , can be calculated as follows.

$$PV_{in(\min)} \times \frac{R_{EN2}}{R_{EN1} + R_{EN2}} \geq V_{EN(\max)}$$

$$R_{EN2} \geq R_{EN1} \times \frac{V_{EN(\max)}}{PV_{in(\min)} - V_{EN(\max)}}$$

Where $V_{EN(\max)}$ is the maximum spec of the Enable-start-threshold as defined in Section 7.2. For $PV_{in(\min)} = 10.8\text{ V}$, select $R_{EN1} = 49.9\text{ k}\Omega$ and $R_{EN2} = 7.5\text{ k}\Omega$.

13.2 Selecting Input Capacitors

Without input capacitors, the pulse current of the Control MOSFET is provided directly from the input supply. Due to the impedance of the cable, the pulse current can cause disturbance on the input voltage and potential EMI issues. The input capacitors filter the pulse current, resulting in almost constant current from the input supply. The input capacitors should be selected to tolerate the input pulse current, and to reduce the input voltage ripple. The RMS value of the input ripple current can be expressed by:

$$I_{RMS} = I_o \times \sqrt{D \times (1 - D)}$$

$$D = \frac{V_o}{PV_{in}}$$

Where I_{RMS} is the RMS value of the input capacitor current. I_o is the output current and D is the Duty Cycle. For $I_o = 40\text{ A}$ and $D_{(\max)} = 0.1$, the resulting RMS current flowing into the input capacitor is $I_{rms} = 12\text{ A}$.

To meet the requirement of the input ripple voltage, the minimum input capacitance can be calculated as follows.

$$C_{in(\min)} > \frac{I_o \times (1 - D) \times D}{f_{sw} \times (\Delta PV_{in} - ESR \times I_o \times (1 - D))}$$

Where ΔPV_{IN} is the maximum allowable peak-to-peak input ripple voltage, and ESR is the equivalent series resistance of the input capacitors. Ceramic capacitors are recommended due to low ESR, ESL and high RMS current capability. For $I_o = 40\text{ A}$, $F_{sw} = 600\text{ kHz}$, $ESR = 2\text{ m}\Omega$, and $\Delta PV_{IN} = 240\text{ mV}$, $C_{in(\min)} > 36\text{ }\mu\text{F}$. To account for the

Design example

derating of ceramic capacitors under a bias voltage, eight 22 $\mu\text{F}/0805/25\text{V}$ MLCC are used for the input capacitors. In addition, a bulk capacitor is recommended if the input supply is not located close to the voltage regulator.

13.3 Inductor Selection

The inductor is selected based on output power, operating frequency and efficiency requirements. A low inductor value results in a large ripple current, lower efficiency and high output noise, but helps with size reduction and transient load response. Generally, the desired peak-to-peak ripple current in the inductor (Δi) is found between 20% and 50% of the output current.

The inductor saturation current must be higher than the maximum spec of the OCP limit plus the peak-to-peak inductor ripple current. For some core material, inductor saturation current may decrease with increasing temperature. It is important to check the inductor saturation current at the maximum operating temperature.

The inductor value for the desired operating ripple current can be determined using the following relations:

$$L = (PV_{in(max)} - V_o) \times \frac{D_{min}}{\Delta i_{L(max)} \times F_{sw}}$$

$$D_{min} = \frac{V_o}{PV_{in(max)}}$$

$$I_{sat} \geq OCP_{max} + \Delta i_{L(max)}$$

Where: $PV_{in(max)}$ = Maximum input voltage; $\Delta i_{L(max)}$ = Maximum peak-to-peak inductor ripple current; OCP_{max} = maximum spec of the OCP limit as defined in Section 7.2; and I_{sat} = inductor saturation current. In this case, select inductor $L = 150 \text{ nH}$ to achieve $\Delta i_{L(max)} = 30\%$ of $I_{o(max)}$. The I_{sat} should be no less than 74 A.

13.4 Output Capacitor Selection

The output capacitor selection is mainly determined by the output voltage ripple and transient requirements.

To satisfy the V_o ripple requirement, C_o should satisfy the following criterion:

$$C_o > \frac{\Delta i_{Lmax}}{8 \times \Delta V_{or} \times f_{sw}}$$

Where ΔV_{or} is the desired peak-to-peak output ripple voltage. For $\Delta i_{L(max)} = 12 \text{ A}$, $\Delta V_{or} = 12 \text{ mV}$, $f_{sw} = 600 \text{ kHz}$, C_o must be larger than 200 μF . The ESR and ESL of the output capacitors, as well as the parasitic resistance or inductance due to PCB layout, can also contribute to the output voltage ripple. It is suggested to use Multi-Layer Ceramic Capacitor (MLCC) for their low ESR, ESL and small size.

To meet the transient response requirements, the output capacitors should also meet the following criterion:

$$C_o > \frac{L \times \Delta I_{o(max)}^2}{2 \times \Delta V_{oL} \times V_o}$$

Where ΔV_{oL} is the allowable V_o deviation during the load transient. $\Delta I_{o(max)}$ is the maximum step load current. Please note that the impact of ESL, ESR, control loop response, transient load slew rate, and PWM latency is not considered in the calculation shown above. Extra capacitance is usually needed to meet the transient requirements. As a rule of thumb, we can triple the C_o that is calculated above as a starting point, and then optimize the design based on bench measurement. In this case, to meet the transient load requirement (i.e. $\Delta V_{oL} = 30 \text{ mV}$, $\Delta I_{o(max)} = 14 \text{ A}$), select $C_o = \sim 600 \mu\text{F}$. For more accurate estimation of C_o , simulation tools should be used to aid the design.

Design example

13.5 Output Voltage Programming

Output voltage can be programmed with an external voltage divider. The FB voltage is compared to an internal reference voltage of 0.6 V. The divider ratio is set to provide 0.6 V at the FB pin when the output is at its desired value. The calculation of the feedback resistor divider is shown below.

$$V_o = V_{ref} \times \left(1 + \frac{R_{FB1}}{R_{FB2}}\right)$$

Where R_{FB1} and R_{FB2} are the top and bottom feedback resistors. Select $R_{FB1} = 16.2 \text{ k}\Omega$ and $R_{FB2} = 16.2 \text{ k}\Omega$, to achieve $V_o = 1 \text{ V}$. The same resistor divider can be used at the VSNS pin to achieve the same voltage scaling factor.

13.6 Feedforward Capacitor

A small MLCC capacitor, C_{ff} , can be placed in parallel with the top feedback resistor, R_{FB1} , to improve the transient response. Based on Section 12.14, C_{ff} can be selected using the following formula.

$$R_{FB1}C_{ff} = \frac{\sqrt{L_o C_o}}{0.7 \times 4.9}$$

With $L_o = 150 \text{ nH}$, $C_o = 600 \text{ }\mu\text{F}$ and $R_{FB1} = 16.2 \text{ k}\Omega$, $C_{ff} = \sim 150 \text{ pF}$. C_{ff} can be further optimized based on bench testing of transient load response.

13.7 Bootstrap Capacitor

For most applications, a 0.1 μF ceramic capacitor is recommended for bootstrap capacitor placed between SW and BOOT.

13.8 VIN and VCC/LDO bypass Capacitor

Please see the recommendation in Section 12.7. A 10 μF MLCC is selected for the VCC/LDO bypass capacitor and a 4.7 μF MLCC is selected for the VIN bypass capacitor.

14 Application Information

14.1 Application Diagram

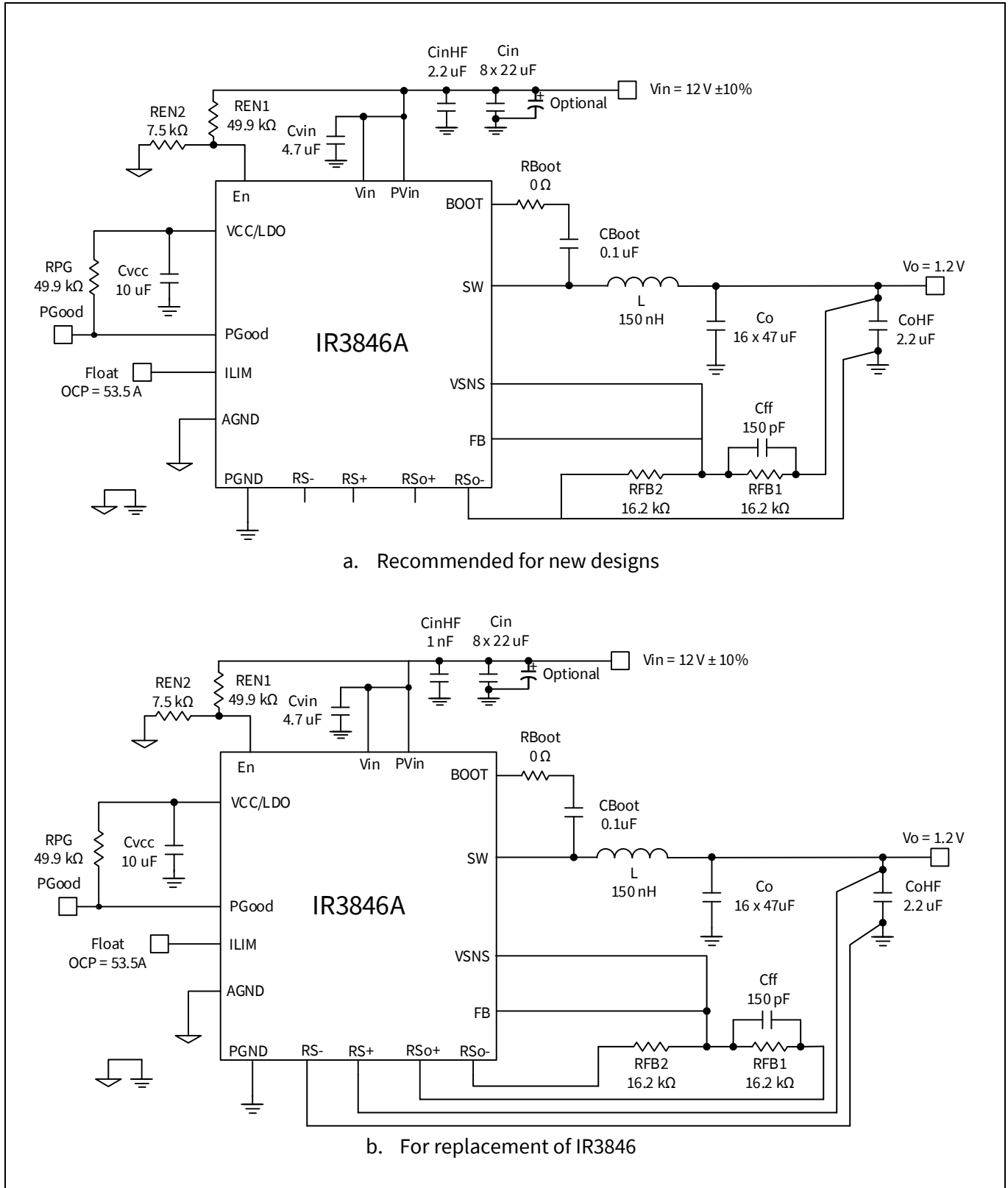

Figure 14 Application diagram of IR3846A. $P_{VIN} = 12V$, $V_o = 1.2V$, $I_o = 40A$, $f_{sw} = 600kHz$.

Application Information

14.2 Typical Operating Waveforms

PVIN = VIN = 12.0 V, Vo = 1.2 V, Io = 0 – 40 A, Fsw = 600 kHz, Room Temperature, no airflow

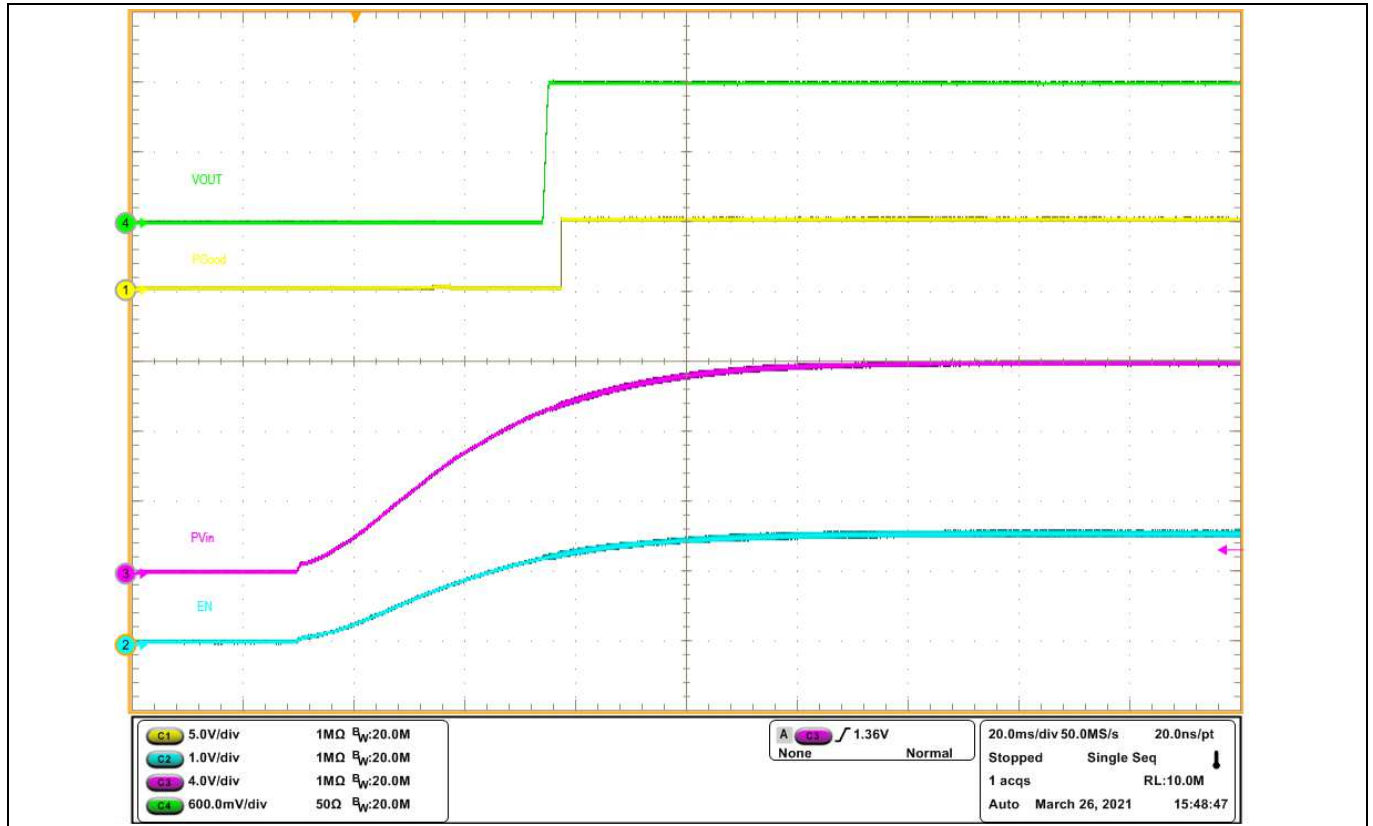

Figure 15 Start up at 40 A Load, (Ch1: PGood, Ch2: Enable, Ch3: PVIN, Ch4: Vout)

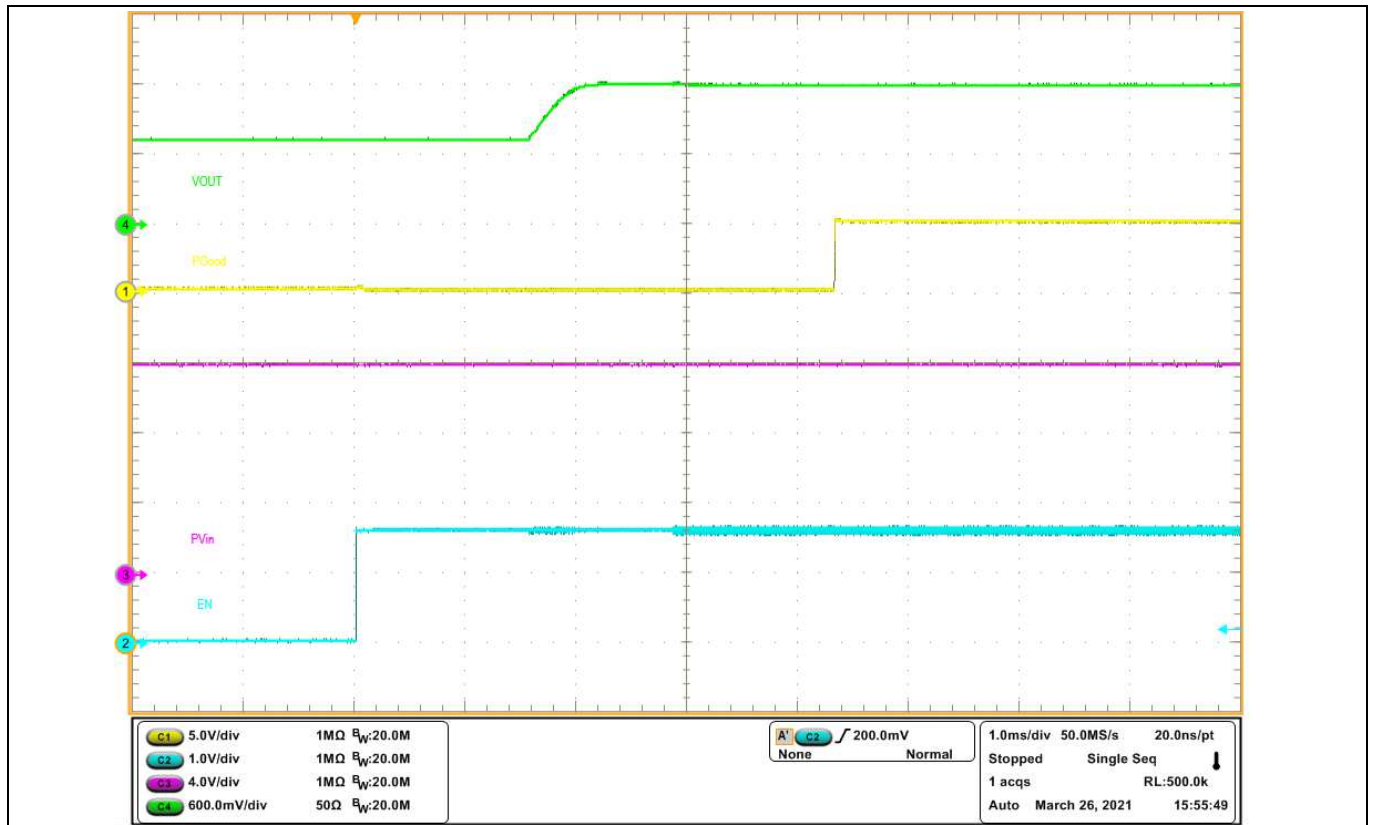

Figure 16 Pre-bias Start up at 0 A Load, (Ch1: PGood, Ch2: Enable, Ch3: PVIN, Ch4: Vout)

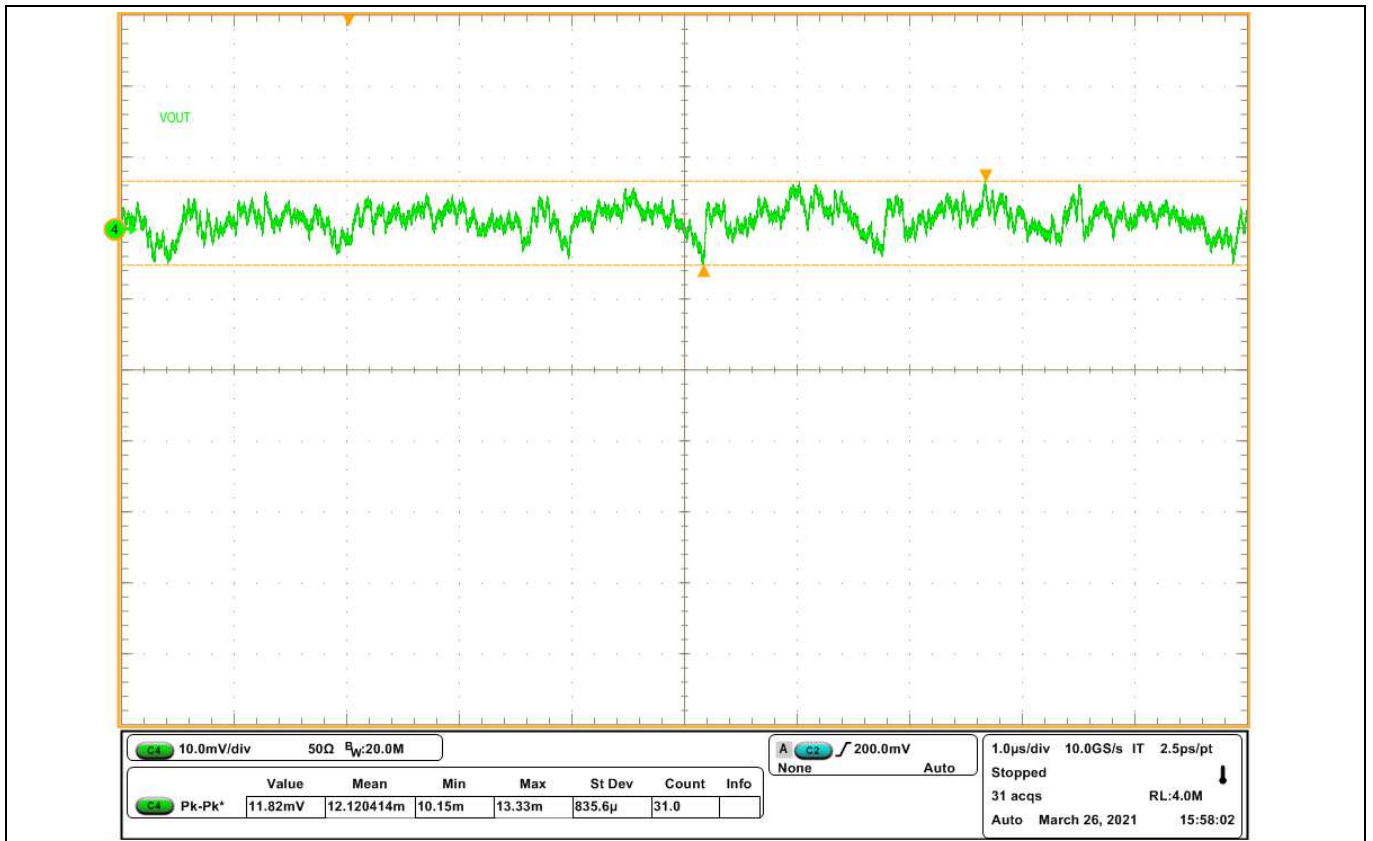

Figure 17 Vout ripple at 40 A Load, fsw = 600 kHz, (Ch4: Vo)

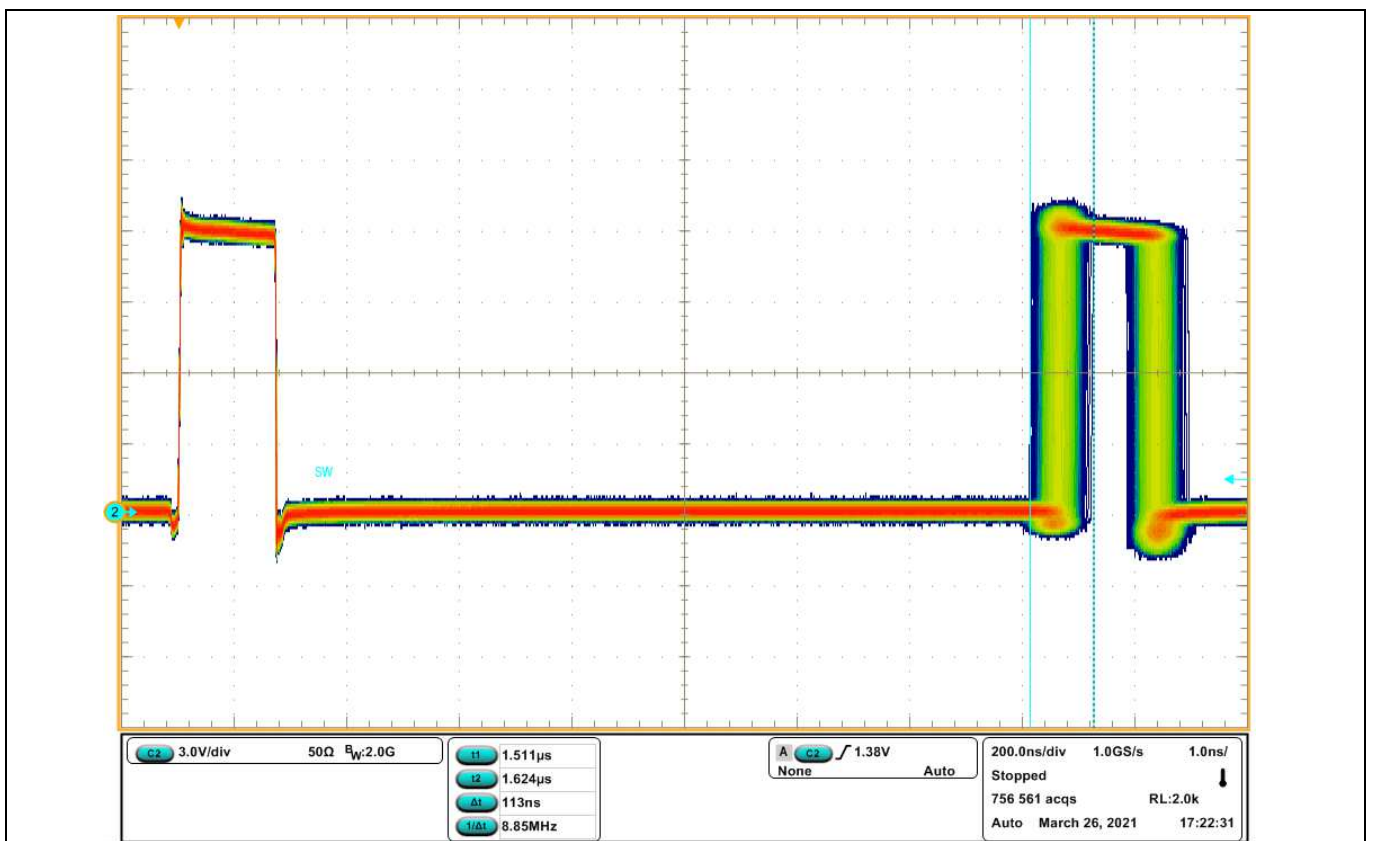

Figure 18 SW node, 40 A load, fsw = 600 kHz, (Ch2: SW)

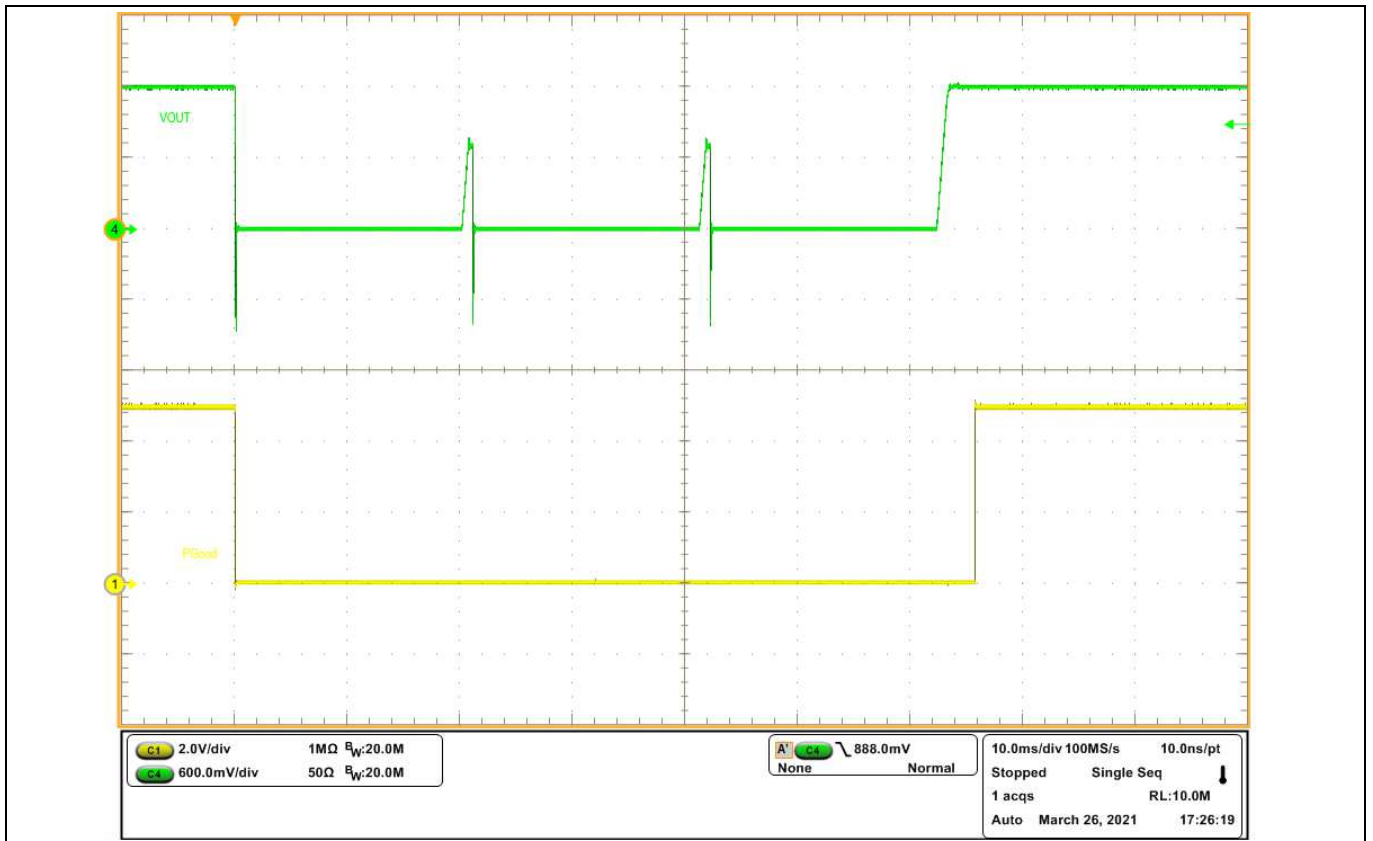

Figure 19 Short circuit and UVP (Hiccup), (Ch1: PGood, Ch4: Vo)

Application Information

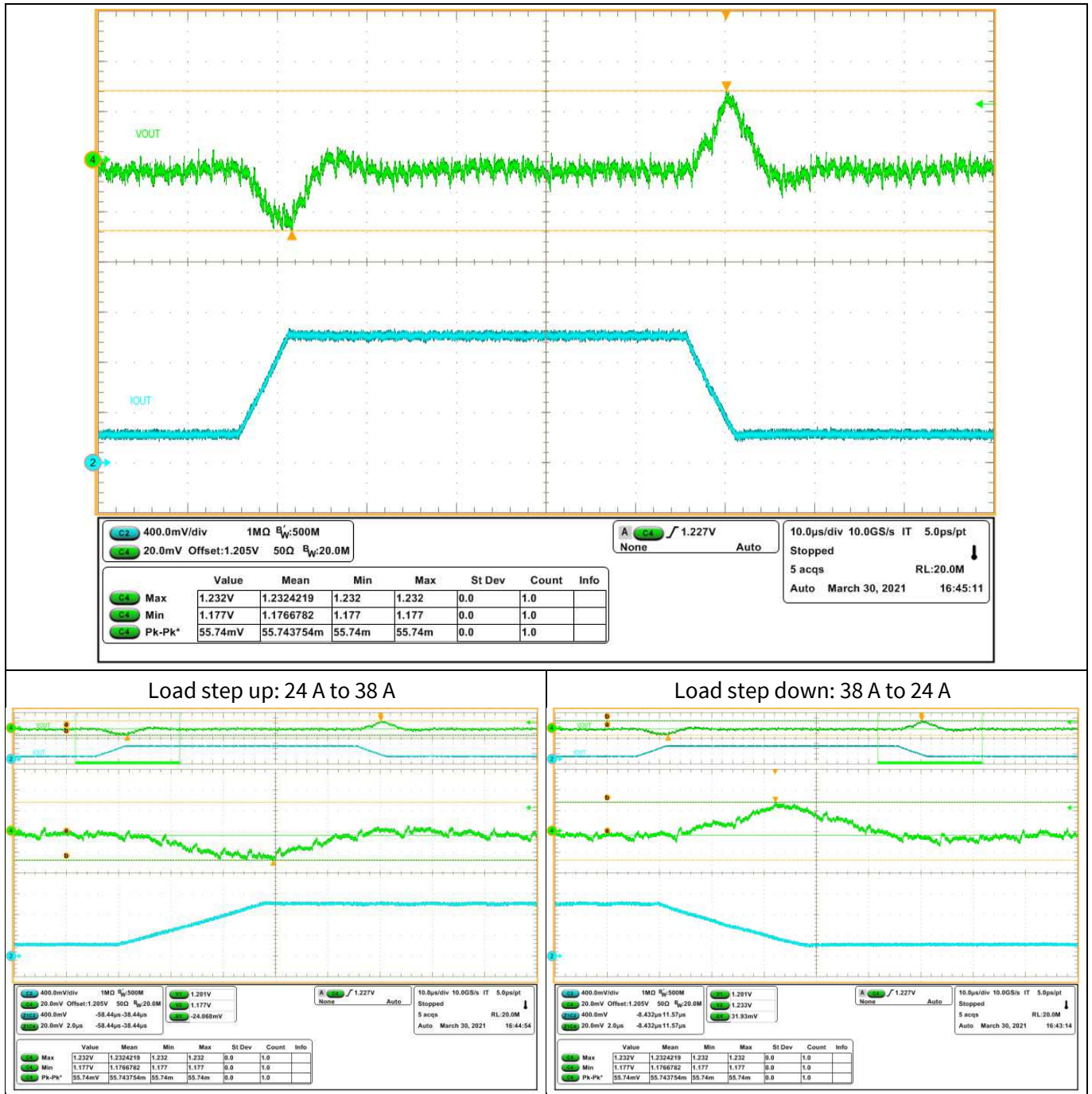

Figure 20 Transient response at 14 A step load current at 2.5 A/us: $I_o = 24\text{ A} - 38\text{ A}$, (Ch4: V_o , Ch2: I_{out}), pk-pk: 55.74mV, fsw = 600 kHz (Note 12)

Note:

12. The load transient test is performed using an intel mini-slammer and a DC electronic load. The load transient of 14 A was applied using an intel mini-slammer, i.e., a 4 A to 18 A load step at 2.5 A/us. A static load of 20 A was applied using the DC electronic load.

15 Layout Recommendations

PCB layout is very important when designing high frequency switching converters. Layout will affect noise pickup and can cause a good design to perform with less than expected results. The following design guidelines are recommended to achieve the best performance.

- Bypass capacitors, including input/output capacitors, VIN and VCC bypass capacitors, should be placed as close to the corresponding pins as possible.
- Place bypass capacitors from IR3846A power input (Drain of Control MOSFET) to PGND (Source of Synchronous MOSFET) to reduce noise and ringing in the system. The output capacitors should be terminated to a ground plane that is away from the input PGND to mitigate switching spikes on the Vout. The VIN and VCC bypass capacitors should be terminated to PGND.
- Place a boot strap capacitor as close as possible to IR3846A BOOT and SW pins to minimize loop inductance.
- SW node copper should only be routed on the top layer to minimize the impact of switching noise.
- Connect the AGND pin to the PGND pad through a single point connection. On the IR3846A demo board, AGND pin is connected to the exposed AGND pad (Pin 13) and then connected to the internal PGND layer through thermal via holes.
- Via holes can be placed on PVIN and PGND pads to aid thermal dissipation.
- Wide copper polygons are desired for PVIN and PGND connections in favor of power loss reduction and thermal dissipation. Sufficient via holes should be used to connect power traces on between different layers.
- Single-ended Vo sensing is often used for local sensing. To implement this configuration, following design guidelines should be followed.
 - The output voltage can be sensed from a high-frequency bypass capacitor of 0.1 μ F or higher, through a 15 mil PCB trace.
 - Keep the Vout sense line away from any noise sources and shield the sense line with ground planes.
 - The sense trace is connected to a feedback resistor divider with the lower resistor terminated at RSo- (or RS-) pin.
 - Short RSo- (or RS-) pin and AGND pin with a short trace.
- If it is required to sense the output voltage at a remote location, pseudo remote sensing can be implemented as follows, as illustrated in [Figure 14](#).
 - A pair of PCB traces with 15 mil trace width, running close to each other and away from any noise sources such as inductor and SW nodes, should be used to implement Kelvin sensing of the voltage across a high bypass capacitor of 0.1 μ F or higher.
 - The ground connection of the remote sensing signal must be terminated at RSo- (or RS-) pin.
 - The Vout connection of the remote sensing signal must be connected to the feedback resistor divider with the lower feedback resistor terminated at RSo- (or RS-) pin.
 - Shield the pair of remote sensing lines with ground planes above and below.
 - Do **NOT** connect either of the RSo- and RS- pins to AGND pin in this configuration
- The EN pin and configuration pin ILIM should be terminated to a quiet ground. On the IR3846A standard demo board, they are terminated to the PGND copper plane away from the power current flow. Alternatively, they can be terminated to a dedicated AGND PCB trace.

15.1 Solder Mask

Evaluation has shown that the best overall performance is achieved using the substrate/PCB layout as shown in the following figures. PQFN devices should be placed to an accuracy of 0.050 mm on both X and Y axes. Self-centering behavior is highly dependent on solders and processes, and experiments should be run to confirm the limits of self-centering on specific processes.

Layout Recommendations

Infineon recommends that larger Power or Land Area pads are Solder Mask Defined (SMD). This allows the underlying copper traces to be as large as possible, which helps in terms of current carrying capability and device cooling capability. When using SMD pads, the underlying copper traces should be at least 0.05 mm larger (on each edge) than the openings in the solder mask. This allows for layers to be misaligned by up to 0.1 mm on both axes. Ensure that the solder resist between the smaller signal lead areas is at least 0.15 mm wide due to the high x/y aspect ratio of the solder mask strip.

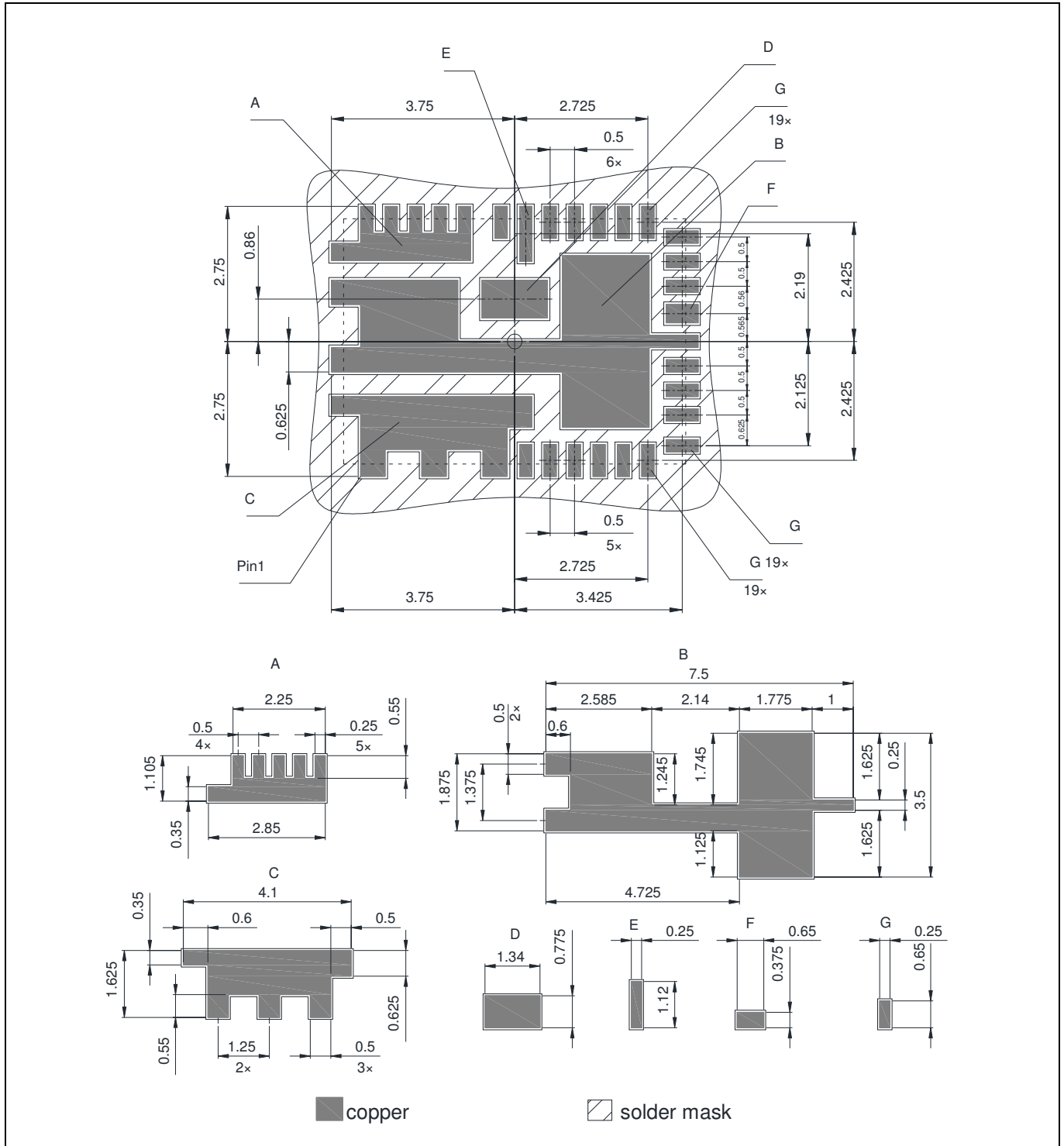

Figure 21 PCB metal and Solder mask (all dimensions in mm)

Package

16 Package

This section includes mechanical and packaging information for the IR3846A.

16.1 Dimensions

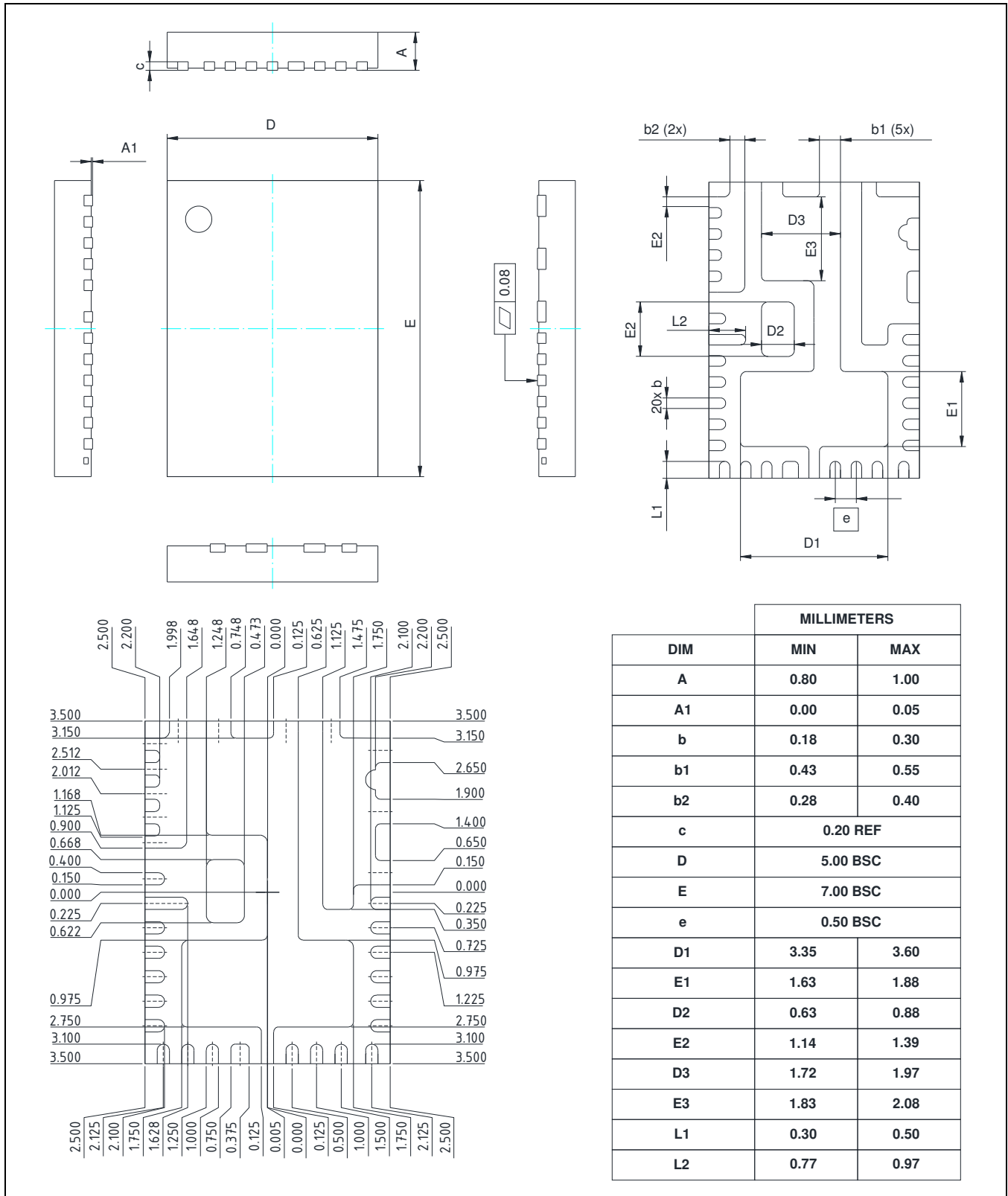

Figure 23 Package Dimensions (all dimensions in mm)

17 Environmental Qualifications

Qualification Level		Industrial	
Moisture Sensitivity		PQFN Package	JEDEC Level 2 @ 260 °C
ESD	Human Body Model	ANSI/ESDA/JEDEC JS-001, Level 2 (2000 V to < 4000 V)	
	Charged Device Model	ANSI/ESDA/JEDEC JS-002, Class C3 (≥ 1000 V)	
RoHS2 Compliant		Yes, with exemption 7a.	

Revision History

IR3846A

Revision: 2021-11-22, Rev. 2.1

Previous Revision

Revision	Date	Subjects (major changes since last revision)
2.0	2021-10-06	Release of final datasheet
2.1	2021-11-22	1. ESD HBM updated to Level 2 (2000 V to < 4000 V) 2. Removed the term "Fixed" when describing switching frequency.

Trademarks

All referenced product or service names and trademarks are the property of their respective owners.

We Listen to Your Comments

Any information within this document that you feel is wrong, unclear or missing at all? Your feedback will help us to continuously improve the quality of this document. Please send your proposal (including a reference to this document) to:

erratum@infineon.com

Published by

Infineon Technologies AG
81726 München, Germany
© 2021 Infineon Technologies AG
All Rights Reserved.

Legal Disclaimer

The information given in this document shall in no event be regarded as a guarantee of conditions or characteristics ("Beschaffenhheitsgarantie").

With respect to any examples, hints or any typical values stated herein and/or any information regarding the application of the product, Infineon Technologies hereby disclaims any and all warranties and liabilities of any kind, including without limitation warranties of non-infringement of intellectual property rights of any third party.

In addition, any information given in this document is subject to customer's compliance with its obligations stated in this document and any applicable legal requirements, norms and standards concerning customer's products and any use of the product of Infineon Technologies in customer's applications.

The data contained in this document is exclusively intended for technically trained staff. It is the responsibility of customer's technical departments to evaluate the suitability of the product for the intended application and the completeness of the product information given in this document with respect to such application.

Information

For further information on technology, delivery terms and conditions and prices please contact your nearest Infineon Technologies Office (www.infineon.com).

Warnings

Due to technical requirements, components may contain dangerous substances. For information on the types in question, please contact the nearest Infineon Technologies Office.

The Infineon Technologies component described in this Data Sheet may be used in life-support devices or systems and/or automotive, aviation and aerospace applications or systems only with the express written approval of Infineon Technologies, if a failure of such components can reasonably be expected to cause the failure of that life-support, automotive, aviation and aerospace device or system or to affect the safety or effectiveness of that device or system. Life support devices or systems are intended to be implanted in the human body or to support and/or maintain and sustain and/or protect human life. If they fail, it is reasonable to assume that the health of the user or other persons may be endangered.