

# MultiCAN

Multi-Controller Area Network



# MultiCAN

## Multi-Controller Area Network

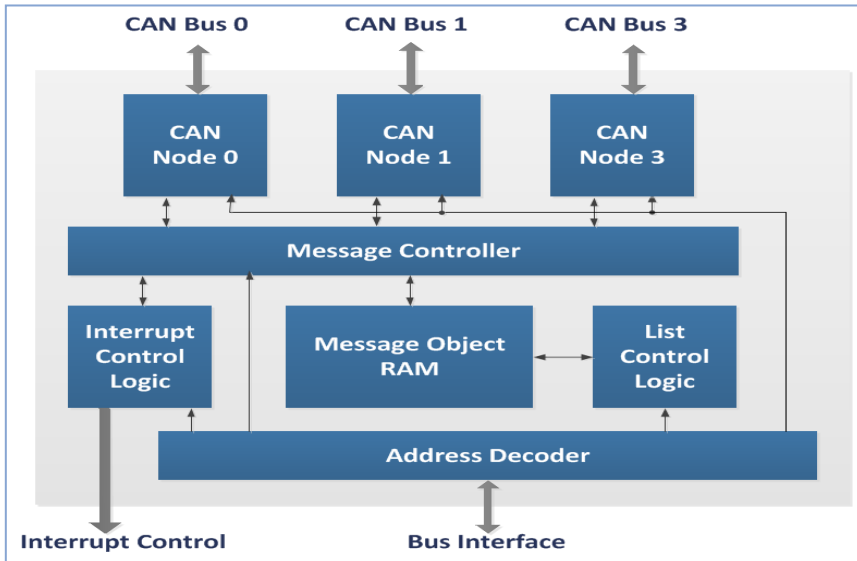

### Highlights

XMC4000 provides a MultiCAN module with up to 3 CAN nodes and a Buffer of 64 Message Objects (MO). It conforms to the specification V2.0 B Active. Data transfer rate up to 1MBaud, separately programmable for each node and it implements automatic FIFO and Gateway function freeing CPU load.

### Key Feature

64 independent MO with ID masking and Time stamp features

3 independent CAN nodes flexibly connected to the MO

Automatic FIFO and Gateway functionality

### Customer Benefits

Free the CPU to MO re-configuration in run time

Dedicated control registers for each CAN node increasing system flexibility

Communication Handled automatically by the module freeing the CPU

# MultiCAN

## 64 Message Objects

- 64 independent MO with ID masking and Time stamp features

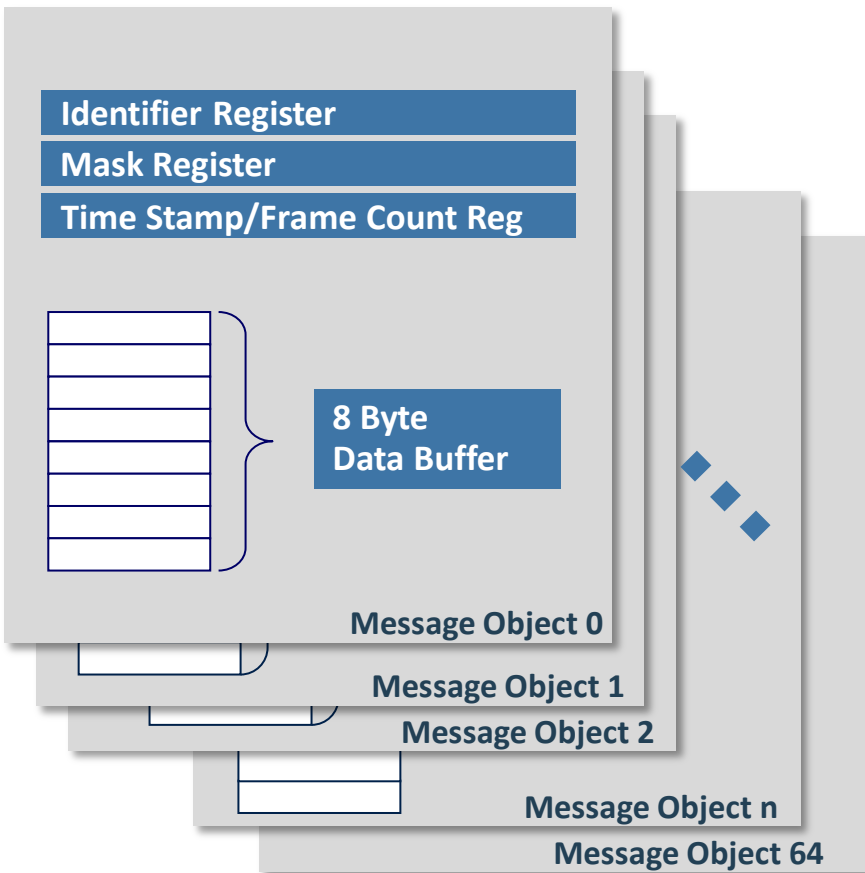

- Each MO has its own Identifier register: 11 or 29 bit ID
- One Mask register per MO which specifies which bits of ID are “don’t care”
- Independent Time stamp and Frame count for each MO: This feature serves to indicate when the message has arrived or when it was transmitted

## 3 independent CAN Nodes

- 3 independent CAN nodes flexibly connected to the MOs
  - Baudrate settings
  - Operation and events control
  - Ports control
  - Error Analysis

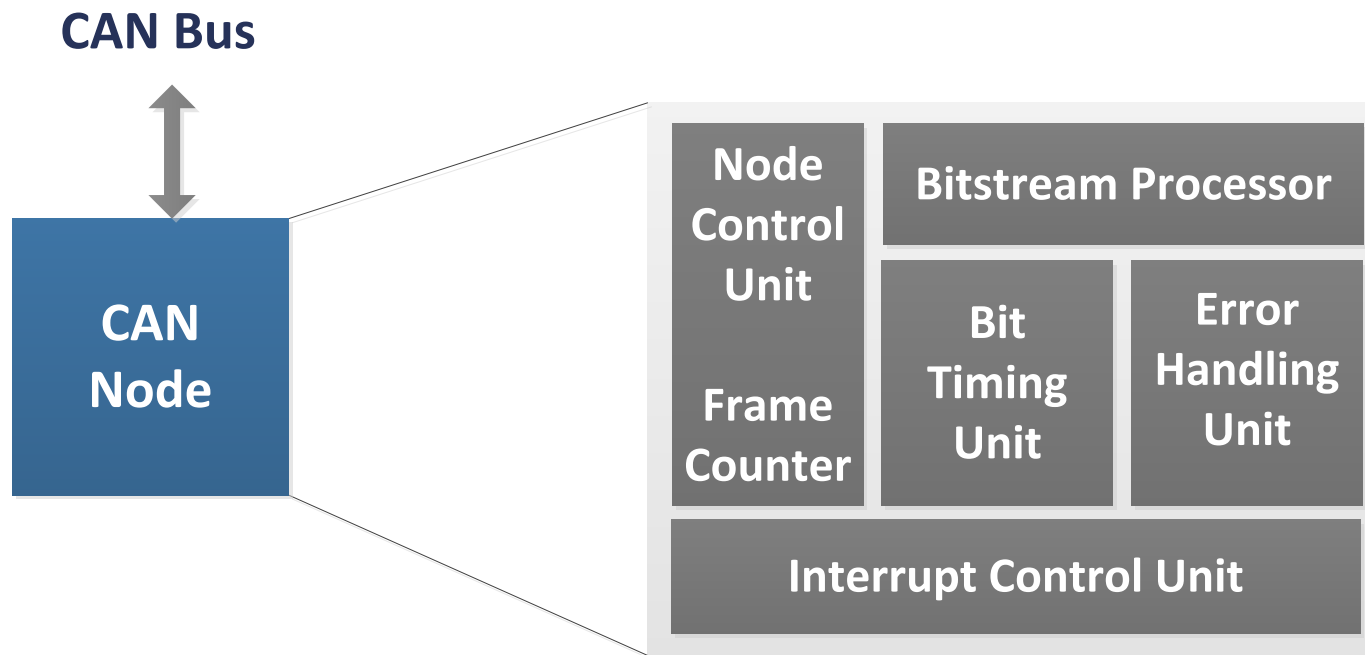

## Automatic FIFO and Gateway functionality (1/2)

### ■ FIFO functionality freeing the CPU:

- Message objects can be combined to build FIFO of a chosen size
- Message objects can be organized as FIFO buffers for transmission and reception
- FIFO interacts with message objects rather than lists

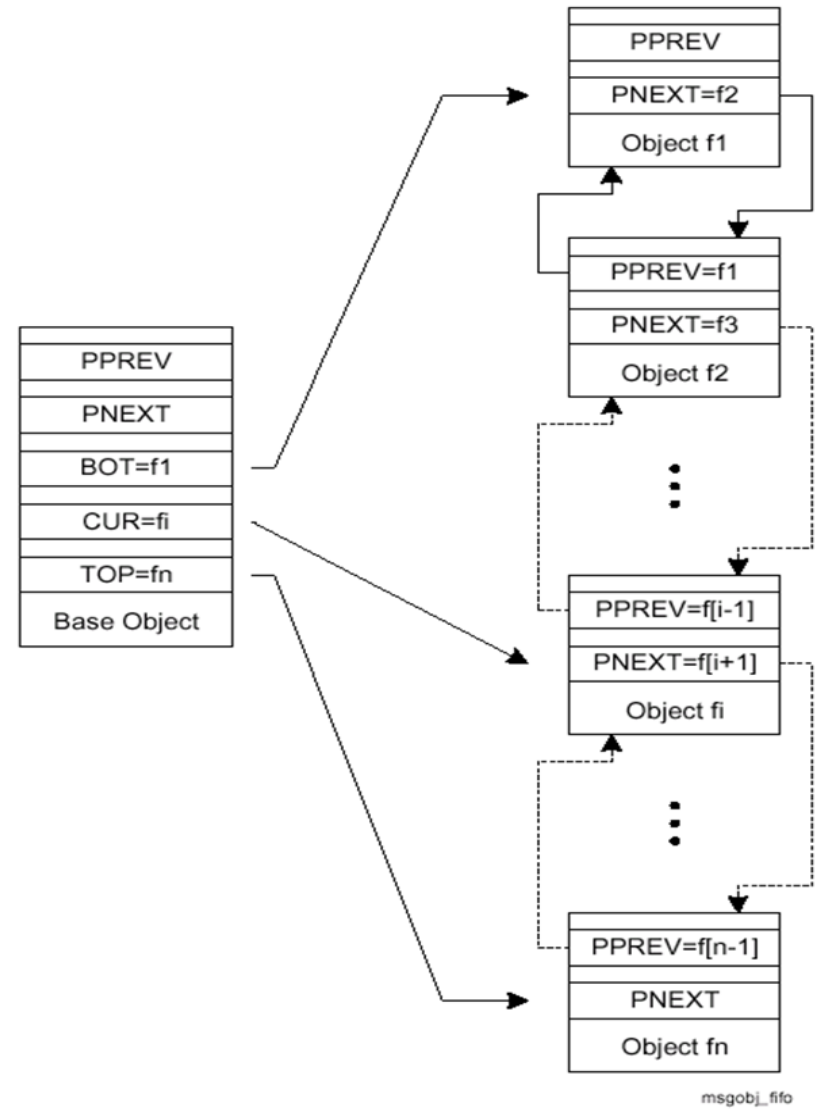

## Automatic FIFO and Gateway functionality (2/2)

- Gateway functionality freeing the CPU:
  - Gateway mode allows transfer of messages between two nodes without CPU intervention.
  - Two nodes may operate at different baud rates
  - Gateway FIFOs can be built.

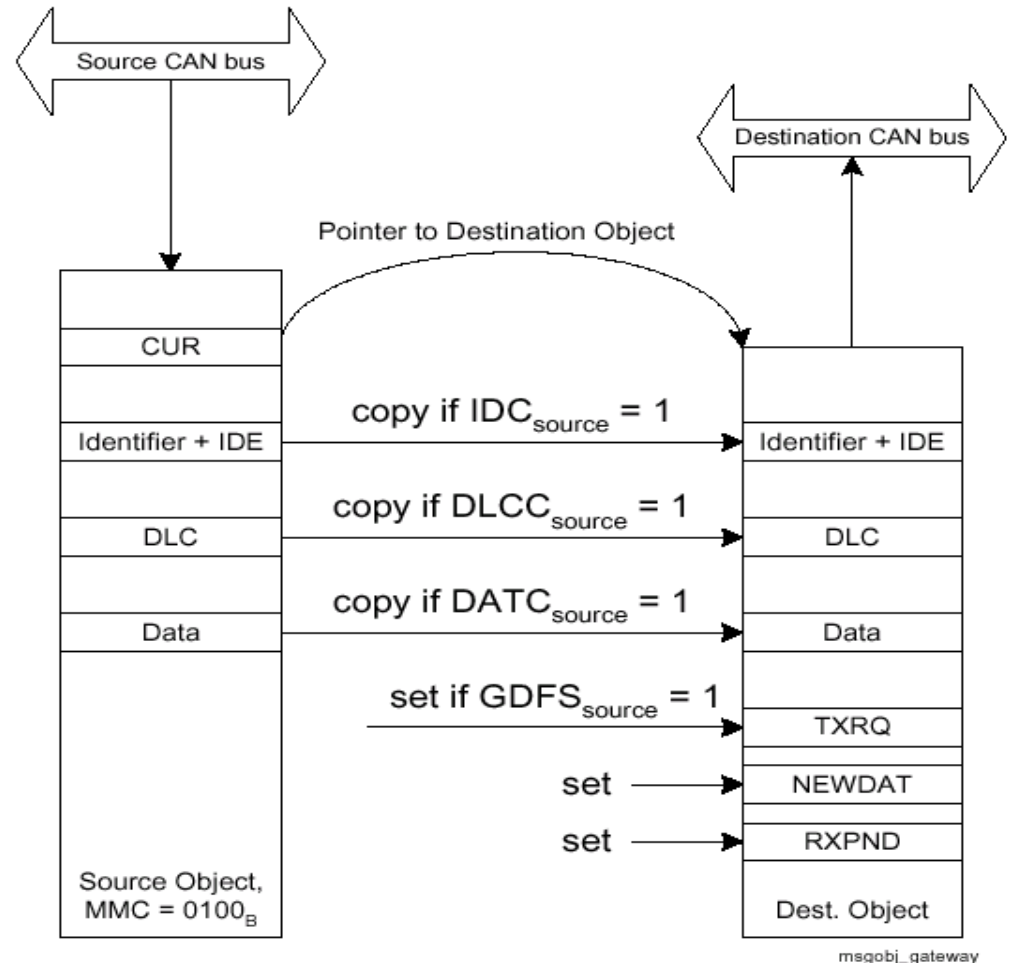

# MultiCAN System Integration

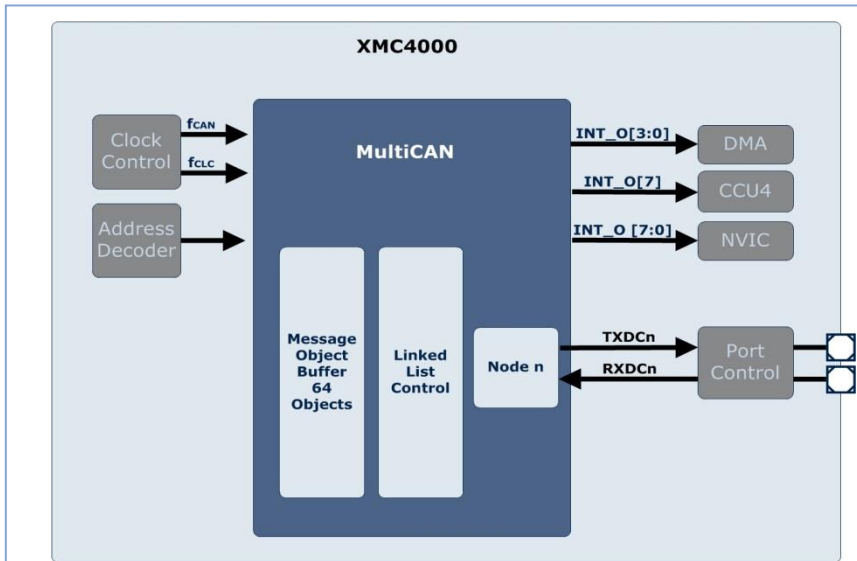

\*) CAN Node instances per device.

Each Transmit and Receive line of every CAN Node is available for several external ports through the port control logic. The Receive input can be easily selectable from the Input multiplexer using the RXSEL bitfield.

The output interrupt signals are available to request Interrupts (NVIC and CPU), DMA transfer requests and as signal trigger the of the CCU4 action.

- Target applications
  - Motor Control
  - Industrial Automation
  - Connectivity
  - General Purpose

# Application Example

## Foreign Remote Requests Using Gateway Mode

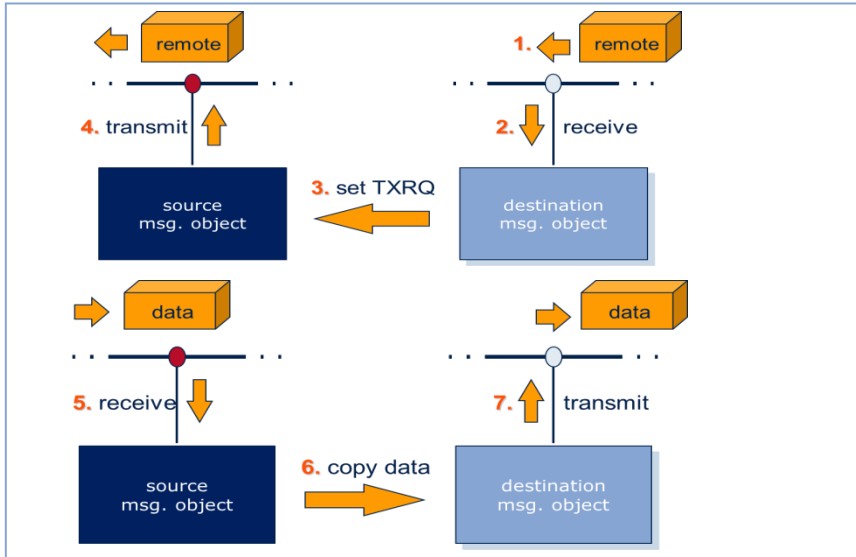

### In Brief

Using the Gateway Mode of the MultiCAN module, for remote frames the foreign remote request mode can be used to handle the data request.

### Overview

The MultiCAN Module offer a so called Gateway Mode to transfer CAN messages from one CAN bus to another without CPU involvement. This offloads the CPU and displaces the workload to hardware.

The foreign remote request feature is especially useful for the gateways to issue a remote request on the source bus after the reception of a remote request on the gateway destination bus.

If foreign remote request mode is enabled, when a Remote Frame has been received on a CAN Node and is stored in a MO, a transmit request (TXRQ) is set to trigger the answer to automatically issue a secondary request. TXRQ is set in the source message object.



# MultiCAN

## Table of contents



- Message Object lists
- Analyzer Mode
- Service request generation
- Flexible Message Masking

# MultiCAN

## Message Object lists (1/2)

- Message object lists
  - 8 Configurable lists available
  - A node is linked to a unique list, and a message object belongs to a maximum 1 list
  - A group of message objects allocated to a unique CAN Node
  - List size is limited only by the number of message objects available

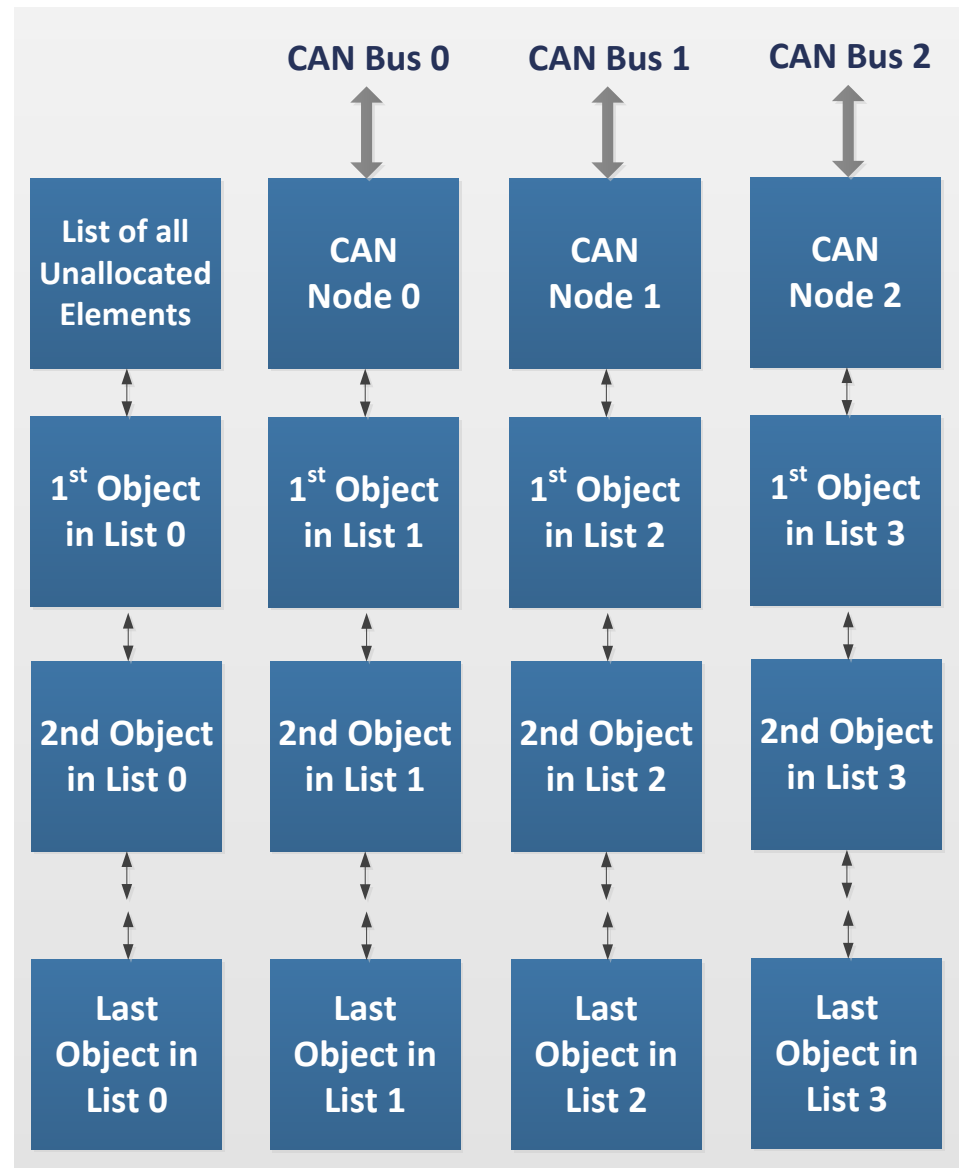

- Double chained connection within the lists  $\uparrow\downarrow$
- Message objects can be shifted from one list to the other. (message objects are used where they are needed)
- All unused message objects do belong to the list of unallocated elements.

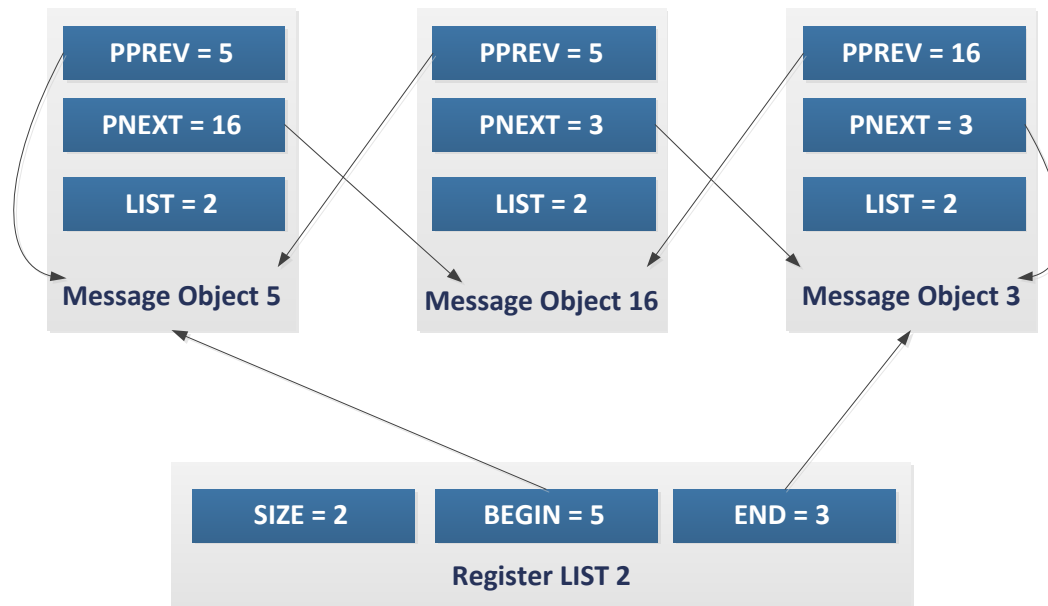

**Double-chained Lists**

# MultiCAN Analyzer Mode

- MultiCAN offers an Analyzer Mode, to support:
  - Listening to the bus, without taking part of the protocol.
  - The CAN node may receive frames but is not allowed to transmit
  - The complete message object functionality is available, but no transmit request will be executed
  - Message objects are appended to a node
  - Problems between message memory and protocol handler can be detected.

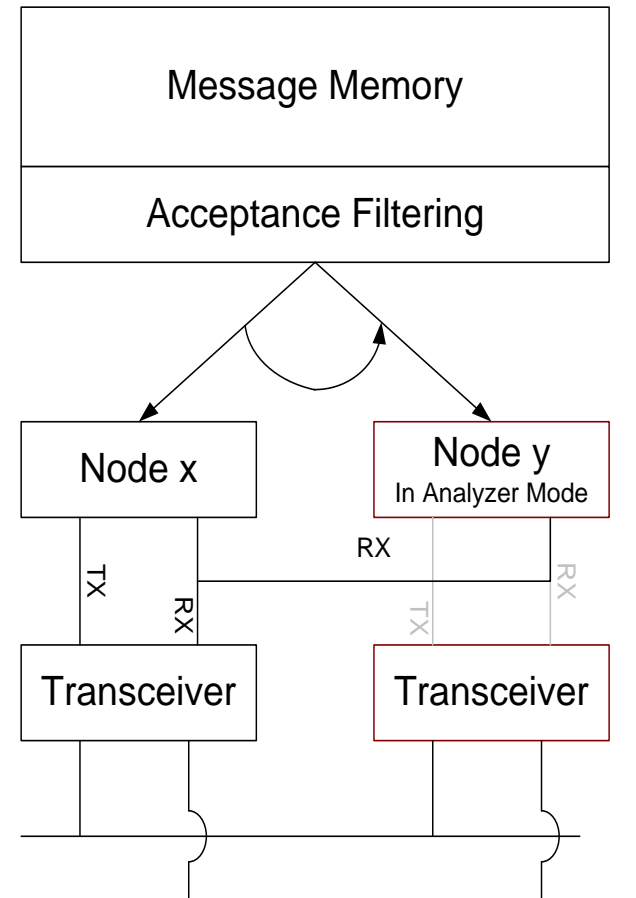

## Service request generation (1/2)

- Highly flexible service request processing
- 140 hardware service requests (SR)
  - 4 SR per node => 12 SR in total
  - 2 SR per message objects => 128 SR in total
- These hardware service requests are compressed to 8 SR output lines
- It is possible to trigger 1 software interrupt

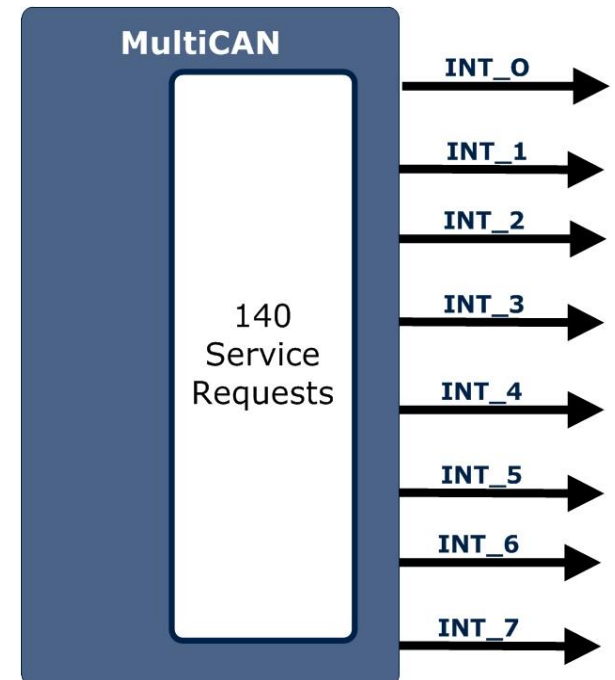

- For each Node:
  - Alert Interrupt
  - Last Error Code Interrupt
  - Transfer OK Interrupt
  - Frame Counter Interrupt
- For each MO:
  - Receive Interrupt
  - Transmit Interrupt

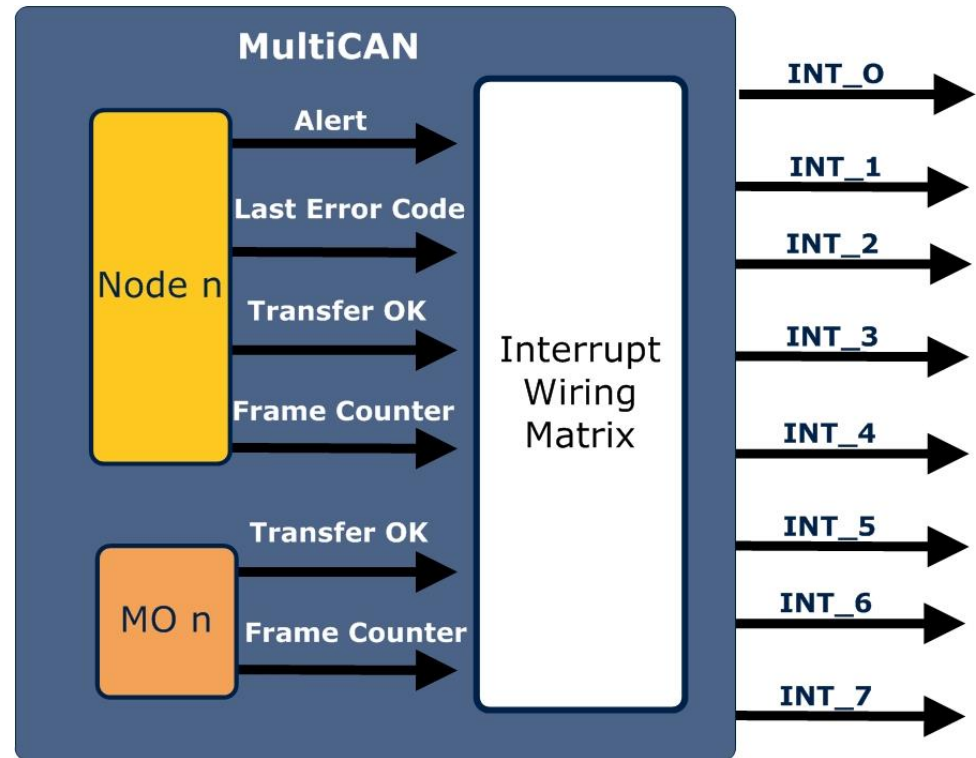

# MultiCAN

## Flexible Message Masking (1/2)

- CAN Module allows Rx ID bits to be selected as “don't care”
  - Allows the reception of a group of messages into 1 Message Object
  - Mask Register defines which ID bits are significant
  - On match, Data and ID Bits are transferred into Message Object

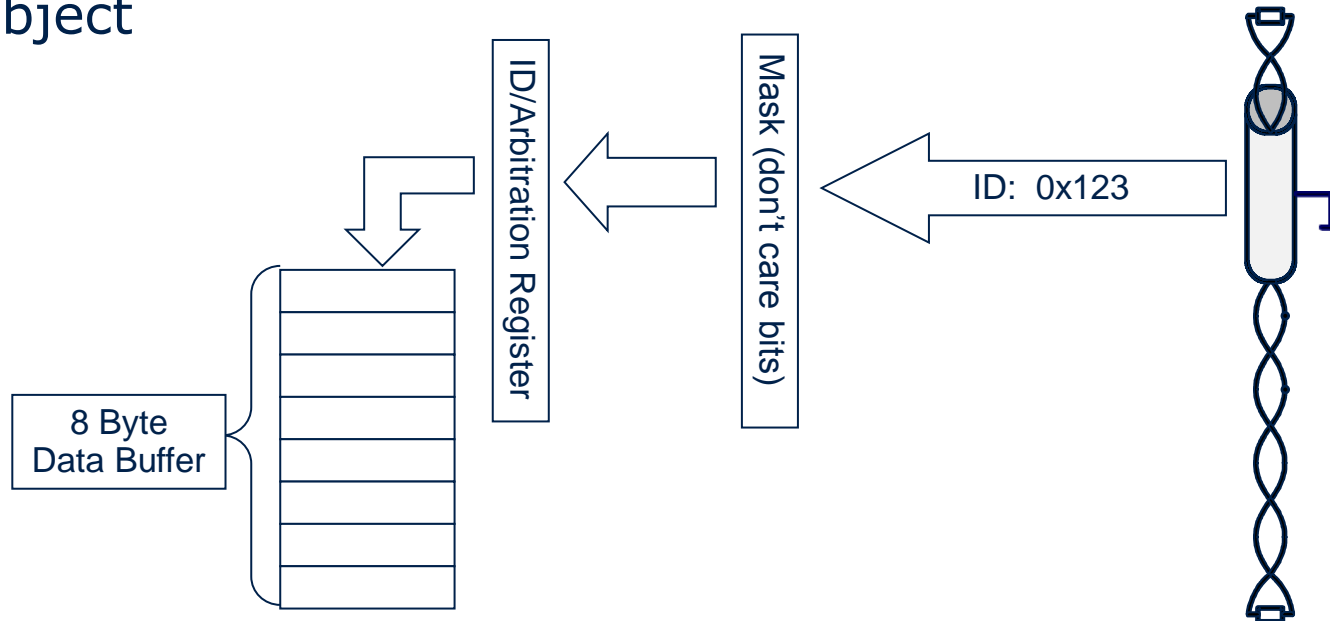

# MultiCAN

## Flexible Message Masking (2/2)



Mask Register (std ID)



= 0x7FC

Message Object Arbitration Register



= 0x490

Resulting ID matches (X = don't care)



---

ID's received:



= 0x490



= 0x491



= 0x492



= 0x493





# ENERGY EFFICIENCY MOBILITY SECURITY

Innovative semiconductor solutions for energy efficiency, mobility and security.

