

# CCU4 Capture and Compare Unit 4

XMC™ microcontrollers  
September 2016



# Agenda

1

Overview

2

Key feature: Modular timer approach with repeated external functions

3

Key feature: Flexible PWM generation

4

Key feature: Flexible capture scheme

5

System integration

6

Application example

# Agenda

1

Overview

2

Key feature: Modular timer approach with repeated external functions

3

Key feature: Flexible PWM generation

4

Key feature: Flexible capture scheme

5

System integration

6

Application example

# CCU4

## Capture/Compare Unit 4

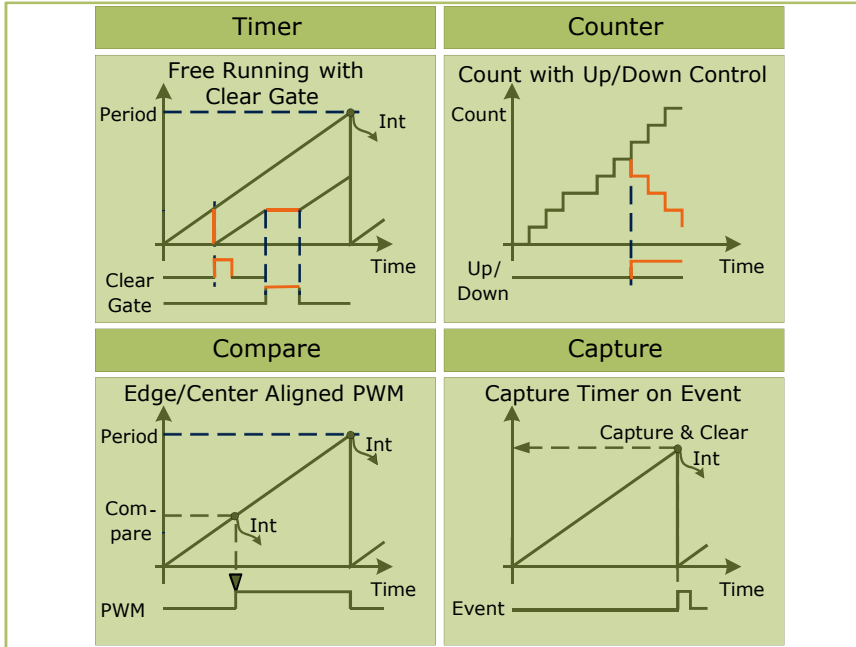

## Highlights

One timer architecture serves any use case. The regular and repetitive slice structure allows portable software and use of code generators.

## Key features

- › CCU4 serves as timer, counter, capture, compare
- › Shadow and buffer mechanism for coherency
- › Interrupt and event generation

## Customer benefits

- › Adjust the timer to the wanted application
- › Synchronize hardware events to software timing for real-time control
- › Indication and propagation of events for highest flexibility

# CCU4

## Capture/Compare Unit 4

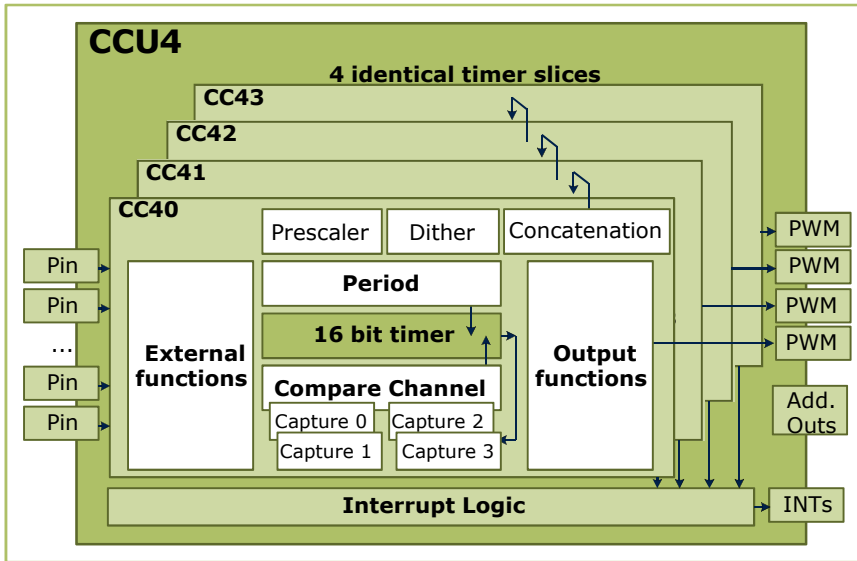

## Highlights

The CCU4 is a flexible timer module, comprised of four identical timer slices tailored for single PWM generation and signal conditioning.

Several input functions can be controlled externally (via pins or other modules) enabling a powerful resource arrangement for each application.

## Key features

- > Modular timer approach with repeated external functions
- > Flexible PWM generation
- > Flexible capture scheme

## Customer benefits

- > Each specific application function can be ported to any of the four timers
- > Accommodation for any type of PWM operation mode
- > Capture scheme can cover a wide range of signal dynamics

# Agenda

1

Overview

2

Key feature: Modular timer approach with repeated external functions

3

Key feature: Flexible PWM generation

4

Key feature: Flexible capture scheme

5

System integration

6

Application example

- › Equal structure and same availability of features for each of the four timer slices
- › Functions controllable via external signals do not depend on the selected signal
- › Portability of code is not dependent on the used timer slice
- › High amount of configurable external functions (11) make each timer slice a very flexible HW resource for signal conditioning

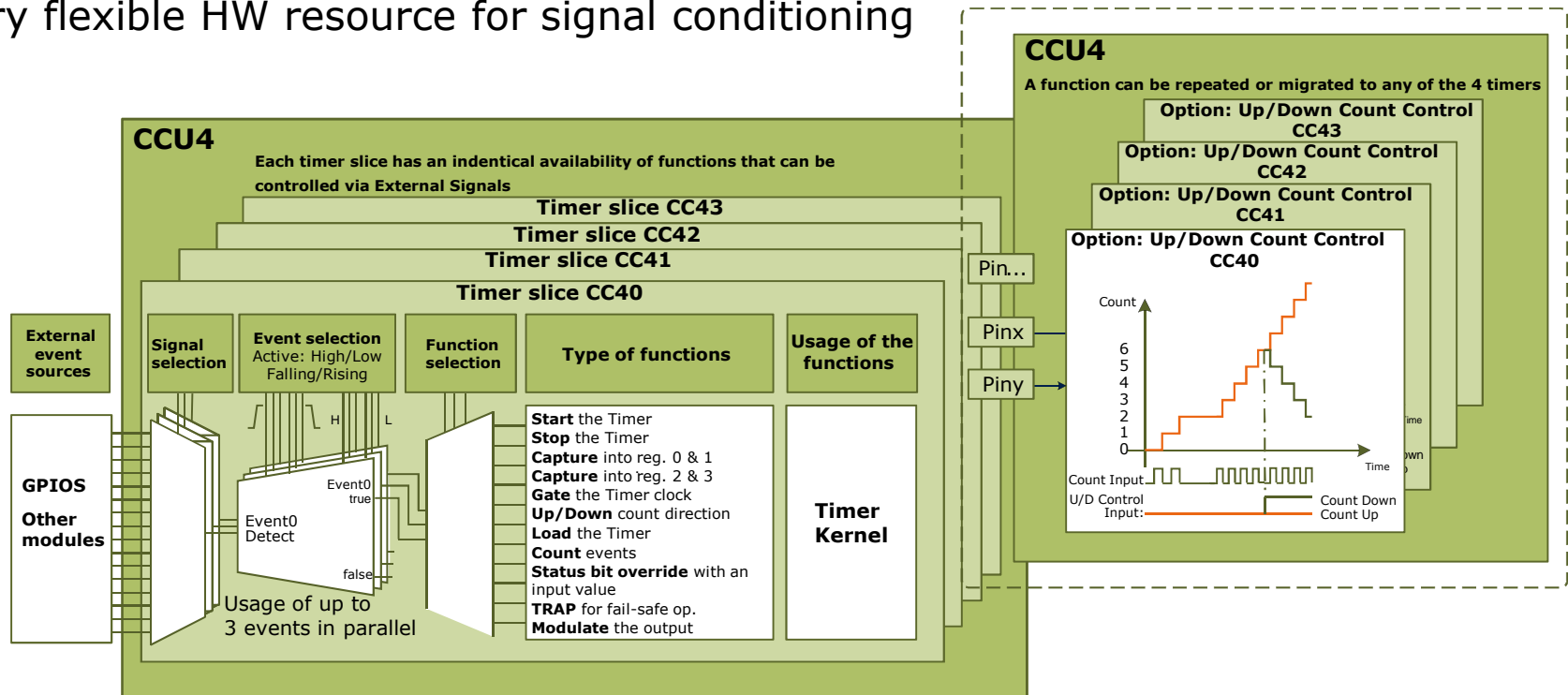

# Agenda

- 1 Overview
- 2 Key feature: Modular timer approach with repeated external functions
- 3 **Key feature: Flexible PWM generation**
- 4 Key feature: Flexible capture scheme
- 5 System integration
- 6 Application example



# CCU4

## Flexible PWM generation

- Each timer slice of the CCU4 can operate in center aligned or edge aligned mode
- Additional operation modes like single shot, counting or dithering modes are also available
- Update of the duty cycle and period can be done on-the-fly to accommodate different operation requirements
- Additional external controllable functions give another degree of PWM manipulation (e.g. timer gate, timer load, timer clear, etc.)

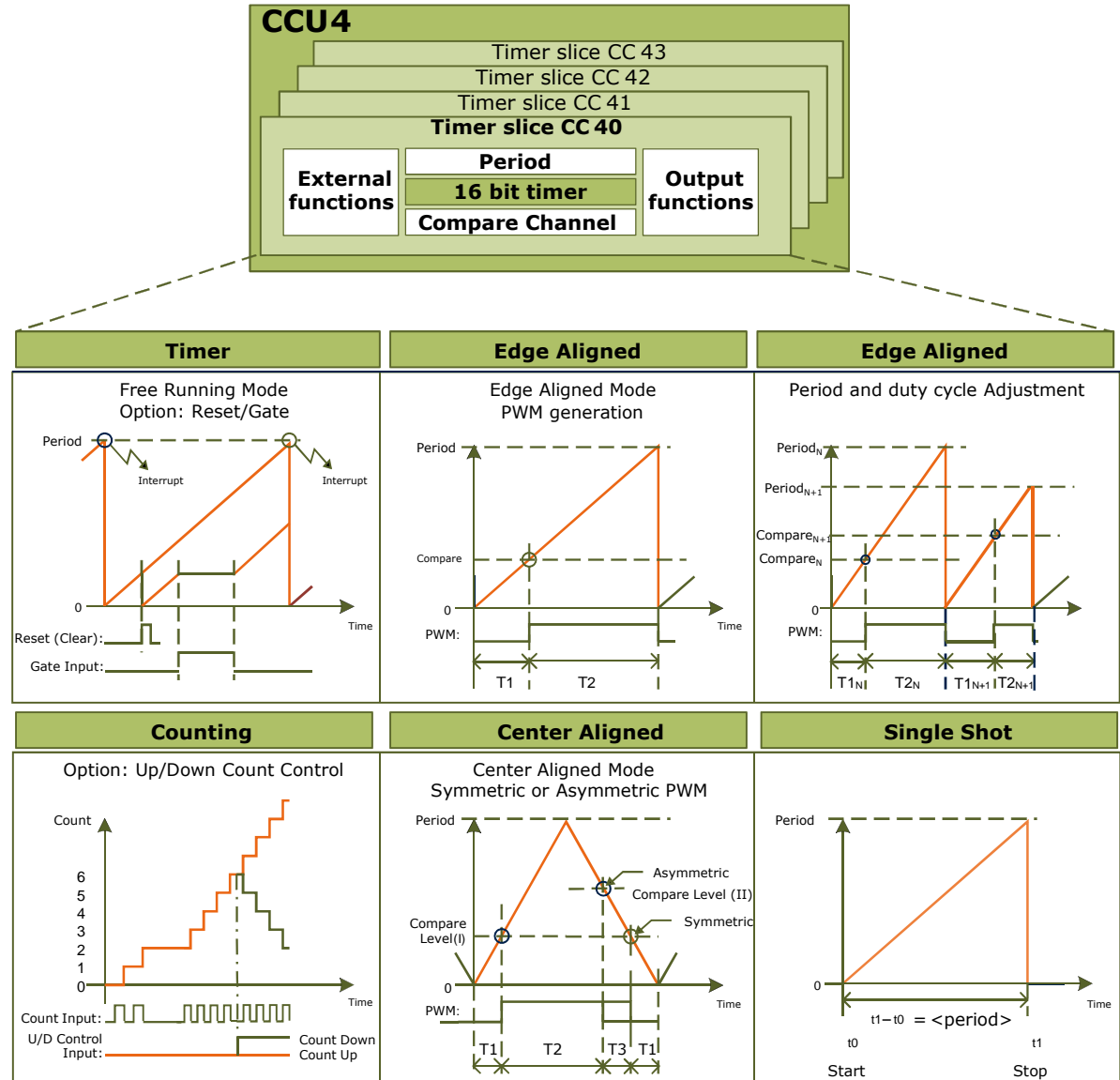

# Agenda

1

Overview

2

Key feature: Modular timer approach with repeated external functions

3

Key feature: Flexible PWM generation

4

Key feature: Flexible capture scheme

5

System integration

6

Application example

# CCU4

## Flexible capture scheme

- › Each timer slice of the CCU4 can operate in compare and/or capture mode
- › Possibility of using the available four capture registers in two modes:
  - Two capture triggers
  - One capture trigger
- › A FIFO structure, with a full/empty control, decreases the load on the CPU when reading back fast capture trigger info:
  - Depth of 2
  - Depth of 4
- › FIFO structure will always return the oldest captured value

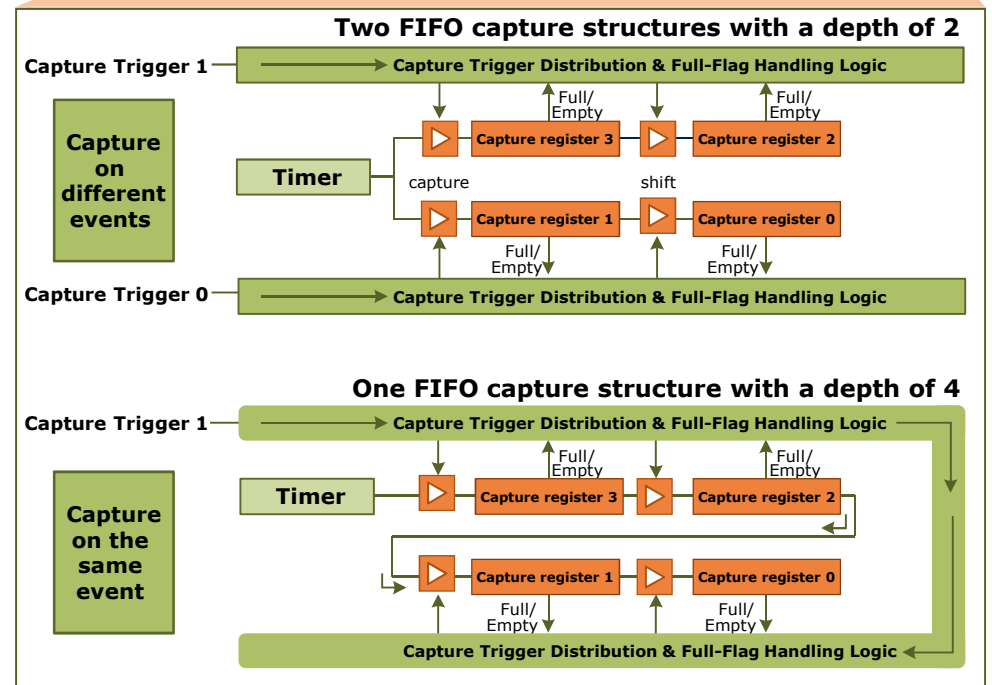
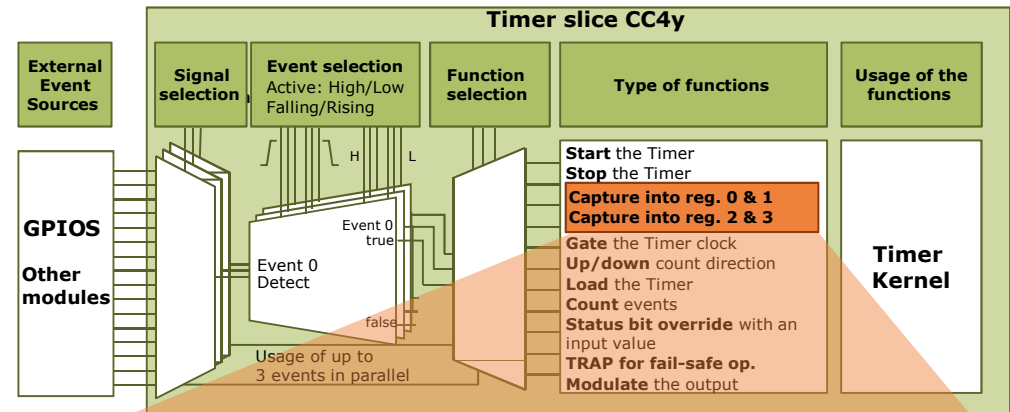

# Agenda

1

Overview

2

Key feature: Modular timer approach with repeated external functions

3

Key feature: Flexible PWM generation

4

Key feature: Flexible capture scheme

5

System integration

6

Application example

# CCU4

## System integration

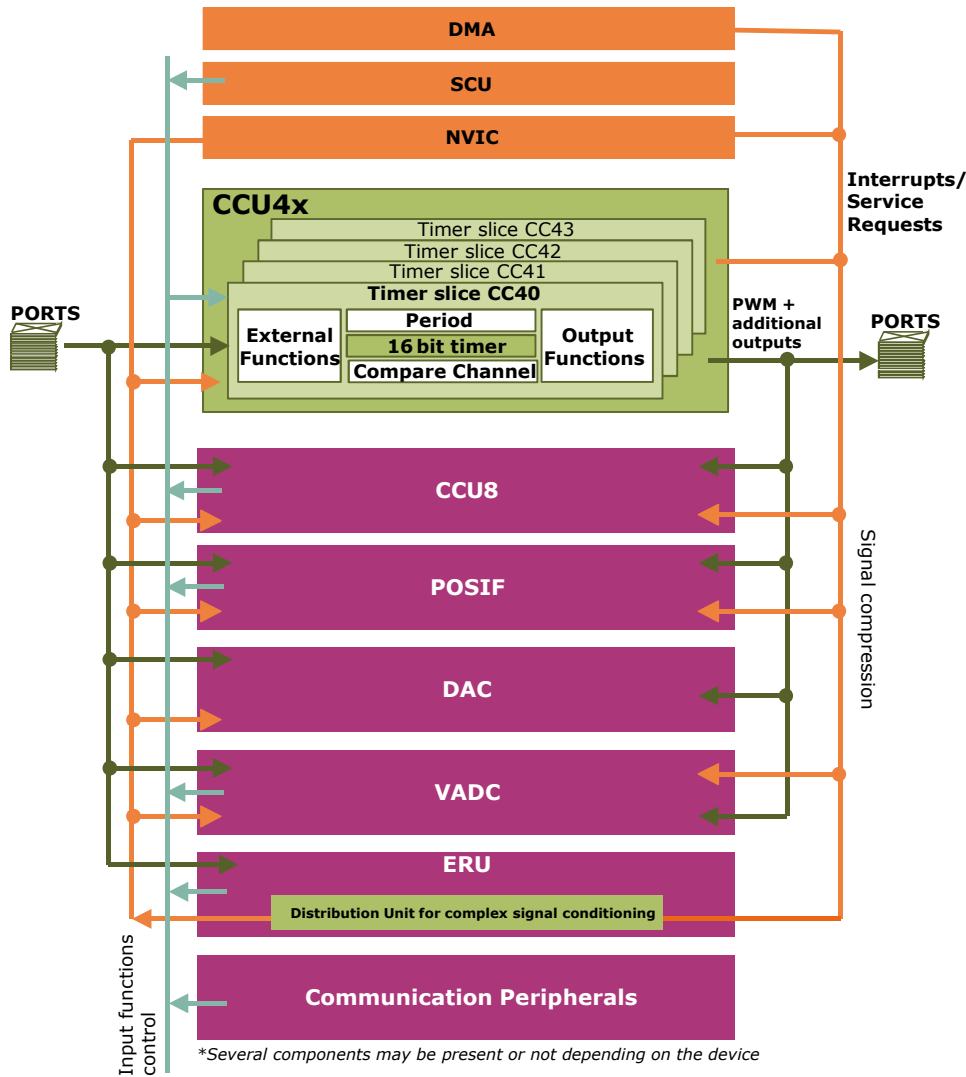

XMC4100	XMC4200	XMC4400	XMC4500	XMC4700
•	•	•	•	•

XMC1100	XMC1200	XMC1300	
•	•	•	

The CCU4 system integration offers several advantages:

- › Distribution bus over the ERU for complex signal conditioning application cases
- › Usage of interrupts/service requests as flexible connection for ADC conversion triggering (signal compression)
- › Synchronous control over several Timers via the SCU
- › The CCU4 is agnostic to the type of signal (feature and type: level, edge)
- › Target applications:
  - Motor control
  - Power conversion
  - Human machine interface
  - Connectivity
  - General purpose

# Agenda

- 1 Overview
- 2 Key feature: Modular timer approach with repeated external functions
- 3 Key feature: Flexible PWM generation
- 4 Key feature: Flexible capture scheme
- 5 System integration
- 6 Application example

# Application example

## PWM for generic purpose (1/2)

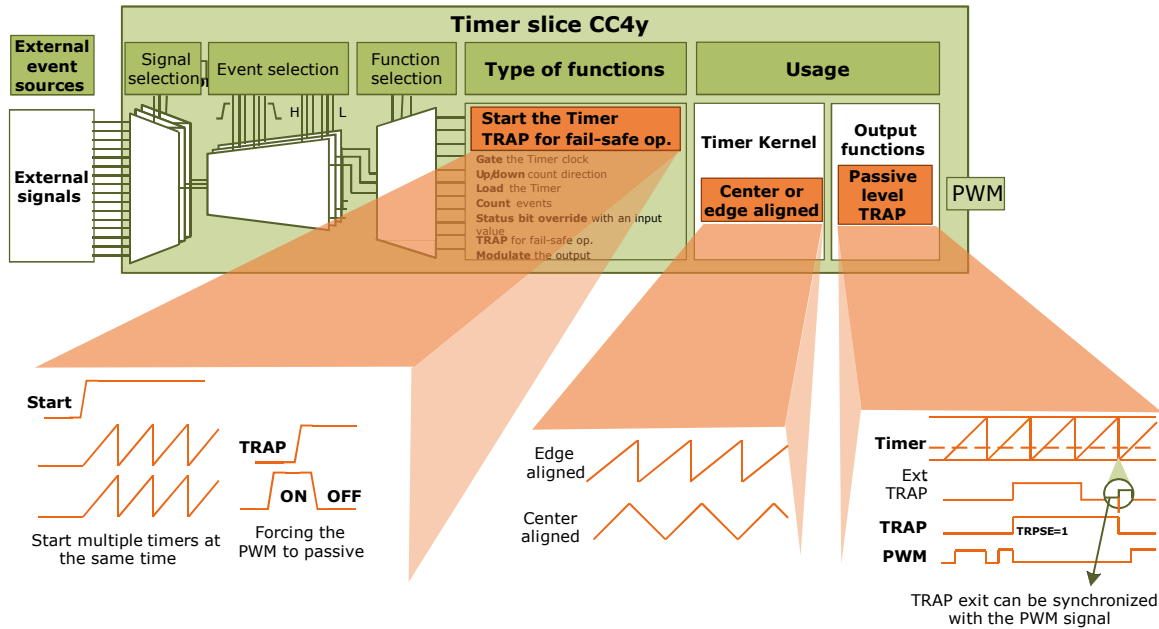

## Overview

For a standard PWM generation application, three major functions can be controlled in each CCU4 timer slice:

- › Start PWM generation
- › Type of counting scheme (edge or center aligned)
- › Passive Level of the PWM

The start of the PWM can be applied to any combination of timers.

Additionally, a TRAP signal can be configured to set the PWM in a pre-configured passive state.

## In brief

Standard functions for generic PWM generation

# Application example

## PWM for generic purpose (2/2)

- › For the two available counting schemes: edge and center aligned, the duty cycle and period values can be updated on-the-fly
- › Additionally, a passive level dictates where the PWM signal turns OFF. The passive level can be updated also on-the-fly
- › In center aligned mode, it is possible to generate an asymmetric PWM signal. The SW can update the Compare Register (CR) in two different instants, which means that the rising edge may not be aligned with the falling edge

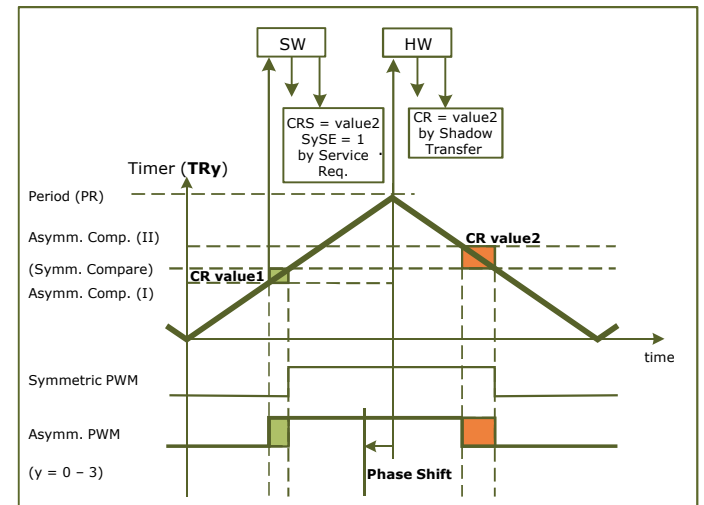
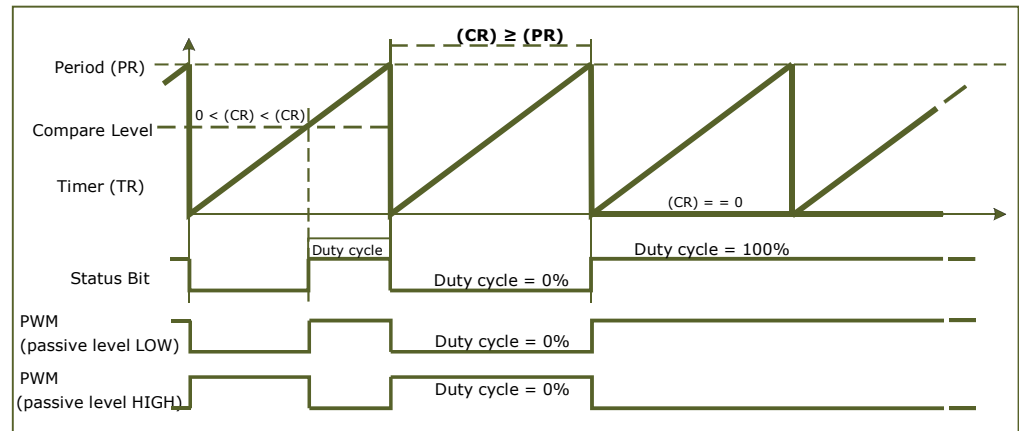

Application example – PWM generation: Detailed timing diagram



# Application example

## PWM for power conversion (1/2)

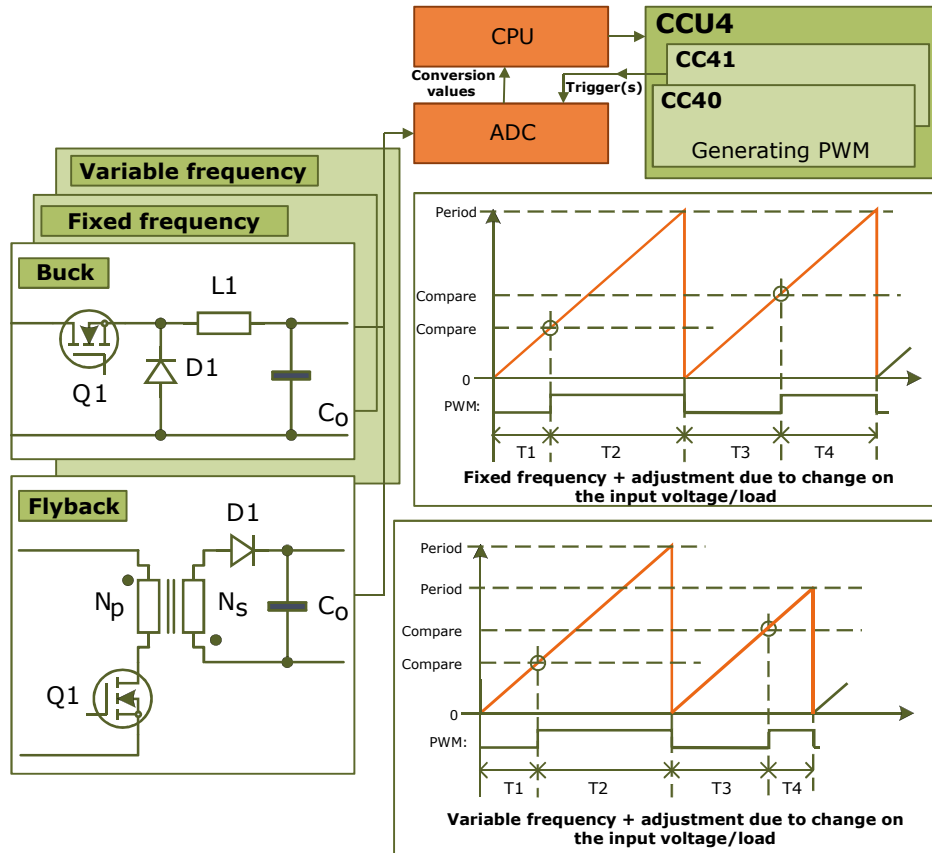

## Overview

Inside the power conversion application domain, one has different type of topologies that may request different type of control methods.

With each CCU4 timer slice it is possible to implement all the needed requirements, such as: variable duty cycle, variable switching frequency and a combination of both.

The flexible connections between the CCU4 and additional modules, e.g. ADC, will simplify the task of controlling and generating conversion triggers for each application.

## In brief

Controlling different types of single phase power converter topologies

# Application example

## PWM for power conversion (2/2)

With the extra functions controllable by external signal, it is possible to easily implement a PFC stage.

The CC40 slice is used for noise suppression.

The CC41 slice is used for PWM generation with fixed ON time.

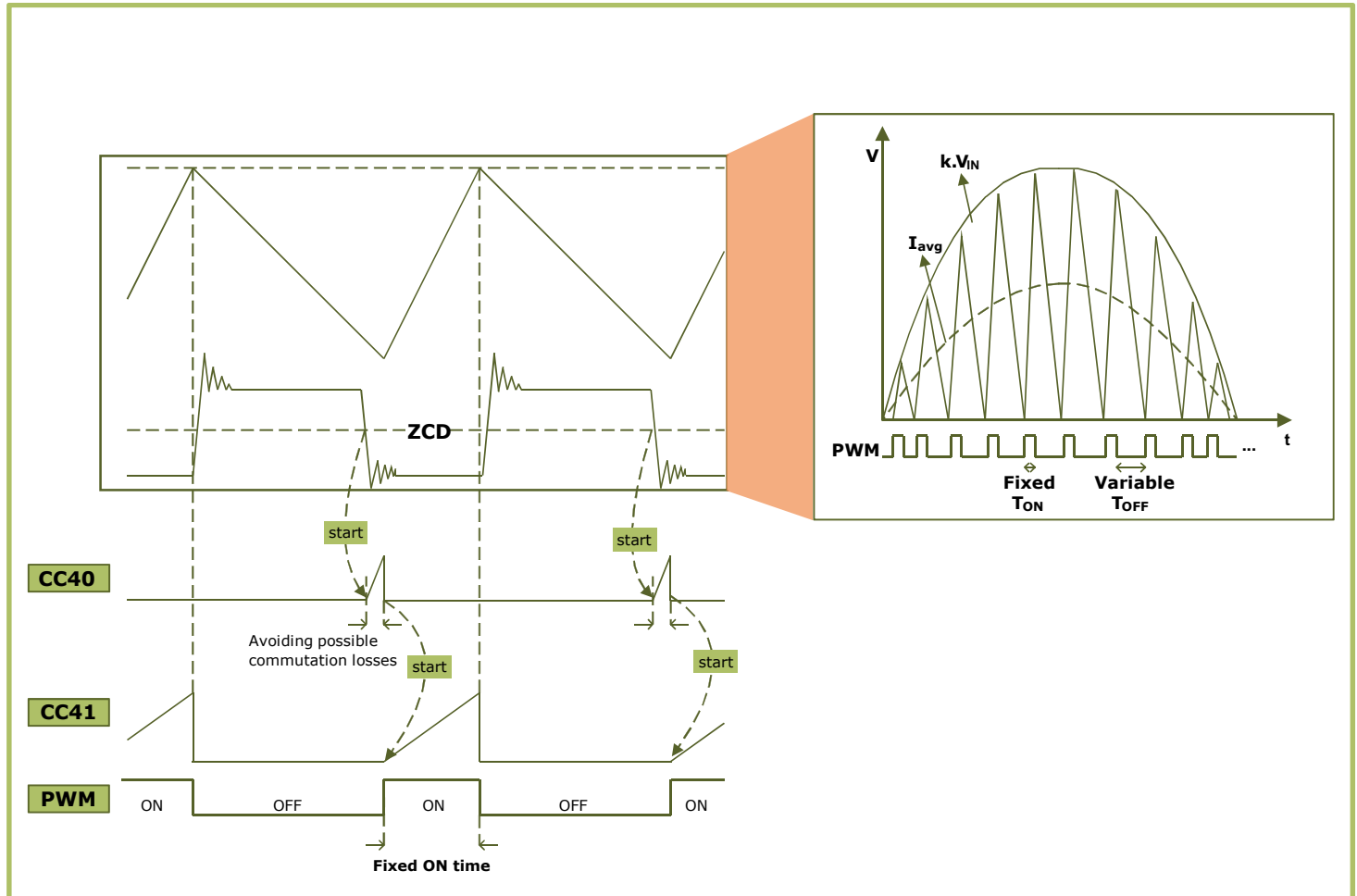

Application example – PFC in Critical Conduction Mode: Detailed timing diagram

# Application example

## Sampling control with noise rejection (1/2)

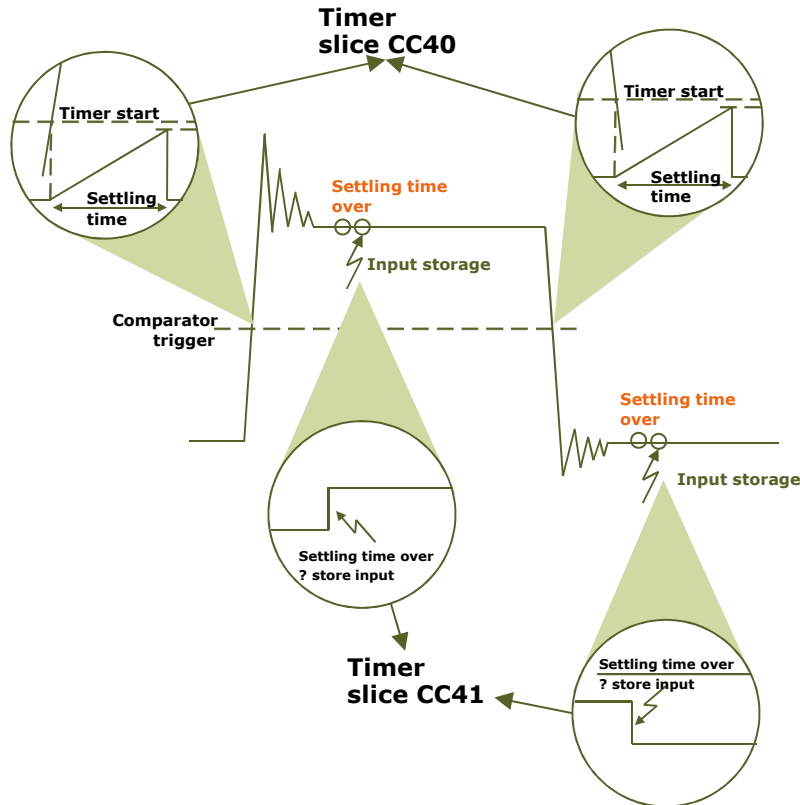

### In brief

- › Storage of an external signal level after noise suppression

### Overview

A lot of signal conditioning application cases involve not only noise rejection but also sampling control.

Noise rejection is normally needed when the sampled signal comes from a noisy environment. Sampling control can impose several requirements, e.g. ADC periodic triggers, controllable number of conversions, etc.

CCU4 modularity and huge set of external functions, provide a huge flexibility for this type of signal conditioning.

# Application example

## Sampling control with noise rejection (2/2)

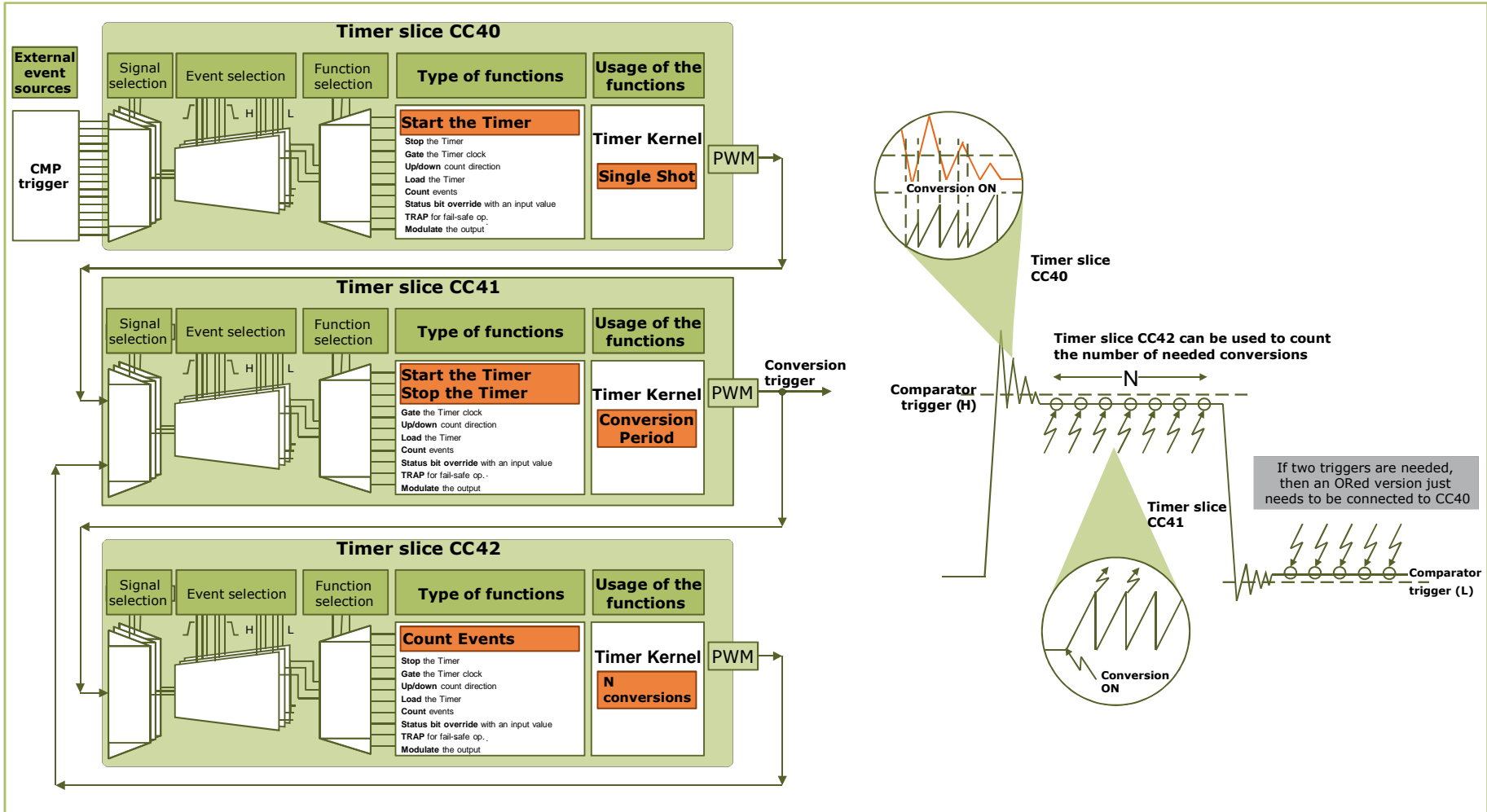

Application example – noise rejection + ADC conversion: Block diagram

# Application example

## Capture control with high dynamics (1/2)

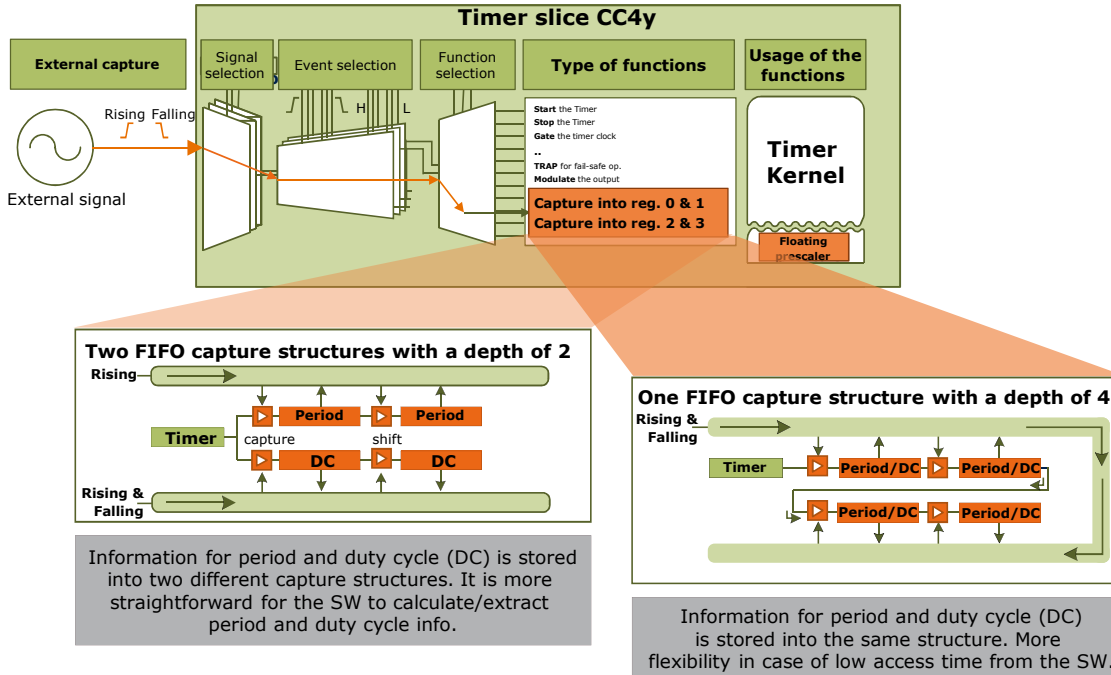

## Overview

A common signal monitoring function expected from a timer module, is the extraction/storage of the period and duty cycle information.

Each timer slice can capture the current value of the timer into a register structure in any type of edge configuration (rising, falling or both).

This register structure can then be read back by SW from a single address that returns the oldest captured value.

The timer can also be cleared every time that a capture occurs.

## In brief

- › Capturing the period and duty cycle of an external signal

# Application example

## Capture control with high dynamics (2/2)

If the Input capture trigger(s) frequency is unknown (or has very large frequency spectrum), the timer slice can use the Floating Prescaler to automatically adjust the clock frequency to the input trigger time stamp.

This will end up in a reduced interrupt/SW activity (no need to have an interrupt in each timer rollover).

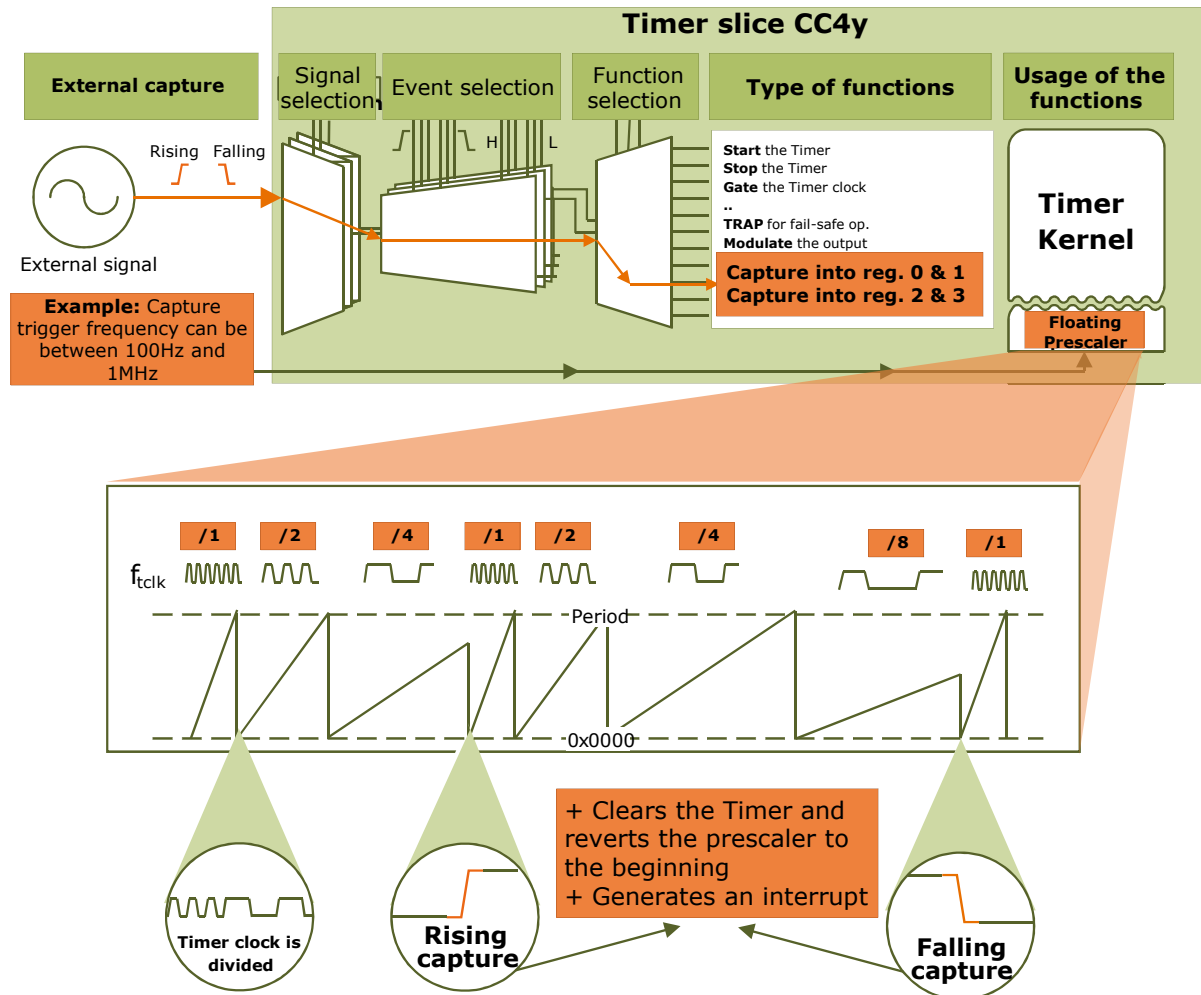

Application example – Unknown frequency capture: Timing diagram

# Application example

## Signal compression with service requests (1/2)

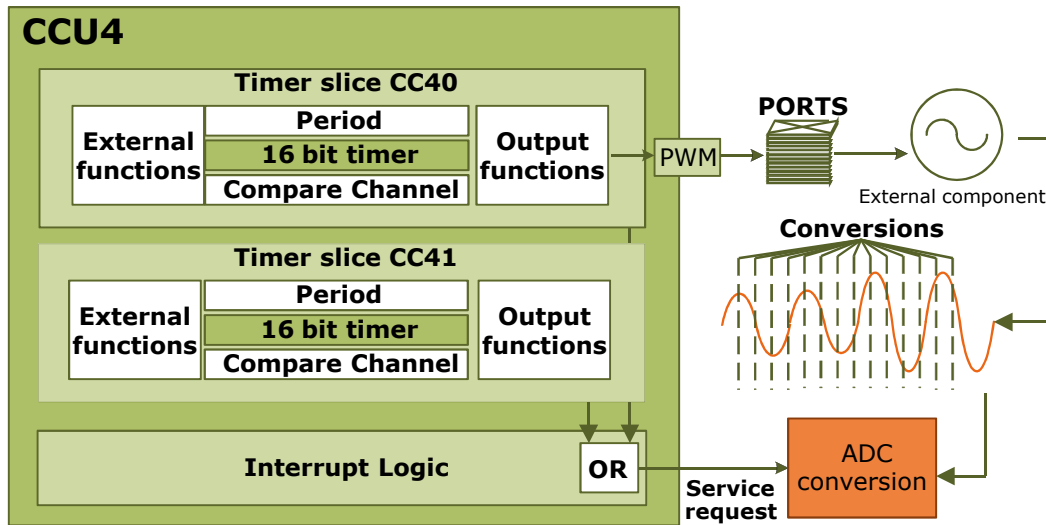

## Overview

In some applications it may be necessary to generate several ADC conversion triggers synchronized with a PWM signal.

Additionally, a delayed conversion trigger may also be needed for averaging or noise estimation.

The CCU4 interrupt logic, give the flexibility to group several triggers into just one service request line.

This not only optimizes the connectivity inside the microcontroller but also offers a better resource usage density.

## In brief

- › Using service requests to compress ADC triggers

# Application example

## Signal compression with service requests (2/2)

In the previous slide, we can see that both timer slices are generating conversion triggers for the ADC.

The CC40 is also generating a PWM signal that is controlling an external component.

While the CC40 is generating a conversion trigger every time that an update on the PWM is done, the CC41 is generating a delayed conversion trigger (that can be kept even when CC40 is at 0% or 100%).

This triggers are grouped into just one service request connection.

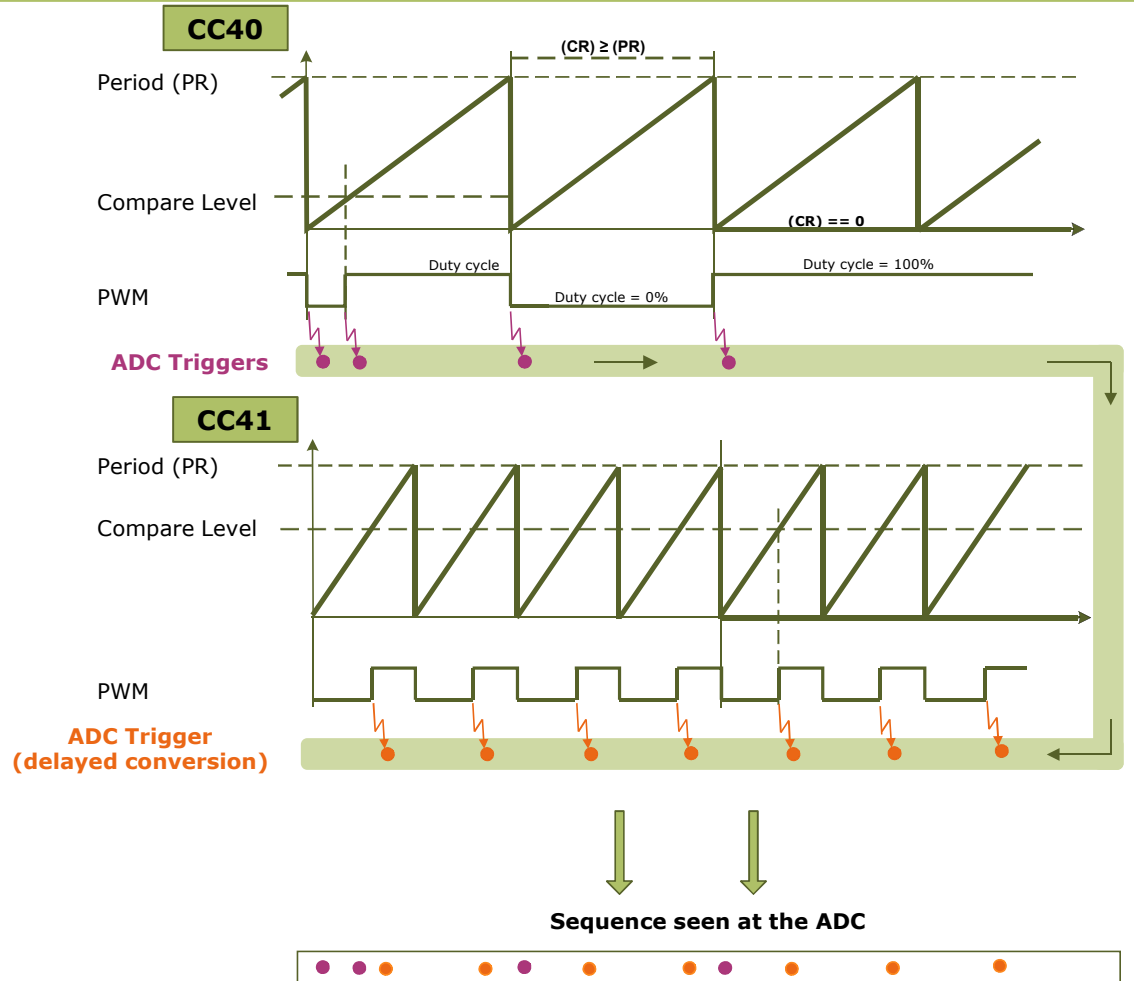

Application example – Grouped conversion triggers: Timing diagram



# Support material

## Collaterals and Brochures

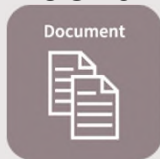

- › Product Briefs
- › Selection Guides
- › Application Brochures
- › Presentations
- › Press Releases, Ads

› [www.infineon.com/XMC](http://www.infineon.com/XMC)

## Technical Material



- › Application Notes
- › Technical Articles
- › Simulation Models
- › Datasheets, MCDS Files
- › PCB Design Data

› [www.infineon.com/XMC](http://www.infineon.com/XMC)

› [Kits and Boards](#)

› [DAVE™](#)

› [Software and Tool Ecosystem](#)

## Videos



- › Technical Videos
- › Product Information Videos

› [Infineon Media Center](#)

› [XMC Mediathek](#)

## Contact



- › Forums
- › Product Support

› [Infineon Forums](#)

› [Technical Assistance Center \(TAC\)](#)

# Disclaimer

The information given in this training materials is given as a hint for the implementation of the Infineon Technologies component only and shall not be regarded as any description or warranty of a certain functionality, condition or quality of the Infineon Technologies component.

Infineon Technologies hereby disclaims any and all warranties and liabilities of any kind (including without limitation warranties of non-infringement of intellectual property rights of any third party) with respect to any and all information given in this training material.



Part of your life. Part of tomorrow.

