

## AEC-Q103 qualified high performance digital XENSIV™ MEMS microphone

### Features

- Automotive qualification
- Flat frequency response down to 7 Hz for best ANC performance
- Close sensitivity and phase matching for optimum beam forming
- Extended availability to match automotive design cycles
- Digital PDM output
- Active THD compensation to reduce distortions at high SPL levels
- Small 3.5 x 2.65 x 0.98mm<sup>3</sup> surface-mount package



### Potential applications

- Active noise cancellation / Road noise cancellation (ANC/RNC)
- Hands free calling / Voice control
- Emergency call
- Siren detection
- Road condition detection

### Product validation

Qualified for automotive applications. Product validation according to AEC-Q103-003.

### Description

The device is designed for applications where low self-noise (high SNR), wide dynamic range, low distortions and a high acoustic overload point are required. The low cut-off frequency (LFRO) makes it a well suited device for active noise cancelling (ANC) applications.

Infineon's MEMS technology is based on a miniaturized microphone design and results in high linearity of the output signal within a high dynamic range. With its low equivalent noise floor the microphone is no longer the limiting factor in the audio signal chain and enables higher performance of voice recognition algorithms.

The digital microphone ASIC contains a microphone specific THD compensation algorithm for optimal performance at high sound pressure levels (SPL), an extremely low-noise preamplifier and a high-performance sigma-delta analog-to-digital converter (ADC). The tight manufacturing tolerance, combined with the fact that each device is calibrated with an advanced Infineon calibration algorithm, results in small sensitivity and phase matching tolerances. This makes it well suited for beam forming arrays and multi-microphone applications.

**Table 1** Product summary

Parameter	Value	Customer benefit
SNR	66 dB(A)	Improved speech quality and higher speech intelligibility
THD 1%	114 dB SPL	Clear speech up to high SPL levels
AOP (THD 10%)	120 dB SPL	Optimized dynamic range for 16-bit audio codecs
LFRO	7 Hz	Flat frequency response for best ANC performance
T <sub>A</sub>	-40°C ... +105°C	Flexible placement inside and outside the car

**Table 2** Order information

Product name	Package	Marking	Ordering code
IM66D120A	PG-TLGA-5-6	IA66D2	SP005926392

## Table of contents

	<b>Table of contents</b> .....	2
<b>1</b>	<b>Block diagram</b> .....	3
<b>2</b>	<b>Pin configuration</b> .....	4
<b>3</b>	<b>General product characteristics</b> .....	5
3.1	Electrical parameters and characteristics .....	5
3.1.1	Absolute maximum ratings .....	5
3.1.2	Functional range .....	5
<b>4</b>	<b>Product features</b> .....	7
4.1	Electrical characteristics .....	7
4.1.1	Timing diagram .....	8
4.2	Acoustic characteristics .....	8
4.2.1	Free field frequency response .....	10
4.3	Typical performance characteristics .....	11
<b>5</b>	<b>Application information</b> .....	12
5.1	Use cases .....	12
5.2	Typical application circuit .....	13
<b>6</b>	<b>Package information</b> .....	14
6.1	Package outline .....	14
6.2	Footprint and stencil recommendation .....	15
6.3	Reflow soldering and board assembly .....	16
6.4	Packing .....	17
<b>7</b>	<b>Reliability specifications</b> .....	18
<b>8</b>	<b>Revision history</b> .....	20
	<b>Disclaimer</b> .....	21

## 1 Block diagram

The device contains two different dies combined inside one package.

The MEMS picks up the sound waves and converts them into an electrical signal. The ASIC contains all needed circuitry for biasing the MEMS and amplifying the MEMS signal to a stable and calibrated microphone output.

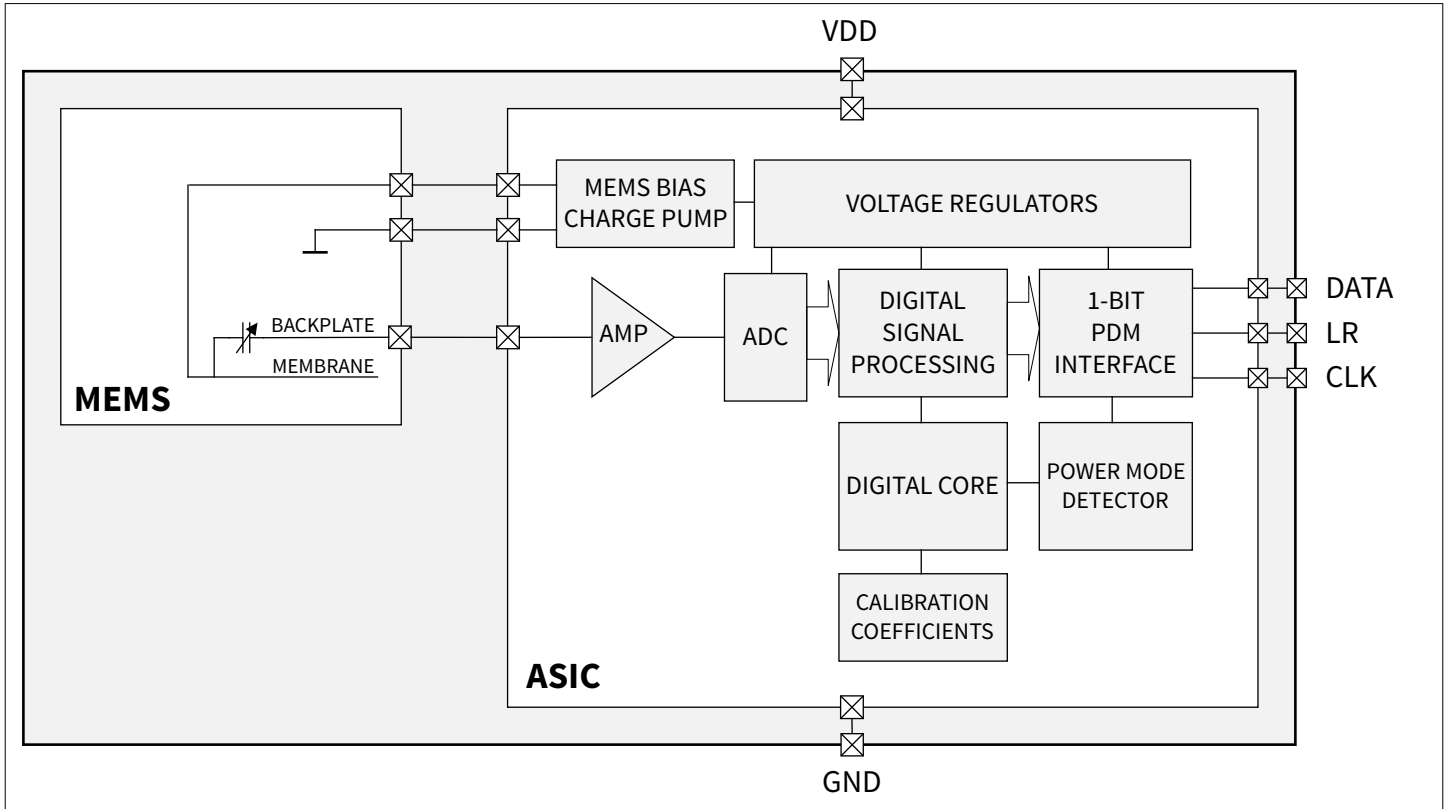

**Figure 1** Block diagram

## 2 Pin configuration

The figure below shows the pin configuration of the device

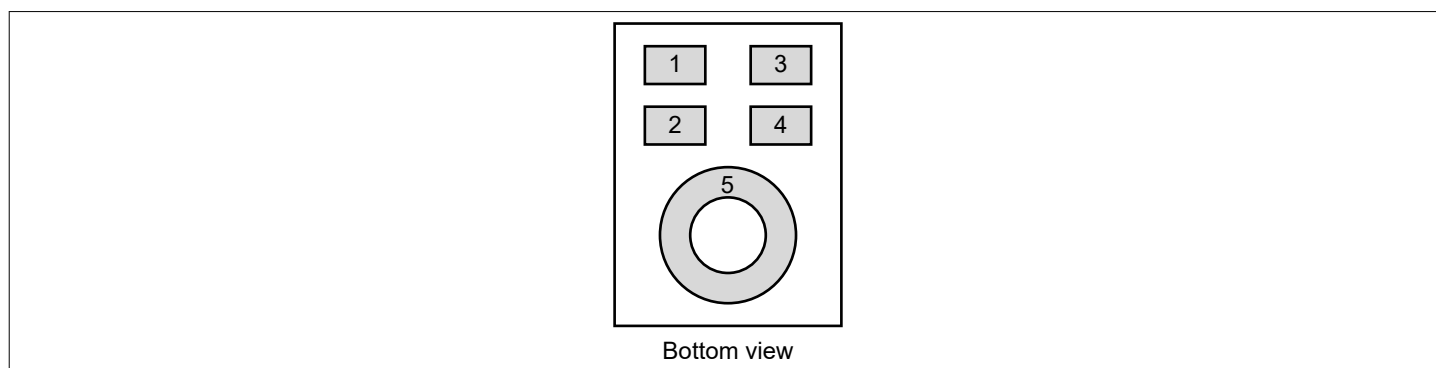

**Figure 2** Pin configuration

**Table 3** Pin configuration

Pin number	Name	Description
1	VDD	Power supply
2	CLK	PDM clock input
3	DATA	PDM data output
4	LR	PDM left/right select
5	GND	Ground

### 3 General product characteristics

#### 3.1 Electrical parameters and characteristics

##### 3.1.1 Absolute maximum ratings

Table 4 Absolute maximum ratings

Parameter	Symbol	Values			Unit	Note or condition
		Min.	Typ.	Max.		
Storage temperature	$T_S$	-40	–	125	°C	
Supply voltage	$V_{DD}$	-0.3	–	4.0	V	
ESD robustness all pins (HBM)	$V_{ESD\_HBM}$	-2	–	2	kV	according EIA/JESD22/A114

**Attention:** Stresses above those listed under “Absolute maximum ratings” may cause permanent damage to the device. This is a stress rating only and functional operation of the device at these or any other conditions above those indicated in the section "Functional range" of this datasheet is not implied. Furthermore, only single error cases are assumed. More than one stress/error case may also damage the device.

Exposure to absolute maximum rating conditions for extended periods may affect device reliability. During absolute maximum rating overload conditions the voltage on VDD pins with respect to ground (GND) must not exceed the values defined by the absolute maximum ratings.

Lifetime statements are an anticipation based on an extrapolation of Infineon’s qualification test results. The actual lifetime of a component depends on its form of application and type of use etc. and may deviate from such statement. Lifetime statements shall in no event extend the agreed warranty period.

##### 3.1.2 Functional range

The following functional range shall not be exceeded in order to ensure correct operation of the device. All parameters specified in the following sections refer to these operating conditions unless otherwise indicated.

Table 5 Functional range

Parameter	Symbol	Values			Unit	Note or condition
		Min.	Typ.	Max.		
Supply voltage	$V_{DD}$	1.62	1.8	3.6	V	A 100nF bypass capacitor should be placed close to the microphone's VDD pin to ensure best SNR performance
Ambient operating temperature	$T_A$	-40	–	+105	°C	
VDD ramp-up Time	$V_{DD\_ru}$	0.01	–	10	ms	Time until $V_{DD} \geq V_{DD\_min}$
Clock Frequency Range - HPM	$f_{CLK\_HPM}$	1.2	3.072	3.2	MHz	

(table continues...)

**Table 5** (continued) **Functional range**

Parameter	Symbol	Values			Unit	Note or condition
		Min.	Typ.	Max.		
Clock Frequency Range - Standby mode	$f_{CLK\_sb}$	–	–	320	kHz	DATA = high-Z
PDM Clock Frequency	$f_{CLK}$	0.45	–	3.2	MHz	
Clock Duty Cycle	$CLK_{duty}$	45	–	55	%	
Clock Rise/Fall Time	$t_{CR} / t_{CF}$	–	–	13	ns	
Input Logic Low Level	$V_{IL}$	-0.3	–	$0.28 \times V_{DD}$	V	
Input Logic High Level	$V_{IH}$	$0.65 \times V_{DD}$	–	$V_{DD} + 0.3$	V	
Hysteresis	$V_{hys}$	0.08	–	–	V	
Output Load Capacitance on DATA	$C_{load}$	–	–	200	pF	

## 4 Product features

### 4.1 Electrical characteristics

The values in the table "Electrical characteristics" are valid under the following conditions (unless otherwise specified in the table):  $V_{DD} = 1.8V \pm 0.1V$ ,  $T_A = 25^\circ C \pm 5^\circ C$

**Table 6** Electrical characteristics

Parameter	Symbol	Values			Unit	Note or condition
		Min.	Typ.	Max.		
Current Consumption - HPM	$I_{DD\_HPM}$	–	1100	1400	$\mu A$	No load on DATA
Current Consumption - Standby mode	$I_{standby}$	–	1	5	$\mu A$	No load on DATA; CLK pulled to GND
Short Circuit Current	$I_{short}$	1	–	20	mA	Grounded DATA pin
Power Supply Rejection - Sine	$PSR_{1k\_NM}$	–	-84	–	dBFS	100mV <sub>pp</sub> sine wave on $V_{DD}$ swept from 200Hz to 20kHz
Power Supply Rejection - Square	$PSR_{217\_NM}$	–	-84	–	dBFS(A)	100mV <sub>rms</sub> , 217Hz square wave on $V_{DD}$ , A-weighted
Startup Time, $\pm 0.5$ dB sensitivity accuracy	$t_{start-up}$	–	–	20	ms	Time to start up in all operating modes after $V_{DD\_min}$ and CLOCK have been applied
Startup Time, $\pm 0.2$ dB sensitivity accuracy	$t_{start-up\_HP}$	–	–	50	ms	Time to start up in all operating modes after $V_{DD\_min}$ and CLOCK have been applied
Mode Switch Time, $\pm 0.5$ dB sensitivity accuracy	$t_{mode-switch}$	–	–	20	ms	Time to switch between operating modes. $V_{DD}$ remains on during the mode switch
Mode Switch Time, $\pm 0.2$ dB sensitivity accuracy	$t_{mode-switch\_HP}$	–	–	50	ms	Time to switch between operating modes. $V_{DD}$ remains on during the mode switch
Output Logic Low Level	$V_{OL}$	–	–	$0.3 \times V_{DD}$	V	$I_{out} \leq 2mA$
Output Logic High Level	$V_{OH}$	$0.7 \times V_{DD}$	–	–	V	$I_{out} \leq 2mA$
Delay Time for DATA Driven	$t_{DD}$	28	–	–	ns	Delay time from CLOCK edge ( $0.5 \times V_{DD}$ ) to DATA driven
Delay Time for DATA High-Z	$t_{HZ}$	14	–	26	ns	Delay time from CLOCK edge ( $0.5 \times V_{DD}$ ) to DATA high impedance state <sup>1)</sup>
Delay Time for DATA Valid	$t_{DV}$	–	–	100	ns	Delay time from CLOCK edge ( $0.5 \times V_{DD}$ ) to DATA valid ( $< 0.3 \times V_{DD}$ or $> 0.7 \times V_{DD}$ ) <sup>2)</sup>

1)  $t_{HZ}$  is dependent upon  $C_{load}$

2) Load on DATA:  $C_{load} = 50\text{pF}$ ,  $R_{load} = 100\text{k}\Omega$

### 4.1.1 Timing diagram

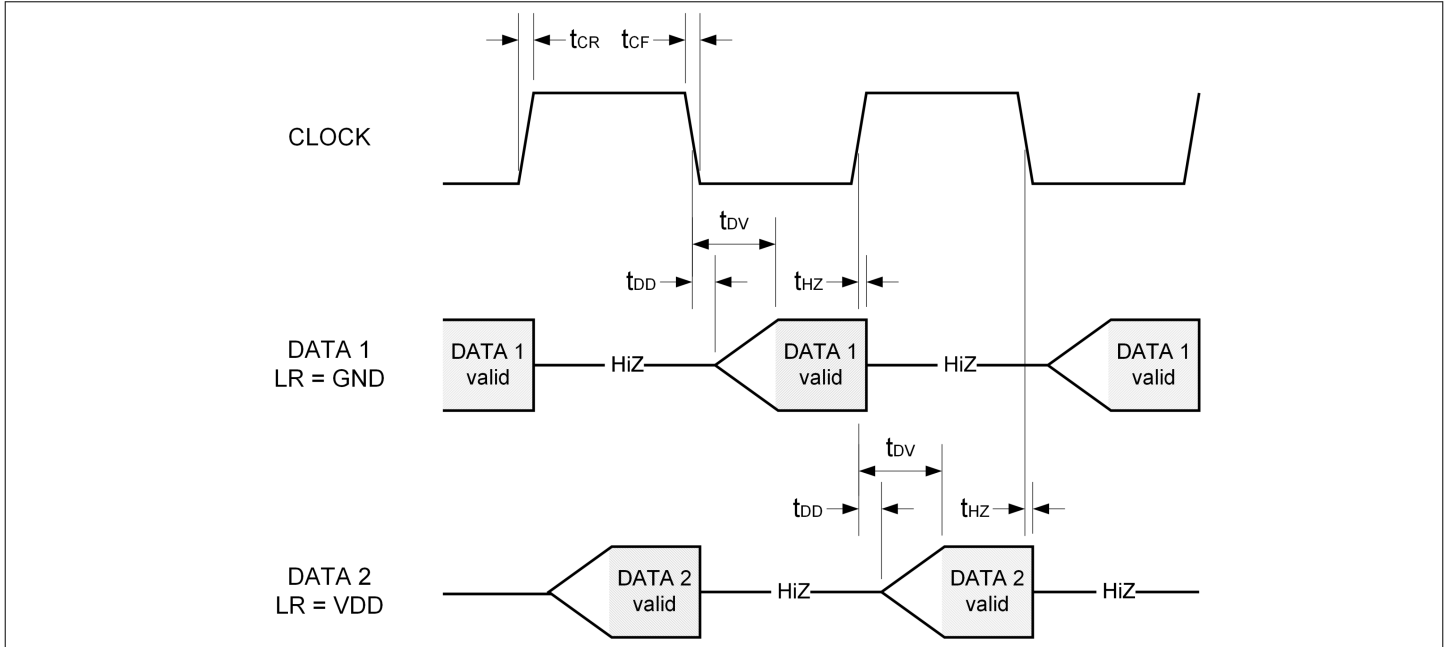

**Figure 3** Timing diagram

## 4.2 Acoustic characteristics

The values in the table "Acoustic characteristics" are valid under the following conditions (unless otherwise specified in the table):  $V_{DD} = 1.8\text{V} \pm 0.1\text{V}$ ,  $T_A = 25^\circ\text{C} \pm 5^\circ\text{C}$ , audio bandwidth 20Hz to 20kHz, output unloaded

The acoustic performance is dependant on the CLK frequency. All values in the table below are given for the typical CLK frequency of the mode.

**Table 7** Acoustic characteristics

Parameter	Symbol	Values			Unit	Note or condition
		Min.	Typ.	Max.		

#### High performance mode (HPM)

Sensitivity	$Sens_{HPM}$	-27	-26	-25	dBFS	1kHz, 94 dB SPL
Signal to noise ratio	$SNR_{HPM}$	-	66	-	dB(A)	A-Weighted
Equivalent input noise	$EIN_{HPM}$	-	28	-	dB SPL	A-Weighted
Total harmonic distortion, 94dB SPL	$THD_{94\_HPM}$	-	0.1	-	%	Measuring 2nd to 5th harmonics; 1kHz
Total harmonic distortion, 1%	$THD_{1\%\_HPM}$	-	114	-	dB SPL	Measuring 2nd to 5th harmonics; 1kHz
Acoustic overload point (10% THD)	$AOP_{HPM}$	-	120	-	dB SPL	Measuring 2nd to 5th harmonics; 1kHz

**(table continues...)**



**Table 7 (continued) Acoustic characteristics**

Parameter	Symbol	Values			Unit	Note or condition
		Min.	Typ.	Max.		
<b>All power modes</b>						
Low frequency roll-off point	$LFRO$	-	7	-	Hz	-3dB point relative to 1kHz
Phase response, 75Hz	$\Phi_{75}$	-	7	-	°	
Phase response, 1kHz	$\Phi_{1000}$	-	-4	-	°	
Phase response, 3kHz	$\Phi_{3000}$	-	-13	-	°	
Group delay, 250Hz	$t_{gd\_250}$	-	38	-	μs	
Group delay, 600Hz	$t_{gd\_600}$	-	17	-	μs	
Group delay, 1kHz	$t_{gd\_1000}$	-	14	-	μs	
Group delay, 4kHz	$t_{gd\_4000}$	-	13	-	μs	

**Polarity:** The device has a positive polarity. Positive pressure increases density of 1's, negative pressure decreases density of 1's in data output.

**Directivity:** The device has an omnidirectional pickup pattern.

### 4.2.1 Free field frequency response

The figure below shows the typical free field response of the device.

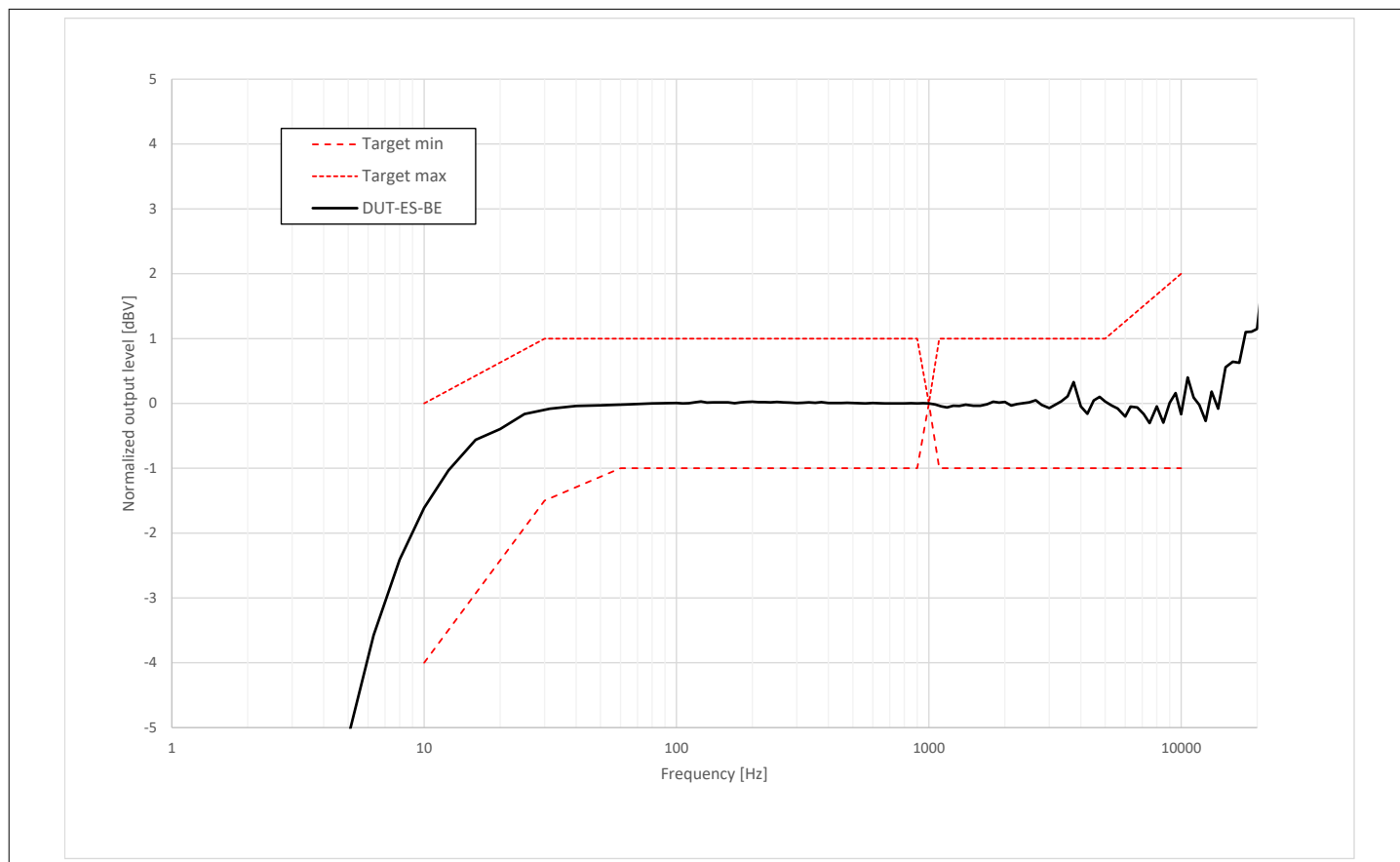

**Figure 4** Free field frequency response

**Table 8** Free field frequency response, normalized to 1kHz sensitivity value

Frequency (Hz)	Lower limit (dB)	Upper limit (dB)
10	-4	0
30	-1.5	1
60	-1	1
100	-1	+1
1000	0	0
5000	-1	+1
10000	-1	+2

### 4.3 Typical performance characteristics

Conditions:  $V_{DD} = 1.8V \pm 0.1V$ ,  $T_A = 25^\circ C \pm 5^\circ C$ ,  $f_{CLK} = 3.072MHz$ , output unloaded

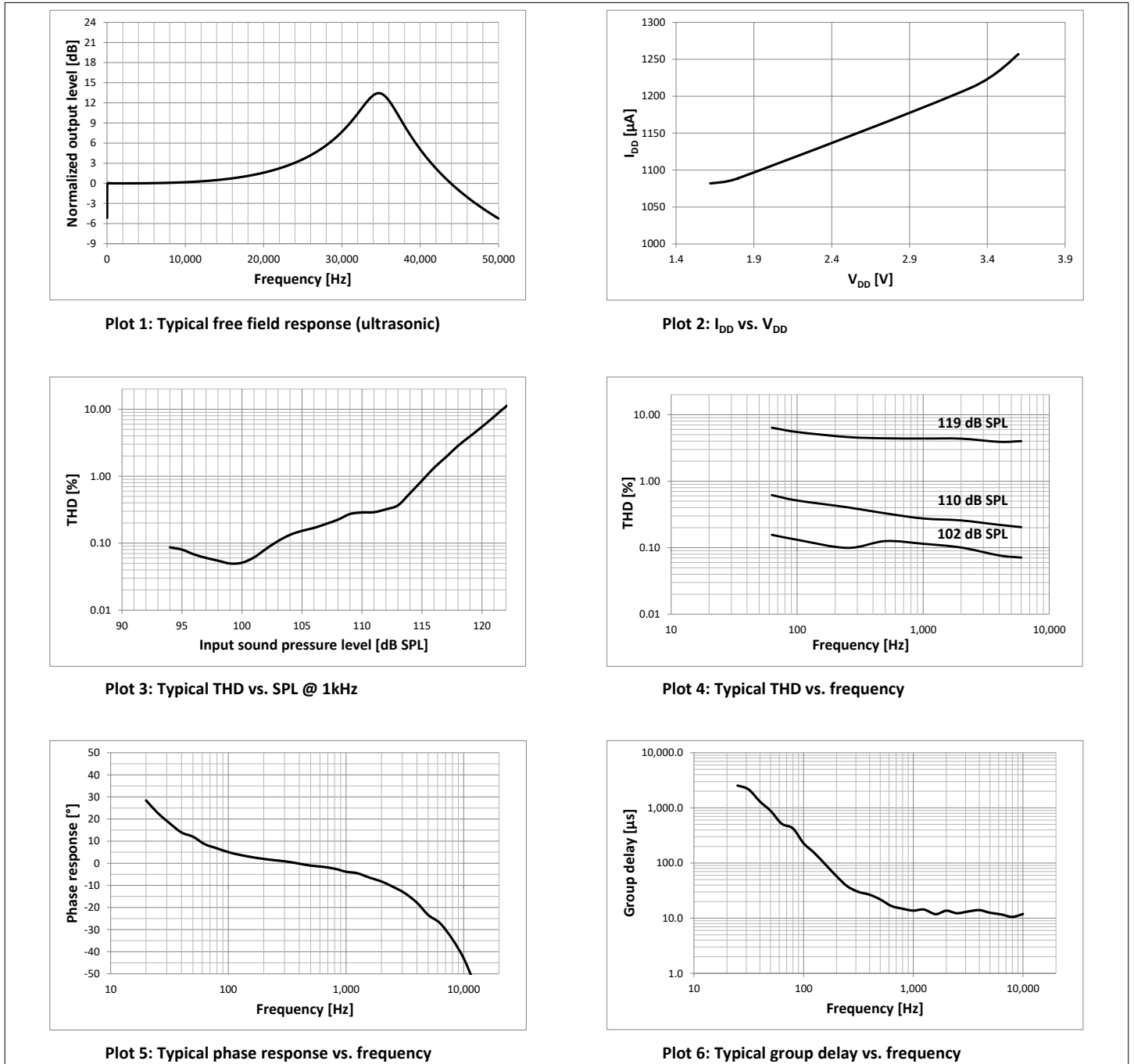

Figure 5 Typical performance characteristics

## 5 Application information

*Note: The following information is given as an example for the implementation of the device only and shall not be regarded as a description or warranty of a certain functionality, condition or quality of the device.*

### 5.1 Use cases

- Flat frequency response with very low LFRO (low frequency roll off point) and small group delay
  - Best performance for active noise cancellation systems (ANC, RNC, ...)
  - Excellent speech quality over full frequency range
- Total harmonic distortion (THD) up to high sound pressure levels (SPL)
  - Clear speech in a wide dynamic range
  - Reliable voice commands even with high background noise
  - Improved ANC system performance in loud environments
- High acoustic overload point (AOP)
  - Distortion less output signal even in loud environments
- High signal to noise ratio (SNR)
  - Far field audio signal pick-up
  - Low volume audio and whispered voice capturing
  - Good performance with speech recognition algorithms
  - Microphone noise is no longer limiting the audio chain
- Close sensitivity and phase matching
  - Good performance in audio beamforming
  - High and precise attenuation of background noise
  - Full utilization of voice algorithms capability

## 5.2 Typical application circuit

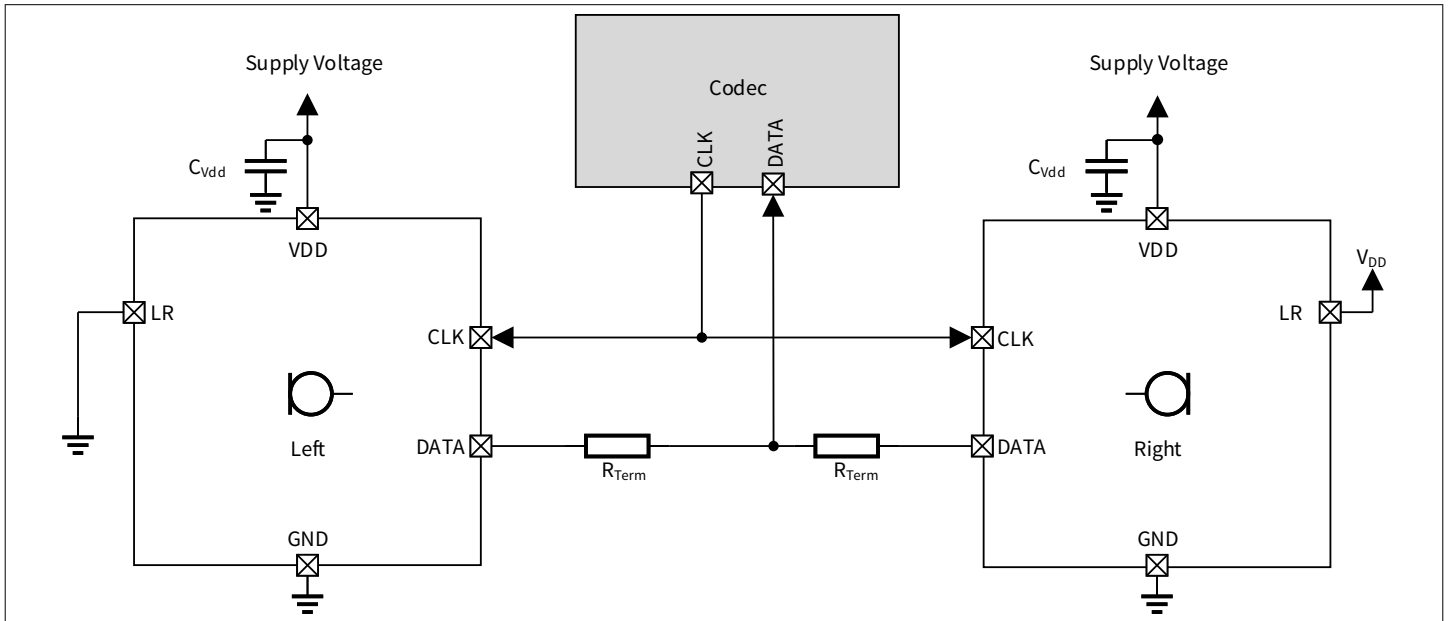

**Figure 6** Typical application circuit

*Note:* For best performance it is strongly recommended to place a 100nF ( $C_{VDD\_typical}$ ) capacitor between VDD and ground. The capacitor should be placed as close to VDD as possible. A termination resistor ( $R_{TERM}$ ) of about 100Ω may be added to reduce the ringing and overshoot on the output signal.

*Note:* This figure is a simplified example of an application circuit. The function must be verified in the application.

## 6 Package information

This product is compliant to RoHS

### 6.1 Package outline

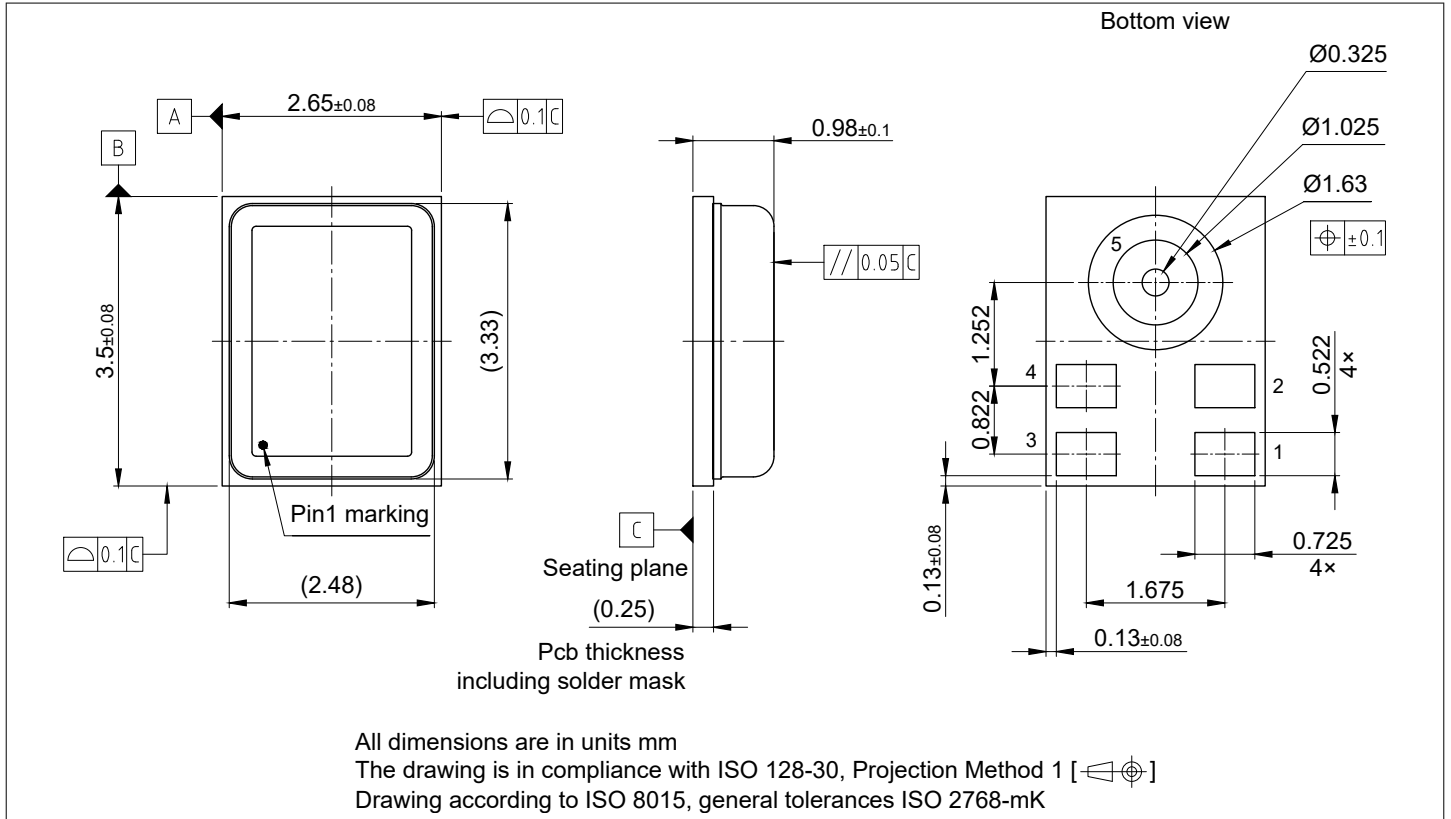
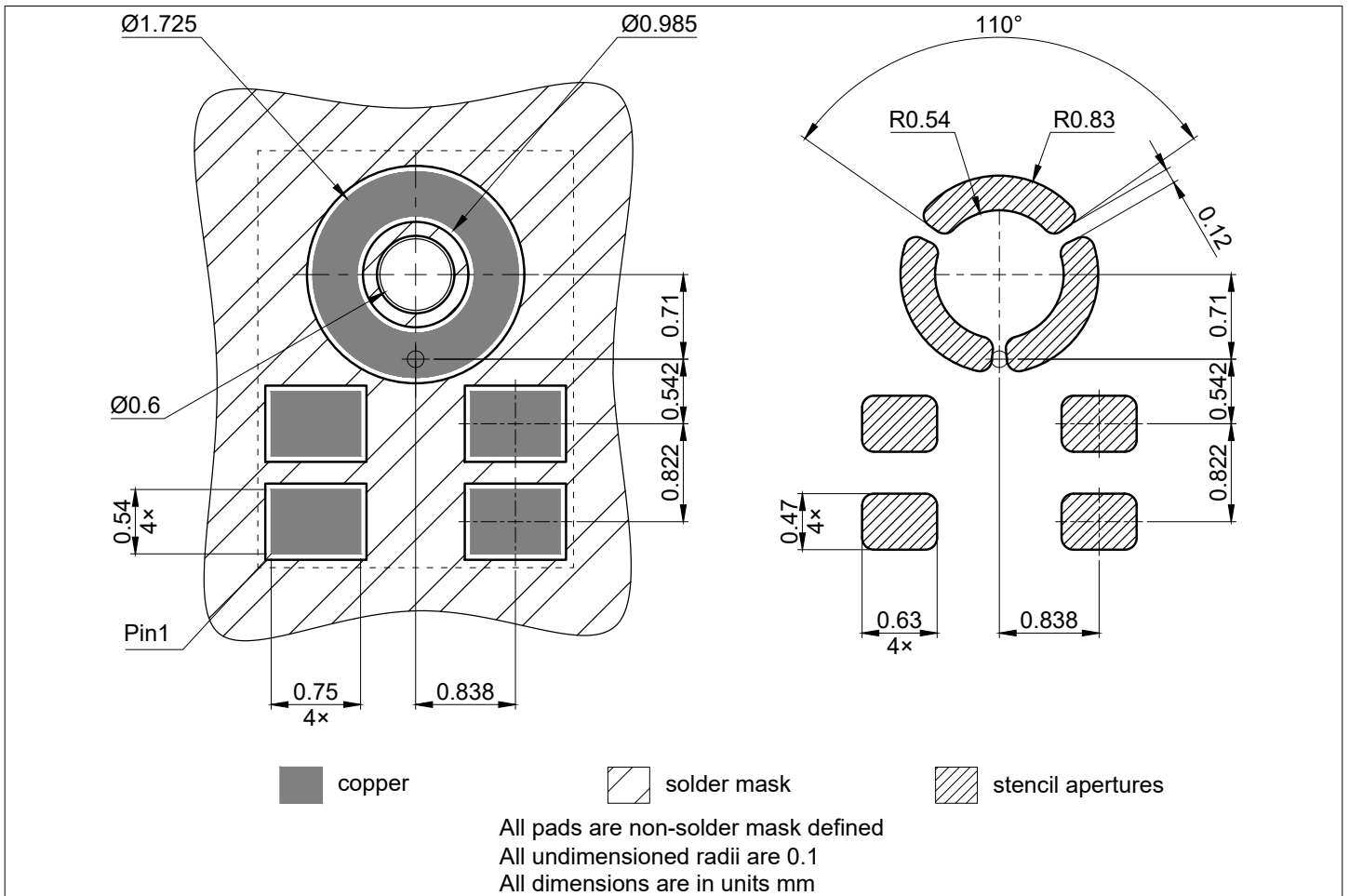

Figure 7 Package outline drawing

## 6.2 Footprint and stencil recommendation

The acoustic port hole diameter in the PCB should be larger than the acoustic port hole diameter of the MEMS microphone to ensure optimal performance. A PCB sound port size of radius 0.3 mm (diameter 0.6mm) is recommended.

The board pad and stencil aperture recommendations shown in the figure below are based on solder mask defined (SMD) pads. The specific design rules of the board manufacturer should be considered for individual design optimizations or adaptations.

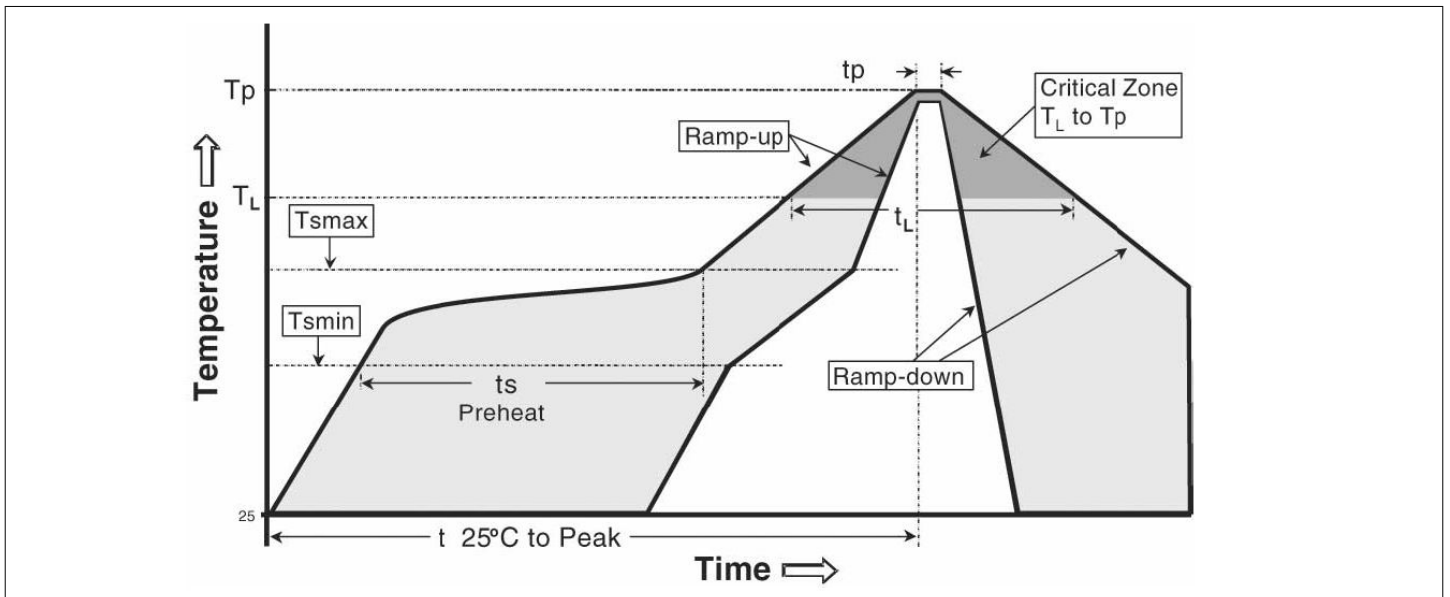

**Figure 8** Foot print and stencil recommendation

### 6.3 Reflow soldering and board assembly

Infineon MEMS microphones are qualified in accordance with the IPC/JEDEC J-STD-020D-01. The moisture sensitivity level of MEMS microphones is rated as MSL1. For PCB assembly of the MEMS microphone the widely used reflow soldering, using a forced convection oven, is recommended.

The soldering profile should be in accordance with the recommendations of the solder paste manufacturer to reach an optimal solder joint quality. The reflow profile shown in the figure below is recommended for board manufacturing with Infineon MEMS microphones.



**Figure 9 Recommended reflow profile**

**Table 9 Reflow profile limits**

Profile feature	Symbol	Pb-free assembly	Sn-Pb Eutectic assembly
Preheat temperature min.	$T_{smin}$	150°C	100°C
Preheat temperature max.	$T_{smax}$	200°C	150°C
Preheat time ( $T_{smin}$ to $T_{smax}$ )	$t_s$	60-120 seconds	60-120 seconds
Ramp-up rate ( $T_L$ to $T_p$ )	-	3°C/second max.	3°C/second max.
Liquidous temperature	$T_L$	217°C	183°C
Time maintained above $T_L$	$t_L$	60-150 seconds	60-150 seconds
Peak temperature	$T_p$	260°C +0°C/-5°C	235°C +0°C/-5°C
Time within 5°C of actual peak temperature (see note below)	$t_p$	20-40 seconds	10-30 seconds
Ramp-down rate	-	6°C/second max.	6°C/second max.
Time 25°C to peak temperature	$t$	8 minutes max.	6 minutes max.

*Note:* Tolerance for peak profile temperature ( $T_p$ ) is defined as a supplier minimum and a user maximum.



The MEMS microphones can be handled using industry standard pick and place equipment. Care should be taken to avoid damage to the microphone structure as follows:

- Do not pick the microphone with vacuum tools which make contact with the microphone acoustic port hole.
- The microphone acoustic port hole should not be exposed to vacuum. This can destroy or damage the MEMS.
- Do not blow air into the microphone acoustic port hole. If an air blow cleaning process is used, the port hole must be sealed to prevent particle contamination.
- It is recommended to perform the PCB assembly in a clean room environment in order to avoid microphone contamination.
- Air blow and ultrasonic cleaning procedures shall not be applied to MEMS Microphones. A no-clean paste is recommended for the assembly to avoid subsequent cleaning steps. The microphone MEMS can be severely damaged by cleaning substances.
- To prevent the blocking or partial blocking of the sound port during PCB assembly, it is recommended to cover the sound port with protective tape during PCB sawing or system assembly.
- Do not use excessive force to place the microphone on the PCB. The use of industry standard pick and place tools is recommended in order to limit the mechanical force exerted on the package.

*Note:* For further information please consult the "General recommendation for assembly of Infineon packages" document, which is available on the Infineon Technologies [web page](#).

## 6.4 Packing

For shipping and assembly the Infineon microphones are packed in product specific tape-and-reel carriers. A detailed drawing of the carrier can be seen in the figure below.

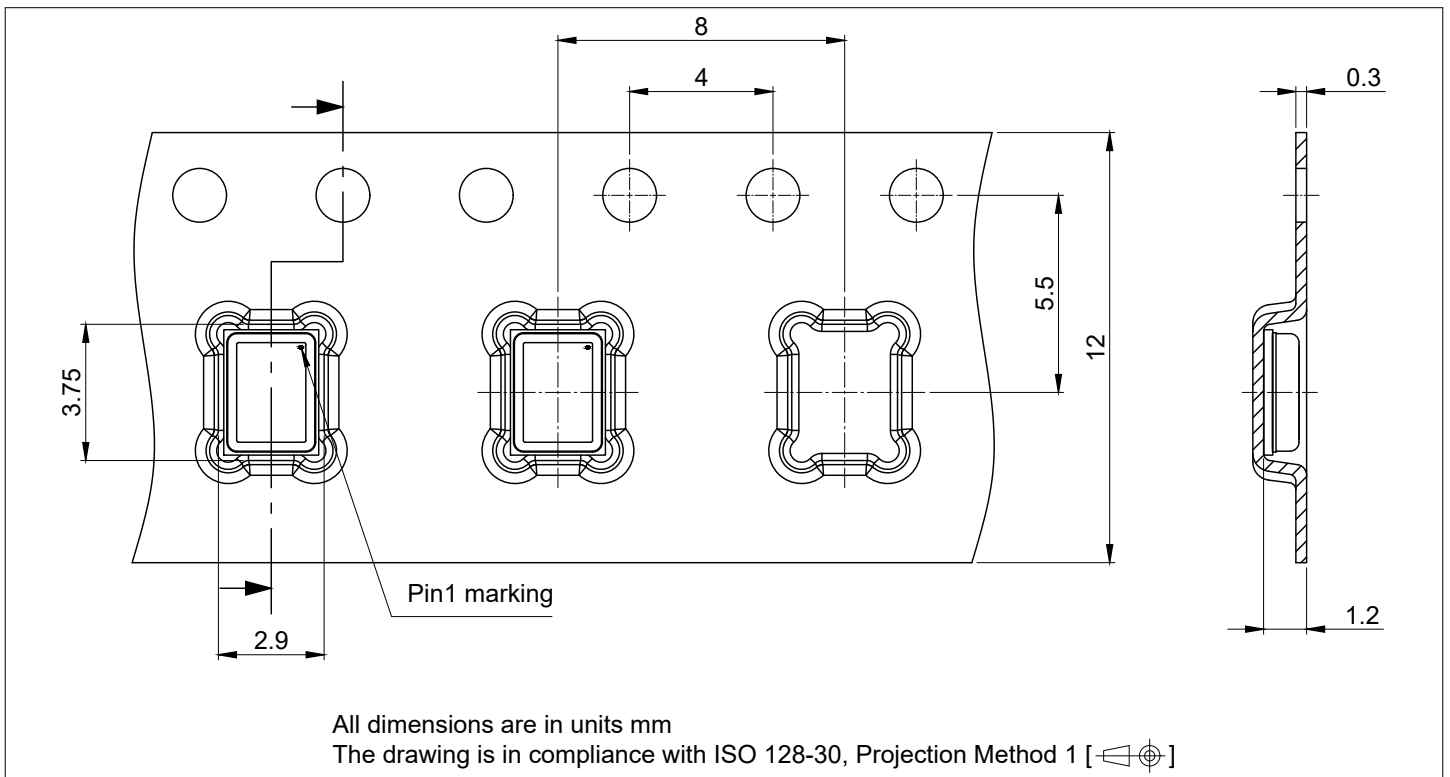

**Figure 10** Tape dimensions

More information can be found on the Infineon website:

<https://www.infineon.com/cms/en/product/packages/PG-TLGA/PG-TLGA-5-6/>

## 7 Reliability specifications

The microphone sensitivity after stress and over temperature does not deviate by more than +/- 3dB from the initial value.

**Table 10 Qualification tests according to AEC-Q103-003**

Test	Stress condition	Standard
Temperature humidity bias (THB)	$T_A = +85^\circ\text{C}$ , R.H. = 85%, $V_{DD} = 3.6\text{V}$ , cyclical bias, 1000 hours	AEC Q100 Rev.H.
Temperature humidity storage (THS)	$T_A = +85^\circ\text{C}$ , R.H. = 85%, 1000 hours	AEC Q100 Rev.H.
Temperature cycling (TC)	$T_A = -55^\circ\text{C} \dots +125^\circ\text{C}$ , 30 min cycle time, 1000cycles	AEC Q100 Rev.H.
High temperature storage life (HTSL)	$T_A = +125^\circ\text{C}$ , 1000 hours	AEC Q100 Rev.H.
High temperature operating life (HTOL)	$T_A = +125^\circ\text{C}$ , $V_{DD} = 3.6\text{V}$ , 1000 hours	AEC Q100 Rev.H.
Early life failure rate (ELFR)	$T_A = +125^\circ\text{C}$ , $V_{DD} = 3.6\text{V}$ , 48 hours	AEC Q100-008, JESD22-A108
Mechanical shock (MS)	3 pulses, 0.2msec duration, 10,000g peak acceleration in x,y and z planes	JESD22-B104
Variable frequency vibration (VfV)	20Hz to 2kHz to 20Hz (logarithmic variation) in 12 minutes, 4x in each orientation, 20g peak acceleration	JESD22-B103
Package drop (DROP)	10x on each of 6 axes (60 drops total) from a high of 1.2m onto a concrete surface	AEC Q100 Rev.H.
Humidity and temperature cycle (HTC)	5 cycles (24h/cycle)	AEC Q103-003, JESD22-A108, IEC 60068-2-2, Test-BA
Low temperature operating life (LTOL)	$T_A = -40^\circ\text{C}$ , $V_{DD} = 3.6\text{V}$ , 1000 hours	JESD22-A108, IEC 60068-2-2, Test-AA
Low temperature storage (LTS)	$T_A = -40^\circ\text{C}$ , 1000 hours	JESD22-A108, IEC 60068-2-2, Test-AA
Endurance life test (ELT)	96 hours at 130dB continuous signal	AEC Q103-003
Maximum pressure test (MPT)	160 dB SPL	AEC Q103-003
Electrostatic discharge, Human body model (HBM)	all pins, $V_{ESD} = \pm 2000\text{V}$	AEC Q100-002
Electrostatic discharge, Charged device model (CDM)	all pins, $V_{ESD} = \pm 500\text{V}$	AEC Q100-011
Latch-up	$T_A = 105^\circ\text{C}$ , $I = \pm 100\text{mA}$	AEC Q100 Rev.H.
Electromagnetic compatibility (EMC)	IC strip line radiated emissions	SAE J1752/3 – Radiated Emissions

**(table continues...)**

**Table 10** (continued) Qualification tests according to AEC-Q103-003

Test	Stress condition	Standard
Wire bond shear	–	AEC Q100-001, AEC Q003
Wire bond pull	–	MIL-STD883 Method 2011, AEC Q003
Die shear	–	MIL-STD-883 Method 2019
Solderability	–	JESD22-B102
Physical dimensions	–	JESD22-B100 and B108, AEC Q003
Acoustic characterization	Measurement of acoustic parameters over full voltage and temperature range $T_A = -40^{\circ}\text{C} \dots +105^{\circ}\text{C}$ $V_{DD} = 1.6 \text{ V} \dots 3.6 \text{ V}$	–

**Table 11** Additional tests for use in automotive applications

Test	Stress condition	Standard
Electrostatic discharge, SLT - Contact discharge	3 contact discharges of $\pm 6\text{kV}$ to lid while $V_{DD}$ is supplied according to the operational modes; $V_{DD}$ ground is separated from earth ground	IEC-61000-4-2
Electrostatic discharge, SLT - Air discharge	3 air discharges of $\pm 8\text{kV}$ to lid while $V_{DD}$ is supplied according to the operational modes; $V_{DD}$ ground is separated from earth ground	IEC-61000-4-2

## 8 Revision history

**Table 12**            **Revision history**

<b>Document revision</b>	<b>Date of release</b>	<b>Description of changes</b>
1.00	2023-11-17	<ul style="list-style-type: none"><li>• Initial release</li></ul>

## Trademarks

All referenced product or service names and trademarks are the property of their respective owners.

**Edition 2023-11-17**

**Published by**

**Infineon Technologies AG**

**81726 Munich, Germany**

**© 2023 Infineon Technologies AG**

**All Rights Reserved.**

**Do you have a question about any aspect of this document?**

**Email: [erratum@infineon.com](mailto:erratum@infineon.com)**

**Document reference**

**IFX-arc1697519482552**

## Important notice

The information given in this document shall in no event be regarded as a guarantee of conditions or characteristics ("Beschaffheitsgarantie").

With respect to any examples, hints or any typical values stated herein and/or any information regarding the application of the product, Infineon Technologies hereby disclaims any and all warranties and liabilities of any kind, including without limitation warranties of non-infringement of intellectual property rights of any third party.

In addition, any information given in this document is subject to customer's compliance with its obligations stated in this document and any applicable legal requirements, norms and standards concerning customer's products and any use of the product of Infineon Technologies in customer's applications.

The data contained in this document is exclusively intended for technically trained staff. It is the responsibility of customer's technical departments to evaluate the suitability of the product for the intended application and the completeness of the product information given in this document with respect to such application.

## Warnings

Due to technical requirements products may contain dangerous substances. For information on the types in question please contact your nearest Infineon Technologies office.

Except as otherwise explicitly approved by Infineon Technologies in a written document signed by authorized representatives of Infineon Technologies, Infineon Technologies' products may not be used in any applications where a failure of the product or any consequences of the use thereof can reasonably be expected to result in personal injury.