



Product Brief

HybridPACK™ DSC (Double Sided Cooling)

FF400R07A01E3_S6

The FF400R07A01E3_S6 is a very compact half-bridge module ($V_{CES} = 700\text{ V}$, $I_{Cnom} = 400\text{ A}$) targeting hybrid and electric vehicles. The dual in-line package is designed for double sided cooling enabling high power density inverters. The low stray inductance and increased blocking voltage supports the design of systems with a very high efficiency. Thanks to the integrated isolation the modules can be directly attached to a cooler without external isolation. The module has an on die integrated current sense (IGBT mirror) and temperature (diode) sense. These features can be used to continuously monitor the IGBT state as input for decisions and settings of system parameters during operation.

The module is based on Infineon's long-term experience developing IGBT power modules and trench-field-stop IGBTs including matching diodes with enhanced softness. Intense research efforts of new material combinations and assembly technologies enable leading thermal and electrical performance at highest reliability and mechanical robustness.

Applications

- > Main inverter and generator for hybrid and electric vehicles
- > Generator inverter for range extenders

Circuit diagram

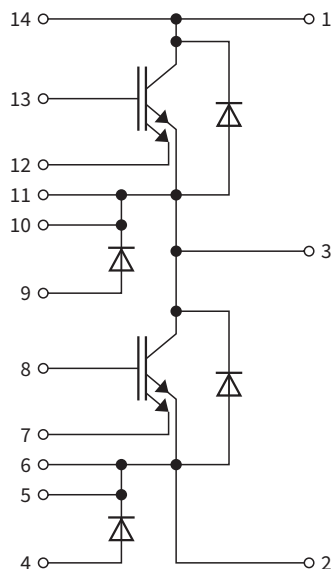

Key features

- > Superior thermal performance due to double sided cooling
- > Low inductance design with module cooling surfaces electrically isolated
- > Integrated temperature and current sense

Key benefits

- > Enables inverter designs with very high power density
- > Reduces system losses, improved efficiency and facilitates inverter design
- > Improved system monitor capabilities

HybridPACK™ DSC (Double Sided Cooling)

FF400R07A01E3_S6

Application block diagram

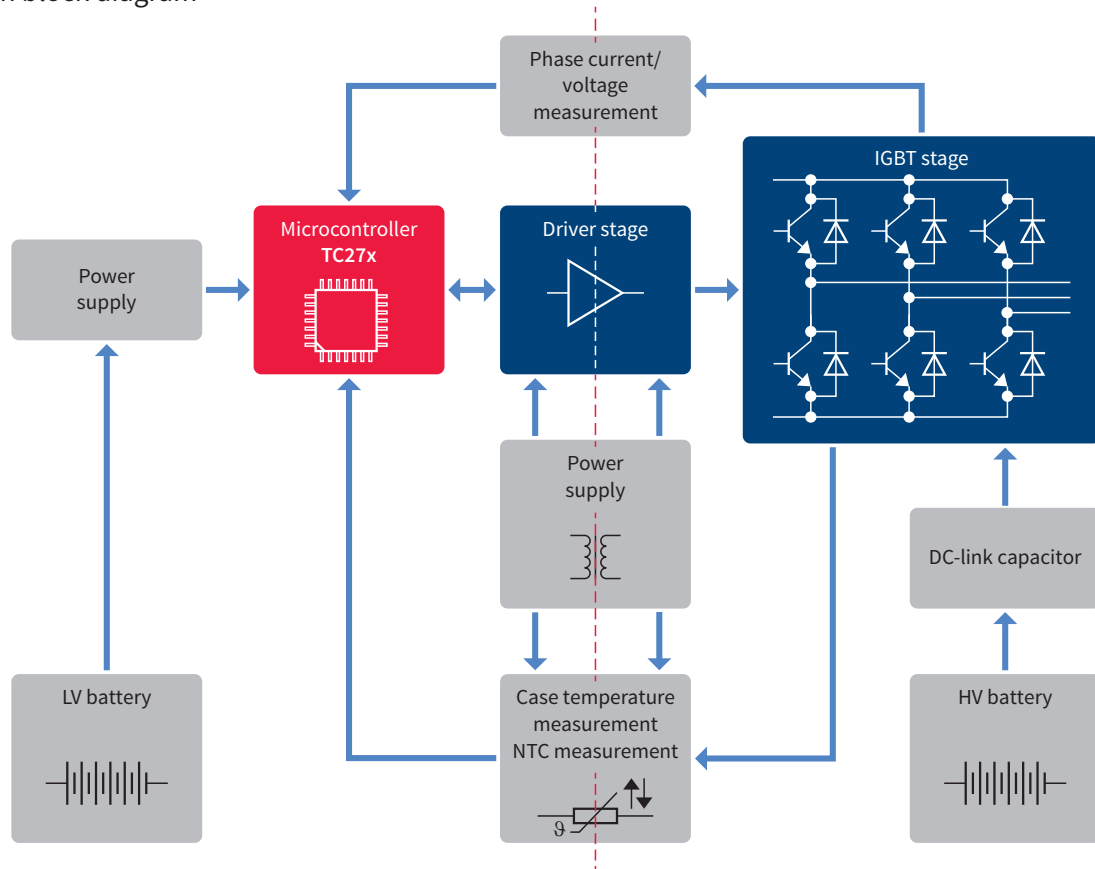

Application example for a main inverter application

Product summary

Type	Description	Ordering code
FF400R07A01E3_S6	IGBT module with double sided cooling	In development

Published by
Infineon Technologies AG
85579 Neubiberg, Germany

© 2016 Infineon Technologies AG.
All Rights Reserved.

Please note!

THIS DOCUMENT IS FOR INFORMATION PURPOSES ONLY AND ANY INFORMATION GIVEN HEREIN SHALL IN NO EVENT BE REGARDED AS A WARRANTY, GUARANTEE OR DESCRIPTION OF ANY FUNCTIONALITY, CONDITIONS AND/OR QUALITY OF OUR PRODUCTS OR ANY SUITABILITY FOR A PARTICULAR PURPOSE. WITH REGARD TO THE TECHNICAL SPECIFICATIONS OF OUR PRODUCTS, WE KINDLY ASK YOU TO REFER TO THE RELEVANT PRODUCT DATA SHEETS PROVIDED BY US. OUR CUSTOMERS AND THEIR TECHNICAL DEPARTMENTS ARE REQUIRED TO EVALUATE THE SUITABILITY OF OUR PRODUCTS FOR THE INTENDED APPLICATION.

WE RESERVE THE RIGHT TO CHANGE THIS DOCUMENT AND/OR THE INFORMATION GIVEN HEREIN AT ANY TIME.

Additional information

For further information on technologies, our products, the application of our products, delivery terms and conditions and/or prices, please contact your nearest Infineon Technologies office (www.infineon.com).

Warnings

Due to technical requirements, our products may contain dangerous substances. For information on the types in question, please contact your nearest Infineon Technologies office.

Except as otherwise explicitly approved by us in a written document signed by authorized representatives of Infineon Technologies, our products may not be used in any life-endangering applications, including but not limited to medical, nuclear, military, life-critical or any other applications where a failure of the product or any consequences of the use thereof can result in personal injury.