



Product brief

WCDSC006 - EiceDRIVER™

Ensuring robust and efficient wireless charging operation

Infineon's new WCDSC006 EiceDRIVER™ is suitable to drive both high-side and low-side MOSFETs in a half-bridge inverter configuration, especially for inductive wireless power. The inputs of the driver are TTL logic compatible and can withstand input voltages up to 7 V regardless of the VDD voltage. Although the high-side and the low-side power devices are driven independently, the driver enforces a 5 ns (typ) dead time to prevent shoot through.

The driver can be used with a wide range of power MOSFETs such as Infineon's OptiMOS™ 5. The WCDSC006 has a current capability of 4 A sink and 2 A source, in addition it offers a maximum bootstrap voltage of 60 V for high input voltage operation. It is available in a PG-WSON-10 package with exposed pad, connected to ground, to aid power dissipation.

Infineon's half-bridge drive is a perfect fit to ensure a safe wireless power transfer by achieving high robustness and efficiency.

Key features

- > -0.3 to 7 V input bin capability for increased robustness
- > Independent high-side / low-side TTL logic inputs
- > Integrated bootstrap diode
- > Maximum bootstrap voltage of 60 V
- > 4 A sink and 2 A source current capability for high-side and low-side drivers

Key benefits

- > Increased robustness
- > Faster switching mode and higher efficiency results
- > Increase flexibility
- > No need for external components
- > Higher margin and more robust operation
- > No risk of cross conduction

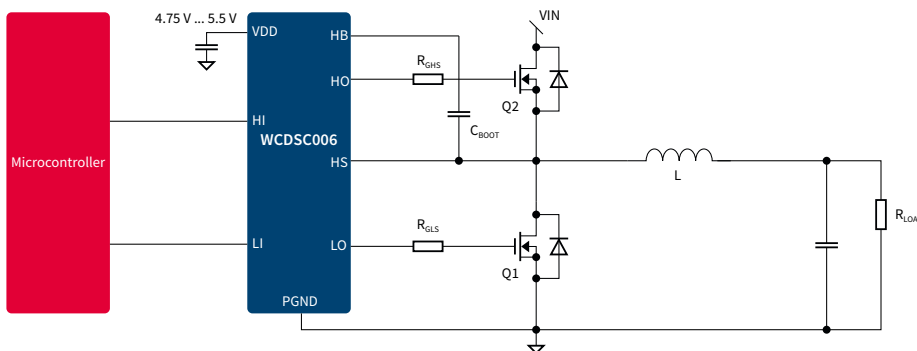

Product	Input Logic	Package Type	Voltage Class [V]	High side		Low side		UVLO max.[V]	Release status
				Peak source current [A]	Peak sink current [A]	Peak source current [A]	Peak sink current [A]		
WCDSC006	TTL	WSON-10	60	2	4	2	4	4.5	In mass production



WCDSC006 - EiceDRIVER™

Ensuring robust and efficient wireless charging operation

Block diagram – Qi solution for charging smartphones using WCDSC006

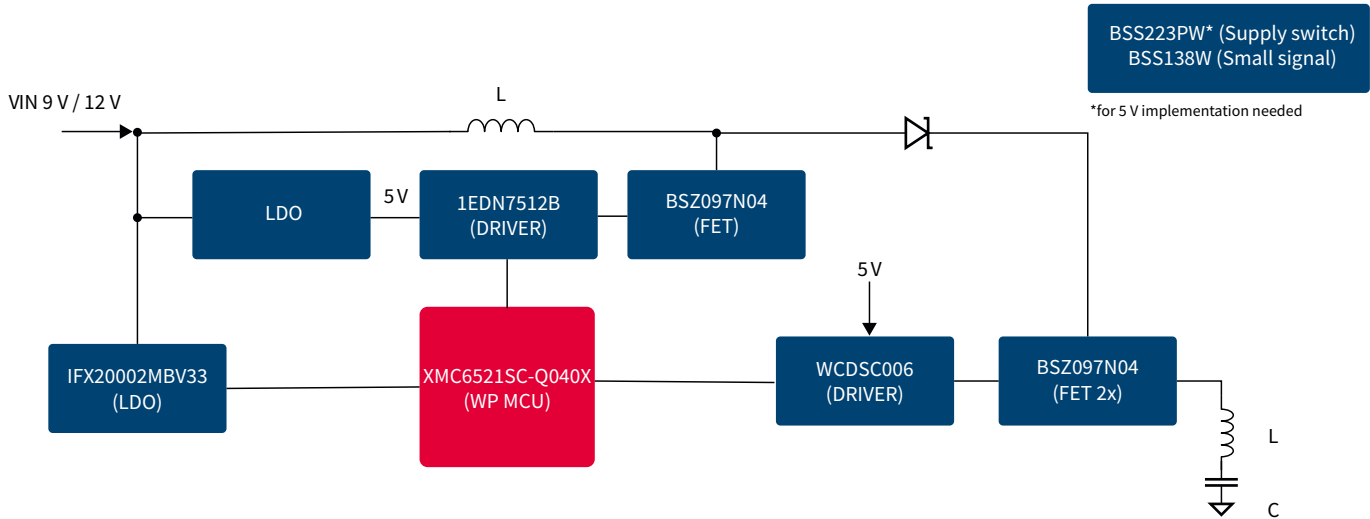

REF_10WTx_QI_4102

- > Valkyrie the 15W Qi transmitter (Tx) for charging smartphones
- > WCDSC006 as key product to ensure efficient wireless power transfer



Software IP and system solution developed by our partner.

Published by
Infineon Technologies Austria AG
9500 Villach, Austria

© 2019 Infineon Technologies AG.
All Rights Reserved.

Please note!

THIS DOCUMENT IS FOR INFORMATION PURPOSES ONLY AND ANY INFORMATION GIVEN HEREIN SHALL IN NO EVENT BE REGARDED AS A WARRANTY, GUARANTEE OR DESCRIPTION OF ANY FUNCTIONALITY, CONDITIONS AND/OR QUALITY OF OUR PRODUCTS OR ANY SUITABILITY FOR A PARTICULAR PURPOSE. WITH REGARD TO THE TECHNICAL SPECIFICATIONS OF OUR PRODUCTS, WE KINDLY ASK YOU TO REFER TO THE RELEVANT PRODUCT DATA SHEETS PROVIDED BY US. OUR CUSTOMERS AND THEIR TECHNICAL DEPARTMENTS ARE REQUIRED TO EVALUATE THE SUITABILITY OF OUR PRODUCTS FOR THE INTENDED APPLICATION.

WE RESERVE THE RIGHT TO CHANGE THIS DOCUMENT AND/OR THE INFORMATION GIVEN HEREIN AT ANY TIME.

Additional information

For further information on technologies, our products, the application of our products, delivery terms and conditions and/or prices, please contact your nearest Infineon Technologies office (www.infineon.com).

Warnings

Due to technical requirements, our products may contain dangerous substances. For information on the types in question, please contact your nearest Infineon Technologies office.

Except as otherwise explicitly approved by us in a written document signed by authorized representatives of Infineon Technologies, our products may not be used in any life-endangering applications, including but not limited to medical, nuclear, military, life-critical or any other applications where a failure of the product or any consequences of the use thereof can result in personal injury.