

TITLE: EVAL_24V_250W - New

Document Number:

REV:

Date: 15/10/2015 16:51:46

Sheet: 1/3

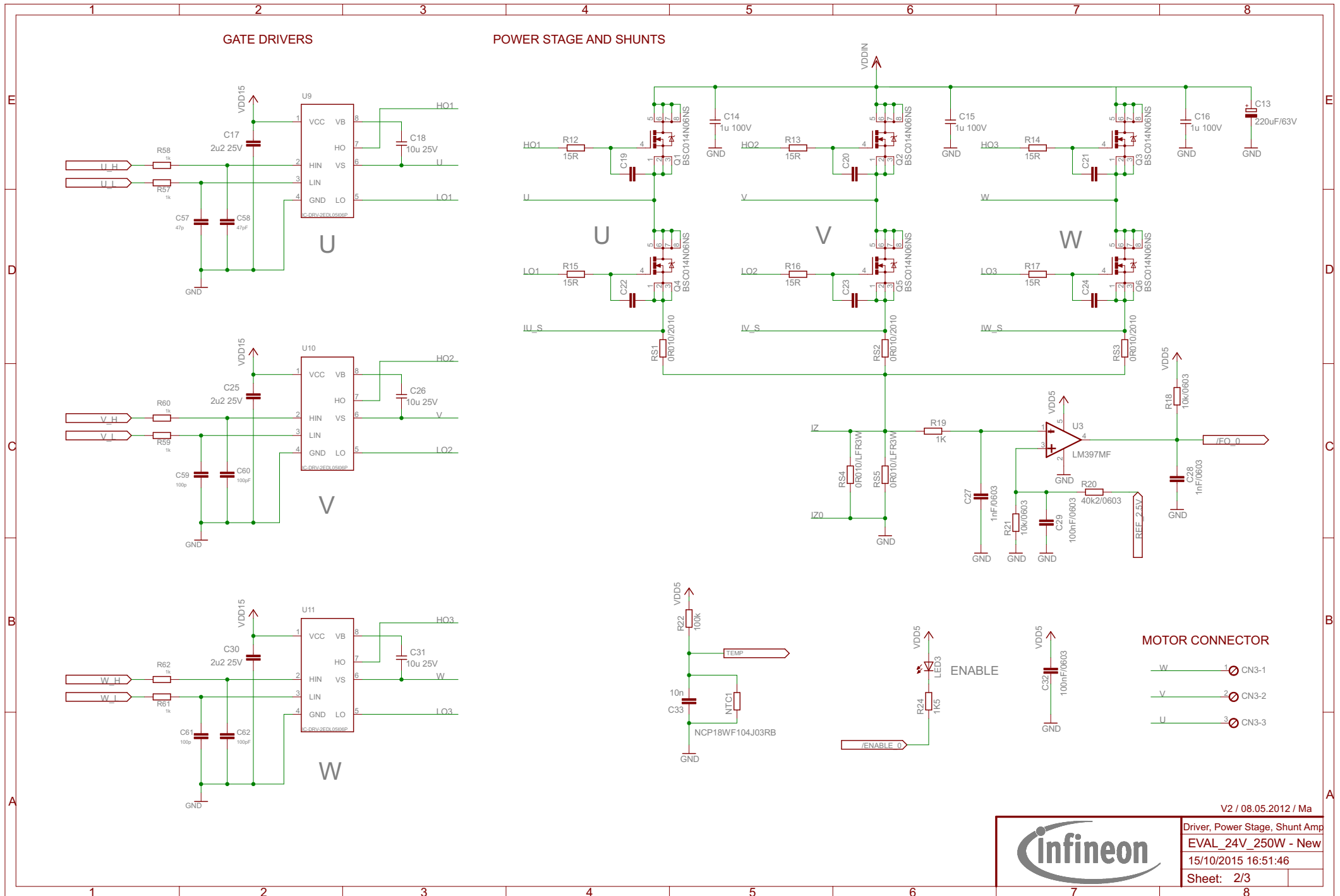

V2 / 08.05.2012 / Ma



Driver, Power Stage, Shunt Amp
 EVAL_24V_250W - New
 15/10/2015 16:51:46
 Sheet: 2/3

3 phase shunt current detection
 Offset: 2.5V
 Gain: 12

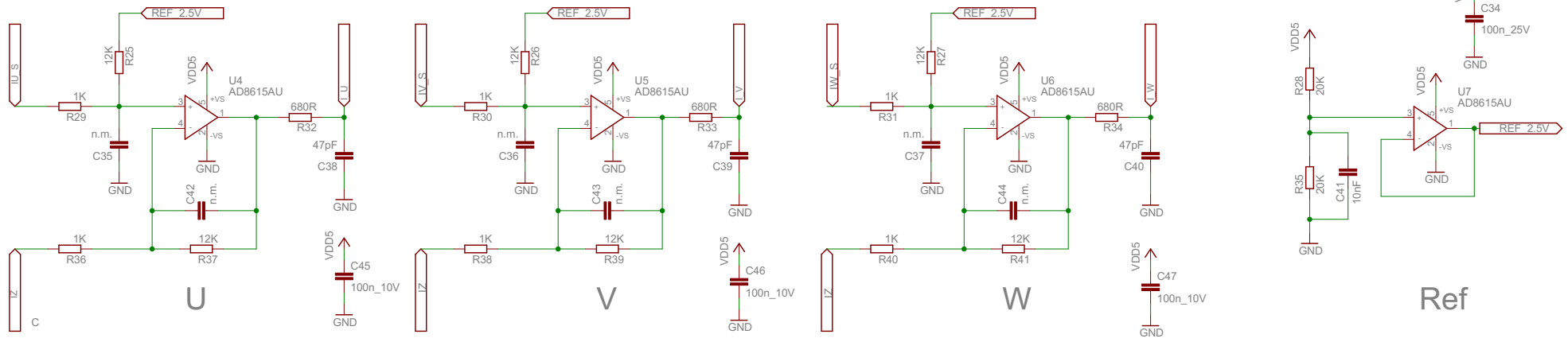

Single Shunt Current Sensing
 Offset: 2.5V
 Gain: 12

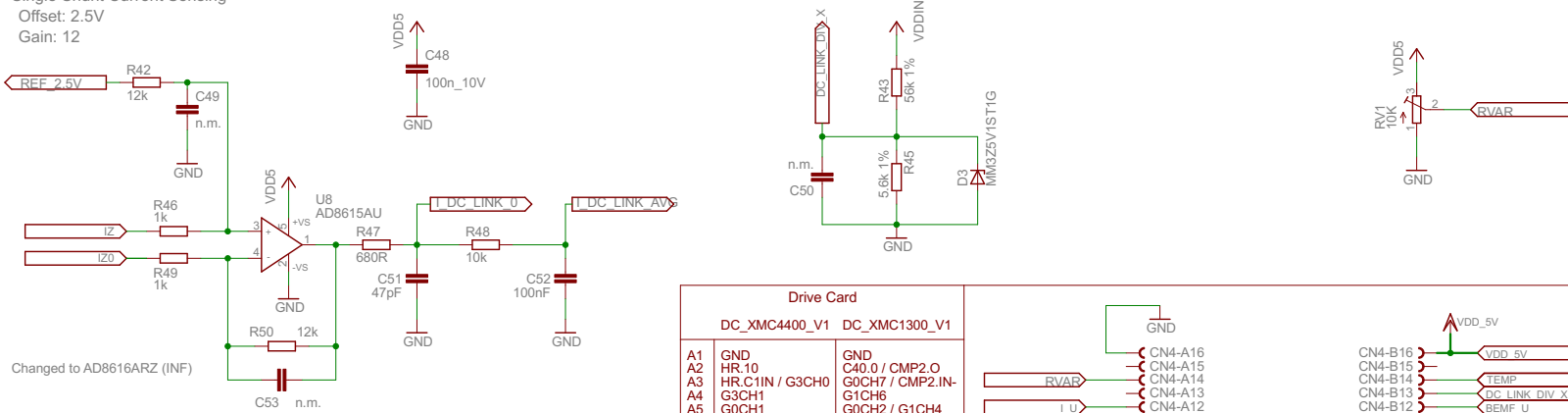

Changed to AD8616ARZ (INF)

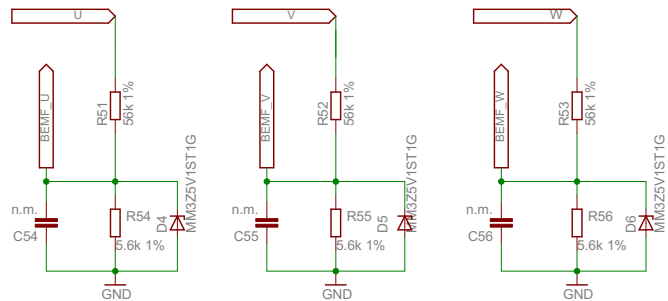

Drive Card	
DC_XMC4400_V1	DC_XMC1300_V1
A1	GND
A2	HR_10
A3	HR_C1IN / G3CH0
A4	G3CH1
A5	G0CH1
A6	G0CH3 / G1CH3
A7	G0CH5 / G2CH1
A8	G1CH0 / G3CH2
A9	C81.01 / C80.02
A10	C81.00 / C80.03
A11	C81.11 / C80.22
A12	C81.10 / C80.23
A13	C81.21 / C80.32
A14	C81.20 / C80.33
A15	ERU1.2B0 (PD1)
A16	P4.1
	C40.0 / CMP2.O
	G0CH7 / CMP2.IN-
	G1CH6
	G0CH2 / G1CH4
	G0CH3 / G1CH2
	G0CH4 / G1CH3
	G0CH6

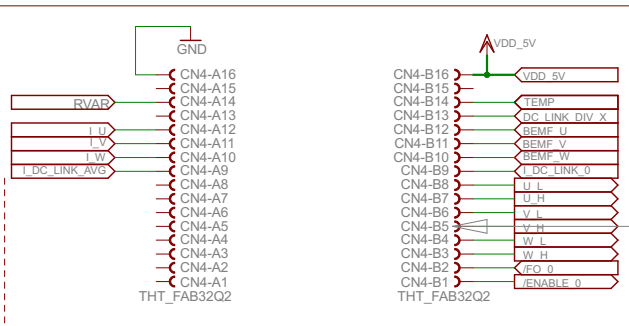

Drive Card	
DC_XMC1300_V1	DC_XMC4400_V1
VDD	VDD
-	C42.0
-	G2CH3
G1CH5	G1CH1 / G3CH3
G0CH0	G0CH0
G0CH1	G0CH0
G0CH3	G0CH2 / G1CH2
G1CH1	G0CH4 / G2CH0
C80.01	G1CH6 / G1.0RC6
C80.00	C80.01 / HR.01
C80.11	C80.00 / HR.00
C80.10	C80.20 / C80.11 / HR.20
C80.10	C80.21 / C80.10 / HR.21
C80.21 / C80.03	C80.12 / C80.21 / HR.31
C80.20 / C80.02	C80.13 / C80.20 / HR.30
C80.IN0_1,2,3	C80.IN0_1,2,3
P0.11	P0.12
	B1
	B2
	B3
	B4
	B5
	B6
	B7
	B8
	B9
	B10
	B11
	B12
	B13
	B14
	B15
	B16

Legal Disclaimer

The information given in this document shall in no event be regarded as a guarantee of conditions or characteristics. With respect to any examples or hints given herein, any typical values stated herein and/or any information regarding the application of the device, Infineon Technologies hereby disclaims any and all warranties and liabilities of any kind, including without limitation, warranties of non-infringement of intellectual property rights of any third party.



EVAL_24V_250W - New
 15/10/2015 16:51:46
 Sheet: 3/3