

24 W 12 V 5 V SMPS demo board with ICE5QR2280BG

DEMO_5QR2280BG_24W1

About this document

Scope and purpose

This document is an engineering report that describes a universal-input 24 W 12 V 5 V off-line Flyback converter using the newest fifth-generation Infineon Quasi-Resonant (QR) CoolSET™ ICE5QR2280BG. It offers high-efficiency, low-standby power with selectable entry and exit standby power options, a wide V_{CC} operating range with fast start-up, robust line protection with input Over-Voltage Protection (OVP), and brown-out and various modes of protection for a highly reliable system. This demo board is designed for users who wish to evaluate the performance of [ICE5QR2280BG](#) and its ease-of-use.

Intended audience

This document is intended for power-supply design/application engineers, students, etc., who wish to design low-cost and highly reliable systems of off-line SMPS, such as auxiliary power supplies for white goods, PCs, servers and TVs, or enclosed adapters for Blu-ray players, set-top boxes, games consoles, etc.

Table of contents

About this document	1
Table of contents	1
1 Abstract	3
2 Demo board	4
3 Specifications of the demo board	5
4 Circuit description	6
4.1 Line input.....	6
4.2 Start-up.....	6
4.3 Integrated MOSFET and PWM control	6
4.4 RCD clamper circuit.....	6
4.5 Output stage.....	6
4.6 Feedback loop	6
4.7 Primary-side peak-current control	6
4.8 Digital frequency reduction	7
4.9 Active Burst Mode (ABM)	7
5 Protection features	8
6 Circuit diagram	9
7 PCB layout	10
7.1 Top side	10
7.2 Bottom side	10
8 Bill of Materials (BOM)	11
9 Transformer construction	13
10 Test results	14

Abstract

10.1	Efficiency, regulation and output ripple.....	14
10.2	Standby power	15
10.3	Line regulation	16
10.4	Load regulation	17
10.5	Maximum input power	18
10.6	ESD immunity (EN 61000-4-2)	18
10.7	Surge immunity (EN 61000-4-5)	18
10.8	Conducted emissions (EN 55022 class B)	18
10.9	Thermal measurement	21
11	Waveforms and scope plots.....	22
11.1	Start-up at low/high AC-line input voltage with maximum load.....	22
11.2	Soft-start.....	22
11.3	Drain and CS voltage at maximum load	23
11.4	Zero crossing point during normal operation.....	23
11.5	Load-transient response (dynamic load from 10 percent to 100 percent)	24
11.6	Output ripple voltage at maximum load	24
11.7	Output ripple voltage at ABM 1 W load.....	25
11.8	Entering ABM	25
11.9	During ABM	26
11.10	Leaving ABM	26
11.11	Line OVP (non-switch auto-restart)	27
11.12	Brown-out protection (non-switch auto-restart).....	27
11.13	V _{CC} OVP (odd-skip auto restart).....	28
11.14	V _{CC} Under-Voltage Protection (UVP) (auto-restart)	28
11.15	Over-load protection (odd-skip auto-restart)	29
11.16	Output OVP (odd-skip auto-restart)	29
11.17	V _{CC} short-to-GND protection	30
12	References	31
	Revision history.....	32

Abstract

1 Abstract

This is an engineering report for a 24 W 12 V 5 V demo board designed in a QR Flyback converter topology using the fifth-generation QR CoolSET™ ICE5QR2280BG. The target applications of [ICE5QR2280BG](#) are set-top boxes, portable games controllers and Blu-ray/DVD players, as well as auxiliary power supplies for home appliances/white goods, PCs, printers, TVs, home theater/audio systems, etc. With the CoolMOS™ integrated into this IC, it greatly simplifies the design and layout of the PCB. The improved digital frequency reduction with proprietary QR operation offers lower EMI and higher efficiency for a wide AC range by reducing the switching frequency difference between low- and high-line. The enhanced Active Burst Mode (ABM) power enables flexibility in standby power operation range selection, and QR operation during ABM. As a result, the system efficiency over the entire load range is significantly improved compared to a conventional free-running QR converter implemented with only maximum switching frequency limitation at light loads. In addition, numerous adjustable protection functions have been implemented in ICE5QR2280BG to protect the system and customize the IC for the chosen application. In case of failure modes such as brown-out or line over-voltage, V_{CC} over-/under-voltage, open control-loop or over-load, output over-voltage, over-temperature, and V_{CC} short-to-ground, the device enters protection mode. By means of the cycle-by-cycle Peak Current Limitation (PCL), the dimensions of the transformer and the current rating of the secondary diode can both be optimized. Thus, a cost-effective solution can easily be achieved.

2 Demo board

This document contains the list of features, the power supply specifications, schematics, Bill of Materials (BOM) and the transformer construction documentation. Typical operating characteristics such as performance curve and scope waveforms are shown at the end of the report.



Figure 1 DEMO_5QR2280BG_24W1

Specifications of the demo board

3 Specifications of the demo board

Table 1 Specifications of DEMO_5QR2280BG_24W1

Input voltage and frequency	85 V AC (60 Hz) ~ 300 V AC (50 Hz)
Output voltage, current and power	(12 V x 1.92 A) + (5 V x 0.2 A) = 24 W
Regulation	+5 V: less than ±5 percent +12 V: less than ±10 percent
Output ripple voltage (full load, 85 V AC ~ 300 V AC)	5 V _{ripple_p_p} less than 100 mV 12 V _{ripple_p_p} less than 200 mV
Active-mode four-point average efficiency (25 percent, 50 percent, 75 percent, 100 percent load)	More than 83 percent at 115 V AC and 230 V AC
No-load power consumption	Less than 100 mW at 230 V AC
Conducted emissions (EN 55022 class B)	Pass with 6 dB margin for 115 V AC and 6 dB margin for 230 V AC
ESD immunity (EN 61000-4-2)	Special level (±14 kV for contact and 6±14 kV air discharge)
Surge immunity (EN 61000-4-5)	Installation class 4 (±2 kV for line-to-line and ±4 kV for line-to-earth)
Form factor case size (L x W x H)	(110 x 66 x 27) mm ³

Note: The demo board is designed for dual-output with cross-regulated loop feedback (FB). It may not regulate properly if loading is applied only to single-output. If the user wants to evaluate for single-output (12 V only) conditions, the following changes are necessary on the board.

1. Remove D6, L3, C10A, C10B, R16 (to disable 5 V output).
2. Change R21A to 10 kΩ and R16 to 38 kΩ (to disable 5 V FB and enable 100 percent weighted factor on 12 V output).

Since the board (especially the transformer) is designed for dual-output with optimized cross-regulation, single-output efficiency might not be optimized. It is only for IC functional evaluation under single-output conditions.

Circuit description

4 Circuit description

4.1 Line input

The AC-line input side comprises the input fuse F1 as over-current protection. The choke L1, X-capacitors CX1 and CX2 and Y-capacitor CY1 act as EMI suppressors. The spark-gap and varistor Z1 can absorb HV stress during a lightning surge test. A rectified DC voltage (120 ~ 424 V DC) is obtained through the bridge rectifier BR1 together with the bulk capacitor C1.

4.2 Start-up

To achieve fast and safe start-up, ICE5QR2280BG is implemented with a start-up resistor and V_{CC} short-to-GND protection. When V_{VCC} reaches the turn-on voltage threshold 16 V, the IC begins with a soft-start. The soft-start implemented in ICE5QR2280BG is a digital time-based function. The preset soft-start time is 12 ms with four steps. If not limited by other functions, the peak voltage on the CS pin will increase in increments from 0.3 V to 1 V. After IC turn-on, the V_{CC} voltage is supplied by auxiliary windings of the transformer. V_{CC} short-to-GND protection is implemented during the start-up time.

4.3 Integrated MOSFET and PWM control

ICE5QR2280BG is comprised of a power MOSFET and the new proprietary QR controller, which enables higher average efficiency and low EMI. This integrated solution greatly simplifies the circuit layout and reduces the cost of PCB manufacture. The PWM switch-on is determined by the Zero Crossing Detection (ZCD) input signal and the value of the up/down counter. The PWM switch-off is determined by the FB signal V_{FB} and the CS signal V_{CS} . ICE5QR2280BG also performs all necessary protection functions in Flyback converters. Details about the information mentioned above are illustrated in the product datasheet.

4.4 RCD clamper circuit

A clamper network (R4, C2 and D1) dissipates the energy of the leakage inductance and suppresses ringing on the SMPS transformer.

4.5 Output stage

There are two outputs on the secondary side, 12 V and 5 V. The power is coupled out via Schottky diodes D5 and D6. The capacitors C9A and C10A provide energy buffering, followed by the L-C filters L2-C9B and L3-C10B to reduce the output ripple and prevent interference between SMPS switching frequency and line frequency. Storage capacitors C9A and C10A are designed to have as small an internal resistance (ESR) as possible to minimize the output voltage ripple caused by the triangular current.

4.6 Feedback loop

For FB, the output is sensed by the voltage divider of R16, R17, R21A and R21B and compared to the IC3 (TL431) internal reference voltage. C11, C14 and R18 comprise the compensation network. The output voltage of IC3 (TL431) is converted to the current signal via optocoupler IC2 and two resistors, R19 and R20, for regulation control.

4.7 Primary-side peak-current control

The MOSFET drain-source current is sensed via external resistors R8A and R8B. Since ICE5QR2280BG is a current mode controller, it would have a cycle-by-cycle primary current and FB voltage control, which ensures the converter's maximum power is controlled in every switching cycle.

Circuit description

For a QR Flyback converter, the maximum possible output power is increased when a constant current limit value is used for the whole-line input voltage range. This is usually not desirable, as this will increase the cost of the transformer and output diode in case of output over-power conditions.

Internal current limitation with a line-dependent V_{CS} curve and the new proprietary QR switching, which reduces switching frequency difference between the minimum and maximum line, are implemented in the ICE5QR2280BG. As a result, the maximum output power can be limited against the input voltage.

4.8 Digital frequency reduction

During normal operation, the switching frequency for ICE5QR2280BG is digitally reduced with decreasing load. At light loads, the MOSFET will be turned on – not at the first minimum drain-source voltage time, but on the n^{th} . The counter is within a range of 1 to 8 for low-line and 3 to 10 for high-line, which depends on FB voltage in a time-base. The FB voltage decreases when the output power requirement decreases, and vice versa. Therefore, the counter is set by monitoring voltage V_{FB} . The counter will be increased with low V_{FB} and decreased with high V_{FB} . The thresholds are preset inside the IC.

4.9 Active Burst Mode (ABM)

ABM entry and exit power (two levels) can be selected in ICE5QR2280BG. Details are illustrated in the product datasheet. In light load conditions, the SMPS enters into ABM with QR switching. At this stage, the controller is always active but the V_{VCC} must be kept above the switch-off threshold. During ABM, the efficiency increases significantly and at the same time it supports low ripple on V_{out} and fast response on load-jump.

For determination of entering ABM operation, three conditions apply:

1. The FB voltage is lower than the threshold of V_{FBEB}
2. The up/down counter is 8 for low-line and 10 for high-line, and
3. A certain blanking time ($t_{BEB} = 20$ ms) is required

Once all of these conditions are fulfilled, the ABM flip-flop is set and the controller enters ABM operation. This multi-condition determination for entering ABM operation prevents mis-triggering of ABM, so that the controller enters ABM operation only when the output power is really low during the preset blanking time.

During ABM, the maximum CS voltage is reduced from 1 V to 0.31/0.35 V to reduce the conduction loss and the audible noise. In ABM, the FB voltage changes like a sawtooth between 2 V and 2.4 V.

The FB voltage immediately increases if there is a high load-jump. This is observed by one comparator. As the current limit is 31/35 percent during ABM a certain load is needed so that FB voltage can exceed V_{FBLB} (2.75 V). After leaving ABM, maximum current can now be provided to stabilize V_{out} . In addition, the up/down counter will be set to 1 (low-line) or 3 (high-line) immediately after leaving ABM. This is helpful to decrease the output voltage undershoot.

Protection features

5 Protection features

Protection is one of the major factors in determining whether the system is safe and robust – therefore sufficient protection is necessary. ICE5QR2280BG provides comprehensive protection to ensure the system is operating safely. This includes line over-voltage, brown-out, V_{CC} over-voltage and under-voltage, over-load, output over-voltage, over-temperature (controller junction), CS short-to-GND and V_{CC} short-to-GND. When those faults are found, the system will enter protection mode. Once the fault is removed, the system resumes normal operation. A list of protections and failure conditions are shown in the table below.

Table 2 Protection functions of ICE5QR2280BG

Protection function	Failure condition	Protection mode
Line over-voltage	V_{VIN} more than 2.9 V	Non-switch auto-restart
Brown-out	V_{VIN} less than 0.4 V	Non-switch auto-restart
V_{CC} over-voltage	V_{VCC} more than 25 V	Odd-skip auto-restart
V_{CC} under-voltage	V_{VCC} less than 10 V	Auto-restart
Over-load	V_{FB} more than 2.75 V and lasts for 30 ms	Odd-skip auto-restart
Output over-voltage	V_{ZCD} more than 2 V and lasts for 10 consecutive pulses	Odd-skip auto-restart
Over-temperature (junction temperature of controller chip only)	T_J more than 140°C	Non-switch auto-restart
V_{CC} short-to-GND ($V_{VCC} = 0$ V, $R_{StartUp} = 50$ M Ω and $V_{Drain} = 90$ V)	V_{VCC} less than 1.2 V, $I_{VCC_Charge1} \approx 0.2$ A	Cannot start up

Circuit diagram

6 Circuit diagram

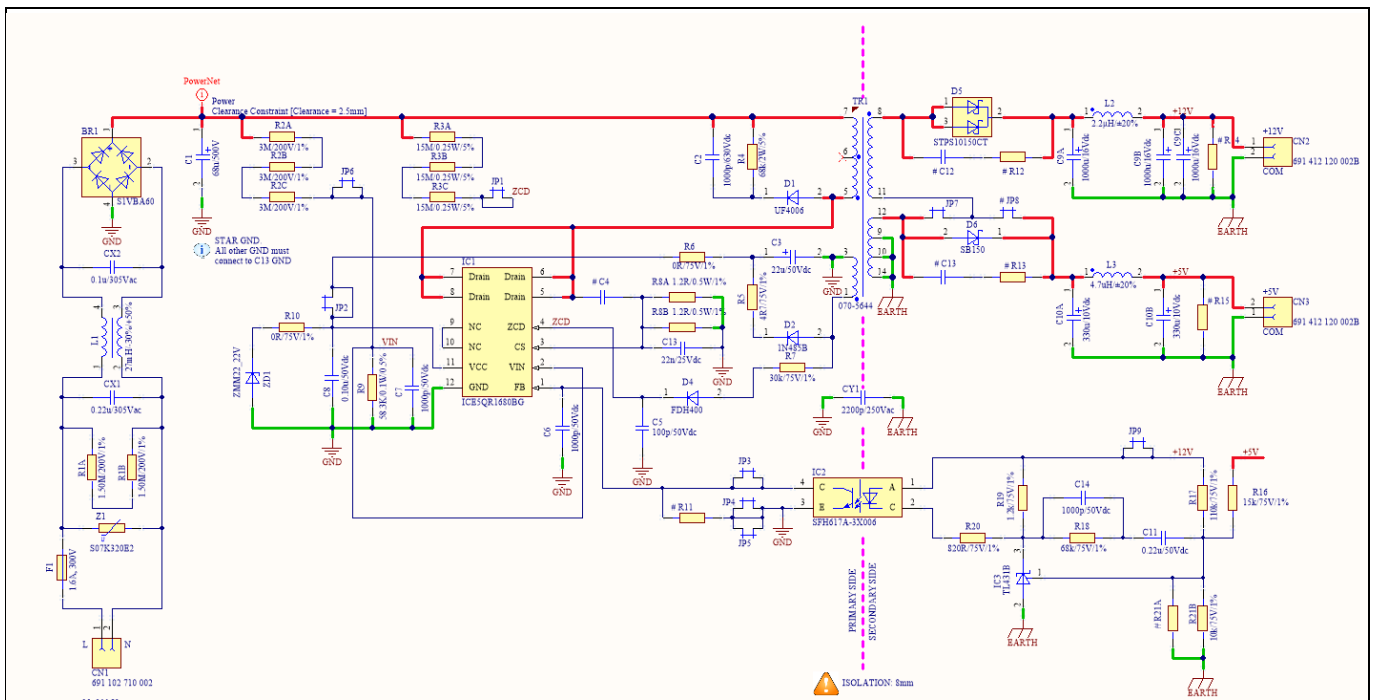

Figure 2 Schematic of DEMO_5QR2280BG_24W1

Note: General guidelines for layout design of PCB:

1. Star ground at bulk capacitor C1: all primary grounds should be connected to the ground of bulk capacitor C1 separately in one point. This effectively reduces the switching noise going into the sensitive pins of the CoolSET™ device. The primary star ground can be split into four groups, as follows:
 - i. Combine signal (all small-signal grounds connecting to the CoolSET™ GND pin, such as filter capacitor grounds C6, C7, C8 and optocoupler ground) and power grounds (CS resistors R8A and R8B)
 - ii. V_{CC} ground includes the V_{CC} capacitor ground C3 and the auxiliary winding ground, pin 3 of the power transformer
 - iii. EMI return ground includes Y capacitor CY1
 - iv. DC ground from bridge rectifier BR1
2. Filter capacitor close to the controller ground: filter capacitors C6, C7 and C8 should be placed as close to the controller ground and the controller pin as possible to reduce the switching noise coupled into the controller.
3. HV traces clearance: HV traces should retain enough spacing from the nearby traces. Otherwise, arcing could occur.
 - i. 400 V traces (positive rail of bulk capacitor C1) to nearby trace: greater than 2.0 mm
 - ii. 600 V traces (drain voltage of CoolSET™ IC1) to nearby trace: greater than 2.5 mm
4. Recommended minimum 232 mm² copper area at drain pin to add on PCB for better thermal performance.
5. Power-loop area (bulk capacitor C1, primary winding of the transformer TR1 (pins 7 and 5), IC1 drain pin, IC1 CS pin and CS resistor R8A/R8B) should be as small as possible to minimize the switching emissions.

PCB layout

7 PCB layout

7.1 Top side

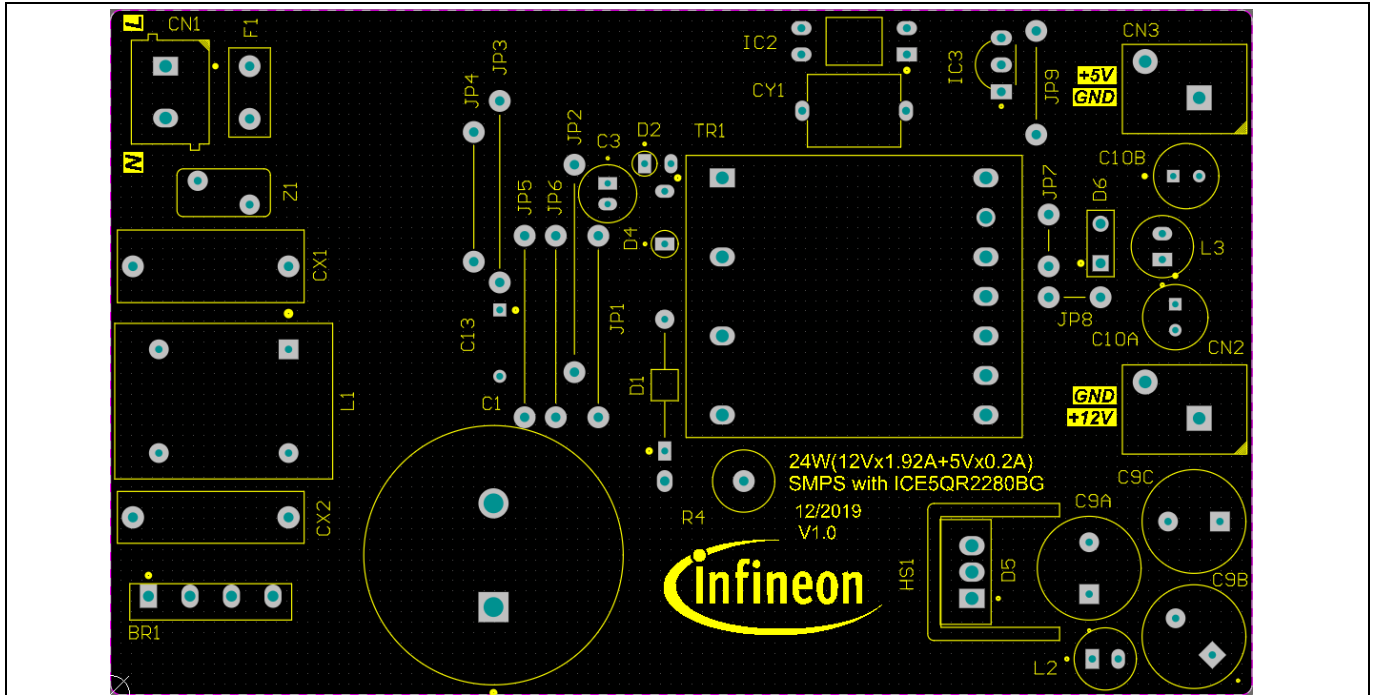

Figure 3 Top-side component legend

7.2 Bottom side

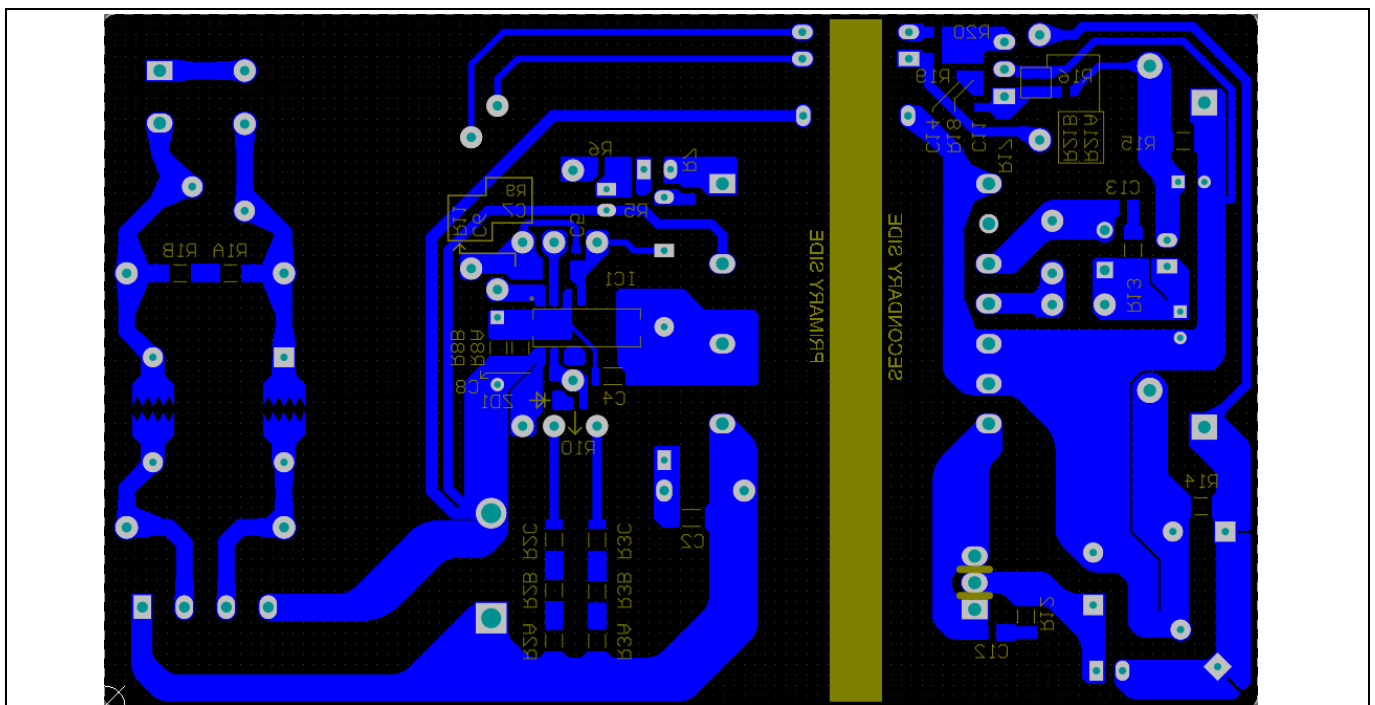

Figure 4 Bottom-side copper and component legend

Bill of Materials (BOM)

8 Bill of Materials (BOM)

Table 3 BOM (V 0.7)

No.	Designator	Description	Part number	Manufacturer	Quantity
1	BR1	600 V/1 A	S1VBA60	Shindengen	1
2	CX1	0.22 μ F/305 V	B32922C3224	Epcos	1
3	CY1	2.2 nF/500 V	DE1E3RA222MA4BQ	Murata	1
4	C1	68 μ F/500 V	LGN2H680MELA25	Nichicon	1
5	CX2	0.1 μ F/305 V	B329221C3104K	Epcos	1
6	C2	1 nF/1000 V	GRM31BR73A102KW01#	Murata	1
7	C3	22 μ F/50 V	50PX22MEFC5X11	Rubycon	1
8	C8	100 nF/50 V	GRM188R71H104KA93D	Murata	1
9	C6, C7, C14	1 nF/50 V	GRM1885C1H102GA01D	Murata	3
10	C5	100 pF/50 V	GRM1885C1H101GA01D	Murata	1
11	C9A, C9B, C9C	1000 μ F/16 V	16ZLH1000MEFC10X16	Rubycon	3
12	C11	220 nF/50 V	GRM188R71H224KAC4D	Murata	1
13	C12	100 pF/250 V	GRM21A5C2E101FW01D	Murata	1
14	C10A, C10B	330 μ F/10 V	10ZLH330MEFC6.3X11	Rubycon	2
15	C100	22 nF/25 V	GRM188B11E223KA01D	Murata	1
16	D1	1 A/800 V	UF4006		1
17	D2	0.2 A/200 V	1N485B		1
18	D4	0.2 A/150 V/50 ns	FDH400		1
19	D5	10 A/150 V	STPS10150CT	STMicroelectronics	1
20	D6	1 A/45 V	SB150	Vishay	1
21	F1	1.6 A/300 V	36911600000	Littlefuse	1
22	HS1	Heatsink	577202B00000G	AAVID	1
23	IC1	ICE5QR2280BG	ICE5QR2280BG	Infineon	1
24	IC2	Optocoupler	SFH617A-3		1
25	IC3	Shunt regulator	TL431BVLPG		1
26	L1	27 mH/0.7 A	B82731M2701A030	Epcos	1
27	L2	2.2 μ H/4.3 A	744 746 202 2	Würth Electronics	1
28	L3	4.7 μ H/4.2 A	744 746 204 7	Würth Electronics	1
29	R4	68 k Ω /2 W/500 V	MO2CT631R683J	KOA Speer	1
30	R6, R10	0 Ω (0603)			2
31	R5	4.7 Ω (0603)			1
32	R8A	1.2 R/0.25 W/ \pm 1 percent	ERJ8RQF1R2V	Panasonic	1
33	R8B	1.3 Ω /0.33 W/ \pm 1 percent	ERJ8BQF1R3V	Panasonic	1
34	R7	30 k Ω / \pm 1 percent (0603)			1
35	R3A, R3B, R3C	15 MR/0.25 W/5 percent	RC1206JR-0715ML		3
36	R2A, R2B, R2C	3 MR/0.25 W/1 percent	RC1206FR-073ML		3
37	R19	58.3 k Ω /0.1 W/0.5 percent	RT0603DRE0758K3L		1
38	R1A, R1B	1.5 M Ω /5 percent/200 V	RC1206FR-071M5L		2
39	R20	820 Ω (0603)			1
40	R19	1.2 k Ω (0603)			1

24 W 12 V 5 V SMPS demo board with ICE5QR2280BG

DEMO_5QR2280BG_24W1AN_DEMO_5QR2280BG_24W1



Bill of Materials (BOM)

41	R18	68 k Ω (0603)			1
42	R17	110 k Ω (0603)			1
43	R16	15 k Ω (0603)			1
44	R21A	10 k Ω (0603)			1
45	R12	51 Ω (1206)			
46	TR1	400 μ H	750343101	Würth Electronics	1
47	Z1	0.25 W/320 V	B72207S2321K101	Epcos	1
48	ZD1	22 V Zener			1
49	CN1 (L N)	Connector	691102710002	Würth Electronics	1
50	CN2 (+12 V com), CN3 (+5 V com)	Connector	691 412 120 002B	Würth Electronics	2
51	C13	22 nF/25 V	K223K15X7RF5UL2	Vishay	1

Transformer construction

9 Transformer construction

Core and materials: EE25/13/7(EF25), TP4A (TDG)

Bobbin: 070-5644 (14-pin, THT, horizontal version)

Primary inductance: $L_p = 400 \mu\text{H}$ (± 10 percent), measured between pin 5 and pin 7

Manufacturer and part number: Würth Electronics Midcom (750343101)

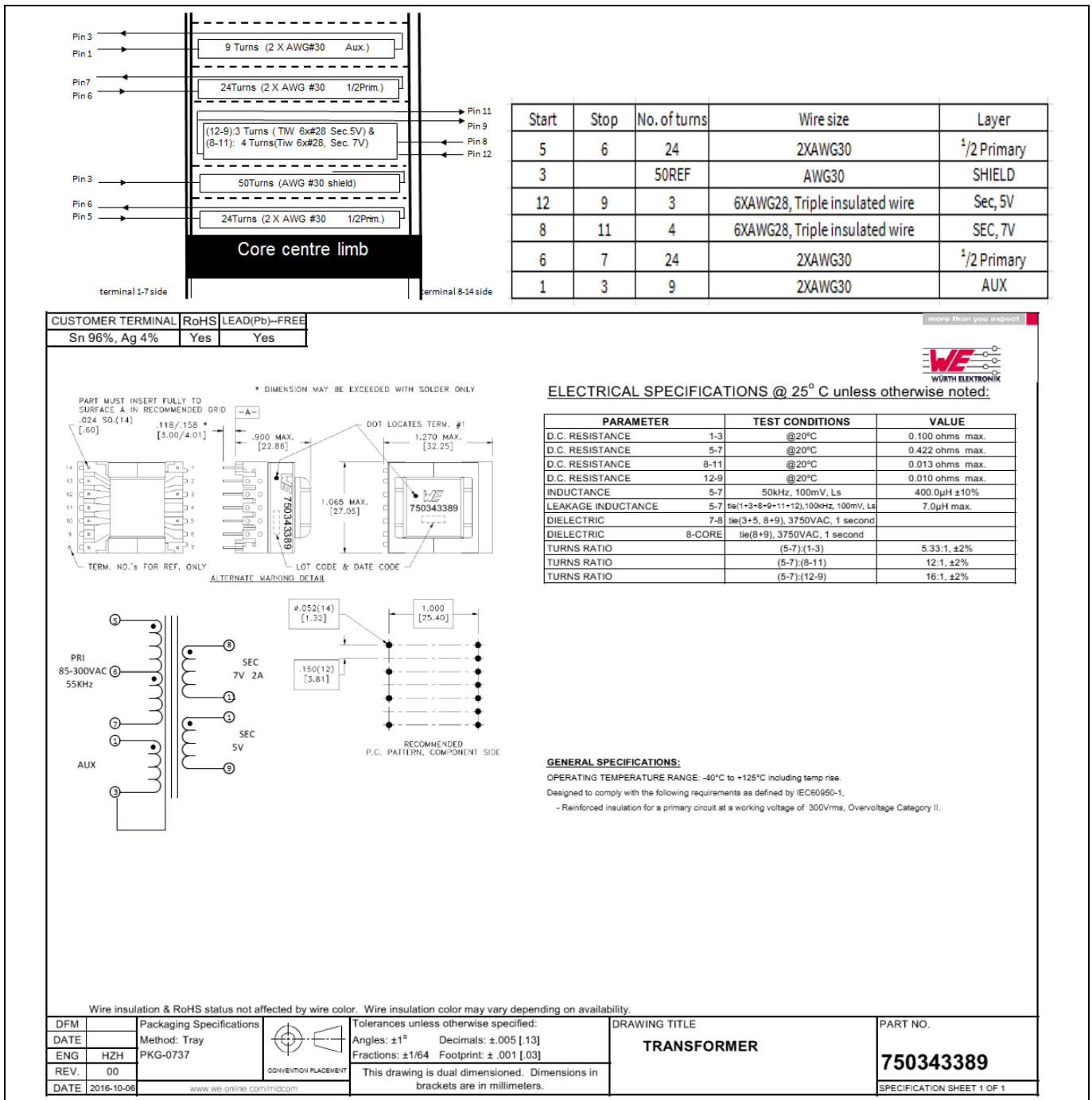

Figure 5 Transformer structure

Test results

10 Test results

10.1 Efficiency, regulation and output ripple

Table 4 Efficiency, regulation and output ripple

Input (V AC/Hz)	P _{in} (W)	V _{out1} (V DC)	I _{out1} (A)	V _{outRPP1} (mV)	V _{out2} (V DC)	I _{out2} (A)	V _{outRPP2} (mV)	P _{out} (W)	Efficiency η (%)	Average η (%)	OLP P _{in} (W)	OLP I _{out12V} (fixed 5 V at 0.2 A) (A)
85 V AC/ 60 Hz	0.033	11.83	0.000	48.0	4.96	0.000	10.9				38.40	2.61
	0.08	12.85	0.000	23.7	4.82	0.006	45.4	0.03				
	14.591	11.75	1.000	35.8	4.97	0.060	9.0	12.05	82.57			
	7.372	11.82	0.500	29.4	4.96	0.050	8.3	6.16	83.53	83.06		
	14.76	11.83	1.000	34.6	4.96	0.100	9.0	12.33	83.51			
	22.2	11.83	1.500	35.8	4.96	0.150	9.6	18.49	83.28			
28.99	11.85	1.920	47.4	4.96	0.200	12.2	23.74	81.90				
115 V AC/ 60 Hz	0.039	11.83	0.000	48.0	4.96	0.000	11.5				43.52	3.01
	0.085	12.85	0.000	23.7	4.83	0.006	47.4	0.03				
	14.282	11.73	1.000	36.5	4.97	0.060	9.6	12.03	84.22			
	7.364	11.81	0.500	28.8	4.96	0.050	9.0	6.15	83.56	83.66		
	14.694	11.82	1.000	41.0	4.96	0.100	9.0	12.32	83.82			
	22.15	11.82	1.500	43.5	4.96	0.150	9.6	18.47	83.40			
28.26	11.83	1.920	44.2	4.96	0.200	9.6	23.71	83.88				
230 V AC/ 50 Hz	0.067	11.83	0.000	51.8	4.96	0.000	14.7				45.48	3.16
	0.119	12.85	0.000	23.7	4.82	0.006	46.7	0.03				
	14.41	11.74	1.000	42.2	4.97	0.060	10.9	12.04	83.54			
	7.59	11.82	0.500	31.4	4.96	0.050	9.6	6.16	81.13	83.33		
	14.76	11.82	1.000	35.8	4.96	0.100	10.2	12.32	83.44			
	21.98	11.83	1.500	39.7	4.96	0.150	9.6	18.49	84.12			
28.03	11.84	1.920	46.1	4.96	0.200	10.9	23.72	84.64				
264 V AC/ 50 Hz	0.084	11.83	0.000	51.8	4.96	0.000	14.1				47.08	3.26
	0.136	12.85	0.000	26.2	4.82	0.006	54.0	0.03				
	14.63	11.73	1.000	38.1	4.97	0.060	14.0	12.03	82.22			
	7.74	11.82	0.500	31.4	4.96	0.050	13.0	6.16	79.56	82.40		
	14.89	11.83	1.000	42.2	4.96	0.100	10.2	12.33	82.78			
	22.18	11.82	1.500	47.4	4.96	0.150	9.6	18.47	83.29			
28.23	11.83	1.920	46.7	4.96	0.200	10.2	23.71	83.97				
300 V AC/ 50 Hz	0.103	11.83	0.000	53.2	4.96	0.000	13.4				48.43	3.36
	0.154	12.91	0.000	26.9	4.82	0.006	58.0	0.03				
	14.632	11.75	1.000	42.2	4.97	0.060	10.2	12.05	82.34			
	7.892	11.82	0.500	30.7	4.96	0.050	9.6	6.16	78.03	81.40		
	15.08	11.83	1.000	37.1	4.96	0.100	9.0	12.33	81.74			
	22.39	11.82	1.500	41.0	4.96	0.150	9.0	18.47	82.51			
28.45	11.83	1.920	41.6	4.96	0.200	9.6	23.71	83.32				

Minimum load condition : 5 V at 6 mA

Typical load condition : 5 V at 60 mA and 12 V at 1 A

Maximum load condition : 5 V at 200 mA and 12 V at 1.92 A

Test results

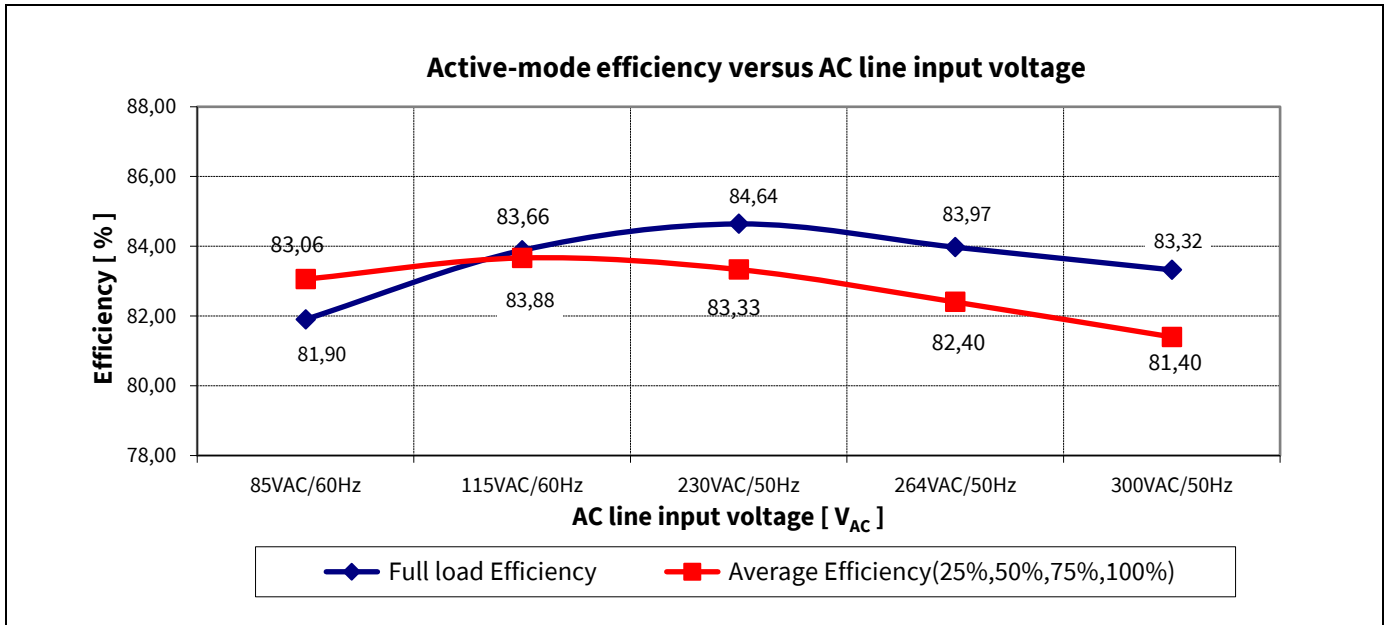

Figure 6 Efficiency vs. AC-line input voltage

10.2 Standby power

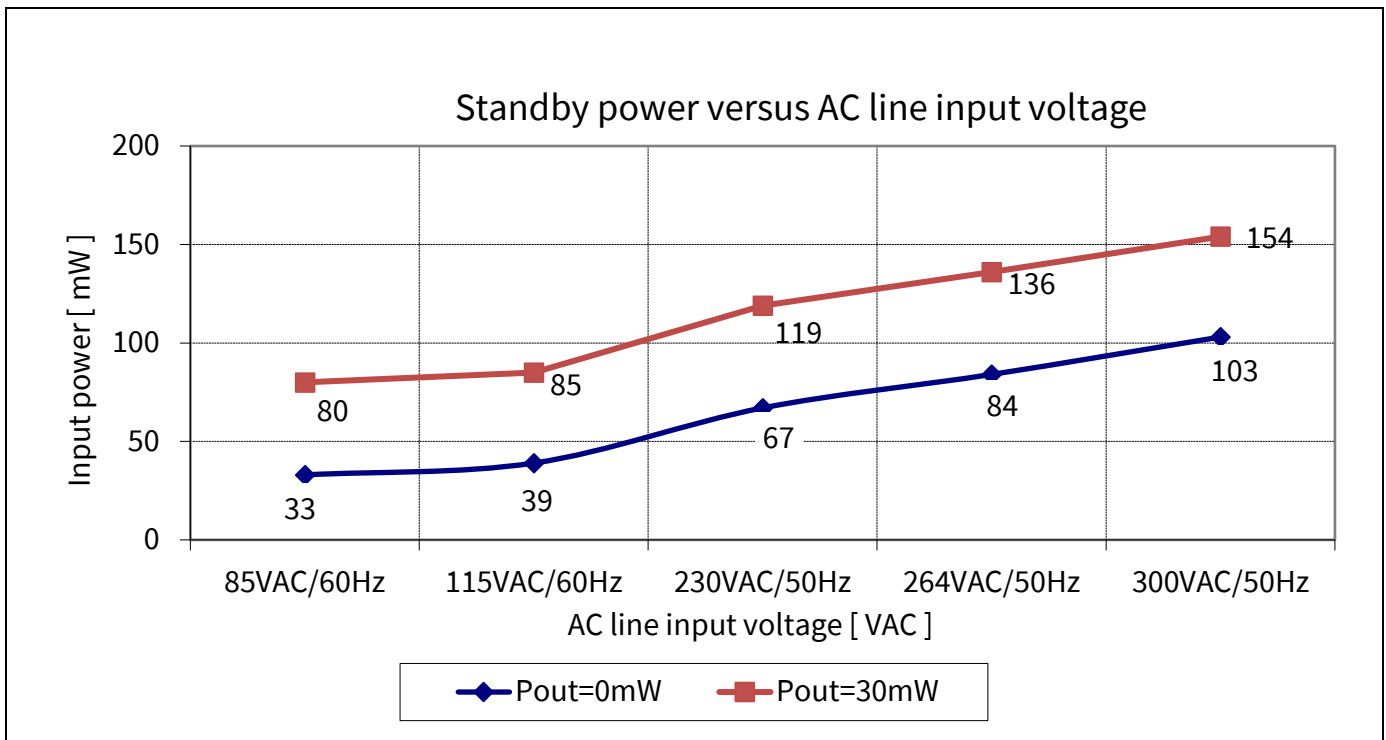

Figure 7 Standby power at no-load and 30 mW load vs. AC-line input voltage (measured by Yokogawa WT210 power meter – integration mode)

Test results

10.3 Line regulation

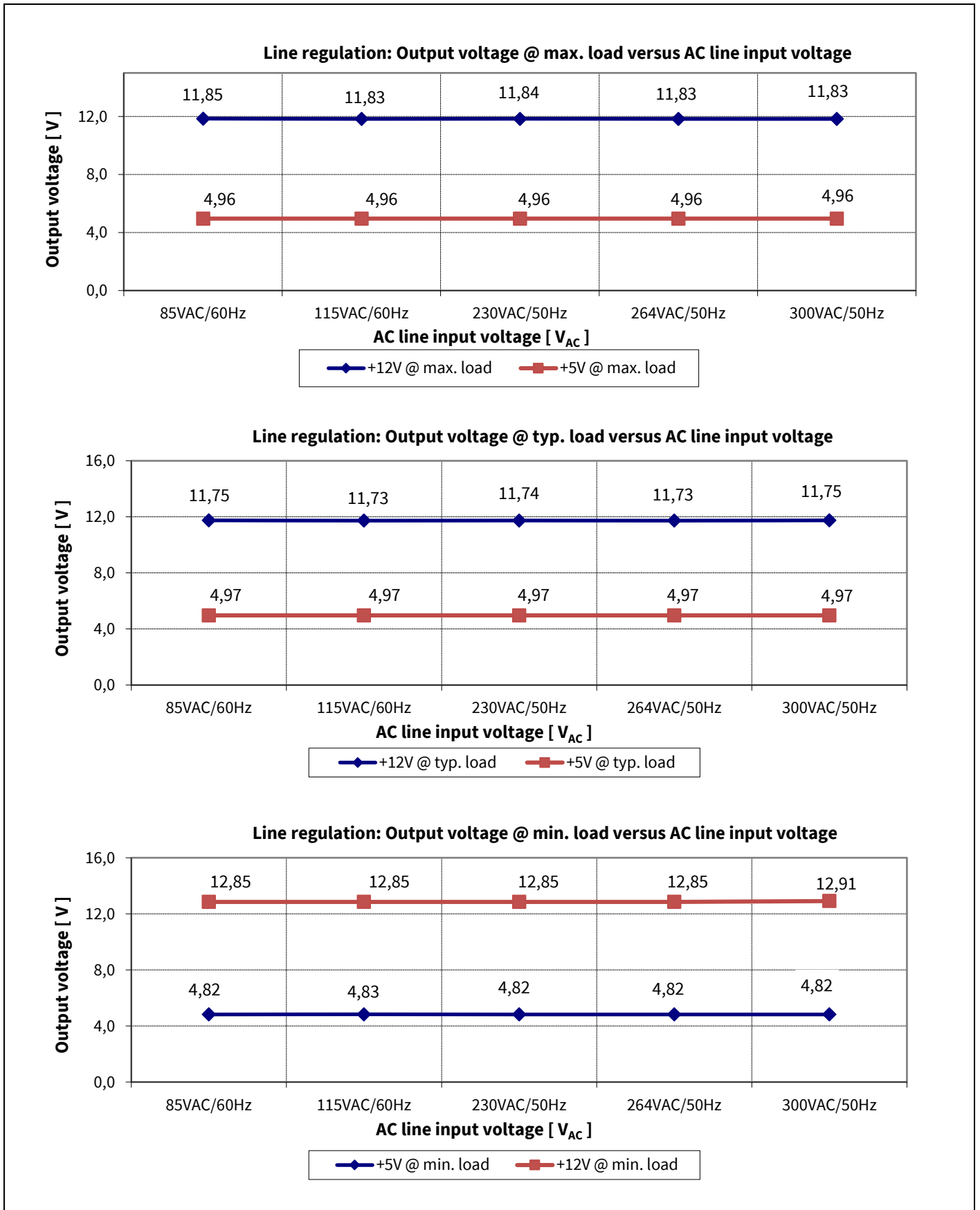

Figure 8 Line regulation V_{out} at full load vs. AC-line input voltage

Test results

10.4 Load regulation

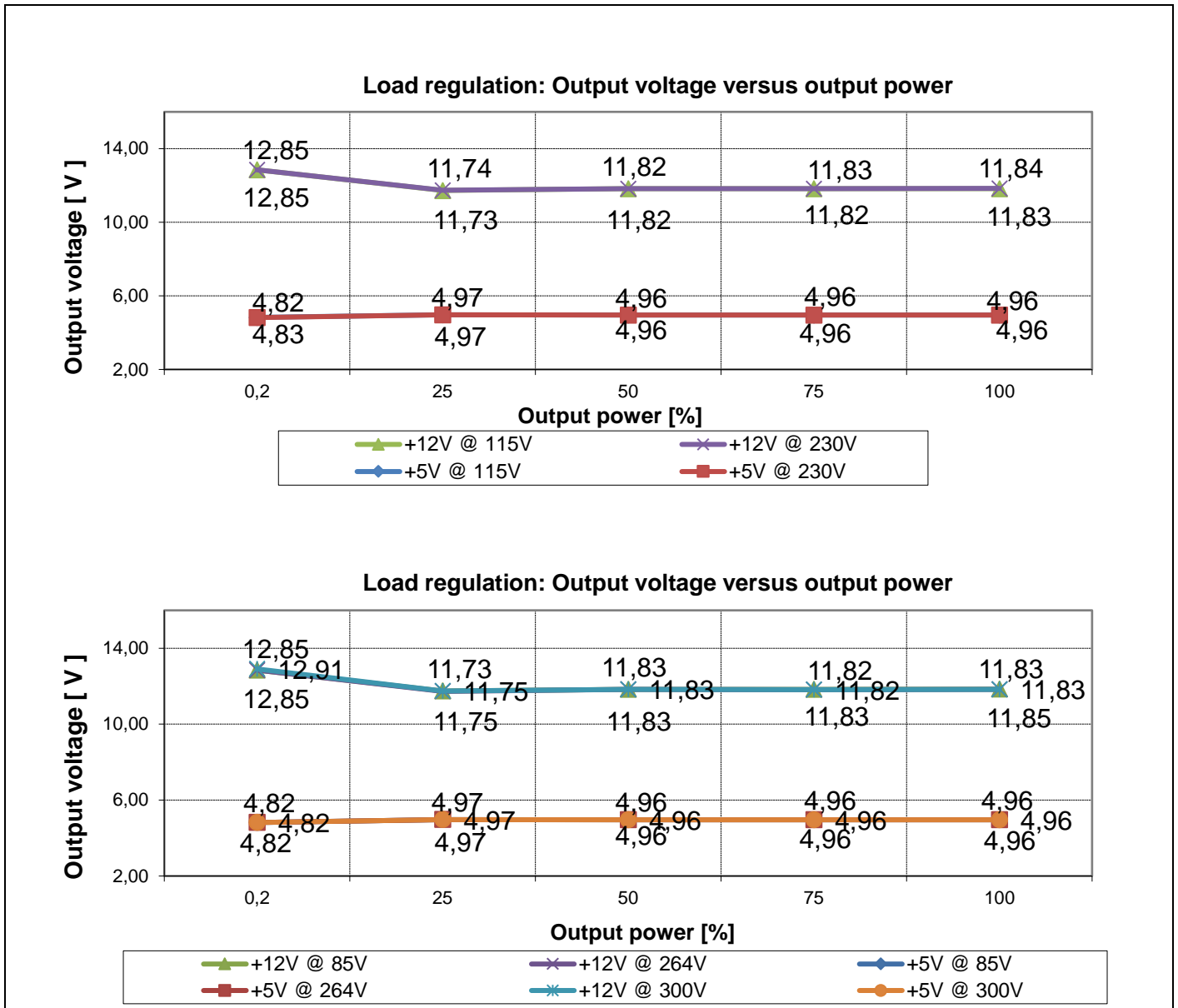

Figure 9 Load regulation V_{out} vs. output power

Test results

10.5 Maximum input power

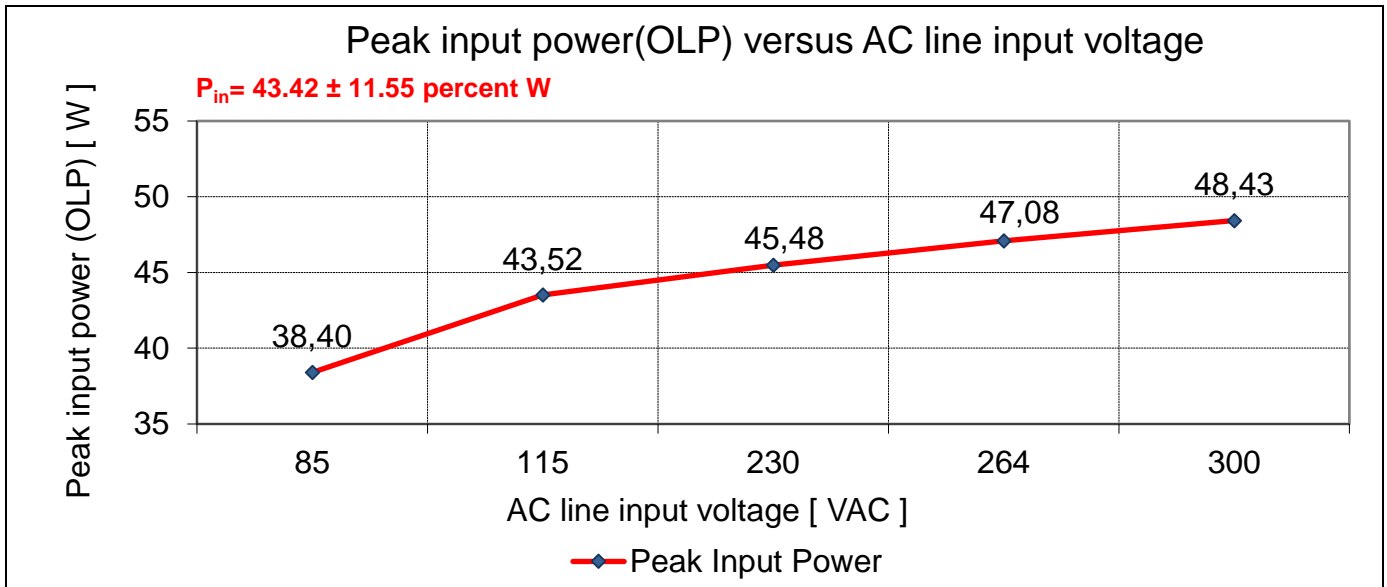

Figure 10 Maximum input power (before over-load protection) vs. AC-line input voltage

10.6 ESD immunity (EN 61000-4-2)

Pass EN 61000-4-2 special level (± 14 kV for contact discharge and ± 16 kV air discharge).

10.7 Surge immunity (EN 61000-4-5)

Pass EN 61000-4-5 installation class 4 (± 2 kV for line-to-line and ± 4 kV for line-to-earth).¹

10.8 Conducted emissions (EN 55022 class B)

The conducted EMI was measured by Schaffner (SMR4503) and followed the test standard of EN 55022 (CISPR 22) class B. The demo board was set up at maximum load (24 W) with input voltage of 115 V AC and 230 V AC.

¹ PCB spark-gap distance needs to reduce to 0.5 mm and C1 change to 120 μ F.

Test results

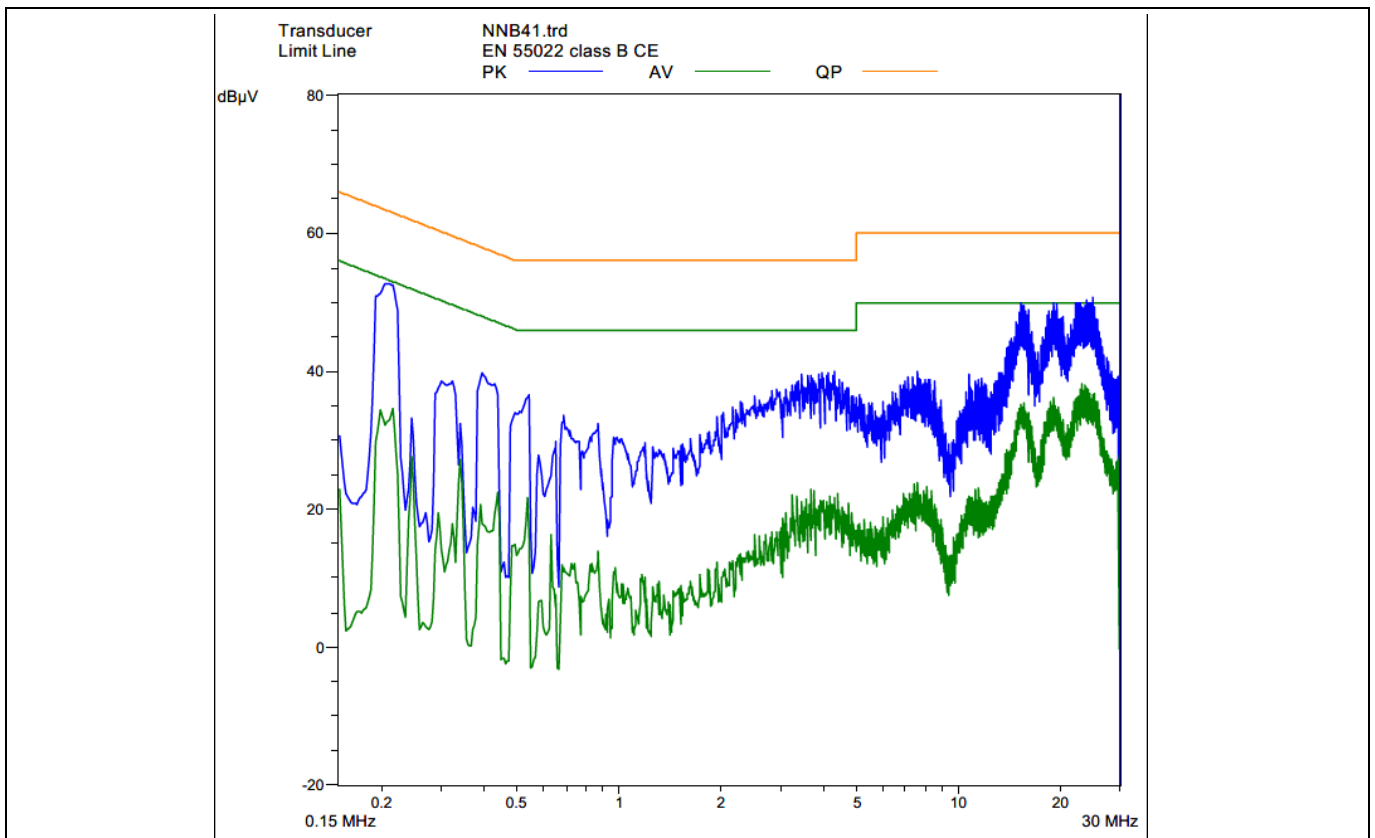

Figure 11 Conducted emissions (line) at 115 V AC and maximum load

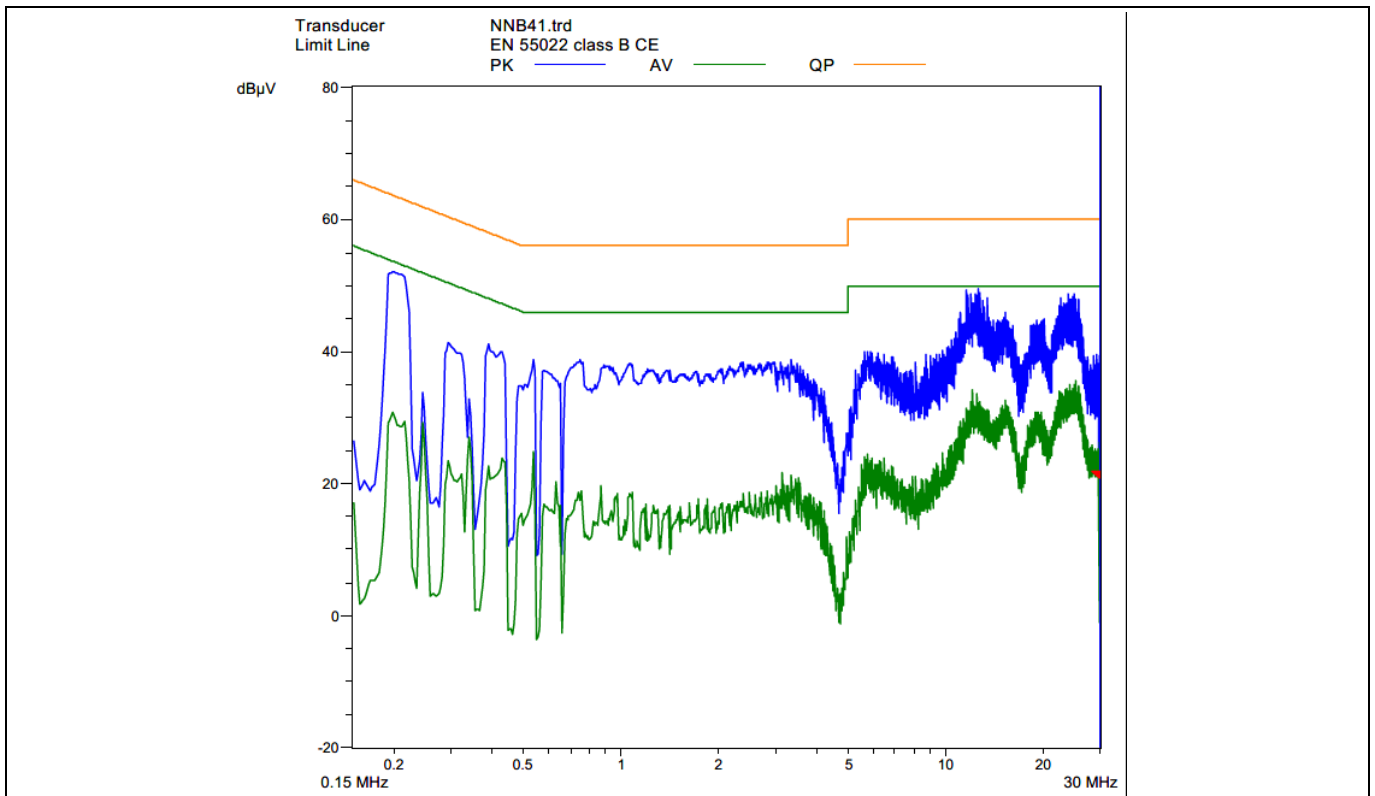

Figure 12 Conducted emissions (neutral) at 115 V AC and maximum load

Pass conducted emissions EN 55022 (CISPR 22) class B with 10 dB margin for quasi-peak measurement at low-line (115 V AC).

Test results

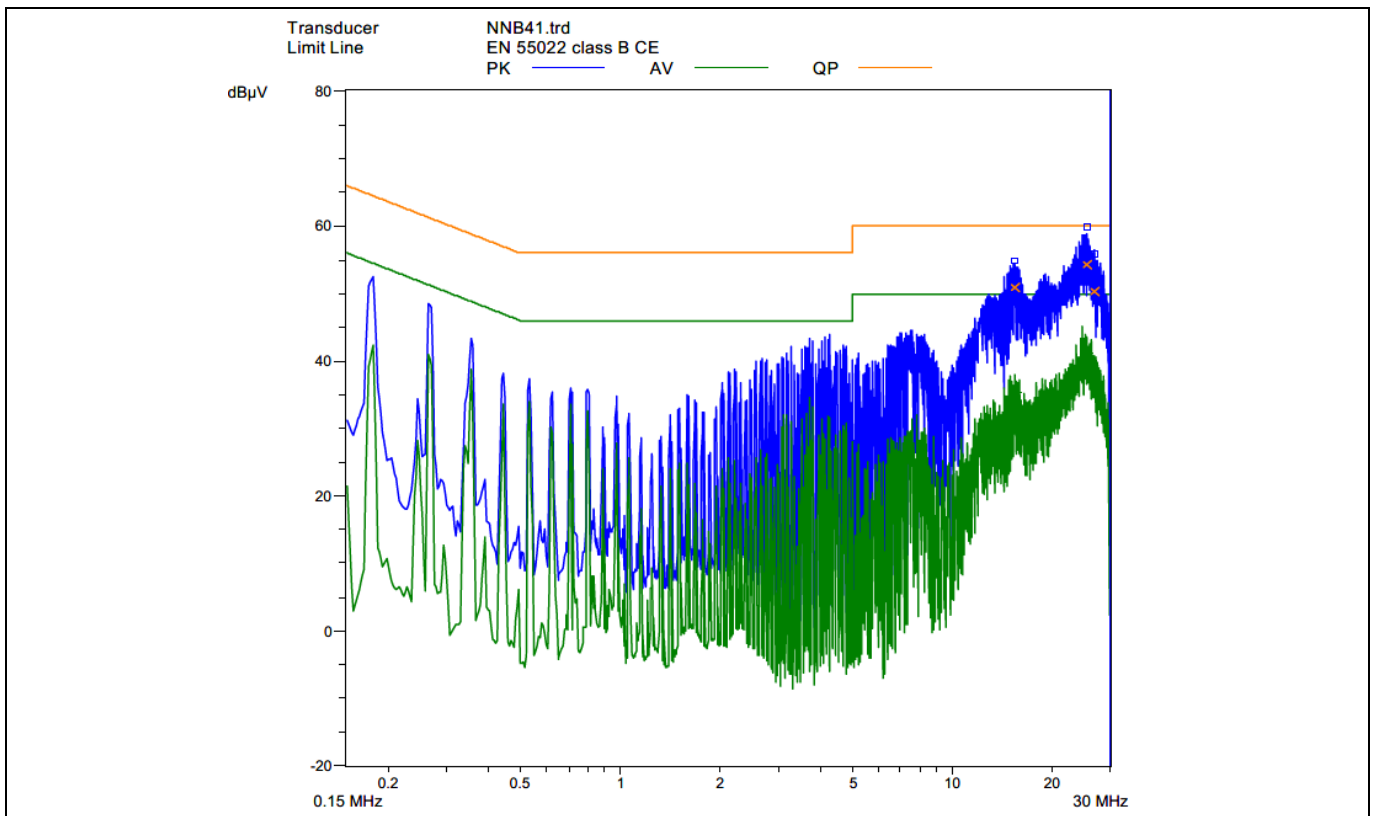

Figure 13 Conducted emissions (line) at 230 V AC and maximum load

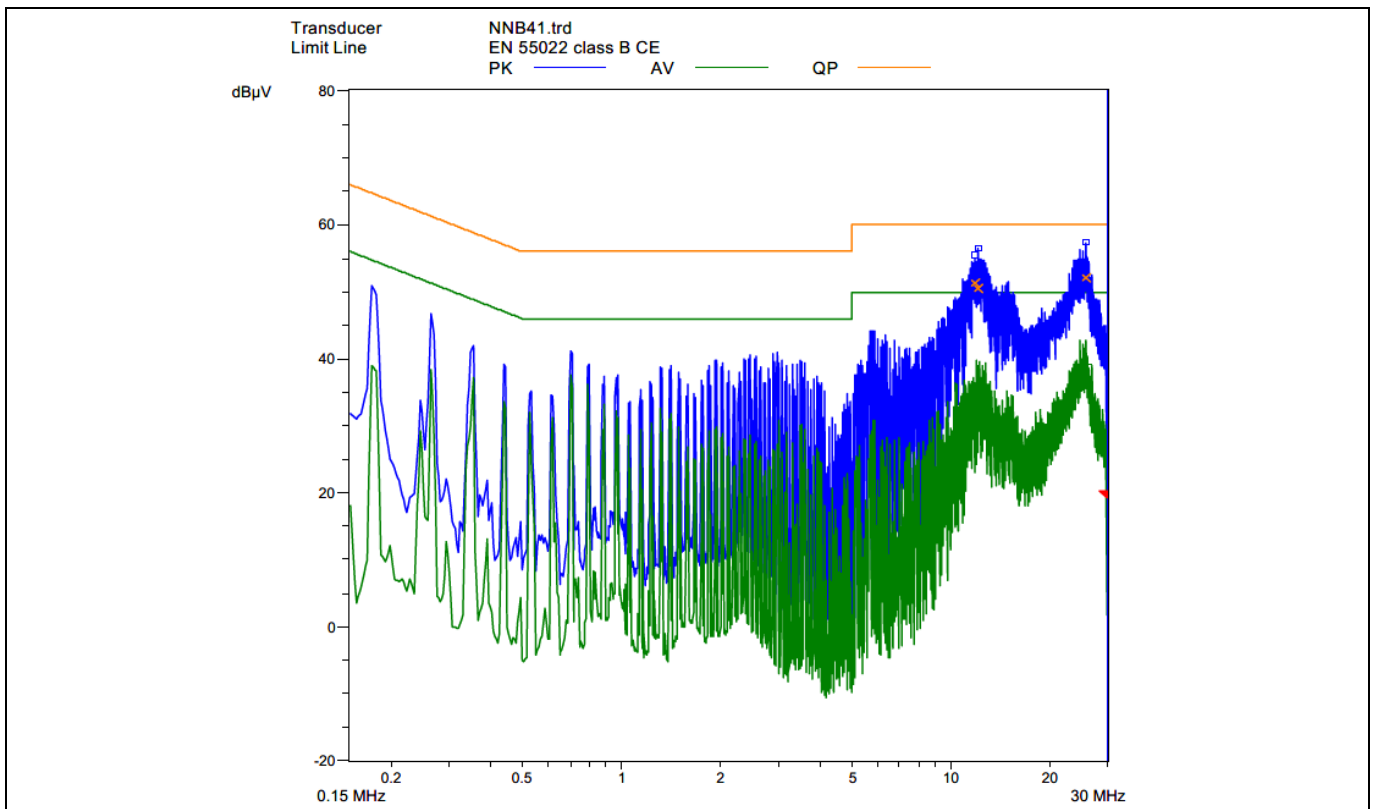

Figure 14 Conducted emissions (neutral) at 230 V AC and maximum load

Pass conducted emissions EN 55022 (CISPR 22) class B with 6 dB margin for quasi-peak measurement at high-line (230 V AC).

Test results

10.9 Thermal measurement

The thermal test of the open-frame demo board was done using an infrared thermography camera (FLIR-T420) at an ambient temperature of 25°C. The measurements were taken after one hour running at full load.

Table 5 Hottest temperature of demo board

No.	Major component	85 V AC (°C)	300 V AC (°C)
1	TR1 (transformer)	58.1	64.1
2	D21 (secondary diode)	75.4	74.6
3	IC11 (ICE5QR2280BG)	86.2	90.6
4	L11 (choke)	62.2	35.2
5	Ambient	25.0	25.0

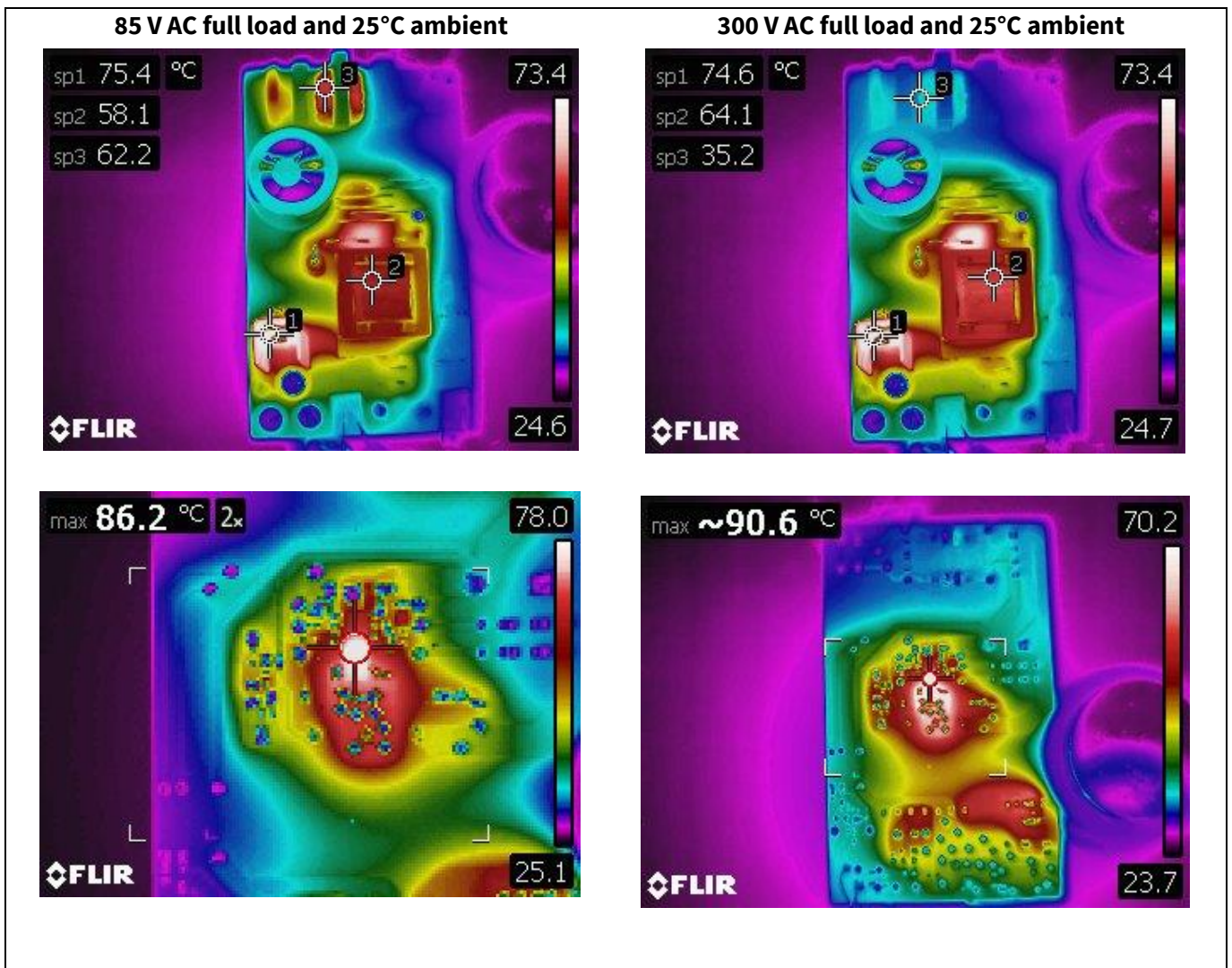

Figure 15 Infrared thermal image of DEMO_5QR2280BG_24W1

Waveforms and scope plots

11 Waveforms and scope plots

All waveforms and scope plots were recorded with a Teledyne LeCroy 44Xi oscilloscope.

11.1 Start-up at low/high AC-line input voltage with maximum load

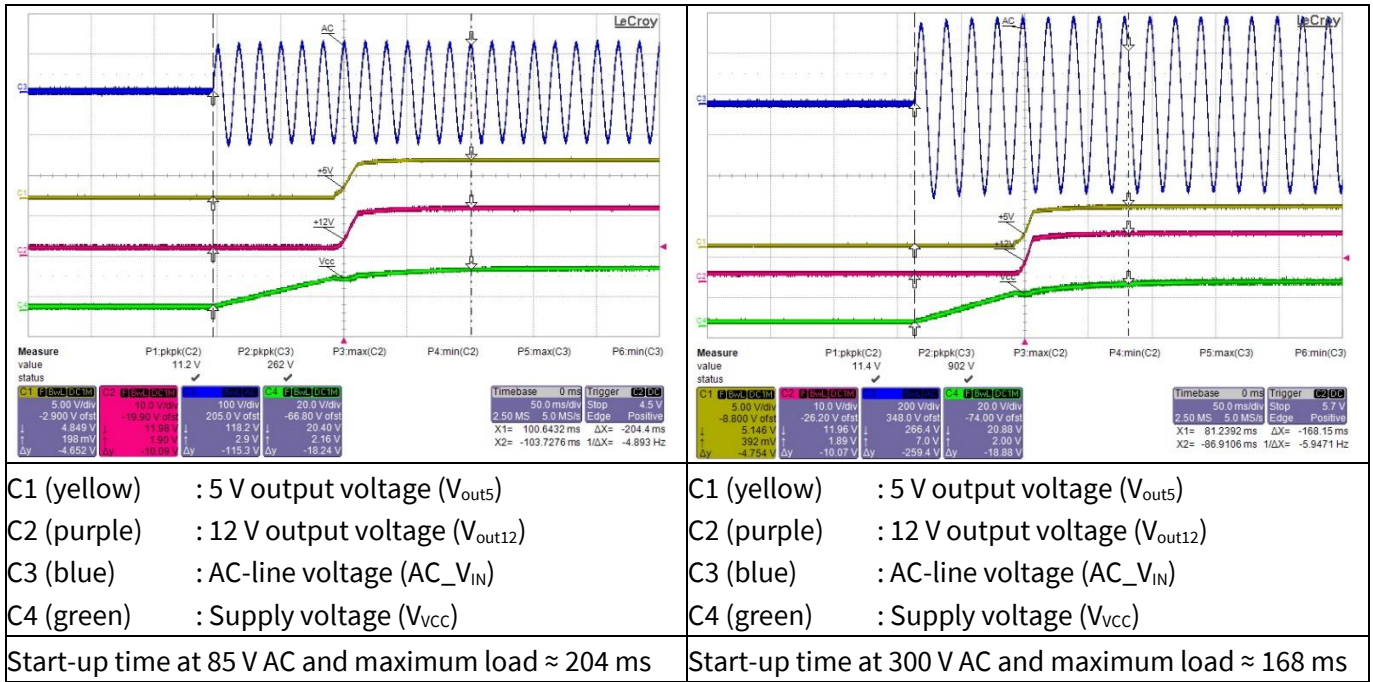

Figure 16 Start-up

11.2 Soft-start

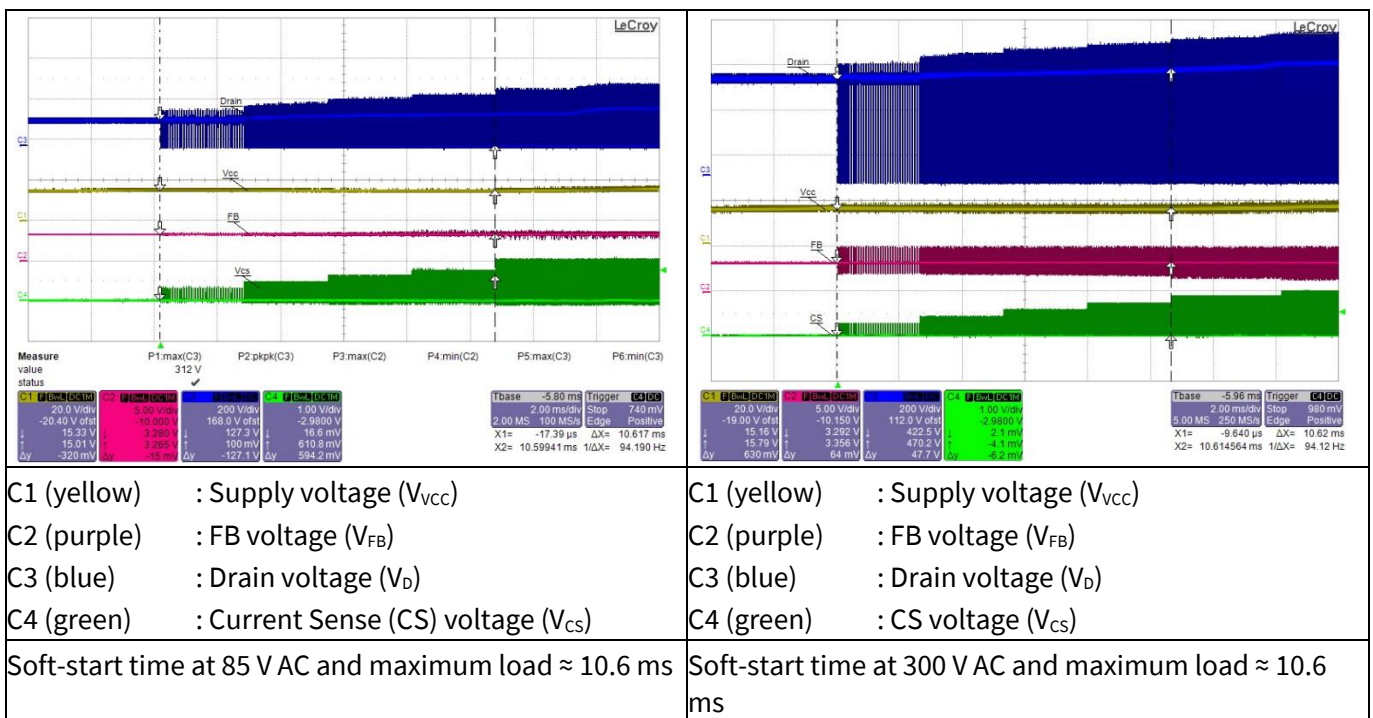

Figure 17 Soft-start

Waveforms and scope plots

11.3 Drain and CS voltage at maximum load

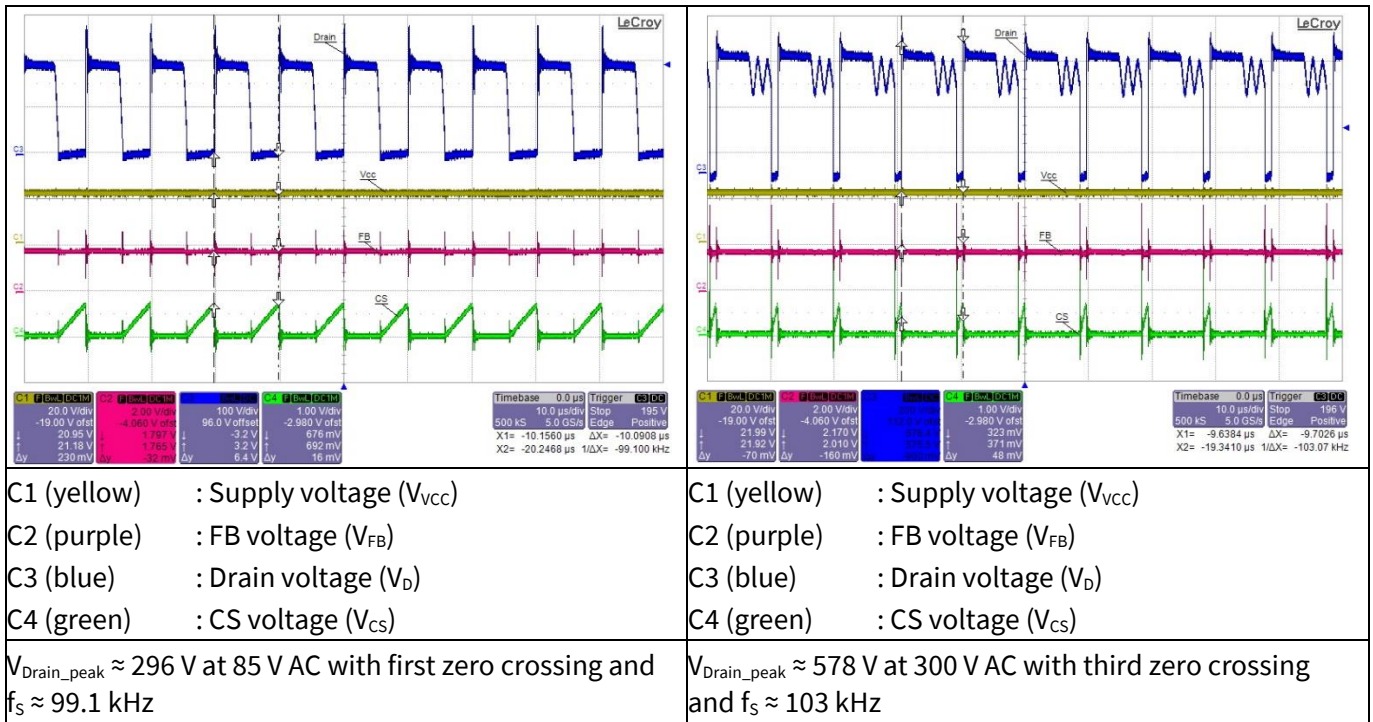

Figure 18 Drain and CS voltage at maximum load

11.4 Zero crossing point during normal operation

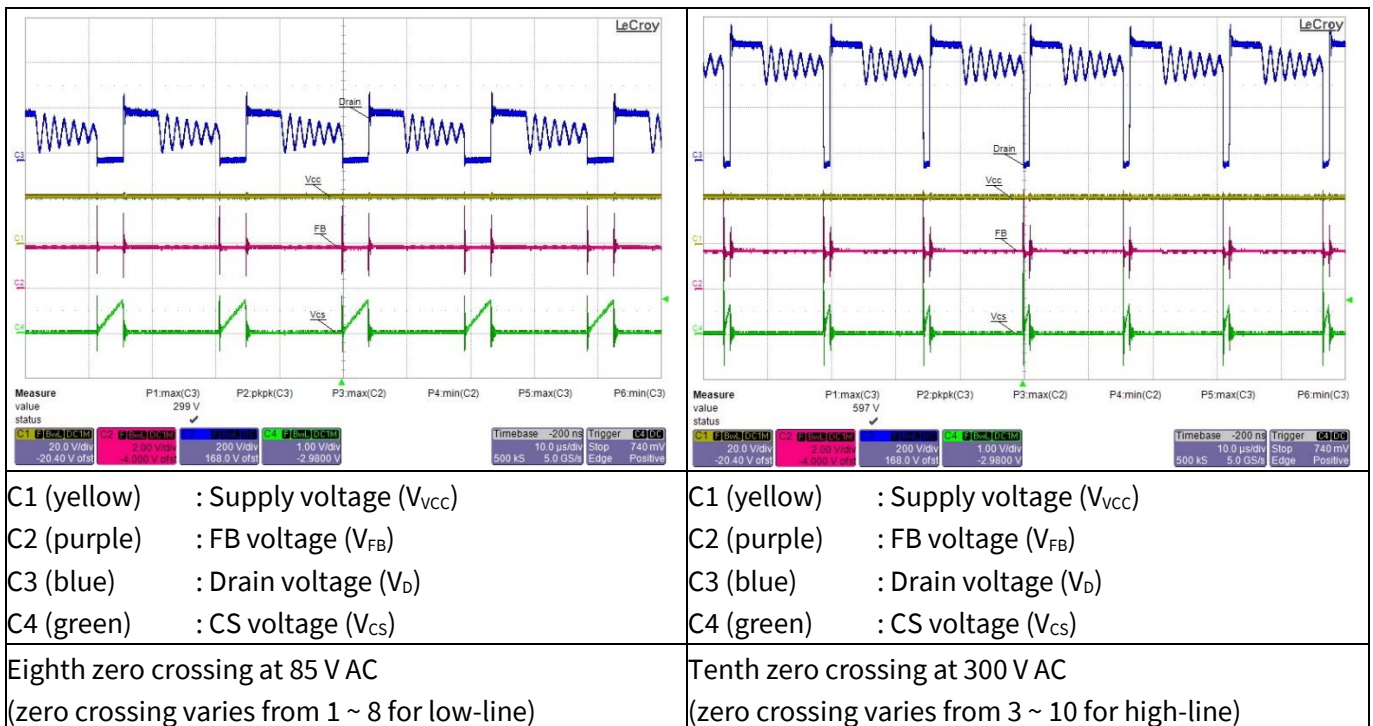

Figure 19 Zero crossing

Waveforms and scope plots

11.5 Load-transient response (dynamic load from 10 percent to 100 percent)

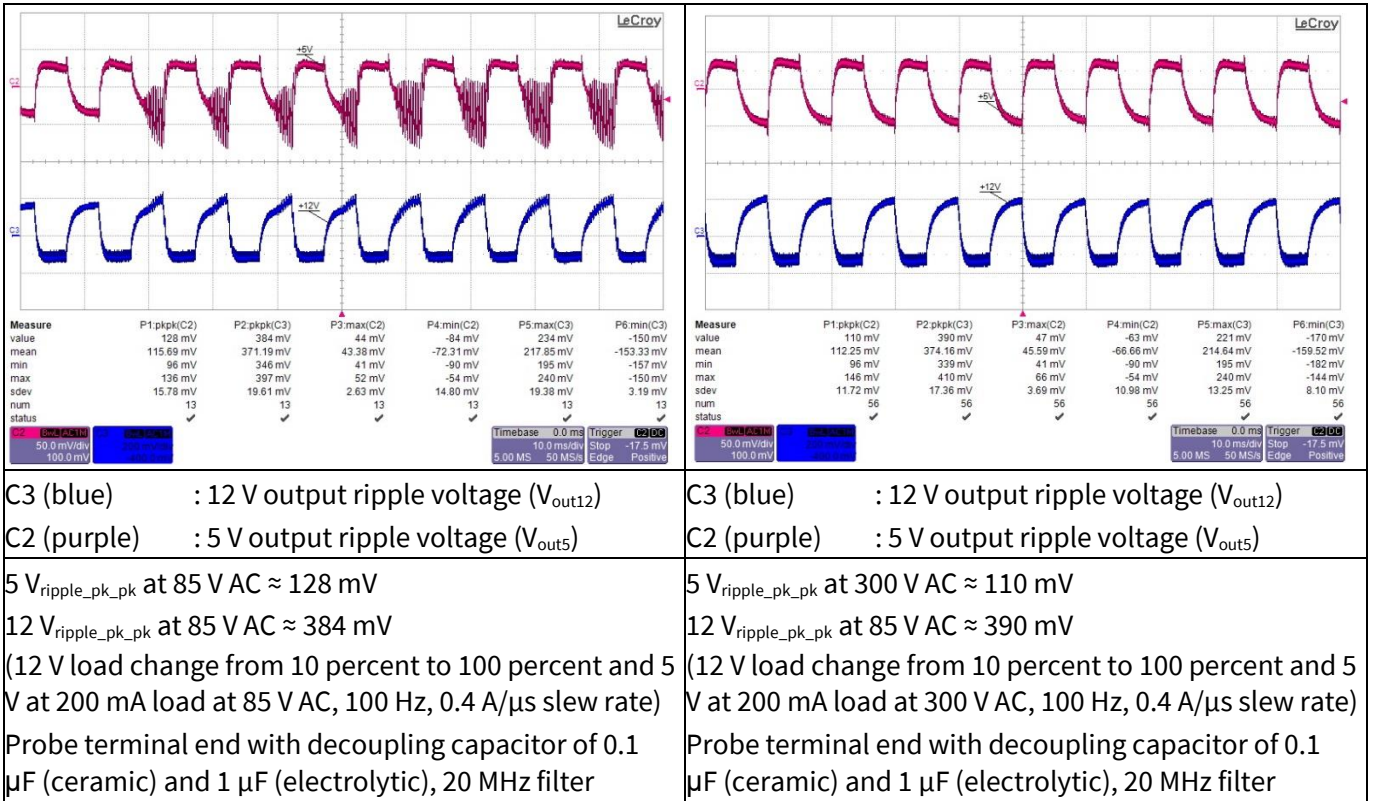

Figure 20 Load transient response

11.6 Output ripple voltage at maximum load

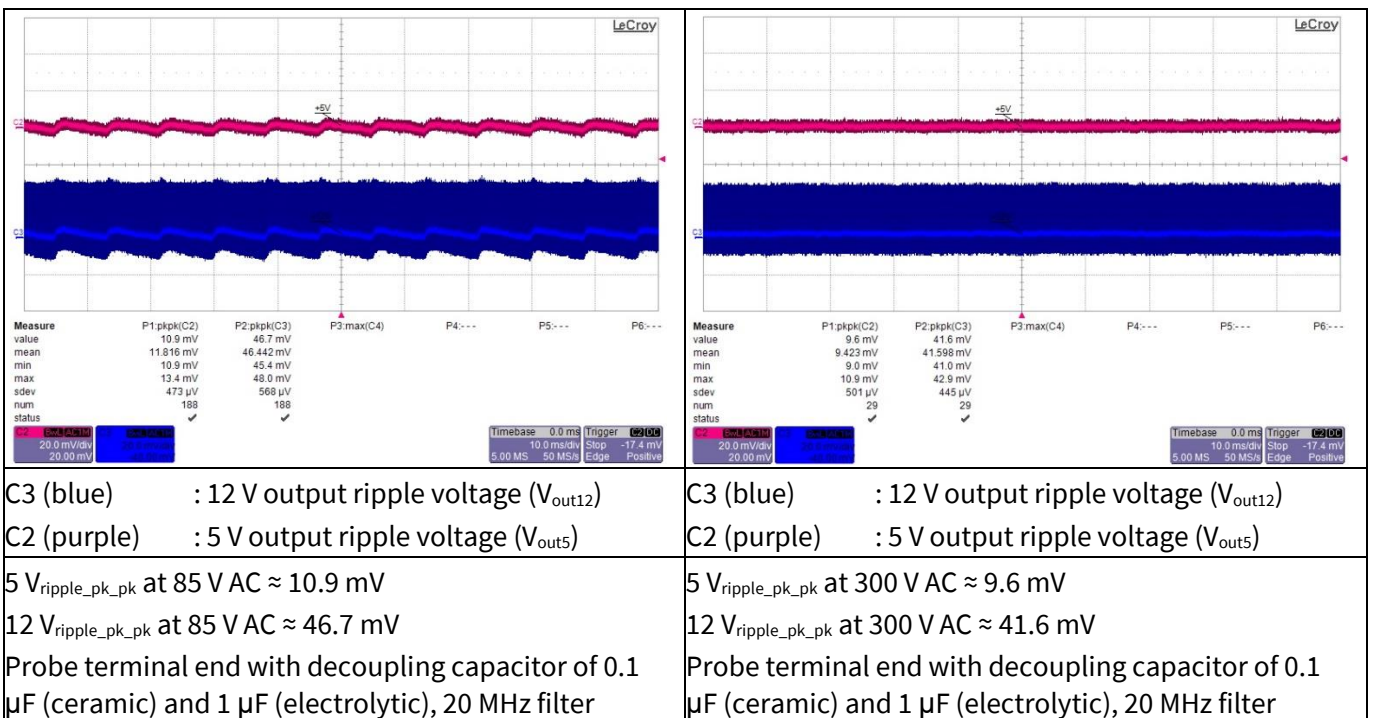

Figure 21 Output ripple voltage at maximum load

Waveforms and scope plots

11.7 Output ripple voltage at ABM 1 W load

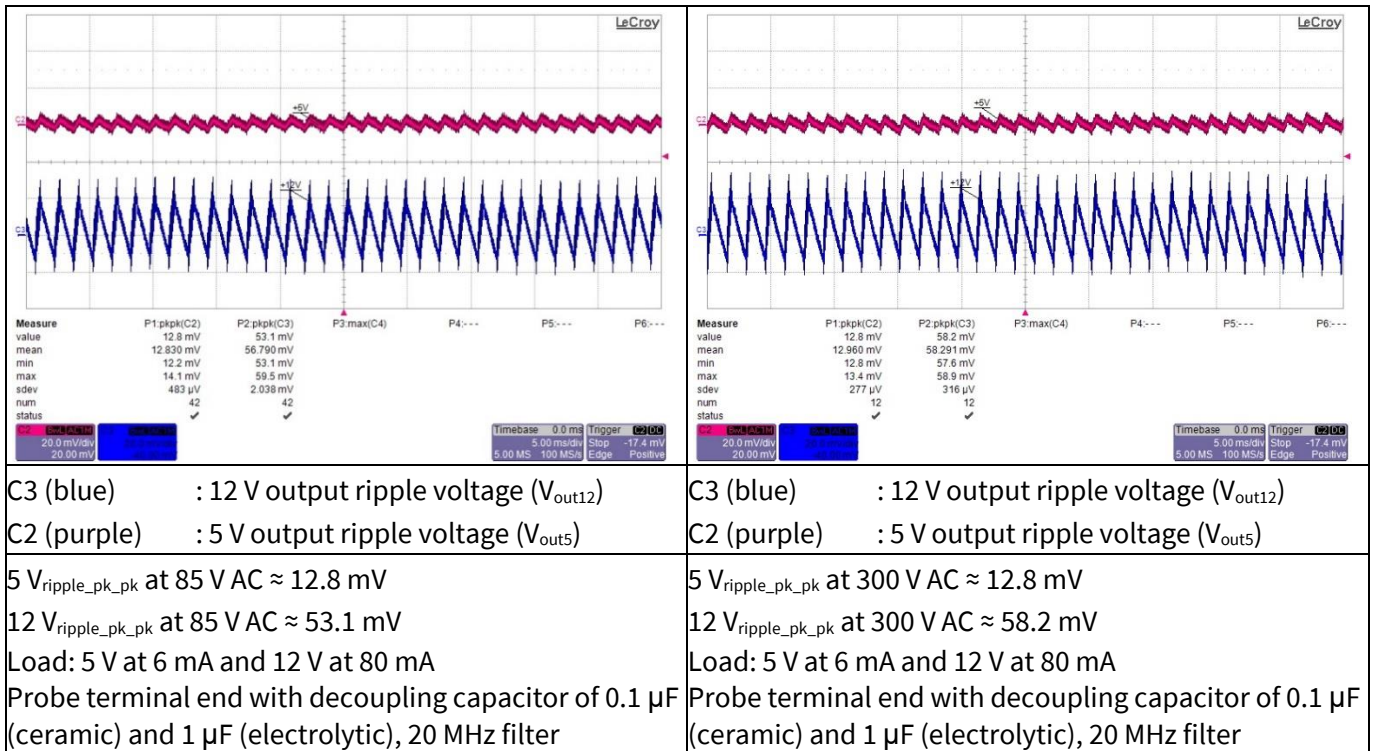

Figure 22 Output ripple voltage at ABM 1 W load

11.8 Entering ABM

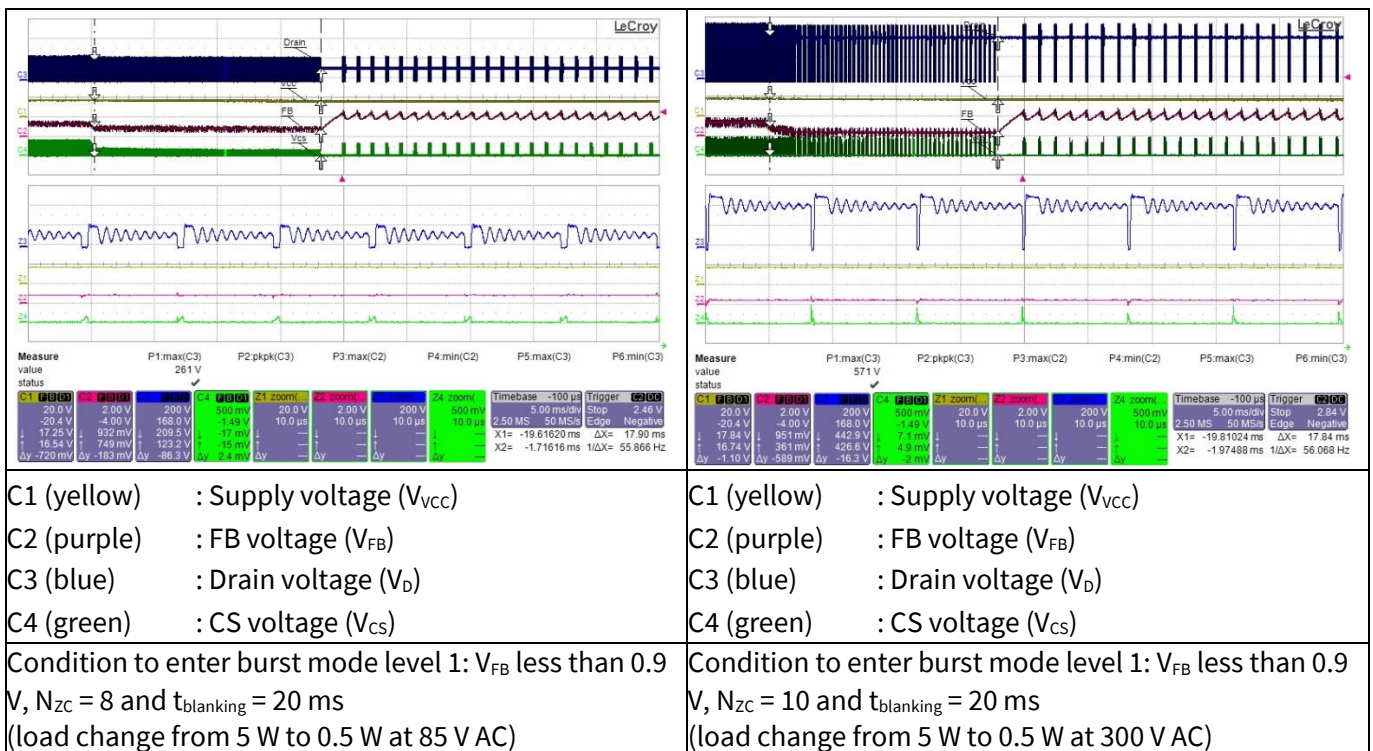

Figure 23 Entering ABM

Waveforms and scope plots

11.9 During ABM

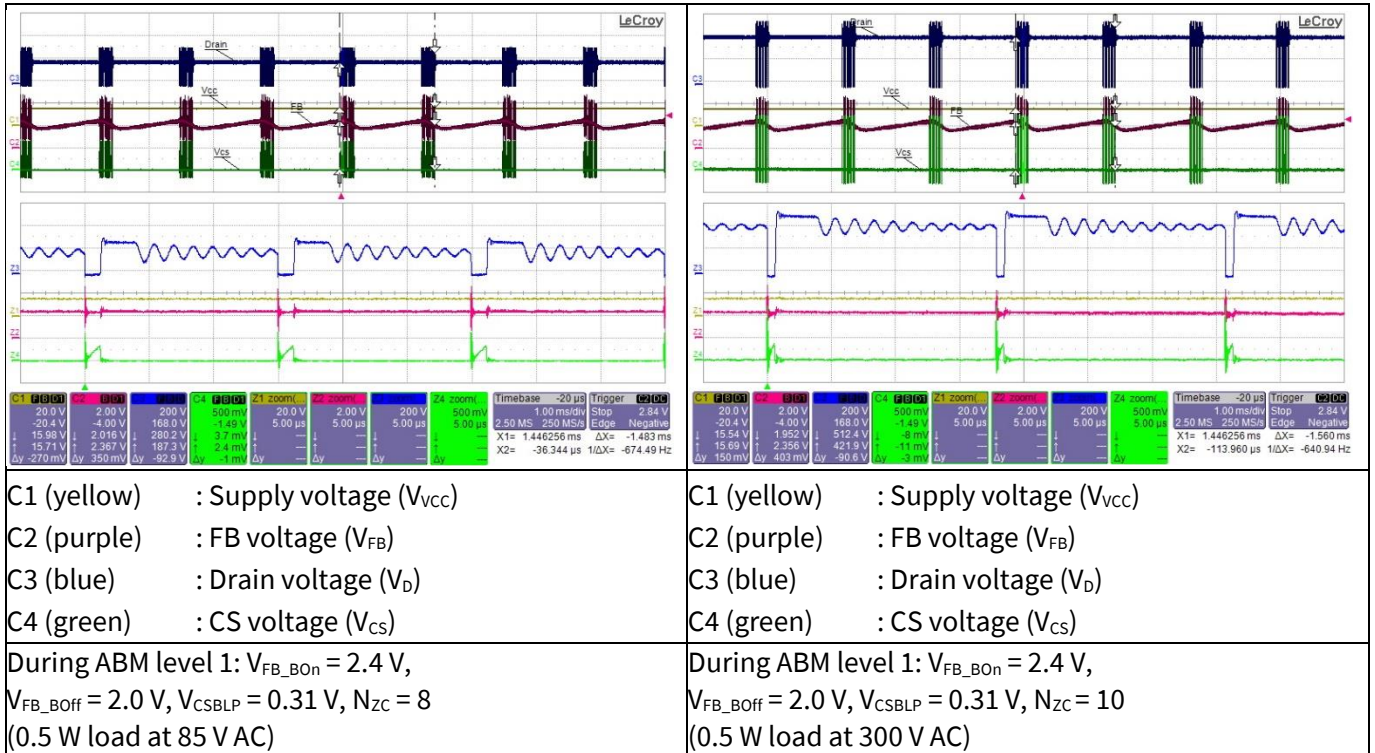

Figure 24 During ABM

11.10 Leaving ABM

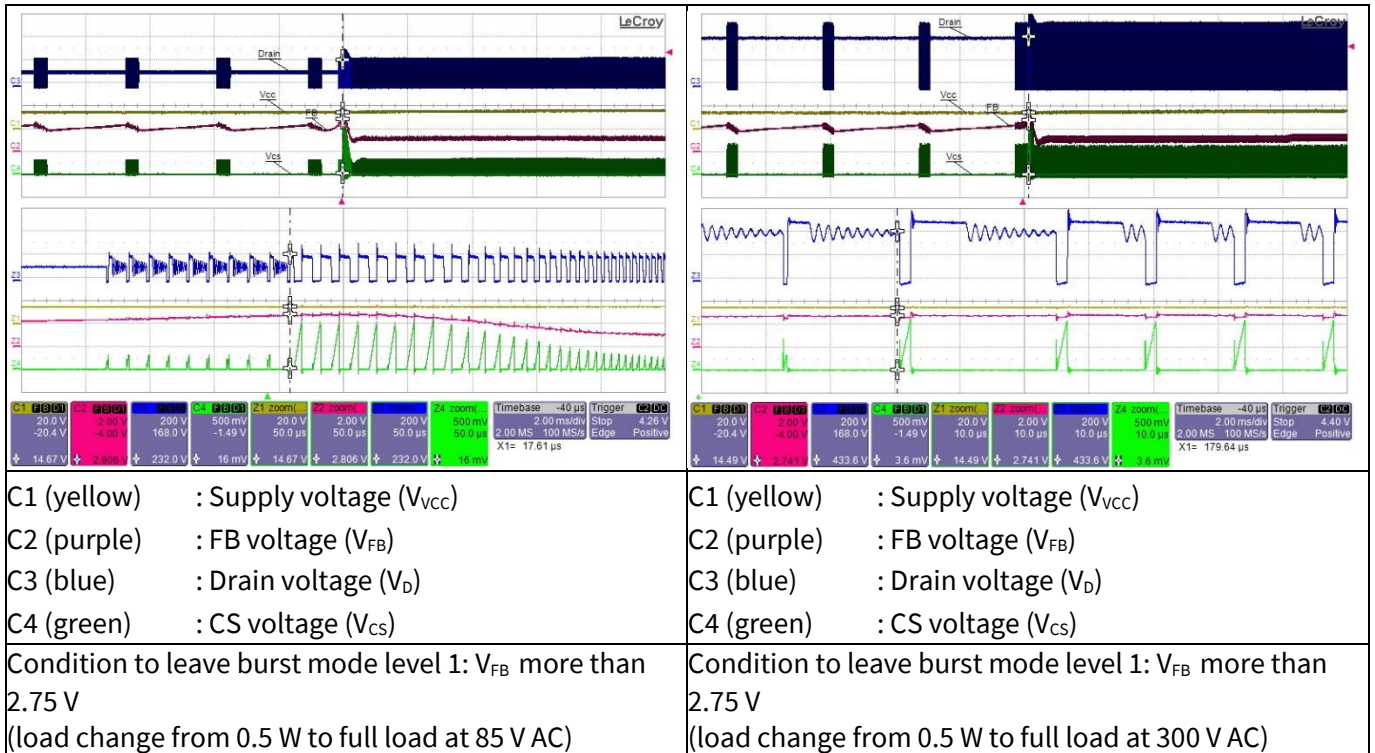

Figure 25 Leaving ABM

Waveforms and scope plots

11.11 Line OVP (non-switch auto-restart)

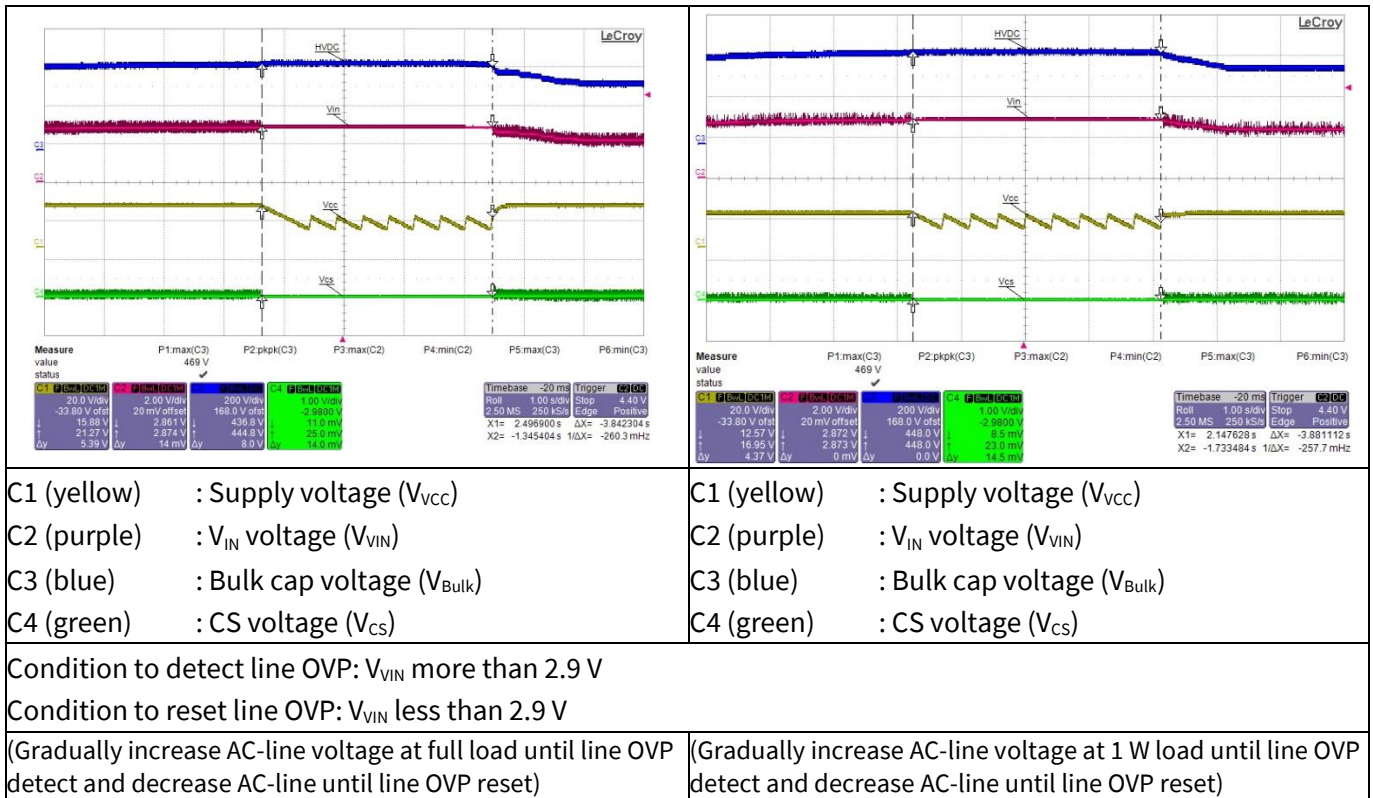

Figure 26 Line OVP

11.12 Brown-out protection (non-switch auto-restart)

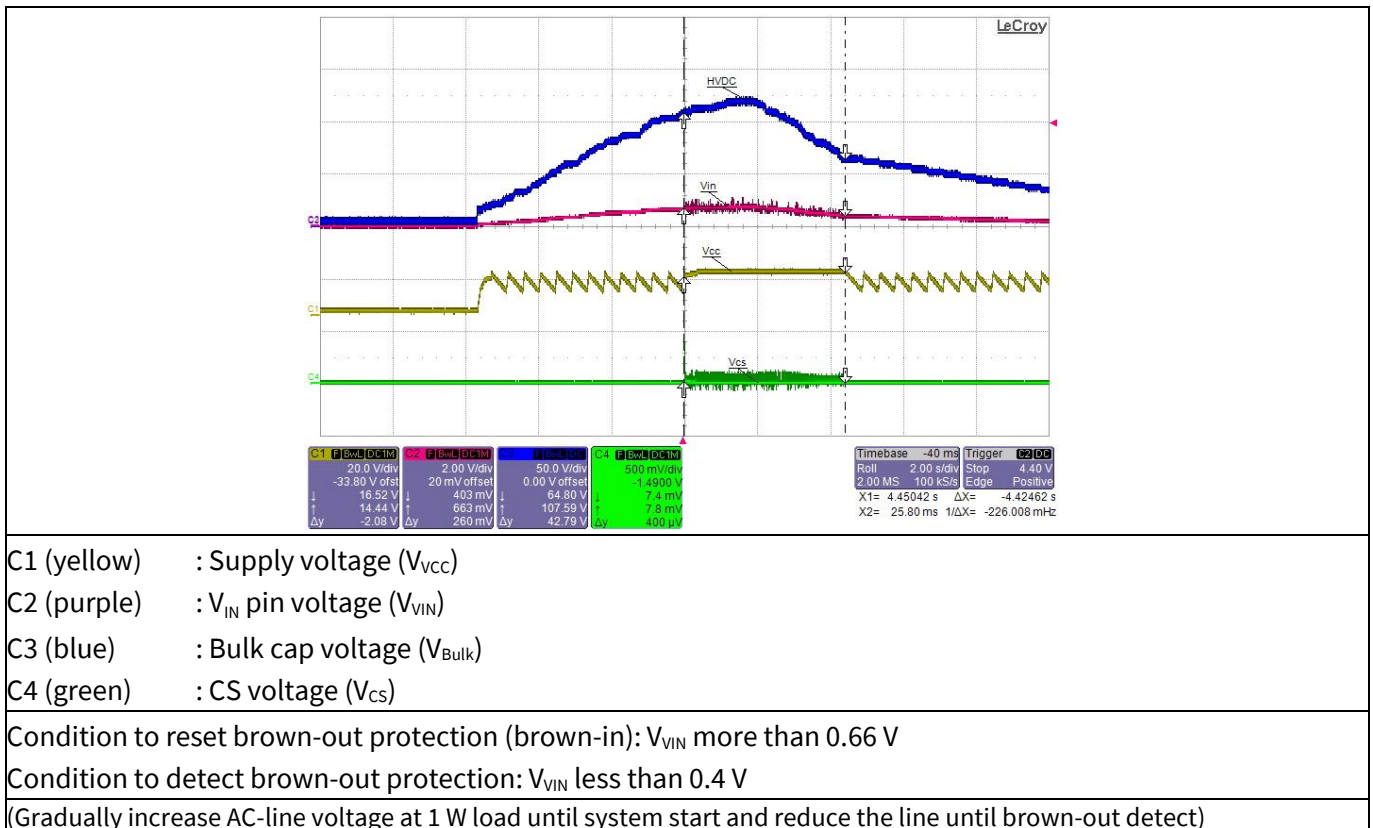
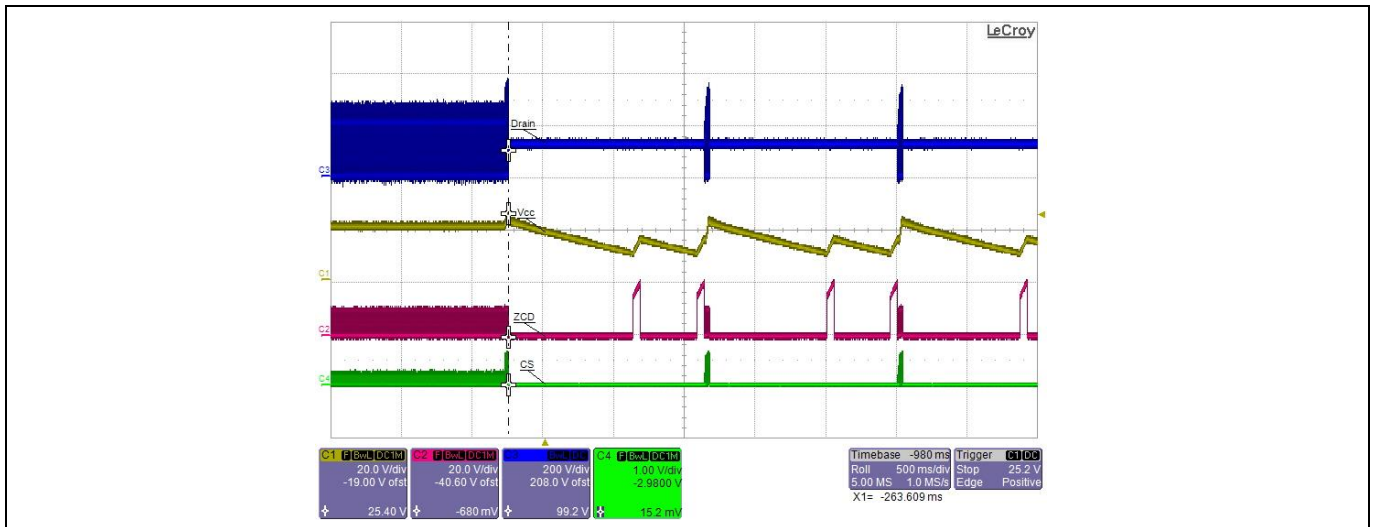

Figure 27 Brown-out protection

Waveforms and scope plots

11.13 V_{CC} OVP (odd-skip auto restart)



- C1 (yellow) : Supply voltage (V_{CC})
- C2 (purple) : Zero crossing detection voltage (V_{ZCD})
- C3 (blue) : Drain voltage (V_D)
- C4 (green) : CS voltage (V_{CS})

Condition to enter V_{CC} OVP: V_{CC} more than 25.5 V
 (85 V AC and disable ZCD pin output OVP detection, short R26)

Figure 28 V_{CC} OVP

11.14 V_{CC} Under-Voltage Protection (UVP) (auto-restart)

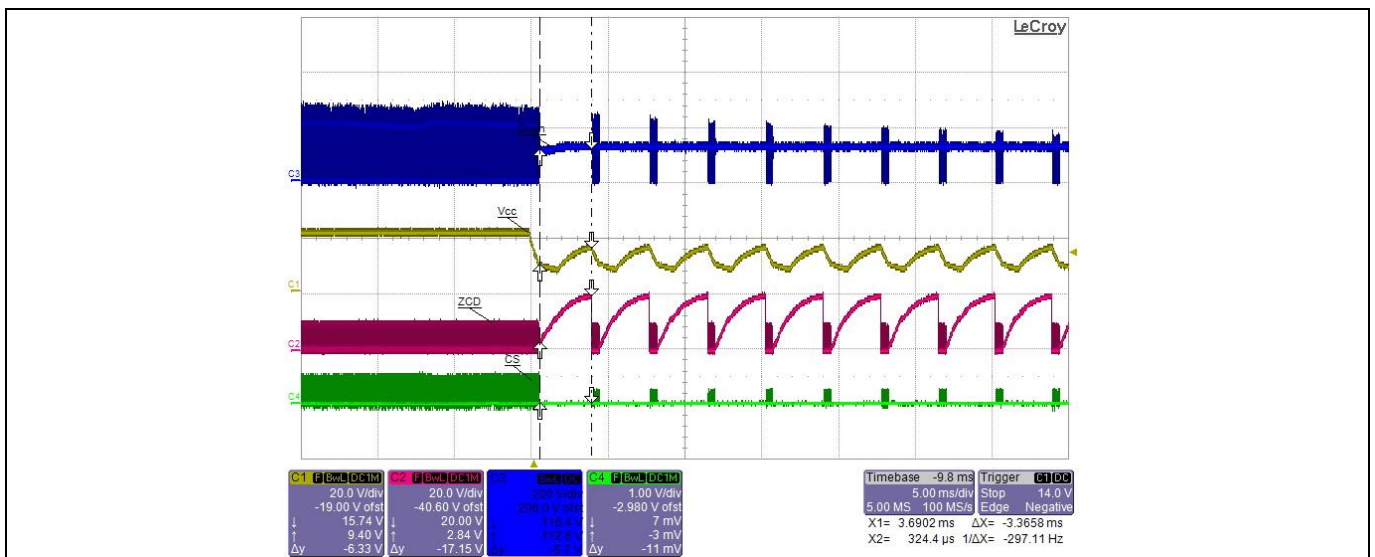

- C1 (yellow) : Supply voltage (V_{CC})
- C2 (purple) : Zero crossing detection voltage (V_{ZCD})
- C3 (blue) : Drain voltage (V_D)
- C4 (green) : CS voltage (V_{CS})

Condition to enter V_{CC} UVP: V_{CC} less than 10 V
 (Remove R6 during normal operation at 85 V AC)

Figure 29 V_{CC} UVP

Waveforms and scope plots

11.15 Over-load protection (odd-skip auto-restart)

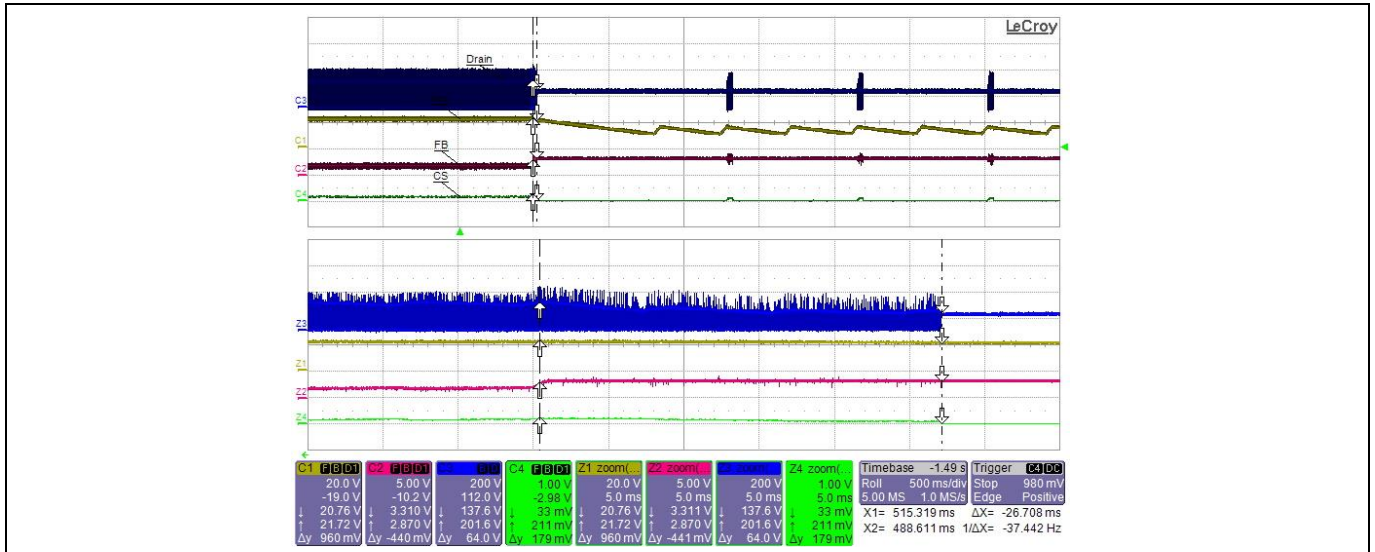

- C1 (yellow) : Supply voltage (V_{VCC})
- C2 (purple) : FB voltage (V_{FB})
- C3 (blue) : Drain voltage (V_D)
- C4 (green) : CS voltage (V_{CS})

Condition to enter over-load protection: V_{FB} more than 2.75 V and lasts for 30 ms blanking time (12 V output load change from full load to short at 85 V AC)

Figure 30 OVP

11.16 Output OVP (odd-skip auto-restart)

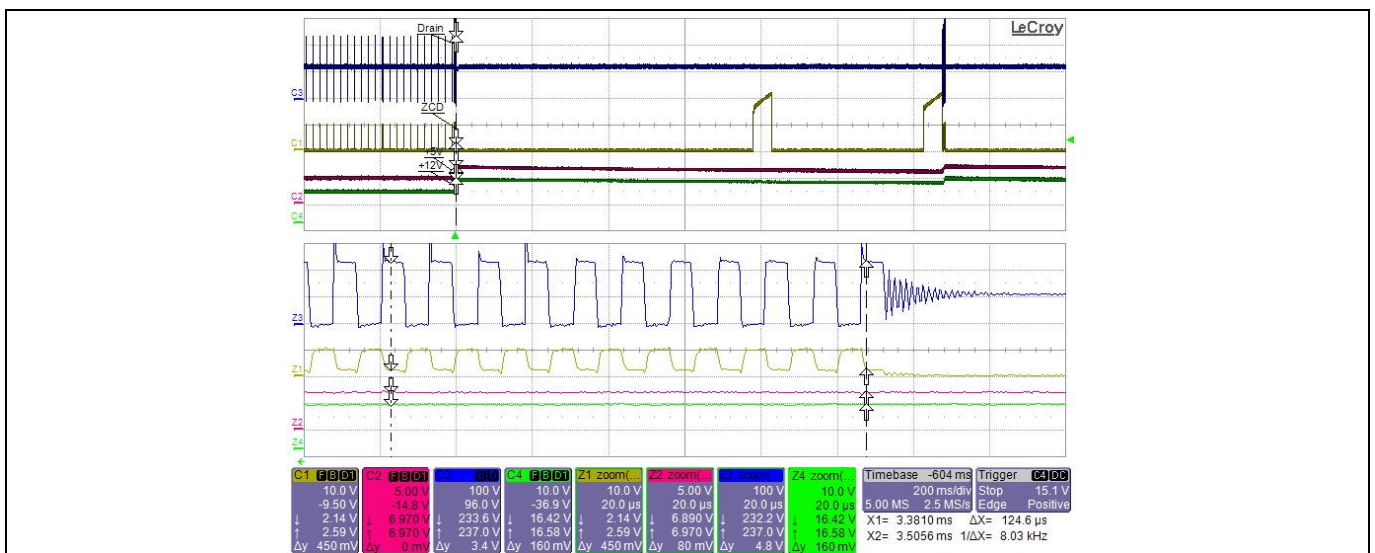

- C1 (yellow) : 12 V output voltage (V_{O12})
- C2 (purple) : 5 V output voltage (V_{O5})
- C3 (blue) : Zero crossing detection voltage (V_{ZCD})
- C4 (green) : CS voltage (V_{CS})

Condition to enter output OVP: V_{O12} more than 17 V, V_{O5} more than 7 V (V_{ZCD} more than 2 V) (85 V AC, short R21A during system operation at no load)

Figure 31 Output OVP

Waveforms and scope plots

11.17 V_{CC} short-to-GND protection

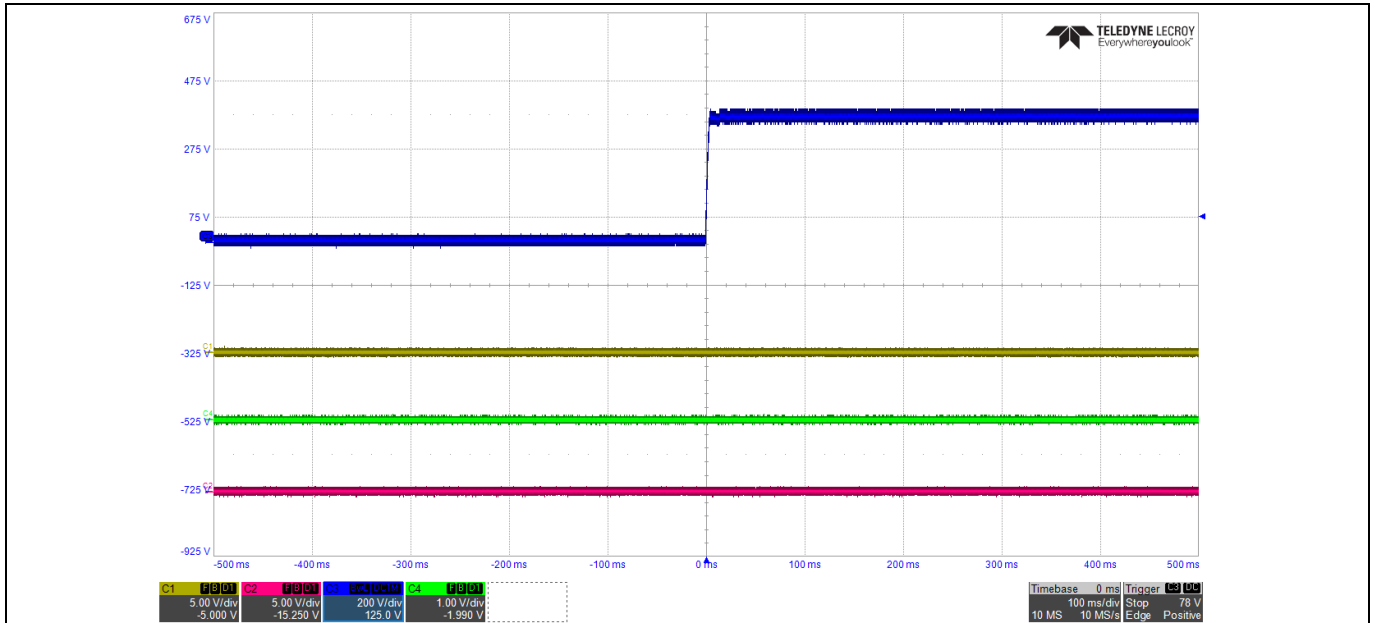

- C1 (yellow) : V_{CC} voltage (V_{VCC})
- C2 (purple) : Zero crossing detection voltage (V_{ZCD})
- C3 (blue) : Drain voltage (V_D)
- C4 (green) : CS voltage (V_{CS})

Condition to enter V_{CC} short-to-GND: if V_{CC} is less than $\rightarrow V_{VCC_SCP} I_{VCC} = I_{VCC_Charge1}$
 (Short V_{CC} pin-to-GND and measure the AC input current, I_{in} ≈ 24.4 mA and input power is ≈ 40.2 mW at 264 V AC)

Figure 32 V_{CC} short-to-GND protection

12 References

- [1] [ICE5QRxx80BG datasheet, Infineon Technologies AG](#)
- [2] [AN-201609_PL83_026-fifth-generation QR Design Guide](#)
- [3] [Calculation Tool Quasi-Resonant CoolSET™ Generation 5](#)

Revision history

Revision history

Document version	Date of release	Description of changes
V1.0	13-03-2020	First release

Trademarks of Infineon Technologies AG

AURIX™, C166™, CanPAK™, CIPOS™, CoolGaN™, CoolMOS™, CoolSET™, CoolSiC™, CORECONTROL™, CROSSAVE™, DAVE™, DI-POL™, DrBlade™, EasyPIM™, EconoBRIDGE™, EconoDUAL™, EconoPACK™, EconoPIM™, EiceDRIVER™, eupec™, FCOS™, HITFET™, HybridPACK™, Infineon™, ISOFACE™, IsoPACK™, i-Wafer™, MIPAQ™, ModSTACK™, my-d™, NovalithIC™, OmniTune™, OPTIGA™, OptiMOS™, ORIGA™, POWERCODE™, PRIMARION™, PrimePACK™, PrimeSTACK™, PROFET™, PRO-SIL™, RASIC™, REAL3™, ReverSave™, SatRIC™, SIEGET™, SIPMOS™, SmartLEWIS™, SOLID FLASH™, SPOC™, TEMPFET™, thinQ!™, TRENCHSTOP™, TriCore™.

Trademarks updated August 2015

Other Trademarks

All referenced product or service names and trademarks are the property of their respective owners.

Edition 2020-03-13

Published by

Infineon Technologies AG

81726 Munich, Germany

© 2020 Infineon Technologies AG.

All Rights Reserved.

Do you have a question about this document?

Email: erratum@infineon.com

Document reference

ER_1912_PL83_1912_082653

IMPORTANT NOTICE

The information contained in this application note is given as a hint for the implementation of the product only and shall in no event be regarded as a description or warranty of a certain functionality, condition or quality of the product. Before implementation of the product, the recipient of this application note must verify any function and other technical information given herein in the real application. Infineon Technologies hereby disclaims any and all warranties and liabilities of any kind (including without limitation warranties of non-infringement of intellectual property rights of any third party) with respect to any and all information given in this application note.

The data contained in this document is exclusively intended for technically trained staff. It is the responsibility of customer's technical departments to evaluate the suitability of the product for the intended application and the completeness of the product information given in this document with respect to such application.

For further information on the product, technology, delivery terms and conditions and prices please contact your nearest Infineon Technologies office (www.infineon.com).

WARNINGS

Due to technical requirements products may contain dangerous substances. For information on the types in question please contact your nearest Infineon Technologies office.

Except as otherwise explicitly approved by Infineon Technologies in a written document signed by authorized representatives of Infineon Technologies, Infineon Technologies' products may not be used in any applications where a failure of the product or any consequences of the use thereof can reasonably be expected to result in personal injury.