

# BGT60TR13C

## Datasheet V2.4.9

### Features

- 60 GHz radar sensor for FMCW operation
- 5.5 GHz bandwidth
- Antenna-in-package (6.5 x 5.0 x 0.9 mm<sup>3</sup>)
- Digital interface for chip configuration and radar data acquisition
- Optimized power modes for low-power operation
- Integrated state machine for independent operation

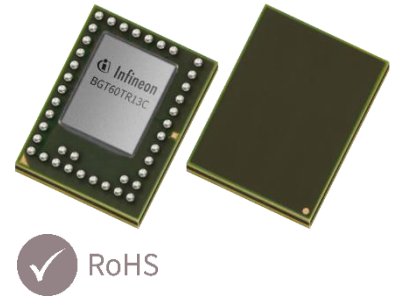

### Potential applications

- Radar frontend for gesture sensing
- High resolution FMCW radars
- Short range sensing operations
- Hidden sensing applications behind radome

### Product validation

Packaged device qualified according to JEDEC 20/22.

### Description

The BGT60TR13C, a 60 GHz radar sensor with antenna in package, enables ultra-wide bandwidth FMCW operation in a small package. Sensor configuration and data acquisition are enabled with a digital interface and the integrated state machine enables independent data acquisition with power mode optimization for lowest power consumption.

## Table of contents

<b>Table of contents</b> .....	<b>2</b>
<b>1 Introduction</b> .....	<b>5</b>
1.1 Product Overview .....	5
1.2 Potential Applications.....	5
1.3 BGT60TR13C Bare Die Block Diagram .....	6
1.4 BGT60TR13C Pin Definition and Function .....	7
1.4.1 IO and Supply Pins .....	8
1.5 BGT60TR13C Functional Block Diagram .....	9
<b>2 General Product Specification</b> .....	<b>11</b>
2.1 Absolute Maximum Ratings .....	11
2.2 Range of Functionality .....	11
2.3 Current Consumption .....	12
2.4 ESD Integrity .....	14
2.5 Thermal Resistance .....	15
2.6 Product Validation .....	15
<b>3 Shapes, Frames, and Channel Set Definition</b> .....	<b>16</b>
3.1 Shapes and Frames .....	16
3.2 Channel Set.....	18
3.3 Power Modes .....	19
3.3.1 Mode Descriptions.....	19
3.3.2 Power Modes and Timings.....	20
3.3.3 Wake-Up Phase from “Deep Sleep” to “Idle” .....	21
3.3.4 Idle to Interchirp then Active .....	22
3.3.5 Saw-tooth Shape Timing .....	24
3.3.6 Different Power Modes after Shapes and Shape Groups.....	24
3.3.6.1 Idle after Shape or Shape Groups.....	24
3.3.6.2 Interchirp in-between Shapes .....	26
3.3.6.3 Deep Sleep Continuous + Idle wake-up after shape groups .....	27
3.4 System Constraints .....	28
3.4.1 MADC Sampling Timing Conditions and Calculations .....	28
3.4.2 PLL Frequency Ramp Setup.....	30
<b>4 BGT60TR13C Registers</b> .....	<b>33</b>
4.1 Register List .....	33
4.1.1 Abbreviations .....	35
4.2 MAIN – Main Register .....	35
4.3 ADC0 – MADC Control Register.....	37
4.4 CHIP_ID.....	38
4.5 STAT1 - Status Register1 .....	39
4.6 PACR1: PLL Analog Control Registers 1 .....	40
4.7 PACR2: PLL Analog Control Registers 2 .....	42
4.8 SFCTL – SPI and FIFO Control Register.....	43
4.9 SADC_CTRL Sensor ADC Control Register .....	44
4.10 CSx: Channel Set Registers.....	46
4.11 CSCx - Channel Set Control Register .....	50
4.12 CCR0 - Chirp Control Registers 0.....	51
4.13 CCR1 - Chirp Control Registers 1.....	52
4.14 CCR2 - Chirp Control Registers 2.....	53

4.15	CCR3 - Chirp Control Registers 3.....	54
4.16	PLLx[0..6] - Chirp Shape Registers .....	55
4.17	PLLx[7] – SCR Shape Control Register .....	56
4.18	PLL DFT0 Register.....	57
4.19	RFT0 – RF Test Register 0 .....	58
4.20	RFT1 – RSVD .....	59
4.21	STAT0 - Status Register 0 .....	59
4.22	SADC_RESULT Sensor ADC Result Register.....	60
4.23	FSTAT - FIFO Status Register.....	61
4.24	GSR0 - Global Status Register .....	63
<b>5</b>	<b>Data Organization and SPI Interface .....</b>	<b>64</b>
5.1	Data Header.....	64
5.2	FIFO and Dataflow .....	65
5.3	SPI – Serial Peripheral Interface Module .....	66
5.3.1	Standard SPI Timing .....	67
5.3.2	Logic Levels .....	69
5.4	Overshoot and Undershoot Waveform Definition .....	73
5.5	IBIS Model.....	74
5.6	SPI Functionality .....	74
5.7	SPI Burst Mode .....	75
5.8	SPI Error Detection .....	78
5.9	Hardware Reset Sequence.....	79
5.10	Software Triggered Resets .....	79
<b>6</b>	<b>PLL Domain Functional Specification .....</b>	<b>81</b>
6.1	PLL Interfaces and Clock Distribution: .....	81
6.2	Reference Clock Distribution .....	81
6.2.1	Interfaces to the PLL .....	82
6.3	PLL Parameters and Specification.....	82
6.3.1	Frequency Ramp Linearity Definition:.....	83
6.3.2	Frequency Ramp Settling Time .....	83
<b>7</b>	<b>Analog-RF Domain Functional Specification .....</b>	<b>84</b>
7.1	RF Frontend (RF FE).....	84
7.1.1	On-Chip Analog Sensor Output .....	84
7.1.2	RF FE Specifications .....	85
7.2	Analog Baseband: Amplifiers and Filters.....	86
7.2.1	Baseband Characteristics .....	87
7.2.2	Baseband Requirements.....	87
<b>8</b>	<b>MADC Domain Functional Specification .....</b>	<b>89</b>
8.1	MADC Supply Voltage Requirements.....	89
8.2	MADC Specifications.....	90
8.3	MADC Timing Diagrams.....	92
8.4	MADC Startup Sequence .....	92
8.5	MADC Conversion Rate.....	93
8.5.1	Sampling.....	93
8.5.2	Conversion.....	93
8.5.3	Tracking.....	94
8.5.4	ADC Conversion Rate .....	94
8.5.5	ADC Sampling Rate .....	94
<b>9</b>	<b>SADC Domain Functional Specification .....</b>	<b>95</b>

9.1	SADC Functionality.....	95
9.2	SADC Conversion Formula.....	96
<b>10</b>	<b>Enhanced Functions .....</b>	<b>97</b>
10.1	Data Test Mode.....	97
10.2	CW Mode.....	97
10.2.1	Enabling the CW mode.....	98
10.2.2	Baseband and ADC Test Mode.....	99
10.3	IRQ Output.....	101
<b>11</b>	<b>Example of Typical Configurations.....</b>	<b>102</b>
11.1	Case #1.....	102
<b>12</b>	<b>Package .....</b>	<b>108</b>
12.1	Built-in Antenna Specifications .....	110
<b>13</b>	<b>Abbreviations .....</b>	<b>111</b>
<b>14</b>	<b>Revision History.....</b>	<b>112</b>

## Introduction

### 1 Introduction

New smart sensors for gesture recognition can be based on radar systems, in special case, FMCW radars. Those systems can comprise several blocks: Radio Frequency (RF) front-end, Analog Base Band (ABB), Analog to Digital Converter (ADC), Phase Locked Loop (PLL), memory (FIFO e.g.), Serial Peripheral Interface (SPI) and Antennas. Smart sensors require a high level of integration, thus, the components listed above should be integrated in a single chip solution. BGT60TR13C offers this level of integration in a single chipset.

#### 1.1 Product Overview

The core functionality of BGT60TR13C is to transmit frequency modulated continuous wave (FMCW) signal via the transmitter channel (TX) and receive the echo signals from the target object on the three receiving channels (RX). Each receiver path includes a baseband filtering, a VGA, as well as an ADC. The digitized output is stored in a FIFO. The data are transferred to an external host, microcontroller unit (MCU) or application processor (AP), to run radar signal processing. A typical implementation of a sensor system consists of two main blocks only (see Figure 1):

- BGT60TR13C handles the RF signals and provides the sampled IF signals
- Application Processor which captures and processes the radar signals

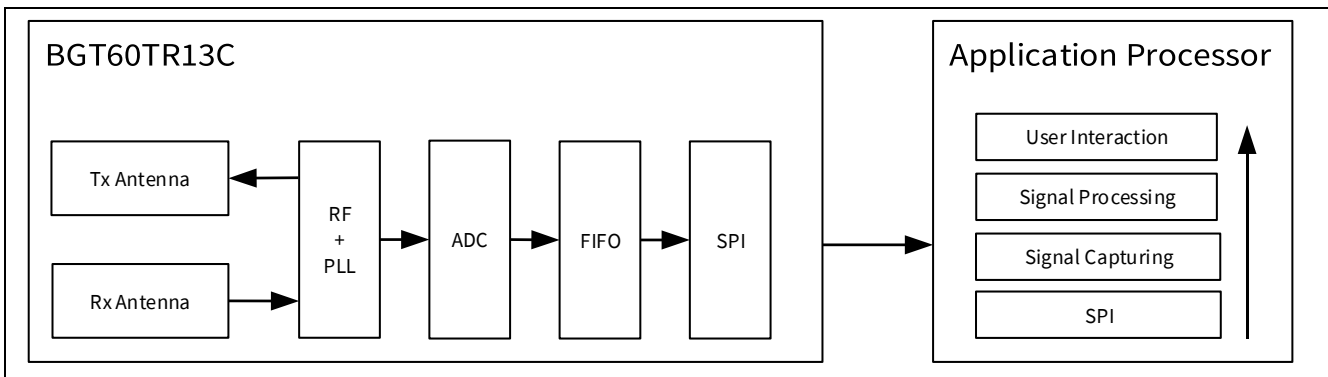

**Figure 1** Data flow in the complete radar sensor system

#### 1.2 Potential Applications

The chipset has been designed to address mainly the following potential applications:

- Radar frontend for gesture sensing
- High resolution FMCW radars
- Short range sensing operations
- Hidden sensing applications behind radome

## Introduction

### 1.3 BGT60TR13C Bare Die Block Diagram

BGT60TR13C block diagram is presented in Figure 2.

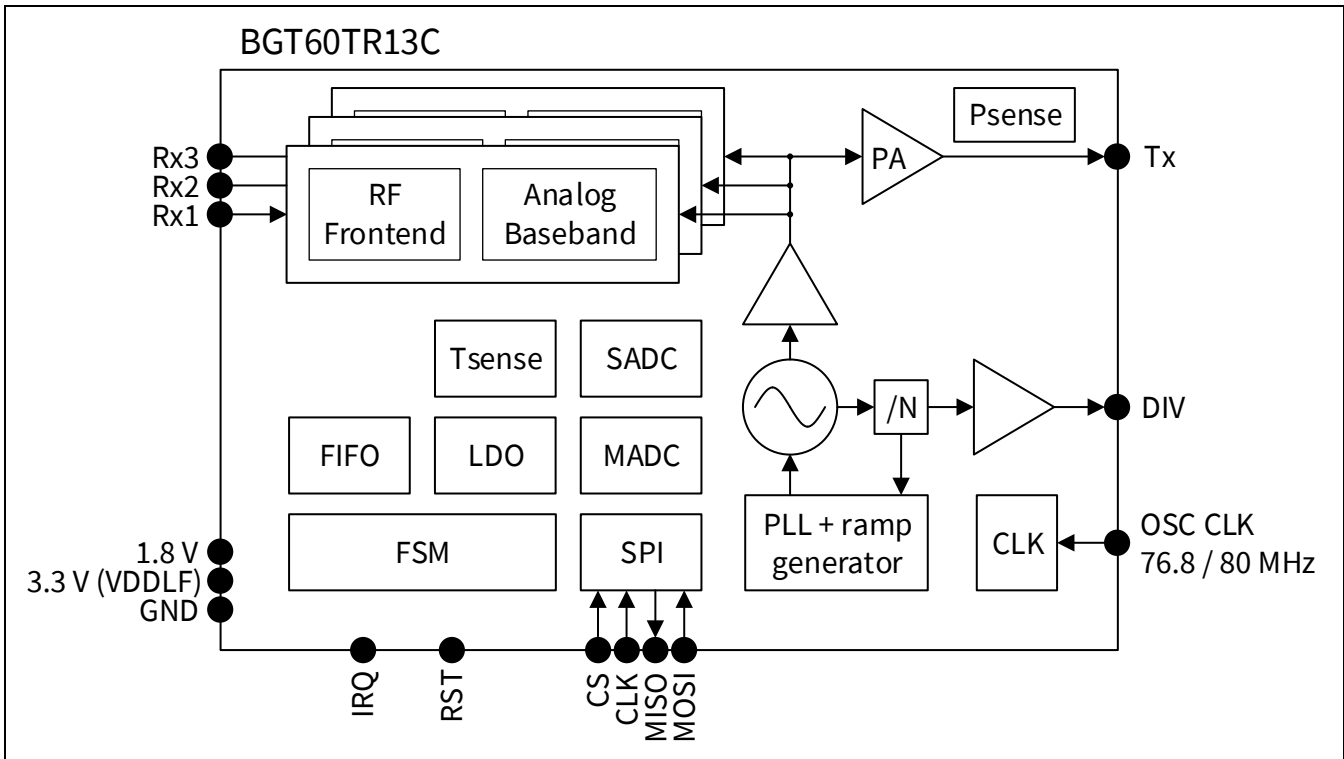

Figure 2 BGT60TR13C Bare die block diagram

#### Feature List:

- Single supply voltage level of 1.8 V for both, digital and analog domains
- Integrated LDOs from 1.8 V to 1.5 V to supply the digital domain
- RF-Frontend at 60 GHz covering frequencies from 58.0 to 63.5 GHz with one TX and three RX channels
- Baseband chain consisting of high pass filter, low noise voltage gain amplifier (VGA), and antialiasing filters
- Three ADC channels with 12 bits resolution and up to 4 MSps sampling rate to sample the RX-IF channels
- Integrated RF-PLL, timers, counters, and FSM to run set of frames in standalone mode (no communication with AP required except first trigger and raw data transfer)
- Full duplex FIFO structure as data buffer (196 kbit = 8192 words x 24 bits)
- Linear Feedback Shift Register (LFSR) test pattern generator on chip for data transfer check
- 8 to 10 bits sensor ADC for power and temperature measurement
- Standard SPI mode for configuration and status register read accesses
- Dedicated power modes for power reduction
- An external 80 MHz reference oscillator is used as a system clock source
- BITE (Built in test equipment) for EOL test in production at Infineon to verify RF performance
- Fabricated with BiCMOS Infineon process technology
- Housed in a laminate package
- Antennas integrated in the redistribution layers of the package

# BGT60TR13C

## Datasheet

### Introduction

#### 1.4 BGT60TR13C Pin Definition and Function

The following Figure 3 shows the bottom view of the BGT60TR13C laminate package with the pin and antenna number assignment.

The function of each pin is described in Table 1 (See also Table 2 and Table 3).

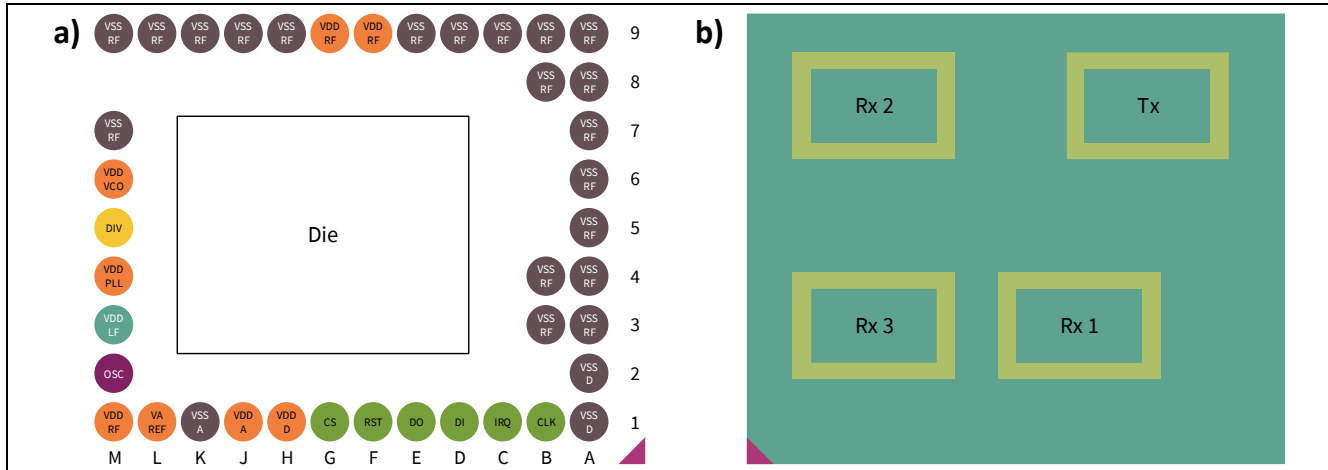

**Figure 3 BGT60TR13C pin out in bottom view (a) and antenna numbers assignment in top view (b)**

**Table 1 Ball and Antenna Definition**

Ball	Function
A1, A2	VSSD
B1	CLK
C1	IRQ
D1	DI
E1	DO
F1	DIO3
G1	CS_N
H1	VDDD
J1	VDDA
K1	VSSA
L1	VAREF
M1, F9, G9	VDDRF
M2	OSC_CLK
M3	VDDLf
M4	VDDPLL
M5	DIV_TEST
M6	VDDVCO
M7, M9, L9, K9, J9, H9, E9, D9, C9, B9, B8, A9, A8, A7, A6, A5, B4, A4, B3, A3	VSSRF
Antenna	Function
Tx1	Transmitter
Rx1	Receiver ch1

## Introduction

**Table 1 Ball and Antenna Definition**

Ball	Function
Rx2	Receiver ch2
Rx3	Receiver ch3

### 1.4.1 IO and Supply Pins

The following Table 2 gives an overview on the input/output pins of BGT60TR13C.

**Table 2 BGT60TR13C Input/Output Pins**

Symbol	Type	Domain	Description	Domain
DIV_TEST	A <sub>OUT</sub>	VDDRF	VCO divided by 16 output	Analog-RF
OSC_CLK	A <sub>IN</sub>	VDDRF	80 MHz (e.g.) Xtal input	Analog-RF
CLK	D <sub>IN</sub>	VDDD	SPI CLK input	SPI
IRQ	D <sub>OUT</sub>	VDDD	Interrupt output	Control FSM
CS_N	D <sub>IN</sub>	VDDD	SPI chip select input, active low	SPI
DI	D <sub>IN</sub>	VDDD	SPI signal from the host output	SPI
DO	D <sub>OUT</sub>	VDDD	SPI signal to the host input	SPI
DIO3	D <sub>IN</sub> / D <sub>OUT</sub>	VDDD	HW reset pin	SPI

The power supply pins are described in Table 3.

**Table 3 BGT60TR13C Supply Pins**

Symbol	Type	Domain	Description	Domain
VDDD	V <sub>IN</sub>	1.8 V	Digital supply voltage	Digital
VDDA	V <sub>IN</sub>	1.8 V	Analog supply voltage	ADC
VAREF	V <sub>OUT</sub>	1.2 V	Positive reference voltage output; for bypass cap	ADC
VDDVCO	V <sub>IN</sub>	1.8 V	Analog supply voltage to the VCO	Analog-RF
VDDRF	V <sub>IN</sub>	1.8 V	Analog supply voltage	Analog-RF
VDDLf	V <sub>IN</sub>	3.3V	Analog supply voltage for the level shifter for the PLL loop filter	Analog-RF
VDDPLL	V <sub>IN</sub>	1.8 V	Analog supply voltage to the PLL	Analog-RF
VSSRF	GNDA	0 V	Analog ground connection	Analog-RF
VSSA	GNDA	0 V	Analog ground connection	ADC
VSSD	GNDD	0 V	Digital ground connection	Digital

#### Abbreviations:

V<sub>IN</sub> ... supply voltage input pin

D<sub>IN</sub> ... digital input pin

D<sub>OUT</sub> ... digital output pin

V<sub>OUT</sub> ... supply voltage output pin



## Introduction

A<sub>OUT</sub> ... analog output pin

A<sub>IN</sub> ... analog input pin

G<sub>NDA</sub> ... analog ground connection

G<sub>NDD</sub> ... digital ground connection

## 1.5 BGT60TR13C Functional Block Diagram

BGT60TR13C consists of some main functional blocks:

- **Antenna** built in package, see Figure 81
- **RF Frontend** consisting of 3ch Rx, 1ch Tx, LO generation, and divider by 4/5, see paragraph 7.1
- **ABB**, analog baseband consisting of high pass filter (HPF), VGA, anti-aliasing filter (AAF), see paragraph 7.2
- **PLL**, 3<sup>rd</sup> order sigma-delta based to perform FMCW ramp
- **MADC**, 3ch 12 bits differential SAR ADCs interfaced to the ABB via a driver and to the FIFO via a mux, see paragraph 8
- **SADC**, 8 to 10 bits single-ended SAR ADC used to sense the sensor data, see section 9
- **FIFO**, 196 kbit= 8192 words x 24 bits
- **Register banks**, 127 registers, see paragraph 4
- **SPI**, up to 50 MHz clock in standard mode
- **FSM**, finite state machine which manages the complete chip
- Clockwise, two domains can be identified:
  - 80 MHz system clock (SYS\_CLK) domain for PLL, MADC, SADC, and FIFO
  - 50 MHz (e.g.) SPI clock

The main FSM syncs those two domains.

## Introduction

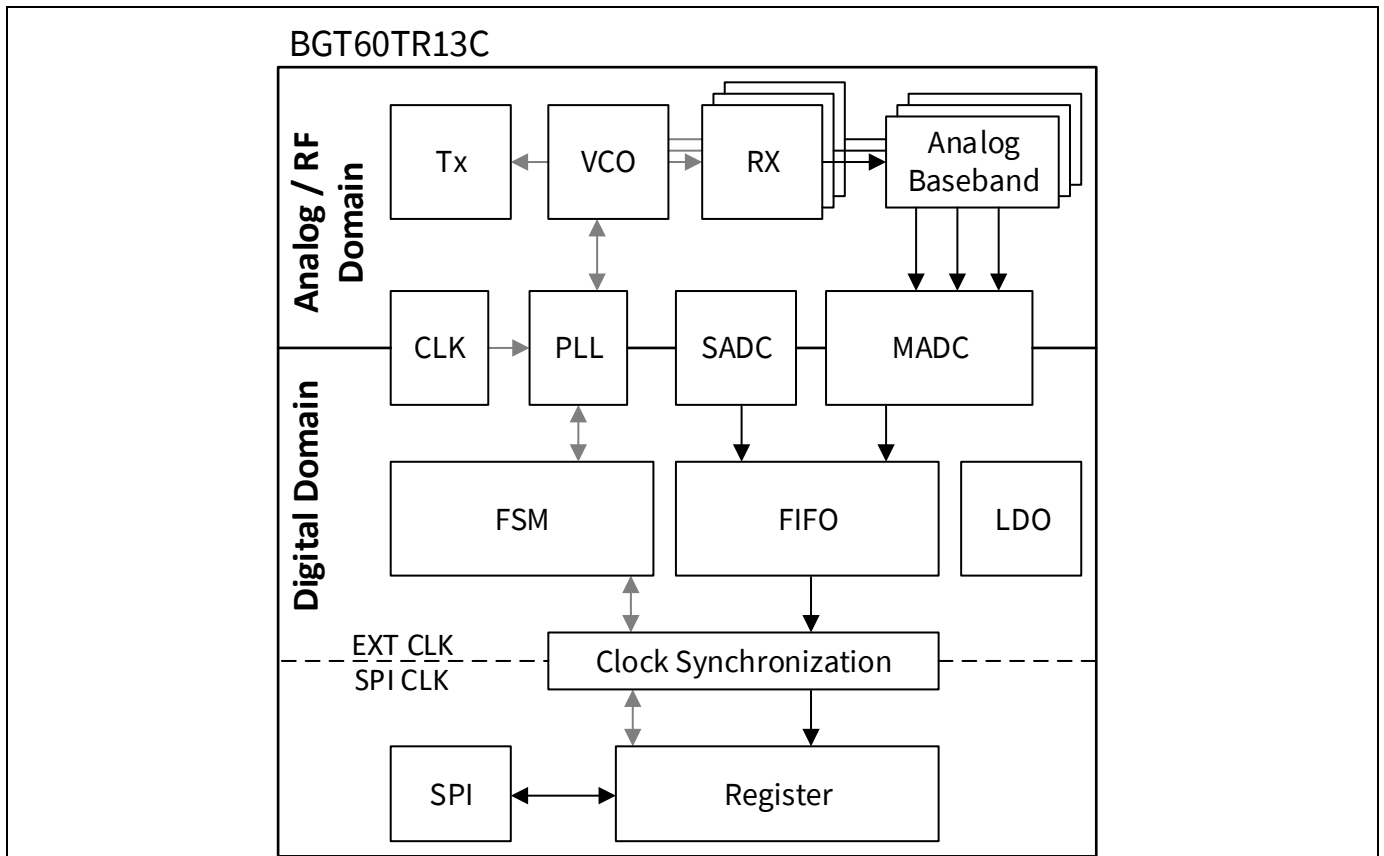

Figure 4 BGT60TR13C functional overview

## General Product Specification

### 2 General Product Specification

The reference for all specified data is the Infineon application board, available on request.

#### 2.1 Absolute Maximum Ratings

**Table 4 Absolute Maximum Ratings**  $T_b = -40\text{ °C}$  to  $105\text{ °C}$ , all voltages with respect to ground, positive current flowing into pin (unless otherwise specified). Parameters not subject to production test

Spec	Symbol	Unit	Value			Condition
			Min	Typ	Max	
Parameter			Min	Typ	Max	
Supply Voltage	VDDD	V	-0.3		+2	
Supply Voltage	VDDA	V	-0.3		+2	
Supply Voltage	VDDRF	V	-0.3		+2	
Supply Voltage	VDDVCO	V	-0.3		+2	
Supply Voltage	VDDPLL	V	-0.3		+2	
Supply Voltage	VDDLf	V	-0.3		+3.7	
DC Voltage at all I/O Pins	$V_{I/O}$	V	-0.3		VDD+0.3	Not exceeding 2V
RF Input Power Level	PRF	dBm			+10	At the Rx input-port
Junction Temperature	$T_j$	°C	-40		+125	
Storage Temperature	$T_{stg}$	°C	-40		+150	

**Warning:** Stresses above the maximum values listed here may cause permanent damage to the device. Maximum ratings are absolute ratings; exceeding only one of these values may cause irreversible damage to the integrated circuit. Exposure to conditions at or below absolute maximum rating but above the specified maximum operation conditions may affect device reliability and lifetime. Functionality of the device might not be given under these conditions.

#### 2.2 Range of Functionality

**Table 5 Range of Functionality**, VDDD = 1.71 to 1.89 V,  $T_b = -20$  to  $+70\text{ °C}$

Spec	Symbol	Unit	Value			Condition
			Min	Typ	Max	
Parameter			Min	Typ	Max	
Supply Voltage	VDDD	V	1.71	1.8	1.89	Noise on each supply domain should not exceed the level of 20 $\mu$ Vpp in the frequency range 20 kHz – 700 kHz <sup>1)</sup>
Supply Voltage	VDDA	V	1.71	1.8	1.89	
Supply Voltage	VDDRF	V	1.71	1.8	1.89	
Supply Voltage	VDDVCO	V	1.71	1.8	1.89	
Supply Voltage	VDDPLL	V	1.71	1.8	1.89	
Supply Voltage	VDDLf	V	2.5	3.3	3.63	
Chip Backside Temperature	$T_b$	°C	-20		70	Measured with the on-chip temperature sensor
Frequency Range	$f_{RF}$	GHz	58.0		63.5	

## General Product Specification

System Reference Frequency	$f_{\text{SYS\_CLK}}$	MHz	75	80	85	1.8 V CMOS clock; 78 MHz not allowed
Duty cycle of $f_{\text{SYS\_CLK}}$	$f_{\text{DUTSYS}}$	%	45	50	55	
Rise and Fall Time of $f_{\text{SYS\_CLK}}$	$t_{\text{RS,FS,SYS}}$	ns			6	
Phase Jitter of $f_{\text{SYS\_CLK}}$	$J_{\text{PHYSYS}}$	ps		1		BW: 12 kHz to 20 MHz

- <sup>1)</sup> This value will guarantee no artifact/false target in the Range-Doppler map when it is calculated with a minimum of 8 chirps.

## 2.3 Current Consumption

**Table 6 Overall Current Consumption, VDD (all except LF) = 1.71 to 1.89 V and Tb = -20 to +70 °C**

Spec	Symbol	Unit	Value			Condition
			Min	Typ	Max	
Parameter			Min	Typ	Max	
Idd Deep Sleep <sup>1)</sup>	$I_{\text{dd}_{\text{ds}}}$	mA	0.05	0.12	0.555 <sup>5)</sup>	
Idd Idle <sup>2)</sup>	$I_{\text{dd}_{\text{idle}}}$	mA	0.05	2.8	5	
Idd Init0, 3Rx+ 1Tx	$I_{\text{dd}_{\text{int0}}}$	mA	136	175	205	
Idd Init1, 3Rx+ 1Tx <sup>3)</sup>	$I_{\text{dd}_{\text{int1}}}$	mA	141	185	215	
Idd Active, 3Rx + 1Tx <sup>4)</sup>	$I_{\text{dd}_{\text{act}}}$	mA	160	201	230	

- <sup>1)</sup> All registers in reset mode, 80 MHz clock path disabled
- <sup>2)</sup> MADC band gap running
- <sup>3)</sup> Idd for the rest of interchirp similar to Init1
- <sup>4)</sup> Device set in radar mode; DAC Tx set to 31<sub>D</sub>
- <sup>5)</sup> The value at max refers to the max temperature, +70 °C, and the max supply, 1.89 V

**Table 7 VDDD Domain Current Consumption, VDD (any except LF) = 1.71 to 1.89 V and Tb = -20 to +70 °C**

Spec	Symbol	Unit	Value			Condition
			Min	Typ	Max	
Parameter			Min	Typ	Max	
Idd Deep Sleep <sup>1)</sup>	$D I_{\text{dd}_{\text{ds}}}$	mA	0.05	0.1	0.48 <sup>5)</sup>	
Idd Idle <sup>2)</sup>	$D I_{\text{dd}_{\text{idle}}}$	mA	1.5	2.5	3.5	
Idd Init0, 3Rx+ 1Tx	$D I_{\text{dd}_{\text{int0}}}$	mA	2	3	4	
Idd Init1, 3Rx+ 1Tx <sup>3)</sup>	$D I_{\text{dd}_{\text{int1}}}$	mA	3	4	5	
Idd Active, 3Rx + 1Tx <sup>4)</sup>	$D I_{\text{dd}_{\text{act}}}$	mA	3	4	5	

- <sup>1)</sup> All registers in reset mode, 80 MHz clock path disabled
- <sup>2)</sup> MADC band gap running
- <sup>3)</sup> Idd for the rest of interchirp similar to Init1
- <sup>4)</sup> Device set in radar mode and FIFO in low power mode; DAC Tx set to 31<sub>D</sub> for an output power of +5 dBm

## General Product Specification

<sup>5)</sup> The value at max refers to the max temperature +70 °C and the max supply 1.89 V

**Table 8 VDDA Domain Current Consumption, VDD (any except LF) = 1.71 to 1.89 V and Tb = -20 to +70 °C**

Spec	Symbol	Unit	Value			Condition
			Min	Typ	Max	
Parameter			Min	Typ	Max	
Idd Deep Sleep <sup>1)</sup>	Aldd <sub>ds</sub>	mA	0	0.005	0.01	
Idd Idle <sup>2)</sup>	Aldd <sub>idle</sub>	mA	0.01	0.2	0.3	
Idd Init0, 3Rx+ 1Tx	Aldd <sub>int0</sub>	mA	0.5	1.6	3	
Idd Init1, 3Rx+ 1Tx <sup>3)</sup>	Aldd <sub>int1</sub>	mA	0.5	1.6	3	
Idd Active, 3Rx + 1Tx <sup>4)</sup>	Aldd <sub>act</sub>	mA	0.5	1.6	3	

<sup>1)</sup> All registers in reset mode, 80 MHz clock path disabled

<sup>2)</sup> MADC band gap running

<sup>3)</sup> Idd for the rest of interchirp similar to Init1

<sup>4)</sup> Device set in radar mode; DAC Tx set to 31<sub>D</sub>

**Table 9 VDDPLL Domain Current Consumption, VDD (any except LF) = 1.71 to 1.89 V and Tb = -20 to +70 °C**

Spec	Symbol	Unit	Value			Condition
			Min	Typ	Max	
Parameter			Min	Typ	Max	
Idd Deep Sleep <sup>1)</sup>	PLLidd <sub>ds</sub>	mA	0	0.005	0.01	
Idd Idle <sup>2)</sup>	PLLidd <sub>idle</sub>	mA	0	0.005	0.01	
Idd Init0, 3Rx+ 1Tx	PLLidd <sub>int0</sub>	mA	0.6	0.9	1.2	
Idd Init1, 3Rx+ 1Tx <sup>3)</sup>	PLLidd <sub>int1</sub>	mA	5	8	10	
Idd Active, 3Rx + 1Tx <sup>4)</sup>	PLLidd <sub>act</sub>	mA	5	8	10	

<sup>1)</sup> All registers in reset mode, 80 MHz clock path disabled

<sup>2)</sup> MADC band gap running

<sup>3)</sup> Idd for the rest of interchirp similar to Init1

<sup>4)</sup> Device set in radar mode; DAC Tx set to 31<sub>D</sub>

**Table 10 VDDLf Domain Current Consumption, VDD (any except LF) = 1.71 to 1.89 V and Tb = -20 to +70 °C**

Spec	Symbol	Unit	Value			Condition
			Min	Typ	Max	
Parameter			Min	Typ	Max	
Idd Deep Sleep <sup>1)</sup>	LFidd <sub>ds</sub>	mA	0	0.005	0.01	
Idd Idle <sup>2)</sup>	LFidd <sub>idle</sub>	mA	0	0.005	0.01	
Idd Init0, 3Rx+ 1Tx	LFidd <sub>int0</sub>	mA	0.2	0.45	0.5	
Idd Init1, 3Rx+ 1Tx <sup>3)</sup>	LFidd <sub>int1</sub>	mA	0.2	0.45	0.5	
Idd Active, 3Rx + 1Tx <sup>4)</sup>	LFidd <sub>act</sub>	mA	0.2	0.45	0.5	

**General Product Specification**

- 1) All registers in reset mode, 80 MHz clock path disabled
- 2) MADC band gap running
- 3) Idd for the rest of interchirp similar to Init1
- 4) Device set in radar mode; DAC Tx set to 31<sub>D</sub>

**Table 11 VDDRF + VDDVCO Domain Current Consumption, VDD (any except LF) = 1.71 to 1.89 V and Tb = -20 to +70 °C**

Spec	Symbol	Unit	Value			Condition
			Min	Typ	Max	
Parameter			Min	Typ	Max	
Idd Deep Sleep <sup>1)</sup>	RFIdd <sub>ds</sub>	mA	0	0.02	0.045	
Idd Idle <sup>2)</sup>	RFIdd <sub>idle</sub>	mA	0	0.02	0.045	
Idd Init0, 3Rx+ 1Tx	RFIdd <sub>int0</sub>	mA	133	170	196	
Idd Init1, 3Rx+ 1Tx <sup>3)</sup>	RFIdd <sub>int1</sub>	mA	133	170	196	
Idd Active, 3Rx + 1Tx <sup>4)</sup>	RFIdd <sub>act</sub>	mA	151	187	212	

- 1) All registers in reset mode, 80 MHz clock path disabled
- 2) MADC band gap running
- 3) Idd for the rest of interchirp similar to Init1
- 4) Device set in radar mode; DAC Tx set to 31<sub>D</sub>

**2.4 ESD Integrity**

**Table 12 ESD Integrity, VDD(any) = 1.71 to 1.89 V, Tb = -20 to +70 °C**

Spec	Symbol	Unit	Value			Condition
			Min	Typ	Max	
Parameter			Min	Typ	Max	
ESD robustness, HBM All pins	V <sub>ESD-HBM</sub>	V	-2000		+2000	According to JS-001 (R = 1.5 kΩ, C = 100 pF)
ESD robustness, CDM All pins except M2	V <sub>ESD-CDM</sub>	V	-500		+500	According to JS-002
ESD robustness, CDM Pin M2	V <sub>ESD-CDM, M2</sub>	V	-250		+250	According to JS-002

CDM: Field-Induced Charged-Device Model ANSI/ESDA/JEDEC JS-002. Simulates charging/discharging events that occur in production equipment and processes. Potential for CDM ESD events occurs whenever there is metal-to-metal contact in manufacturing.

HBM: Human Body Model ANSI/ESDA/JEDEC JS-001 (R = 1.5 kΩ, C=100 pF).

## General Product Specification

### 2.5 Thermal Resistance

**Table 13 Thermal Resistance, VDD(any) = 1.71 to 1.89 V, Tb = -20 to +70 °C**

Spec	Symbol	Unit	Value			Condition
			Min	Typ	Max	
Parameter						
Package Rth	R <sub>th</sub>	K/W		35		Chip backside to ambient temperature

### 2.6 Product Validation

Qualified for potential applications listed in section 1.2 based on the test conditions in the relevant tests of JEDEC20/22.

**Shapes, Frames, and Channel Set Definition**

**3 Shapes, Frames, and Channel Set Definition**

This section is intended to provide the user with an overview on the overall modulation and power modes capabilities of BGT60TR13C. Specifically, the structure of timers, counters, shapes, channel set and frames will be presented. The section also gives a description of how the main FSM is setting and controlling the PLL for the expected modulation shapes and sequences programmed by the host.

**3.1 Shapes and Frames**

The shape is the modulation chirp that should be performed by the PLL. Two basic shapes are allowed (see Figure 5):

- triangular shape: consisting of a frequency Upchirp and a frequency Downchirp
- saw-tooth shape: consisting of a frequency Upchirp followed by a fast-down chirp

The shapes are set and enabled in the PLLx[0..7] registers (see section 4.16 and 4.17) by the bit PLLx7\_SH\_EN. Up to four different shapes can be programmed. If more than one shape is used, the lower shapes must be programmed (e.g. 3 shapes are needed by the application than x= 1...3).

N\_SHAPE\_EN is the number of shapes enabled.

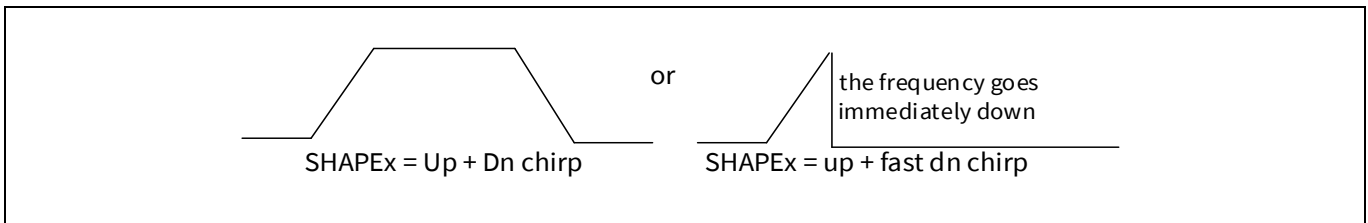

**Figure 5 Shape definition**

**Shape Group**

Each shape defined above can be repeated several times (see Figure 6). The same shape repeated several times represents a shape group. The repetition factor for the shape is called REPSx and described in 4.17. Each shape is repeated up to RSx=2^REPSx times.

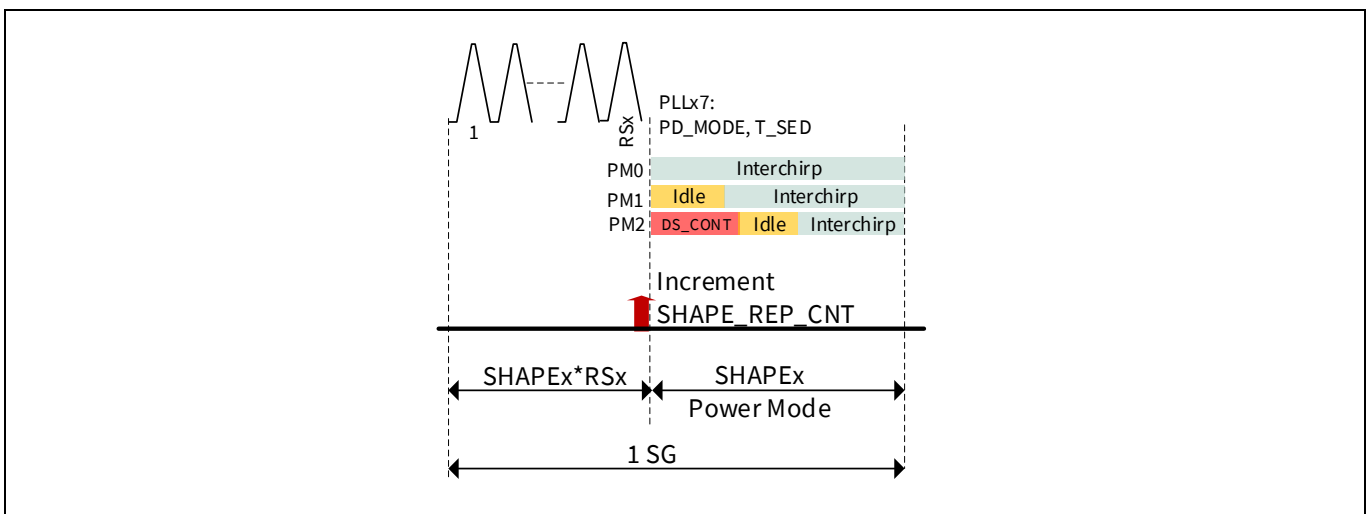

**Figure 6 Shape group**



## Shapes, Frames, and Channel Set Definition

After the last repetitions the FSM will enter, for a period PLLx7:T\_SED (see section 4.17), the power mode programmed according to what specified in PLLx7:PD\_MODE (see section 4.17).

After a shape group, the shape groups counter STAT1: SHAPE\_GRP\_CNT is incremented (see section 4.5). In Figure 7 an example of four programmed shape groups is reported. It represents a shape set.

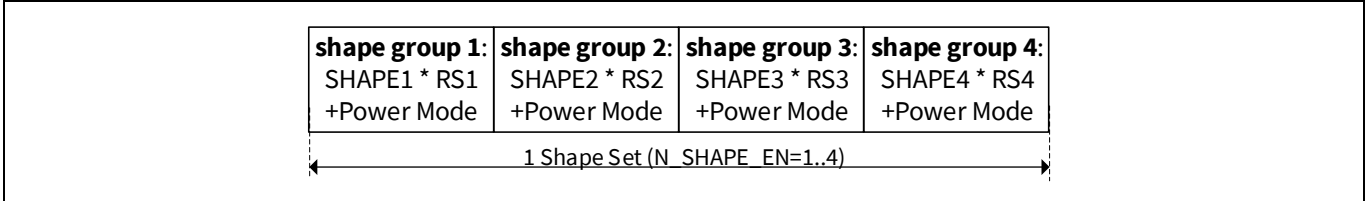

Figure 7 Shape set

### Frame

A frame, as shown in Figure 8, is a sequence of shape sets followed by a specific power mode. Each shape set can be then repeated several times. The repetition factor for the shape set is called REPTx and described in 4.12. Each shape is repeated up to  $RTx = 2^{\wedge}REPTx$  times.

The length of a frame is defined through CCR2: FRAME\_LEN (see section 4.14), which is the number of shape groups to be executed.

At each start of a frame, the first shape SHAPE1 together with the first channel set, CSU1+CSC1 in 0, is loaded.

The number of frame groups the FSM will execute will be:

$$\min(\text{FRAME\_LEN}, \text{N\_SHAPE\_EN} * \text{RT})$$

With  $RT \leq (4096/\text{shape groups})$  and 4095 maximum value allowed for CCR2:FRAME\_LEN.

After the last shape group in a frame, the power mode from CCR1:PD\_MODE is used for the period programmed in CCR1:T\_FED instead of PLLx7:MODE for period PLLx7:T\_SED.

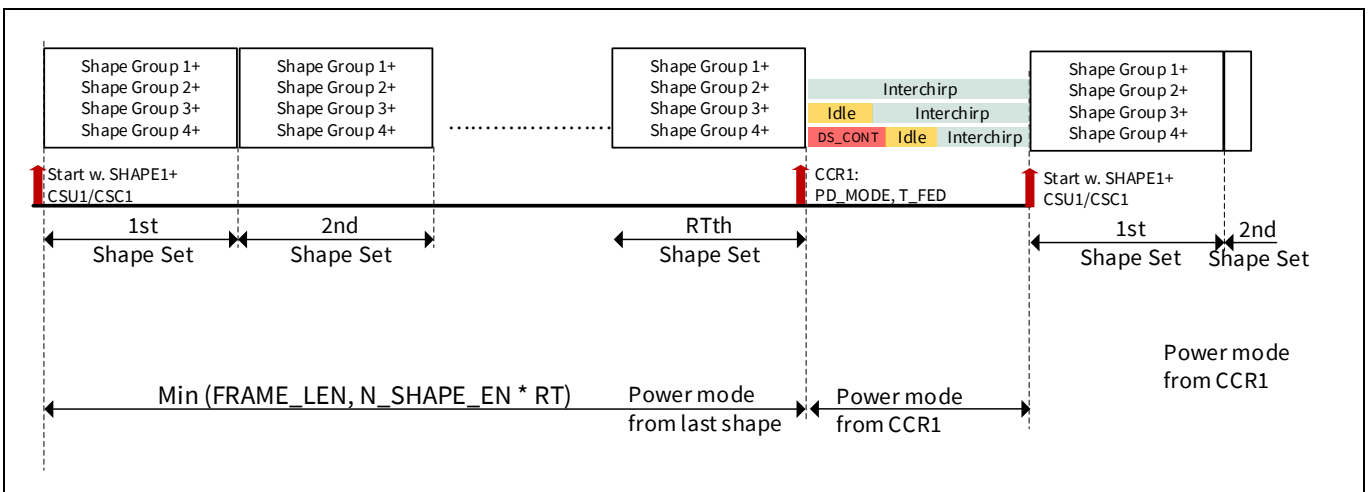

Figure 8 Example of one frame

### Maximum Number of Frames

- The overall frame generation starts after the wake-up period with the first frame
- After the last frame CCR2: MAX\_FRAME\_CNT (see section 4.14) is reached, the FSM will enter the Deep Sleep mode instead of the power mode defined at the end of the last but one frame
  - In order to trigger the chip again, an FSM reset is required.

## Shapes, Frames, and Channel Set Definition

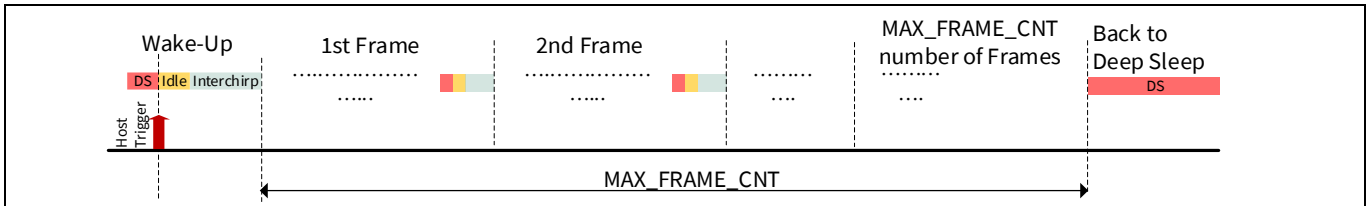

Figure 9 Maximum number of frames

### 3.2 Channel Set

Each channel set can be then repeated several times. The repetition factor for the channel set is called REPCx and described in section 4.11. Each shape is repeated up to  $RCx=2^{REPCx}$  times. There are in total 10 channel sets of 3 different types acting in the specific “modes”. 8 channel sets relate to the shapes (4 shapes x “up” and “down” segment settings) and two to the power modes, Idle and Deep Sleep, respectively:

- Deep Sleep power mode is related to channel set CSDS and CSCDS
- Idle mode is related to channel set CSI and CSCI
- 8 channel sets are defined for the shapes:
  - CSU1 ... CSU4 registers for Upchirp
  - CSD1 ... CSD4 registers for Downchirp
  - CSC1 ... CSC4 channel set registers for up- and Downchirp
- Each shape from above has up to 2 channel sets CSUx and CSDx
  - In case triangular shape is used, CSUx and CSDx are applied
  - In case saw-tooth shape is used, CSD is skipped
- Channel sets are repeating independent of the shapes
- Channel set repetition factor tells how often a single channel set is repeated until the next channel set is loaded
- On the channel set sequence:
  - The lower channel set number is followed by the next higher channel set number
  - In case the highest channel set number is reached, the next channel set loaded is channel set 1
- On the enabling sequence of channel sets:
  - In case not all channel sets are used, the lower number channel sets have to be used
  - In between the enabled channel sets must not be a disabled channel set
  - E.g. 2 channel sets expected: use only CS1 and CS2. In case 3 channel sets are expected, use only CS1, CS2, and CS3
- Start and end of channel set sequences:
  - After reset, the first channel set loaded is CS1.
  - After a frame starts the first channel set loaded will be CS1

Note:

*It would be preferable to have REPS=REPC. This is the actual implementation in the driver.*

## Shapes, Frames, and Channel Set Definition

### 3.3 Power Modes

The following Figure 10 shows the flow chart on all possible power modes for the FSM.

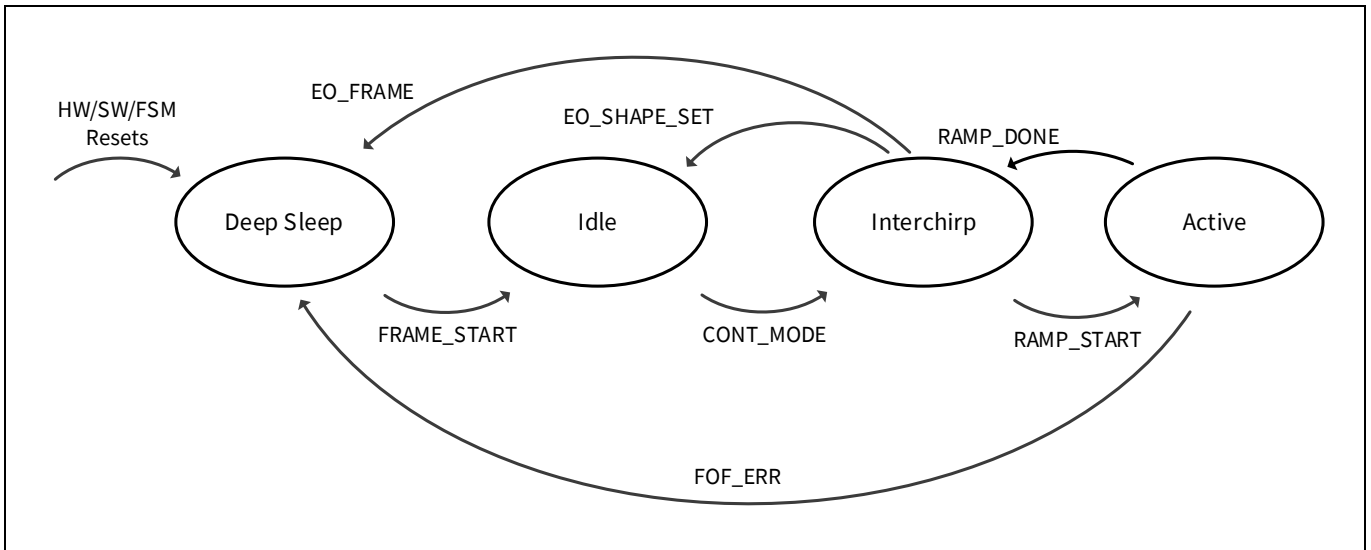

Figure 10 FSM flow chart

#### Power Management through the Power Modes

The power modes enable the host to have full flexibility on power consumption during each state of radar frame generation. A set of isolation registers (CSCx see section 4.11) enables/disables the different blocks on chip. The power modes are managed by the FSM.

#### 3.3.1 Mode Descriptions

In Active, Idle, and Deep Sleep mode the power mode can be defined in the CSCx register, see section 4.11, for all channel sets: CSC1...4, CSI, CSCDS (CSUx= Channel Set Upchirp, CSDx= Channel Set Downchirp, CSI= Channel Set Idle, CSDS= Channel Set Deep Sleep).

##### Active Mode Definition:

- During a shape: PLLx7: PD\_MODE= 0<sub>b</sub>
- Power mode defined through registers CSx (CHS1...CHS4), same mode for Up/Downchirp
- Default Setting: all expected settings are enabled by the host.

##### Interchirp Mode Definition:

- During a shape: PLLx7: PD\_MODE= 0<sub>b</sub>
- Power mode basically the same as Active mode, exception: TX1 off (PAOFF).

##### Idle Mode Definition:

- After a shape: PLLx7: PD\_MODE= 1<sub>b</sub>
- After a frame: CCR1: PD\_MODE= 1<sub>b</sub>
- Idle mode is defined through CSCI

## Shapes, Frames, and Channel Set Definition

- Wake-up from Deep Sleep for MAIN:TR\_WKUP

The Idle mode can be used as a low-power mode in between Interchirp modes or after Deep Sleep mode to further reduce the overall power consumption while not entering the Deep Sleep mode. The wake-up times after Idle mode are faster compared to the ones after Deep Sleep mode.

### Entering Deep Sleep Mode:

- After a shape: PLLx7: PD\_MODE= 2<sub>D</sub> and PLLx7:CONT\_MODE= 0<sub>B</sub>
- After a frame: CCR1: PD\_MODE= 2<sub>D</sub> and CCR0:CONT\_MODE= 0<sub>B</sub>
- Deep sleep mode is defined through CSCDS register (see section 4.11)
- All blocks can be turned off
- Internal 80 MHz clock is also turned off - to achieve extra power saving - when Cont Mode= 0<sub>B</sub> otherwise (Cont Mode= 1<sub>B</sub>) the clock is kept up to count the internal timer T\_FED/T\_SED during the deep sleep.
- In order to wake up the FSM from the Deep Sleep, the host has to program:
  - PACR1:OSCCLKEN= 1<sub>B</sub> to enable the clock gating
  - Then the first trigger can be applied via FRAME\_START.

### Entering Deep Sleep Cont Mode:

- After a shape: PLLx7: PD\_MODE= 2<sub>D</sub> and PLLx7:CONT\_MODE= 1<sub>B</sub>
- After a frame: CCR1:PD\_MODE= 2<sub>D</sub> and CCR0:CONT\_MODE= 1<sub>B</sub>

In case CCR0:CONT\_MODE= 1<sub>B</sub> is enabled, the wake-up from deep sleep is done automatically. The internal system clock is kept running.

### In case of Errors:

If a FIFO overflow condition occurs, the FSM will bring the sensor into the Deep Sleep power mode even if the internal counters are holding the previous value, i.e., the FSM is not reset and a reset is required. In order to reset the FIFO, the host should send at least a MAIN:FIFO\_RESET command (see section 4.2).

If the FIFO overflow occurs, the event is reported in FSTAT:FOF\_ERR (see section 4.23) or in GSR0:FOF\_ERR (see section 4.24).

In this case, the data inside a FIFO can be read from the host as long as no reset occurs.

The flags FSTAT:FOF\_ERR and GSR0:FOF\_ERR are cleared after a reset.

*Note:*

*Each time the SPI will access the chip, the 80 MHz clock will be enabled internally for synchronization reasons.*

## 3.3.2 Power Modes and Timings

This section presents the power modes and states that can be entered by the BGT60TR13C FSM.

## Shapes, Frames, and Channel Set Definition

### 3.3.3 Wake-Up Phase from “Deep Sleep” to “Idle”

After VDDD power up, the main LDO will require 20 μs to settle VDDC. After the reset, the chip will move to a Deep Sleep state. The following figure describes the timing for waking up the chip.

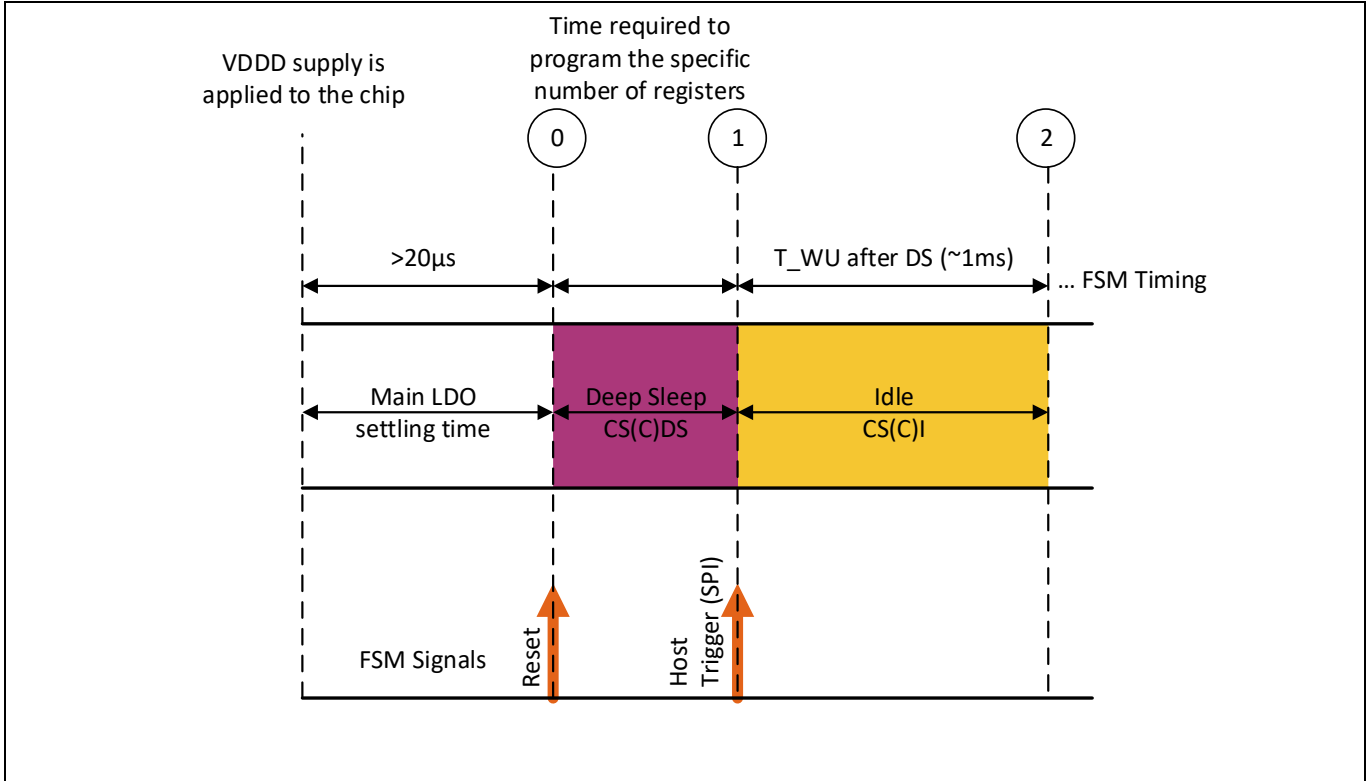

Figure 11 Deep Sleep to Idle transition

Table 14 Transitions from Deep Sleep into Idle

From #	To #	Description	Signals	Related time
#0		Chip is reset by host (see section 5.9).		
#0	#1	Host programs all registers needed for expected functionality.		
#1		Host enables the oscillator: PACR1:OSCCLKEN= 1 <sub>B</sub> to enable the clock gating.		
#1		Host starts the first trigger; it can be applied via FRAME_START.		
#1		Activate bandgap for MADC.		
#1	#2	Time required to settle the ADC BG (charge of external cap).		T_WU
#2		Enable PLL, MADC, and SADC.		
#2		MADC sends ready signal to FSM.	madc_rdy	

Shapes, Frames, and Channel Set Definition

3.3.4 Idle to Interchirp then Active

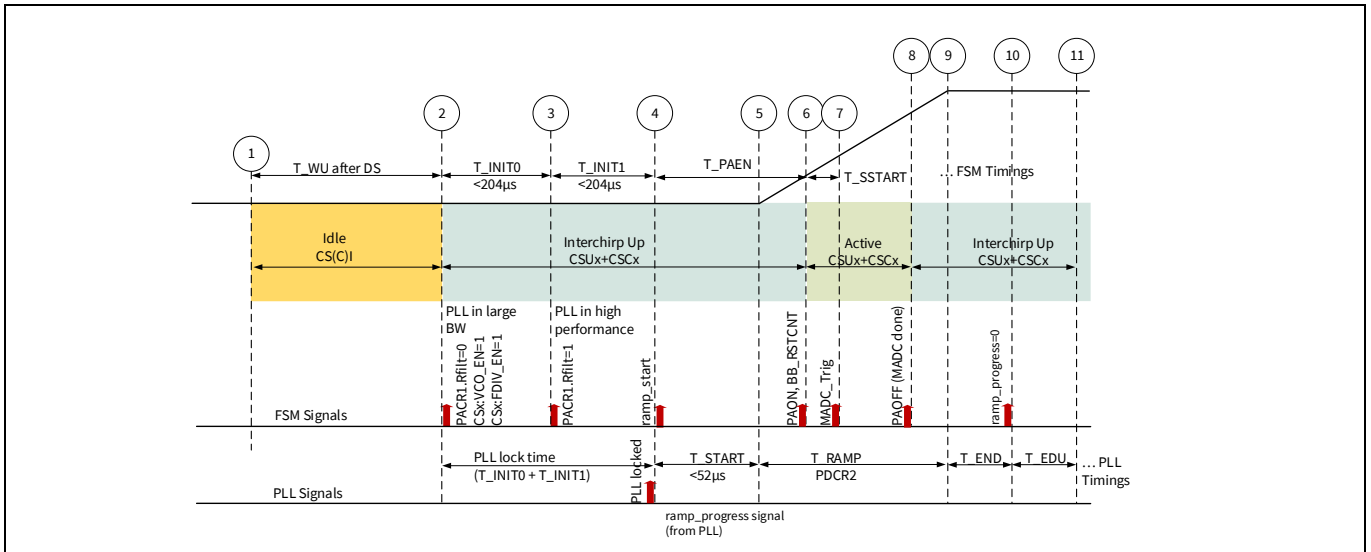

Figure 12 Transition from Idle to Interchirp to Active to Interchirp again

Table 15 Transition from Idle to Interchirp to Active to Interchirp

Fro m #	To #	Description	Signals	Related time
#1		Idle mode is activated.		
#1		Host has to enable the bandgap (CSCI:BG_EN= 1 <sub>B</sub> in section 4.11).		
#1	#2	If Idle mode comes after a Deep Sleep (see transition from Deep Sleep to Idle).		T_WU
#1	#2	If Idle mode comes after an Interchirp mode, the bandgap is already running.		T_SED
#2		Interchirp Up mode is activated by selecting CSUx + CSCx register depending on the actual channel set (see section 4.10).		
#2		Host already enabled the blocks required by the PLL: CSx:VCO_EN= 1 <sub>B</sub> CSx:FDIV_EN= 1 <sub>B</sub>		
#2		FSM sets power mode from CSUx + CSCx.		
#2		FSM sets PACR1.RFILTSEL = 0 <sub>B</sub> .		
#2	#3	The PLL needs some time to initialize the filter settings, 75 µs typ.		T_INIT0
#3	#4	The PLL needs again some time to settle the mode, 15 µs typ.		T_INIT1
#4		PLL sends lock signal to FSM.	PLL_lock	
#4		FSM gives ramp_start signal to PLL.	RAMP_START	
#4	#5	PLL needs some settling time before chirp can start. The PLL timer is running in parallel to the FSM timer. T_START will be evaluated during system testing.		T_START (PLL)
#5	#9	PLL will run the frequency chirp.		T_RAMP

## Shapes, Frames, and Channel Set Definition

From #	To #	Description	Signals	Related time
				(PLL)
#4	#6	Some programmable delay		T_PAEN
#6		<b>Active mode</b> starts here.		
#6		PA is enabled (PAON). Host makes sure that PA is not ON before the chirp starts (>#5).	PAON	
#6		Baseband reset timer is enabled here based on the CSx:BB_RSTCNT value.		
#6	#7	During this phase, the baseband can settle.		T_SSTART
#7		MADC is triggered for the active segment (Up).	MADC_TRIG	
#7		SADC is triggered once here.		
#7	#8	MADC starts acquiring the given number of samples (PLLx:APU in section 4.16). See section 3.4.		T_ACQUx
#8		MADC has completed the acquisition of the expected number of samples.	MADC_DONE	
#8		PA is disabled (PAOFF) This condition must be reached before #9 The condition is: $T\_PAEN + T\_SSTART + T\_ACQUx > T\_START + T\_RAMPx$ .	PAOFF	
#8		<b>Interchirp Up mode</b> is activated again here (CSUx + CSCx).		
#9		PLL has completed the Upchirp.		
#9	#10	Programmable delay time (eg. 3 $\mu$ s).		T_END
#10		Ramp completed.	RAMP_DONE	
#10	#11	Programmable delay time (eg. 1 $\mu$ s).		T_EDU
#11		<b>Interchirp Up</b> mode ends here.		
#11		<b>Interchirp Down</b> mode is programmed here.		

## Shapes, Frames, and Channel Set Definition

### 3.3.5 Saw-tooth Shape Timing

In the saw-tooth mode, after a normal Upchirp segment there will be a fast ramp down segment. The saw-tooth shape should be enabled in the bitfield PACR2:FSTDNEN (see section 4.7). For the saw-tooth only CSU (Upchirp) is used (see section 4.10). The time T\_EDU (see section 4.16, PLLx2#) is applied after the segment is completed.

See Figure 13.

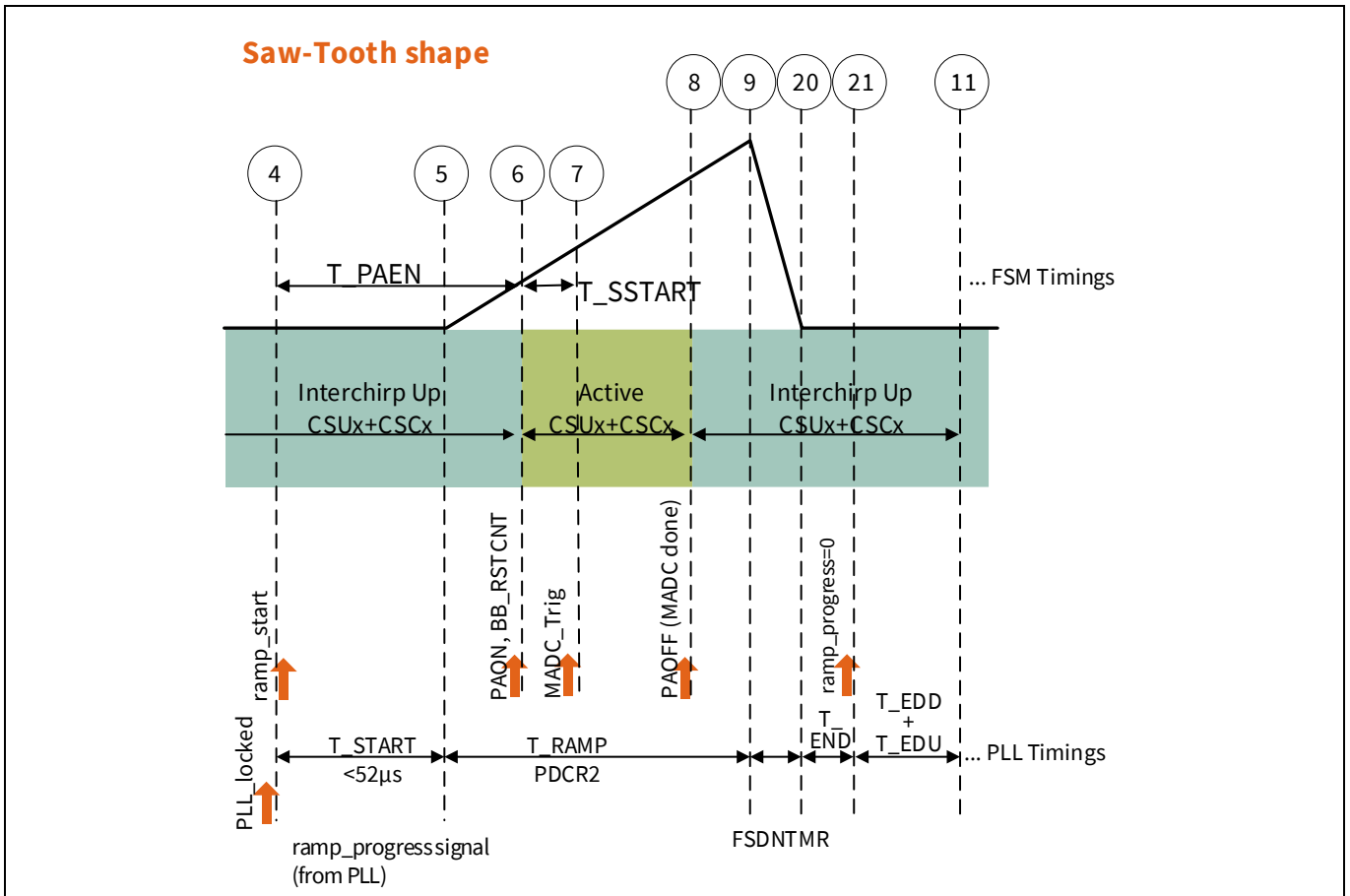

Figure 13 Saw-tooth shape timing

### 3.3.6 Different Power Modes after Shapes and Shape Groups

After the shape ends with Downchirp, the chip can enter different power modes based on the settings (PLLx, CSx, CSCx, ...):

- Interchirp mode in-between shapes – for fast chirp repetitions
- Idle mode after shape groups – in case of longer delay between shape groups and max power saving is required
- Deep Sleep + Idle mode after shape groups in case if very long delays are expected.

#### 3.3.6.1 Idle after Shape or Shape Groups

The Idle mode after a shape or shape groups can be set when a long time in low power mode between shapes is required. Figure 14 represents a time behavior continuation of what presented in Figure 12.



Shapes, Frames, and Channel Set Definition

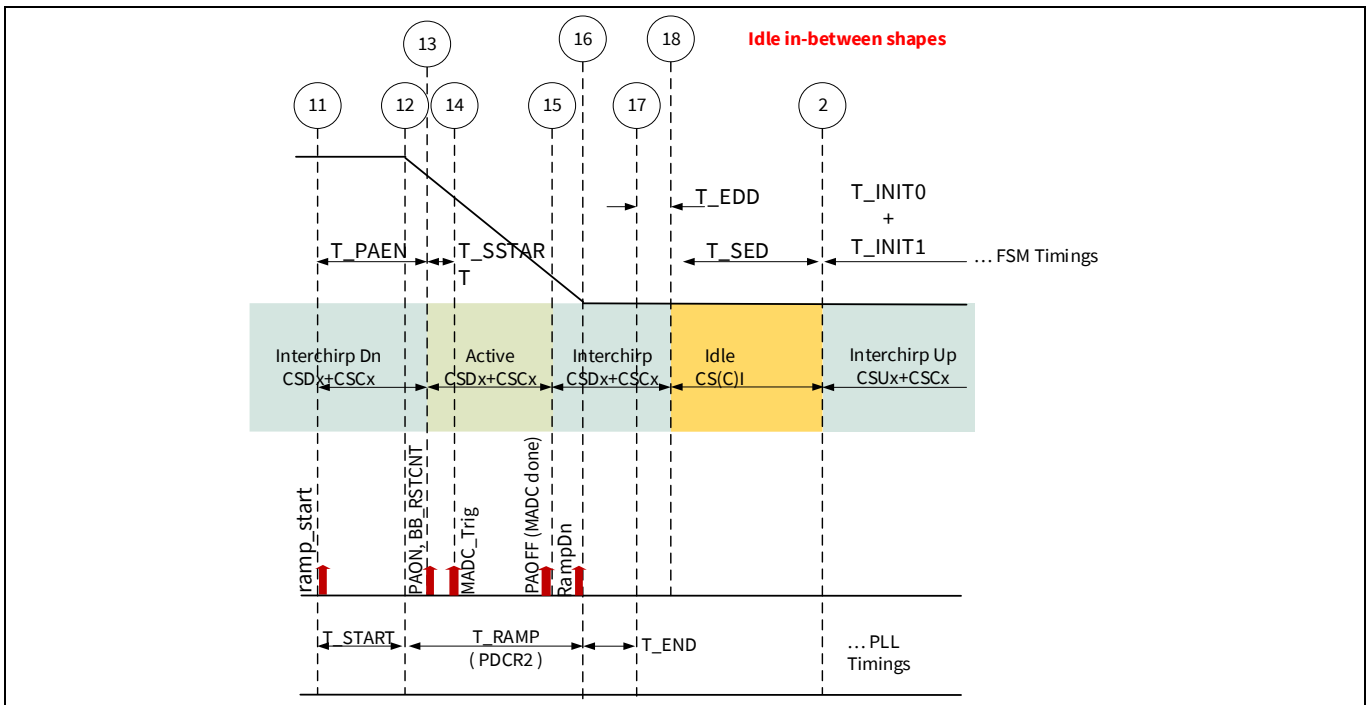

Figure 14 Idle mode after shape groups

Table 16 End of shape and interchirp in-between shapes

From #	To #	Description	Signals	Related time
#11		Interchirp Dn mode is programmed here (CSDx + CSCx).		
#11		FSM generates ramp_start signal.	Ramp_start	
		<b>PLL related:</b>		
#11	#12	Preparation for Downchirp.		T_START
#12	#16	Downchirp time.		T_RAMP
#16	#17	Some delay after Downchirp is completed.		T_END
		<b>FSM related:</b>		
#11	#13	Some delay (see above T_PAEN).		T_PAEN
#13		<b>Active mode</b> is entered with settings from previous Interchirp Dn mode (CSDx+CSCx).		
#13		PA is enabled (PAON). Host ensures that PA is not ON before the chirp starts (>#12).	PAON	
#13		Baseband reset timer is enabled here based on the CSx:BB_RSTCNT value.		
#13	#14	During this phase, the baseband can settle		T_SSTAR
#14	#15	MADC starts acquiring the given number of samples (PLLx:APD in section 4.16). See section 3.4.	MADC_TRIG	T_ACQDx
#15		MADC has completed the acquisition of the expected number of samples.	MADC_DONE	
#15		PA is disabled (PAOFF) This condition must be reached before #16 The condition is:	PAOFF	

### Shapes, Frames, and Channel Set Definition

From #	To #	Description	Signals	Related time
		$T_{PAEN} + T_{SSTART} + T_{ACQDx} > T_{START} + T_{RAMPx}$ .		
#15		<b>Interchirp Dn mode</b> is activated again here ( $CSDx + CSCx$ ).		
#14	#16	FSM waits for PLL if ramp down to calculate #17 (TMREND).		
#16		PLL signals the end of the Downchirp (ramp progress).	RampDN	
#17	#18	Time delay programmed by the host.		$T_{EDD}$
#18	#2	Time programmed by the host to stay in Idle mode.		$T_{SED}$
#2		Same state #2 as in Figure 12 starts here.		

#### 3.3.6.2 Interchirp in-between Shapes

Interchirp between shapes can be set when the required gap between two shapes is relatively small ( $< 25 \mu s$ ).

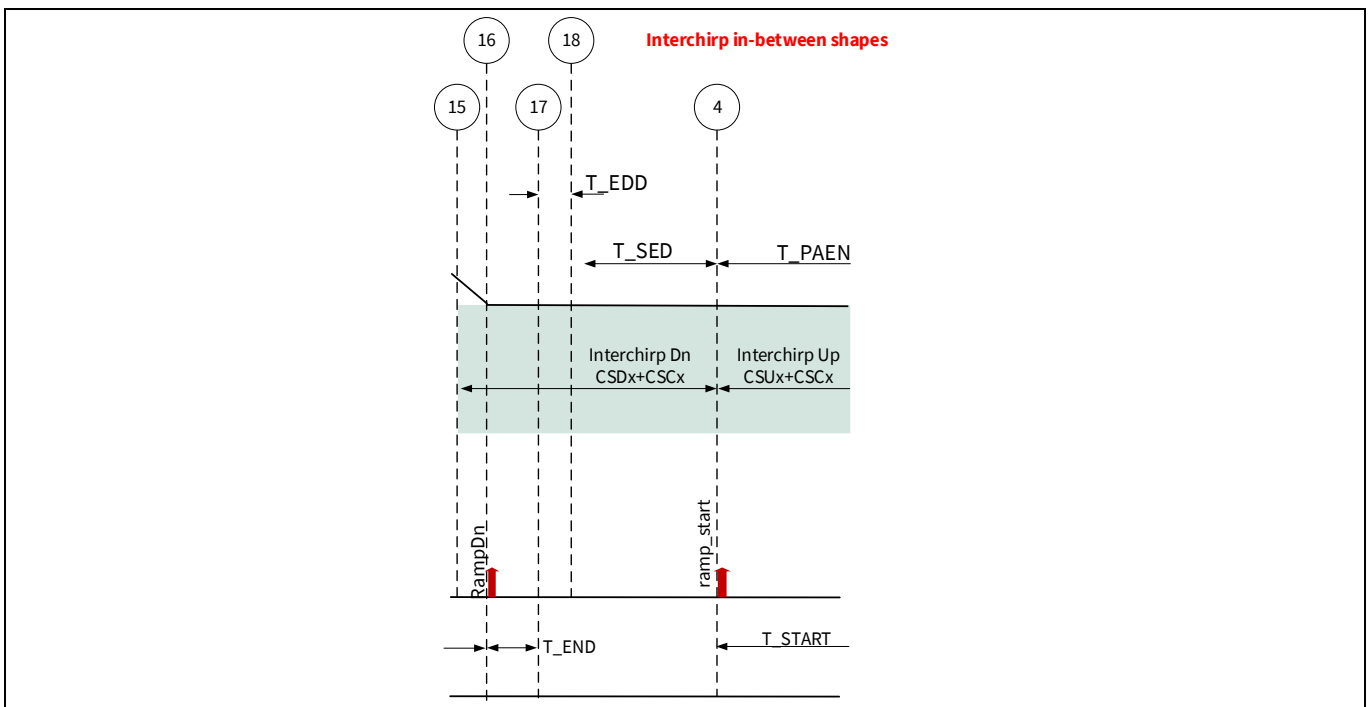

Figure 15 Interchirp in-between shapes

Table 17 Interchirp in-between shapes

From #	To #	Description	Signals	Related time
#15		Interchirp Dn ( $CSDx + CSCx$ ) is activated after Active mode.		
#16		PLL signals the end of the Downchirp (ramp progress).	RampDN	
#16	#17	Some delay after Downchirp is completed.		$T_{END}$
#17		PLL has completed its action.		
#17	#18	Time delay programmed by the host.		$T_{EDD}$
#18	#4	The chip will remain in the same interchirp power state for the provided amount of time ( $T_{EDD}$ ).		$T_{SED}$
#4		Same state #4 as in Figure 12 starts here.		
#4		Interchirp Up mode programmed by FSM here ( $CSUx + CSCx$ ).		

Shapes, Frames, and Channel Set Definition

3.3.6.3 Deep Sleep Continuous + Idle wake-up after shape groups

In Deep Sleep Cont(inuous) mode after the shape group is completed, the FSM wakes up automatically after the programmed time  $T_{SED}$ . The internal clock is kept running during this time. Deep Sleep Cont is the only deep sleep power mode possible between shape groups.

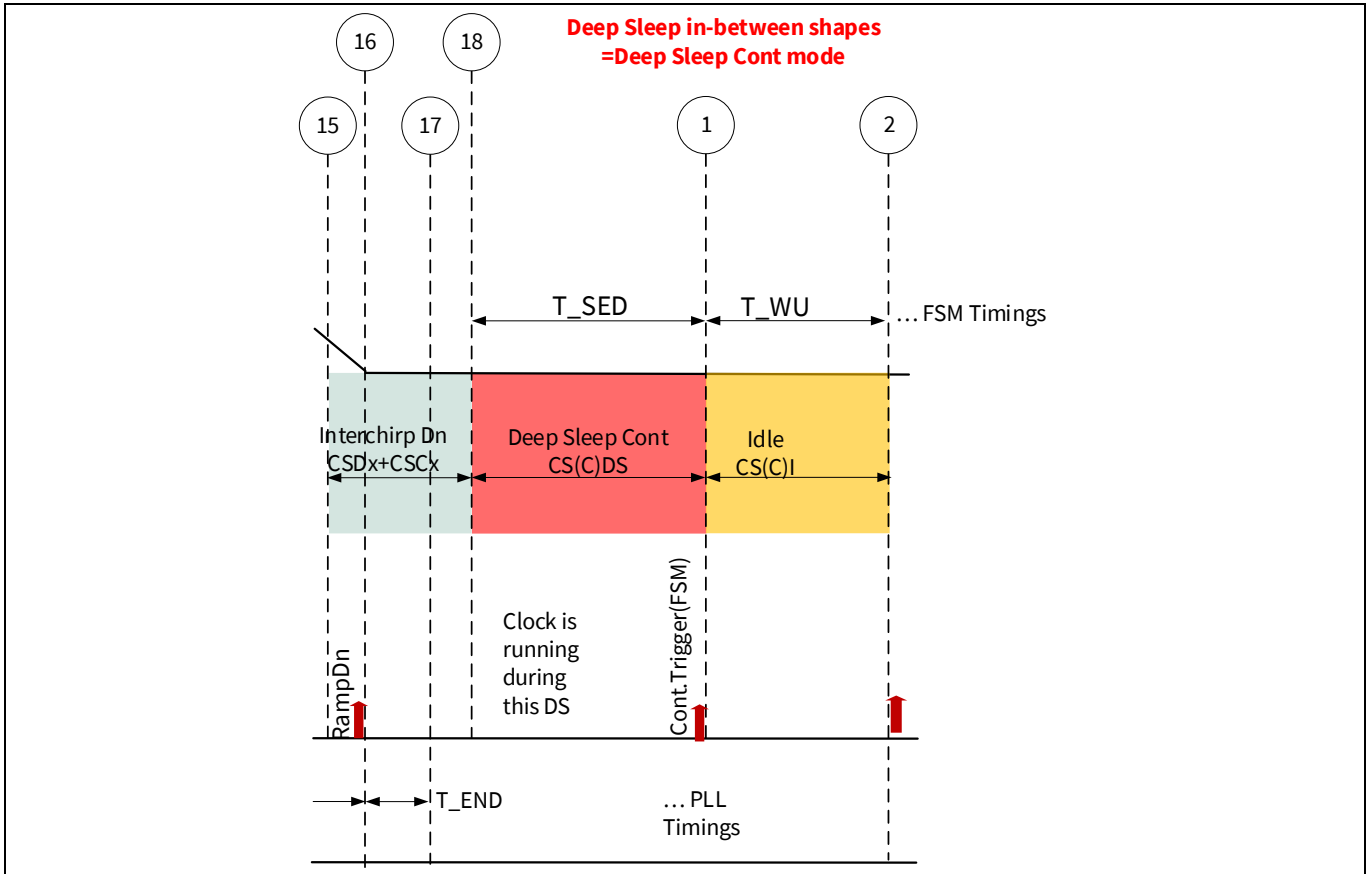

Figure 16 Deep Sleep + Idle wake-up after shape groups

## Shapes, Frames, and Channel Set Definition

Table 18 Deep Sleep Cont + Idle wake-up after shape groups

From #	To #	Description	Signals	Related time
#16	#17	Some delay after Downchirp is completed.		T_END
#17		PLL is completed its action.		
#17	#18	Time delay programmed by the host.		T_EDD
#17		Deep Sleep Cont mode is enabled. The difference to the normal Deep Sleep mode is, the $f_{SYS\_CLK}$ is kept running to count the internal timers.		
#17		The internal system clock $f_{SYS\_CLK}$ is kept running.		
#18	#1	The chip will be in Deep Sleep Cont mode.		T_SED
#1		Continuous trigger coming from the FSM.		
#1		Same start-up procedure as Figure 12 starts here.		

### 3.4 System Constraints

#### 3.4.1 MADC Sampling Timing Conditions and Calculations

The number of MADC samples during a frequency chirp (up or down segment of the shape) should fulfil some specific requirements.

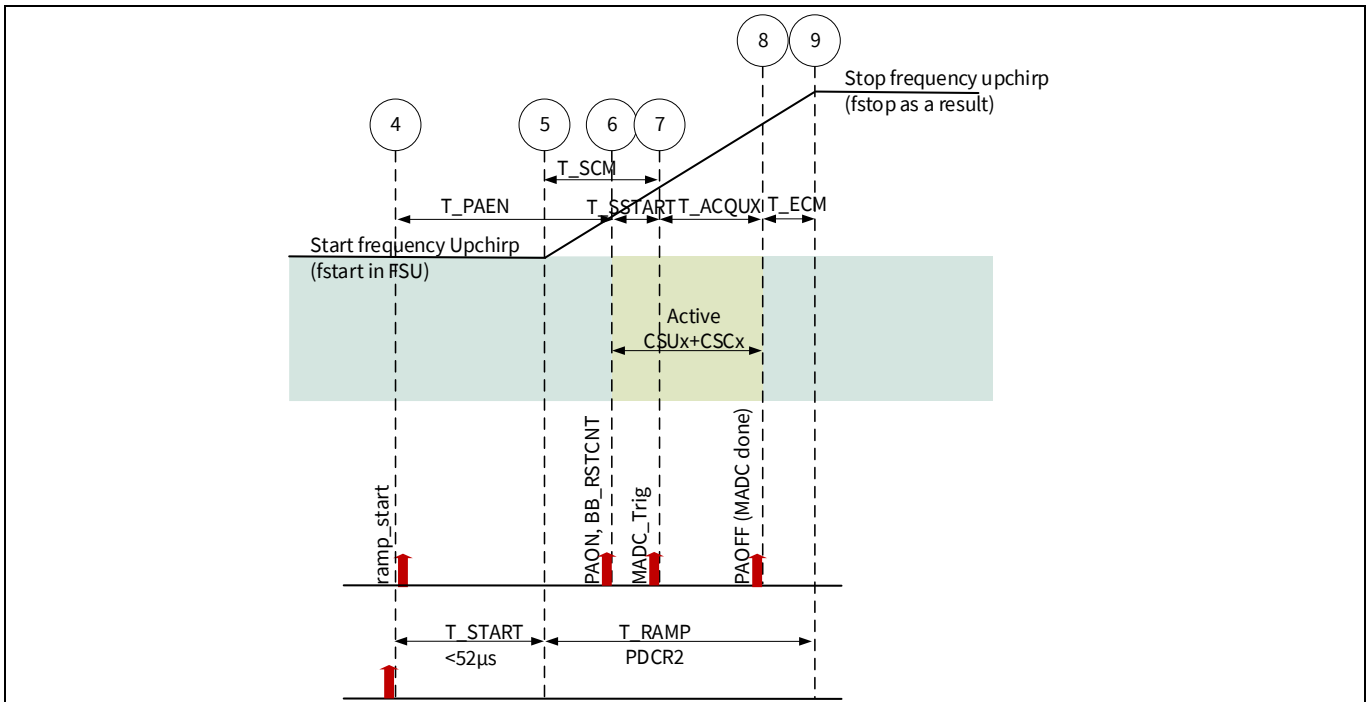

Figure 17 T\_RAMP timing conditions

## Shapes, Frames, and Channel Set Definition

Table 19 T\_RAMP Timing Conditions

From #	To #	Description	Signals	Related time
#4		PLL starts counting.		
#4	#5	PLL starts.		T_START
#5	#9	PLL performs the frequency Upchirp, chirp from fstart (PLLx[1]:FSU) to fstop.		T_RAMP
#6	#8	Active Phase.		
#4	#7	Time to start the MADC.		T_PAEN+T_SSTART
#7	#8	MADC sampling time for Upchirp raw data.		T_ACQUX
#8	#9	End chirp margin T_ECM is needed to avoid transmission out of band. Empirically derived in System.		T_ECM
#5	#7	Start chirp margin T_SCM is needed to avoid transmission out of band. Empirically derived in System.		T_SCM

ADC Sampling Rate  $f_{\text{ADC\_SAMP}}$  (see section 8.5.5):

$$f_{\text{ADC\_SAMP}} = f_{\text{ADC\_CLK}} / \text{ADC\_DIV}$$

ADC acquisition time for Upchirp T\_ACQUx:

$$T_{\text{ACQUX}} = \text{APUx} / f_{\text{ADC\_SAMP}}$$

Where APU is the number of samples.

End chirp margin T\_ECM is tested in system but assumed to be more than 0  $\mu\text{s}$ :

$$T_{\text{ECM}} > 0\mu\text{s}, T_{\text{SCM}} > 0\mu\text{s}$$

Condition on the data acquisition start time:

$$T_{\text{PAEN}} + T_{\text{SSTART}} > T_{\text{START}}$$

Considering the start chirp margin TCM at the beginning:

$$T_{\text{PAEN}} + T_{\text{SSTART}} - T_{\text{SCM}} = T_{\text{START}}$$

Overall timing equation:

$$T_{\text{PAEN}} + T_{\text{SSTART}} + T_{\text{ACQUX}} + T_{\text{ECM}} = T_{\text{START}} + T_{\text{RAMP}}$$

### Example, fixed number of samples:

In case the user expects a fixed number of samples, the APU is set and T\_RAMP is calculated.

The time for a frequency ramp T\_RAMP is:

$$T_{\text{RAMP}} (\text{PLLx2\#:RTU in section 4.16}) = T_{\text{PAEN}} + T_{\text{SSTART}} + T_{\text{ACQUX}} + T_{\text{ECM}} - T_{\text{START}}$$

### Example, Fixed chirp-time (T\_RAMP):

$$T_{\text{ACQUX}} = T_{\text{RAMP}} - (T_{\text{SCM}} + T_{\text{ECM}})$$

$$\text{APU} = (T_{\text{ACQUX}} * f_{\text{ADC\_SAMP}}),$$

$$\text{APU} (\text{PLLx3\#:APU in section 4.16}) = (T_{\text{RAMP}} - (T_{\text{SCM}} + T_{\text{ECM}})) * (f_{\text{SYS\_CLK}} / \text{ADC\_DIV})$$

## Shapes, Frames, and Channel Set Definition

### 3.4.2 PLL Frequency Ramp Setup

The RF frequency ramps generated by the PLL are controlled through the PLLx registers (see section 4.16), where the bit fields FSU, RSU and RTU control the Upchirp of a shape and the registers FSD, RSD and RTD control the down chirp of a shape. The following description refers only to up chirp ramp setup. The given formulas can be adopted to down chirp ramps by replacing FSU by FSD, RSU by RSD and RTU by RTD.

Each RF frequency ramp is defined by the start frequency programmed to FSU, the ramp slope programmed to RSU and the ramp time programmed to RTU. It must be noted that the slope in RSU is specified as frequency increment per clock cycle while the ramp time in RTU is specified as number of steps where a single step means 8 clock cycles. The relation between RSU and RTU is shown in Figure 18.

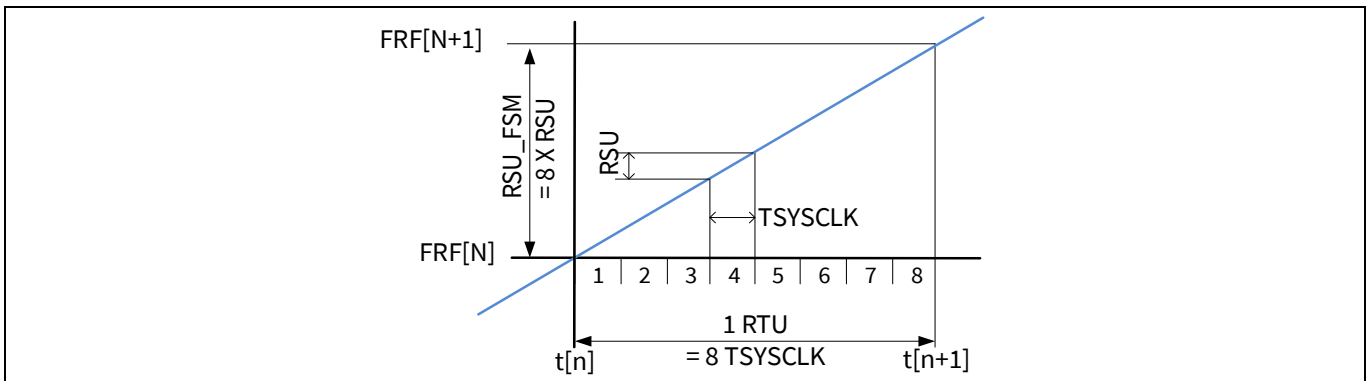

Figure 18 Relationship between RTU and RSU

The value  $N_{FSU}$  that is programmed to FSU bit field to control the ramp start frequency is a signed 2's complement number in the range of  $[-2^{23} \dots (2^{23} - 1)]$ . The relation between the RF frequency  $f_{RF}$  and  $N_{FSU}$  is given by:

$$f_{RF} = 8f_{SYSCLK} \left[ 4(N_{DIVSET} + 2) + 8 + \frac{N_{FSU}}{2^{20}} \right]$$

where  $f_{SYSCLK}$  is the frequency of the reference clock oscillator (typically 80 MHz) and  $N_{DIVSET}$  is the value programmed to the bit field DIVSET in register PACR2 (default 20, see section 4.7). Accordingly, the value  $N_{FSU}$  can be calculated by this formula:

$$N_{FSU} = 2^{20} \left[ \frac{f_{RF}}{8f_{SYSCLK}} - 4(N_{DIVSET} + 2) - 8 \right]$$

The value  $N_{RSU}$  that is programmed to RSU bit field to control the frequency increment per clock cycle is also a signed 2's complement number in the range of  $[-2^{23} \dots (2^{23} - 1)]$ . The relation between the RF frequency increment  $\Delta f_{RF}$  and  $N_{RSU}$  is given by:

$$\Delta f_{RF} = 8f_{SYSCLK} \frac{N_{RSU}}{2^{20}}$$

or

## Shapes, Frames, and Channel Set Definition

$$N_{RSU} = 2^{20} \frac{\Delta f_{RF}}{8f_{SYSCLK}}$$

Note:

Both slope bit fields *RSU* and *RSD* can hold positive and negative values, so an up chirp can also be programmed with a falling ramp and a down chirp can be programmed with a rising ramp. The naming convention “up-chirp” and “down-chirp” are based on the assumption that a triangle shape always starts with the rising ramp. Therefore, regardless of the actual ramp slope the up-chirp registers always refer to the first chirp of a shape and the down chirp registers always refer to the 2<sup>nd</sup> chirp of a shape in triangle mode.

### PLL Setup Example 1 ( $f_{SYSCLK} = 80 \text{ MHz}$ )

With a reference clock frequency of 80 MHz the recommended value for  $N_{DIVSET}$  is 20, the default values. With these parameters the conversion formulas simplify to:

$$N_{FSU} = 2^{20} \left[ \frac{f_{RF}}{640 \text{ MHz}} - 96 \right]$$

and

$$N_{RSU} = 2^{20} \frac{\Delta f_{RF}}{640 \text{ MHz}}$$

With the PLL's 24 bit 2's complement frequency registers the total programmable RF frequency range is  $56.32 \text{ GHz} \leq f_{RF} \leq 66.559 \text{ GHz}$ . This may be a wider range than the effectively achievable frequency range (see section 6 for PLL specification).

To achieve a frequency ramp from 58 GHz to 63.5 GHz in 36  $\mu\text{s}$ , the FSU register is programmed to:

$$N_{FSU} = 2^{20} \left[ \frac{58 \text{ GHz}}{640 \text{ MHz}} - 96 \right] = -5636096 \hat{=} AA0000_{hex}$$

The ramp time bit field RTU is programmed to:

$$N_{RTU} = \frac{t_{ramp}}{8 \cdot T_{SYSCLK}} = 36 \mu\text{s} \frac{80 \text{ MHz}}{8} = 360.$$

The frequency increment per clock cycle result to:

$$\Delta f_{RF} = \frac{f_{RF,end} - f_{RF,start}}{8 \cdot N_{RTU}} = \frac{63.5 \text{ GHz} - 58 \text{ GHz}}{8 \cdot 360} = \frac{5.5 \text{ GHz}}{2880} = 1.9097\bar{2} \text{ MHz}.$$

Accordingly, the bit field RSU is programmed to:

$$N_{RSU} = 2^{20} \frac{1.9097\bar{2} \text{ MHz}}{640 \text{ MHz}} = 3128.\bar{8} \hat{=} 3128 \hat{=} 000C38_{hex}$$

Due to rounding errors from the above calculation, the ramp will end at a slightly different end frequency:

$$f_{RF,end} = f_{RF,start} + 8 \cdot N_{RTU} \cdot \frac{640 \text{ MHz}}{2^{20}} N_{RSU} = 63.4984375 \text{ GHz}.$$

## Shapes, Frames, and Channel Set Definition

### PLL Setup Example 2 ( $f_{SYSCLK} = 76.8 \text{ MHz}$ )

With a reference clock frequency of 76.8 MHz the recommended value for  $N_{DIVSET}$  is 21. With these parameters the conversion formulas simplify to:

$$N_{FSU} = 2^{20} \left[ \frac{f_{RF}}{614.4 \text{ MHz}} - 100 \right]$$

and

$$N_{RSU} = 2^{20} \frac{\Delta f_{RF}}{614.4 \text{ MHz}}$$

With the PLL's 24 bit 2's complement frequency registers the total programmable RF frequency range is  $56.5248 \text{ GHz} \leq f_{RF} \leq 66.3552 \text{ GHz}$ . This may be a wider range than the effectively achievable frequency range (see section 6 for PLL specification).

To achieve a frequency ramp from 58 GHz to 63.5 GHz in  $36 \mu\text{s}$ , the FSU register is programmed to:

$$N_{FSU} = 2^{20} \left[ \frac{58 \text{ GHz}}{614.4 \text{ MHz}} - 100 \right] = -5870933.\bar{3} \cong -5870933 \cong A66AAB_{hex}.$$

The ramp time bit field RTU is programmed to:

$$N_{RTU} = \frac{t_{ramp}}{8 \cdot T_{SYSCLK}} = 36 \mu\text{s} \frac{76.8 \text{ MHz}}{8} = 345.6 \cong 346.$$

The frequency increment per clock cycle result to:

$$\Delta f_{RF} = \frac{f_{RF,end} - f_{RF,start}}{8 \cdot N_{RTU}} = \frac{63.5 \text{ GHz} - 58 \text{ GHz}}{8 \cdot 346} = \frac{5.5 \text{ GHz}}{2768} = 1.986994 \text{ MHz}.$$

Accordingly the bit field RSU is programmed to:

$$N_{RSU} = 2^{20} \frac{1.986994 \text{ MHz}}{614.4 \text{ MHz}} = 3391.13680 \cong 3391 \cong 000D3F_{hex}.$$

Due to rounding errors from the above calculation, the ramp will end at a slightly different end frequency:

$$f_{RF,start} = 614.4 \text{ MHz} \left[ 100 + \frac{N_{FSU}}{2^{20}} \right] = 58.0000002 \text{ GHz}$$

$$f_{RF,end} = f_{RF,start} + 8 \cdot N_{RTU} \cdot \frac{614.4 \text{ MHz}}{2^{20}} N_{RSU} = 63.499778315 \text{ GHz}.$$



## BGT60TR13C Registers

### 4 BGT60TR13C Registers

An array of registers visible via the SPI is used to control and program the states of the different blocks inside the chip.

#### 4.1 Register List

The registers are arranged in blocks of 24 bits each. Each block is identified by its unique address. The registers are accessed from the SPI module. The bit fields from each register are arranged in MSB first order.

**Table 20** The following table gives an overview on the BGT60TR13C registers. Register Overview / Address Table

Register Address	Register Name	Description	RST	Section
0x00	MAIN	Main register		4.2
0x01	ADC0	MADC control register		4.3
0x02	CHIP_ID	Digital and RF version		4.3
0x03	STAT1	Status register 1		4.5
0x04	PACR1	PLL analog control register 1		4.6
0x05	PACR2	PLL analog control register 2		4.7
0x06	SFCTL	SPI and FIFO Control		4.8
0x07	SADC_CTRL	Sensor ADC ctrl reg		4.9
0x08	CSI_0	Channel set idle mode 0		4.10
0x09	CSI_1	Channel set idle mode 1		4.10
0x0A	CSI_2	Channel set idle mode 2		4.10
0x0B	CSCI	Channel set control idle mode		4.11
0x0C	CSDS_0	Channel set deep sleep mode 0		4.10
0x0D	CSDS_1	Channel set deep sleep mode 1		4.10
0x0E	CSDS_2	Channel set deep sleep mode 2		4.10
0x0F	CSCDS	Channel set control deep sleep mode		4.11
0x10	CSU1_0	Channel set 1 (up)		4.10
0x11	CSU1_1	Channel set 1 (up)		4.10
0x12	CSU1_2	Channel set 1 (up)		4.10
0x13	CSD1_0	Channel set 1 (down)		4.10
0x14	CSD1_1	Channel set 1 (down)		4.10
0x15	CSD1_2	Channel set 1 (down)		4.10
0x16	CSC1	Channel set control 1 (up/dn)		4.11
0x17	CSU2_0	Channel set 2 (up)		4.10
0x18	CSU2_1	Channel set 2 (up)		4.10
0x19	CSU2_2	Channel set 2 (up)		4.10
0x1A	CSD2_0	Channel set 2 (down)		4.10
0x1B	CSD2_1	Channel set 2 (down)		4.10
0x1C	CSD2_2	Channel set 2 (down)		4.10

## BGT60TR13C Registers

0x1D	CSC2	Channel set control 2 (up/dn)	4.11
0x1E	CSU3_0	Channel set 3 (up)	4.10
0x1F	CSU3_1	Channel set 3 (up)	4.10
0x20	CSU3_2	Channel set 3 (up)	4.10
0x21	CSD3_0	Channel set 3 (down)	4.10
0x22	CSD3_1	Channel set 3 (down)	4.10
0x23	CSD3_2	Channel set 3 (down)	4.10
0x24	CSC3	Channel set control 3 (up/dn)	4.11
0x25	CSU4_0	Channel set 4 (up)	4.10
0x26	CSU4_1	Channel set 4 (up)	4.10
0x27	CSU4_2	Channel set 4 (up)	4.10
0x28	CSD4_0	Channel set 4 (down)	4.10
0x29	CSD4_1	Channel set 4 (down)	4.10
0x2A	CSD4_2	Channel set 4 (down)	4.10
0x2B	CSC4	Channel set control 4 (up/dn)	4.11
0x2C	CCR0	Chirp control register 0	4.12
0x2D	CCR1	Chirp control register 1	4.13
0x2E	CCR2	Chirp control register 2	4.14
0x2F	CCR3	Chirp control register 3	4.15
0x30	PLL1_0	FSU1 – shape 1	4.16
0x31	PLL1_1	RSU1 – shape 1	4.16
0x32	PLL1_2	RTU1 – Shape 1	4.16
0x33	PLL1_3	AP1 – shape 1	4.16
0x34	PLL1_4	FSD1 – shape 1	4.16
0x35	PLL1_5	RSD1 – shape 1	4.16
0x36	PLL1_6	RTD1 – shape 1	4.16
0x37	PLL1_7	SCR – shape 1	4.17
0x38	PLL2_0	FSU1 – shape 2	4.16
0x39	PLL2_1	RSU1 – shape 2	4.16
0x3A	PLL2_2	RTU1 – shape 2	4.16
0x3B	PLL2_3	AP1 – shape 2	4.16
0x3C	PLL2_4	FSD1 – shape 2	4.16
0x3D	PLL2_5	RSD1 – shape 2	4.16
0x3E	PLL2_6	RTD1 – shape 2	4.16
0x3F	PLL2_7	SCR – shape 2	4.17
0x40	PLL3_0	FSU1 – shape 3	4.16
0x41	PLL3_1	RSU1 – shape 3	4.16
0x42	PLL3_2	RTU1 – shape 3	4.16
0x43	PLL3_3	AP1 – shape 3	4.16
0x44	PLL3_4	FSD1 – shape 3	4.16
0x45	PLL3_5	RSD1 – shape 3	4.16

**BGT60TR13C Registers**

0x46	PLL3_6	RTD1 – shape 3	4.16
0x47	PLL3_7	SCR – shape 3	4.17
0x48	PLL4_0	FSU1 – shape 4	4.16
0x49	PLL4_1	RSU1 – shape 4	4.16
0x4A	PLL4_2	RTU1 – shape 4	4.16
0x4B	PLL4_3	AP1 – shape 4	4.16
0x4C	PLL4_4	FSD1 – shape 4	4.16
0x4D	PLL4_5	RSD1 – shape 4	4.16
0x4E	PLL4_6	RTD1 – shape 4	4.16
0x4F	PLL4_7	SCR – shape 4	4.17
0x55	RFT0	RF test register 0	4.19
0x56	RFT1	RSVD	4.20
0x59	PLL_DFT0	PLL DFT register 0	4.18
0x5D	STAT0	Status register 0	4.21
0x5E	SADC_RESULT	Sensor ADC result register	4.22
0x5F	FSTAT	FIFO status register	4.23
>= 0x60		FIFO access	

Note: Reserved bits (RSVD) in the registers should not be modified. They should be kept in the default/reset state unless otherwise specified.

**4.1.1 Abbreviations**

Access modes on the registers:

- R ... Readable register or bit field
- W ... Writeable register or bit field
- S ... Status bit can be set to readable mode “R”
- RSVD ... Reserved value which is not assigned at the moment

**4.2 MAIN – Main Register**

This register controls the top-level behavior of the chip.

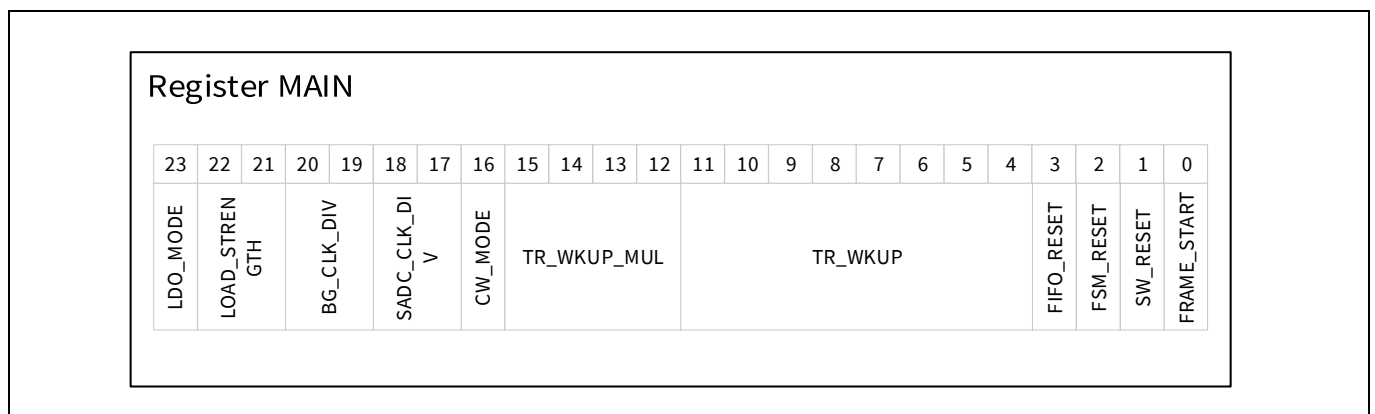

Figure 19 MAIN register

## BGT60TR13C Registers

Table 21 MAIN: Register Description

Symbol	Bits	Type	Description	RST
LDO_MODE	23	RW	The LDO settling time is defined by the LDO_MODE: 0 <sub>B</sub> ... Low power (50 µA), slow settling time 1 <sub>B</sub> ... High power (100 µA), fast settling time	0 <sub>B</sub>
LOAD_STRENGTH	22:21	RW	Current spikes, overshoots and undershoots can occur on the VDDC during FSM transitions. Those can be smooth by applying a dummy load at the output of the LDO: 0 <sub>D</sub> ... Disabled 1 <sub>D</sub> ... 100 µA (current in the dummy load) 2 <sub>D</sub> ... 200 µA (current in the dummy load) 3 <sub>D</sub> ... 400 µA (current in the dummy load)	0 <sub>D</sub>
BG_CLK_DIV	20:19	RW	Bandgap clock divider Bandgap clock frequency divider value: 0 <sub>D</sub> ... Bandgap clock off 1 <sub>D</sub> ... Divider value is 1 2 <sub>D</sub> ... Divider value is 2 3 <sub>D</sub> ... Divider value is 4 Note: not “clock tree balanced”	3 <sub>D</sub>
SADC_CLKDIV	18:17	RW	SADC clock divider provides the system clock for the sensing ADC. The divider value is defined as: 0 <sub>D</sub> ... SADC clock off 1 <sub>D</sub> ... Divider value is 1 2 <sub>D</sub> ... Divider value is 2 3 <sub>D</sub> ... Divider value is 4	3 <sub>D</sub>
CW_MODE	16	RW	Set to 1 <sub>B</sub> : “Continuous Wave” mode: no shapes are executed but PLL / RF / ADC runs with values programmed in PDFT[0,1] registers and CS1.	0 <sub>B</sub>
TR_WKUP_MUL	15:12	RW	Timer multiplier factor for wake-up time delay T_WU. Precise formula provided under MAIN:TR_WKUP.	0 <sub>D</sub>
TR_WKUP	11:4	RW	Coefficient to calculate T_WU: 0 <sub>D</sub> ... T <sub>SYS_CLK</sub> From 1 <sub>D</sub> to 255 <sub>D</sub> the time delay T_WU is calculated as follows: $T\_WU = (TR\_WKUP \times 2^{TR\_WKUP\_MUL \times 8 + TR\_WKUP\_MUL + 3}) \times T_{SYS\_CLK}$ In typical use-case T_WUTYP= 1ms.	0 <sub>D</sub>
FIFO_RESET	3	W	Clears and resets data_fifo: 0 <sub>B</sub> ... No change 1 <sub>B</sub> ... Reset the FIFO and return back to 0	0 <sub>B</sub>
FSM_RESET	2	W	Control FSM reset: 0 <sub>B</sub> ... No change 1 <sub>B</sub> ... Reset the control FSM and return back to 0 <sub>B</sub>	0 <sub>B</sub>
SW_RESET	1	W	Software reset:	0 <sub>B</sub>

**BGT60TR13C Registers**

Symbol	Bits	Type	Description	RST
			0 <sub>B</sub> ... No change 1 <sub>B</sub> ... Reset the register settings and return back to 0 <sub>B</sub>	
FRAME_START	0	W	Starts frame generation. After the frame generation is started writing 1 <sub>B</sub> : 0 <sub>B</sub> ... No effect 1 <sub>B</sub> ... Starts the frame generation It can be stopped by an FSM_RESET.	0 <sub>B</sub>

**4.3 ADC0 – MADC Control Register**

The bits in this register are used to set properly the ADCs in the Rx chain.

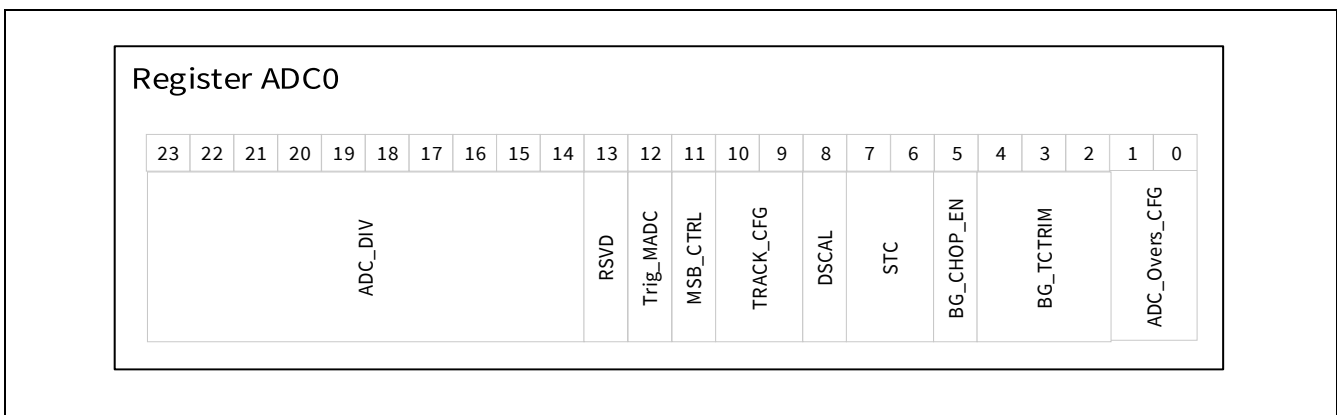

Figure 20 ADC0 register

Table 22 ADC0: Register Description

Symbol	Bits	Type	Description	RST
ADC_DIV	23:14	RW	Sampling frequency divider value. The actual sampling frequency will be $f_{ADC\_SAMP} = f_{ADC\_CLK} / ADC\_DIV$ : 20 <sub>D</sub> ... minimum divider value → $f_{ADC\_SAMP} = 4$ Msps 33 <sub>D</sub> ... typical value → $f_{ADC\_SAMP} = 2.42$ Msps 1023 <sub>D</sub> ... max divider value → $f_{ADC\_SAMP} = 78.201$ kpsps	40 <sub>D</sub>
RSVD	13	RW	RSVD	0 <sub>B</sub>
TRIG_MADC	12	W	Test mode feature for single measurement acquisition. The results can be read through the test bits in registers ADC1 to ADC4: 0 <sub>B</sub> ... Return value after trigger is captured internally 1 <sub>B</sub> ... Single trigger event	0 <sub>B</sub>
MSB_CTRL	11	RW	MSB decision time selection during calibration and conversion: 0 <sub>B</sub> ... Single MSB decision time 1 <sub>B</sub> ... Doubled MSB decision time	0 <sub>B</sub>
TRACK_CFG	10:9	RW	Tracking conversion configuration bits: 0 <sub>D</sub> ... No sub conversions are executed and averaged 1 <sub>D</sub> ... 1 sub conversion 2 <sub>D</sub> ... 3 sub conversions	1 <sub>D</sub>

**BGT60TR13C Registers**

Symbol	Bits	Type	Description	RST
			3 <sub>D</sub> ... 7 sub conversions	
DSCAL	8	RW	Disable Startup calibration: 0 <sub>B</sub> ... startup calibration is enabled 1 <sub>B</sub> ... startup calibration is disabled	0 <sub>B</sub>
STC	7:6	RW	Sample time control: 0 <sub>D</sub> ... 50 ns 1 <sub>D</sub> ... 100 ns 2 <sub>D</sub> ... 200 ns 3 <sub>D</sub> ... 400 ns	1 <sub>D</sub>
BG_CHOP_EN	5	RW	Enable chopping within the bandgap. 0 <sub>B</sub> ... No chopping enabled 1 <sub>B</sub> ... Chopping enabled	0 <sub>B</sub>
BG_TC_TRIM	4:2	RW	Static temperature coefficient trimming 0 <sub>D</sub> ... Min. value 7 <sub>D</sub> ... Max. value	0 <sub>D</sub>
ADC_OVERS_CFG	1:0	RW	Oversampling configuration: 0 <sub>D</sub> ... Standard single 11 bits conversion 1 <sub>D</sub> ... Reserved 2 <sub>D</sub> ... Reserved 3 <sub>D</sub> ... Reserved Note: Oversampling must be set to 0 <sub>D</sub>	0 <sub>D</sub>

**4.4 CHIP\_ID**

The register CHIP\_ID provides information regarding the digital code version, the RF block version, and the antenna configuration (number of channels, position of the antennas e.g.).

It is used by the driver to configure the device properly according to the information above.

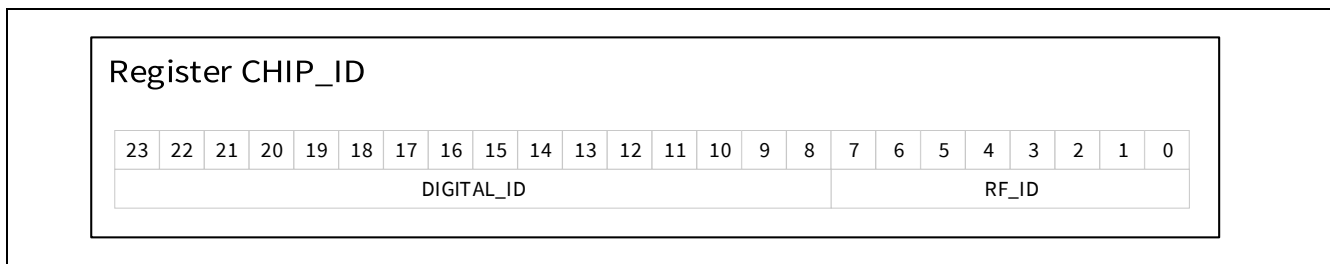

Figure 21 CHIP\_ID register

Table 23 CHIP\_ID: Register Description

Symbol	Bits	Type	Description	RST
DIGITAL_ID	23:8	R	3 <sub>D</sub>	3 <sub>D</sub>
RF_ID	7:0	R	3 <sub>D</sub> ... 1ch Tx, 3ch Rx	3 <sub>D</sub>

The Digital\_ID as well as the RF\_ID will be incremented according to the latest chip release/version.

**BGT60TR13C Registers**

**4.5 STAT1 - Status Register1**

The status register provides internal counter values for the actual number of frames and shapes. They are also provided to the data header. However, it should be mentioned that for all status registers, STAT0, STAT1, and FSTAT, with the exception of the FIFO status and error flags, updates to each status register field can happen on different timing events relative to FSM states and the field content should be treated independently from one-another. In CW mode the status bits can be read properly after eg. 100 µs.

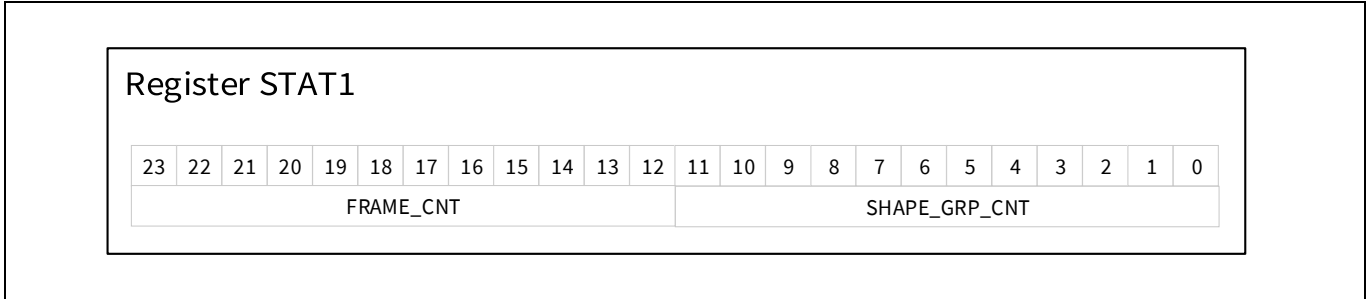

**Figure 22 STAT1: status register 1**

**Table 24 STAT1: Register Description**

Symbol	Bits	Type	Description	RST
FRAME_CNT	23:12	R	Frame counter value: 0 <sub>D</sub> ... Reset value / after max. value rollover 4095 <sub>D</sub> ... Max. value Note: This field is for debug only. Note: FRAME_CNT info should not be used when endless mode enabled (please check CCR2:MAX_FRAME_CNT).	0 <sub>D</sub>
SHAPE_GRP_CNT	11:0	R	Shape group counter counts the actual shape groups: 0 <sub>D</sub> ... Reset value / after max. value for SHAPE_GRP_CNT reached 4095 <sub>D</sub> ... Max. value	0 <sub>D</sub>

Note:

1. A shape consists of an “Up Chirp” segment and a “Down Chirp” segment.
2. A saw-tooth shape is generated by an “Up Chirp” and a “Fast Down Chirp”.
3. There is no data acquisition in the “Fast Down Chirp”.

## BGT60TR13C Registers

## 4.6 PACR1: PLL Analog Control Registers 1

The bits in this register are used to properly set the PLL.

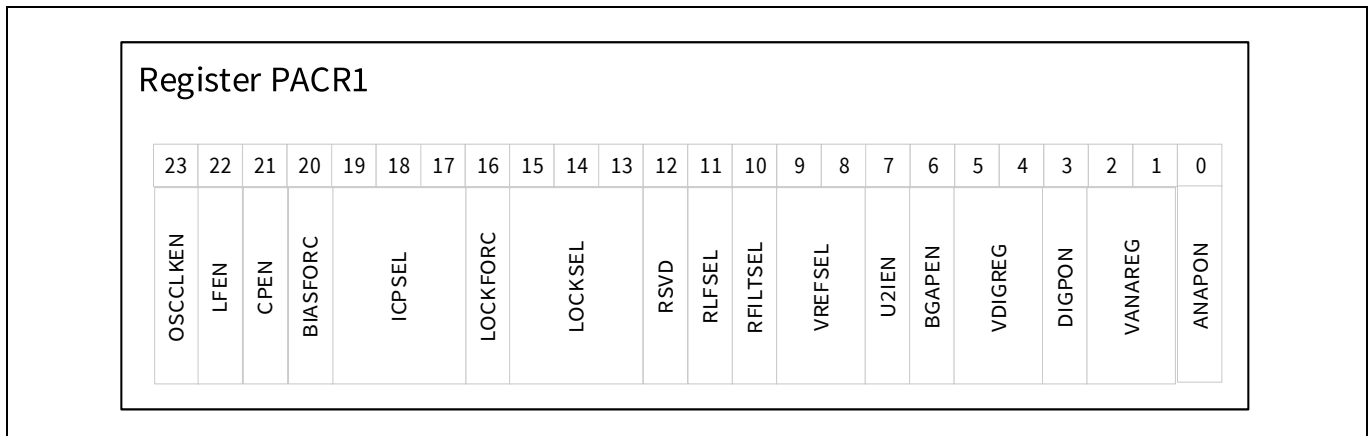

Figure 23 PACR1 register

Table 25 PACR1: Register Description

Symbol	Bits	Type	Description	RST
OSCCLKEN	23	RW	Enable clock path for system clock: 0 <sub>B</sub> ... Clock off 1 <sub>B</sub> ... Clock path active by default this is disabled This bit is controlled by FSM during operation. After deep sleep this bit should be enabled by the host. Before the MAIN: FRAME_START is raised the OSCCLKEN should be enabled!	0 <sub>B</sub>
LFEN	22	RW	Enable loop filter: 0 <sub>B</sub> ... Off(default) 1 <sub>B</sub> ... On	0 <sub>B</sub>
CPEN	21	RW	Enable charge pump: 0 <sub>B</sub> ... Off(default) 1 <sub>B</sub> ... On	0 <sub>B</sub>
BIASFORC	20	RW	Use fixed biasing inside charge pump (= disable bias reg. loop): 0 <sub>B</sub> ... Fixed biasing off = bias regulation loop active (default) 1 <sub>B</sub> ... Fixed biasing on = bias regulation loop deactivated	1 <sub>B</sub>
ICPSEL	19:17	RW	Select charge pump current: 0 <sub>D</sub> ... 40 μA 1 <sub>D</sub> ... 80 μA 2 <sub>D</sub> ... 120 μA 3 <sub>D</sub> ... 160 μA 4 <sub>D</sub> ... 200 μA (default) 5 <sub>D</sub> ... 240 μA 6 <sub>D</sub> to 7 <sub>D</sub> ... 280 μA	4 <sub>D</sub>
LOCKFORC	16	RW	Force lock signal to high: 0 <sub>B</sub> ... Lock signal not forced 1 <sub>B</sub> ... Lock forced to high	1 <sub>B</sub>





BGT60TR13C Registers

4.7 PACR2: PLL Analog Control Registers 2

The bits in this register are used to properly set the PLL.

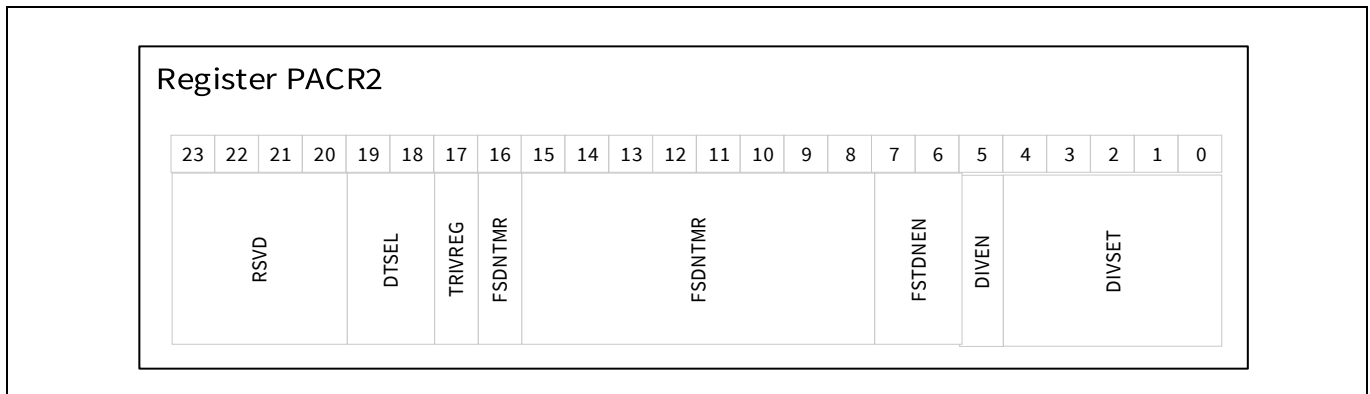

Figure 24 PACR2 PLL register

Table 26 PACR2: Register Description

Symbol	Bits	Type	Description	RST
RSVD	23:20	RW	Reserved	0 <sub>D</sub>
DTSEL	19:18	RW	Set PFD dead time / dead zone: 0 <sub>D</sub> ... 180 ps to 350 ps 1 <sub>D</sub> ... 270 ps to 510 ps (default) 2 <sub>D</sub> ... 360 ps to 680 ps 3 <sub>D</sub> ... 450 ps to 840 ps	1 <sub>D</sub>
TRIVREG	17	RW	Set regulator off-state to tristate (for both ana- & dig-regulator): 0 <sub>B</sub> ... Off state is 0.0V (default) 1 <sub>B</sub> ... Off state is to tristate (setting active for dig-regulator if DIGPON = 0 <sub>B</sub> ; setting active for ana-regulator if ANAPON= 0 <sub>B</sub> )	0 <sub>B</sub>
FSDNTMR	16:8	RW	Defines the time for the PLL loop filter discharge during fast down chirp operation. When FSDNTMR = 0 <sub>D</sub> and FSTDNEN is ≠ 0 <sub>D</sub> , the fast down chirp length is internally assigned to a default value (@typ f <sub>SYS_CLK</sub> ): 0 <sub>D</sub> ... 500 ns if FSTDNEN = 1 <sub>D</sub> (discharge of the loop filter to the reference voltage set to PACR2:VREFSEL) 0 <sub>D</sub> ... 700 ns if FSTDNEN = 2 <sub>D</sub> (discharge of the loop filter in a defined time window) 0 <sub>D</sub> ... 300 ns if FSTDNEN = 3 <sub>D</sub> For FSDNTMR > 0 <sub>D</sub> the discharge time will be T <sub>SYS_CLK</sub> × (FSDNTMR+1): 1 <sub>D</sub> ... 25 ns 2 <sub>D</sub> ... 37.5 ns ... 511 <sub>D</sub> ... 6.4 μs Suggested settings for the discharge time:	0 <sub>D</sub>

**BGT60TR13C Registers**

			PACR2:FSDNTMR= 5 <sub>D</sub> Together with: PACR2:FSTDNEN= 2 <sub>D</sub>  Depending on the specific modulation bandwidth set, specific settings can be defined.	
FSTDNEN	7:6	W	Fast-down chirp enabled (see note below): 00 <sub>B</sub> ... Disable (default) 01 <sub>B</sub> ... Enable fast down chirp (mode 1) 10 <sub>B</sub> ... Enable fast down chirp (mode 2) 11 <sub>B</sub> ... Enable fast down chirp (mode 3)  Suggested settings for the fast-down mode (active mode between chirps): PACR2:FSDNTMR = 5 <sub>D</sub> Together with: PACR2:FSTDNEN = 2 <sub>D</sub>  Depending on the specific modulation bandwidth set, specific settings can be defined.	00 <sub>B</sub>
DIVEN	5	RW	Enable divider: 0 <sub>B</sub> ... Off: Input clock of divider and 80 MHz clock gated 1 <sub>B</sub> ... On: clocks released	0 <sub>B</sub>
DIVSET	4:0	RW	Set fixed part of integer division factor (consider offset of  2 ) Default = 20 <sub>D</sub> , valid for a 80 MHz system clock. 21 <sub>D</sub> should be used for a 76.8 MHz system clock.	20 <sub>D</sub>

Note:

*This bit field is typically used by the FSM. In case not used, the FSM switches the bit field back to the default value.*

**4.8 SFCTL – SPI and FIFO Control Register**

This register is used to configure the SPI and FIFO.

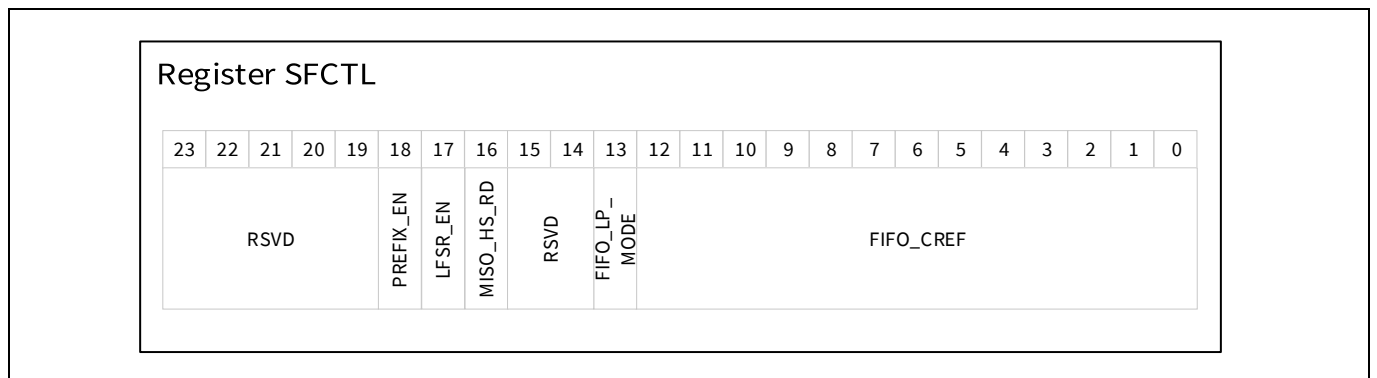

**Figure 25 SPI and FIFO Control Register**

## BGT60TR13C Registers

Table 27 SPI and FIFO Control: Register Description

Symbol	Bits	Type	Description	RST
RSVD	23:19	RW	RSVD	14 <sub>B</sub>
PREFIX_EN	18	RW	Enables the data header written into the FIFO prior to the sampling data of each chirp: 0 <sub>B</sub> ... No prefix data header prior to chirp data 1 <sub>B</sub> ... Prefix data header added prior to chirp data (see section 5.1 for data header)	0 <sub>B</sub>
LFSR_EN	17	RW	Enable LFSR register data generation: 0 <sub>B</sub> ... Normal data acquisition, LFSR reset 1 <sub>B</sub> ... LFSR data generation started LFSR should be enabled after a FIFO reset to ensure an empty FIFO (see also 5.10).	0 <sub>B</sub>
MISO_HS_RD	16	RW	0 <sub>B</sub> ... MISO data is sent with falling edge of SPI CLK 1 <sub>B</sub> ... MISO data is sent with rising edge ( ½ cycle earlier )  Note: HS_RD = 0 <sub>B</sub> can only be used for a SPI clock < 25 MHz. For HS-transfer please check the timing of the SPI Master and adjust settings accordingly.  The setting becomes active when the last bit of FSCTL is clocked out and it affects MISO immediately. See also section 5.3.1.	1 <sub>B</sub>
RSVD	15:14	RW	RSVD	0 <sub>B</sub>
FIFO_LP_MODE	13	RW	FIFO power mode: 0 <sub>B</sub> ... FIFO permanently enabled 1 <sub>B</sub> ... FIFO activated dynamically	0 <sub>B</sub>
FIFO_CREF	12:0	RW	FIFO compare reference: it defines the compare filling status for interrupt and CREF reporting When filling status is > FIFO_CREF an interrupt is issued: 0 <sub>D</sub> ... minimum value is 0, interrupt generated in case first sample is written into FIFO 8191 <sub>D</sub> ... maximum value in case FIFO is full with 8192 memory locations eg. CREF = 0x1000 represents a 50% compare reference	0 <sub>D</sub>

### 4.9 SADC\_CTRL Sensor ADC Control Register

The bits in this register are used to properly set the sensor ADC (SADC) used to monitor the on-chip sensor outputs, temperature and power, as well as some internal voltage nodes.

BGT60TR13C Registers

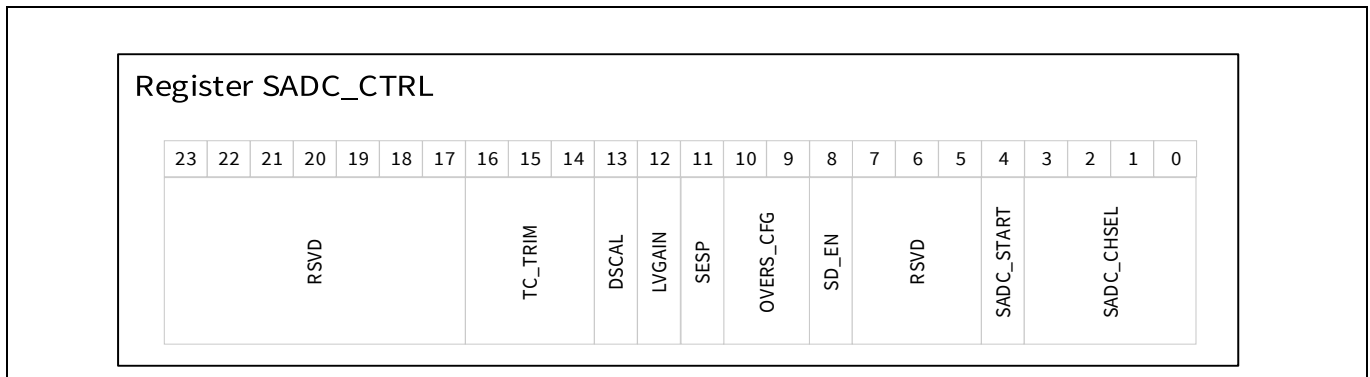

Figure 26 SADC\_CRTL registers

Table 28 SADC\_CRTL: Register Description

Symbol	Bits	Type	Description	RST
RSVD	23:17	RW	RSVD	0 <sub>D</sub>
TC_TRIM	16:14	RW	Bandgap trim value: 0 <sub>D</sub> ... Min. trim value 7 <sub>D</sub> ... Max. trim value	0 <sub>D</sub>
DSCAL	13	RW	Disable startup calibration: 0 <sub>B</sub> ... Startup calibration enabled 1 <sub>B</sub> ... startup calibration disabled	0 <sub>B</sub>
LVGAIN	12	RW	Sample configuration for LV channels: 0 <sub>B</sub> ... Gain = 1.0 1 <sub>B</sub> ... Gain = 0.75	0 <sub>B</sub>
SESP	11	RW	Spreaded early sampling point enable: 0 <sub>B</sub> ... Disabled 1 <sub>B</sub> ... Enabled	0 <sub>B</sub>
OVERS_CFG	10:9	RW	Oversampling configuration: 0 <sub>D</sub> ... No oversampling → 8 bits resolution 1 <sub>D</sub> ... Oversampling by 2 2 <sub>D</sub> ... Oversampling by 4 → 9 bits resolution 3 <sub>D</sub> ... Oversampling by 32 → 10 bits resolution	0 <sub>D</sub>
SD_EN	8	RW	Sigma delta loop enable: 0 <sub>B</sub> ... Disabled 1 <sub>B</sub> ... Enabled	0 <sub>B</sub>
RSVD	7:5	RW	RSVD	0 <sub>D</sub>
SADC_START	4	W	SADC trigger: 1 <sub>B</sub> ... Trigger the SADC to start a measurement 0 <sub>B</sub> ... Default value or value after the trigger is captured; internally the value is set back to SADC_START= 0 <sub>B</sub> .	0 <sub>B</sub>
SADC_CHSEL	3:0	RW	Analog multiplexer input for channel selection into the SADC: 0 <sub>D</sub> ... Temperature Sensor 1 <sub>D</sub> ... RSVD	0 <sub>D</sub>

BGT60TR13C Registers

Table 28 SADC\_CTRL: Register Description

Symbol	Bits	Type	Description	RST
			2 <sub>D</sub> ... Temperature Sensor reference 3 <sub>D</sub> ... pd_outx 4 <sub>D</sub> ... pd_out 5 <sub>D</sub> ... ifx_mix3 6 <sub>D</sub> ... if_mix3 7 <sub>D</sub> ... ifx_mix2 8 <sub>D</sub> ... if_mix2 9 <sub>D</sub> ... ifx_mix1 10 <sub>D</sub> ... if_mix1 11-15 <sub>D</sub> ... RSVD	

4.10 CSx: Channel Set Registers

The channel set registers together with the channel set control registers defines the RF and baseband behavior during the shapes. CSUx= Channel Set Upchirp, CSDx= Channel Set Downchirp, CSI= Channel Set Idle, CSDS= Channel Set Deep Sleep.

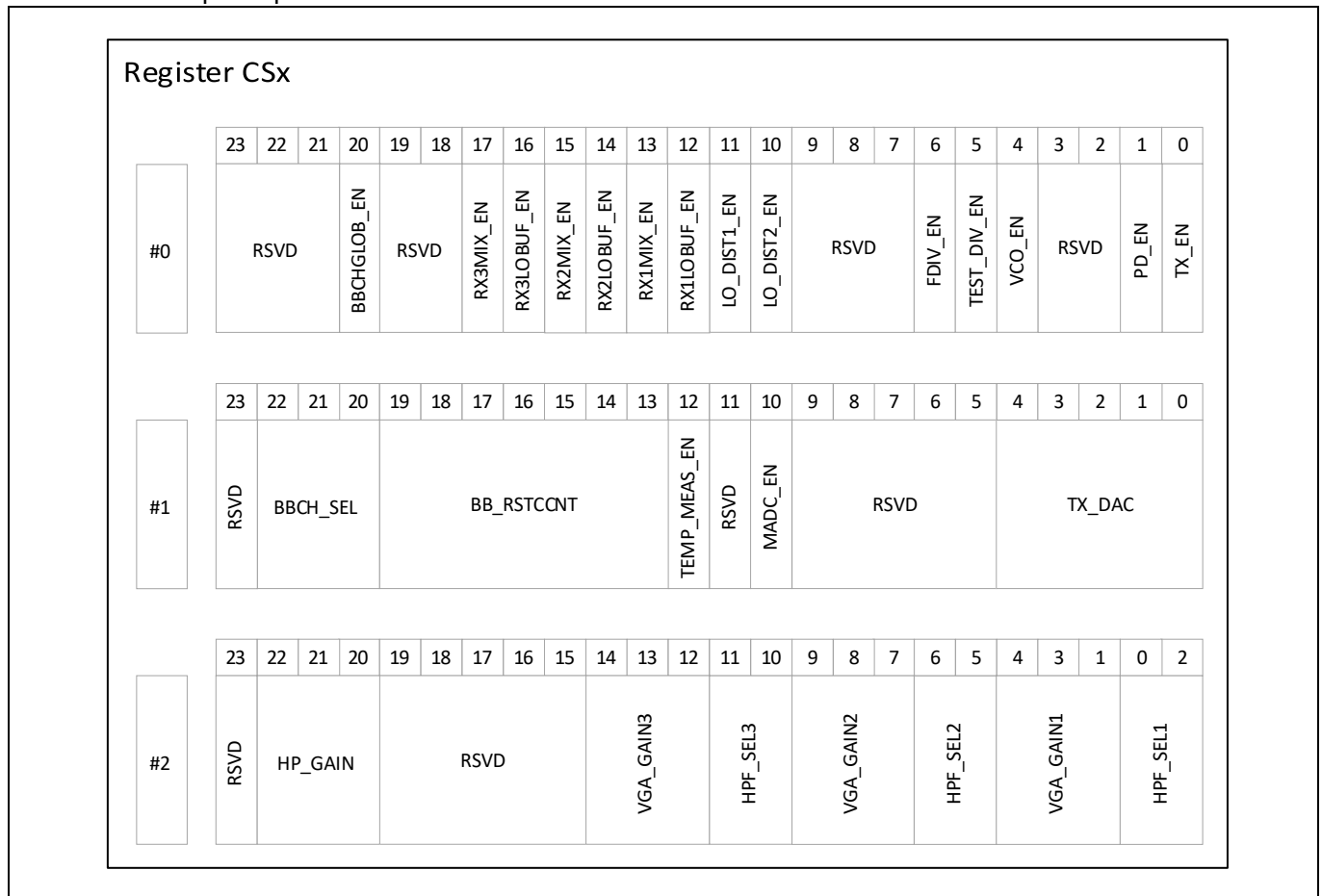

Figure 27 Channel Set Registers

## BGT60TR13C Registers

Table 29 CSx#0: Register Description

Symbol	Bits	Type	Description	RST
RSVD	23:21	RW	RSVD	0 <sub>D</sub>
BBCHGLOB_EN	20	RW	Enables the baseband chain together with the bit BBCH_SEL: 0 <sub>B</sub> ... Baseband channels are disabled 1 <sub>B</sub> ... Baseband channels are enabled	0 <sub>B</sub>
RSVD	19:18	RW	RSVD	0 <sub>D</sub>
RX3MIX_EN	17	RW	Enable the mixer on ch3: 0 <sub>B</sub> ... Disabled 1 <sub>B</sub> ... Enabled	0 <sub>B</sub>
RX3LOBUF_EN	16	RW	Enable the local oscillator buffer to the mixer on ch3: 0 <sub>B</sub> ... Disabled 1 <sub>B</sub> ... Enabled	0 <sub>B</sub>
RX2MIX_EN	15	RW	Enable the mixer on ch2: 0 <sub>B</sub> ... Disabled 1 <sub>B</sub> ... Enabled	0 <sub>B</sub>
RX2LOBUF_EN	14	RW	Enable the local oscillator buffer to the mixer on ch2: 0 <sub>B</sub> ... Disabled 1 <sub>B</sub> ... Enabled	0 <sub>B</sub>
RX1MIX_EN	13	RW	Enable the mixer on ch1: 0 <sub>B</sub> ... Disabled 1 <sub>B</sub> ... Enabled	0 <sub>B</sub>
RX1LOBUF_EN	12	RW	Enable the local oscillator buffer to the mixer on ch1: 0 <sub>B</sub> ... Disabled 1 <sub>B</sub> ... Enabled	0 <sub>B</sub>
LO_DIST1_EN (formerly LO_DISTRIB_EN)	11	RW	Enable the local oscillator distribution buffer to the RX2 and TX channels: 0 <sub>B</sub> ... Disabled 1 <sub>B</sub> ... Enabled	0 <sub>B</sub>
LO_DIST2_EN (formerly LO_MOD1_EN)	10	RW	Enable the local oscillator distribution buffer to the RX1 and RX3 channels: 0 <sub>B</sub> ... Disabled 1 <sub>B</sub> ... Enabled	0 <sub>B</sub>
RSVD	9:7	RW	RSVD	0 <sub>D</sub>
FDIV_EN	6	RW	Enable the VCO frequency divider: 0 <sub>B</sub> ... Disable the DIV output 1 <sub>B</sub> ... Enable the DIV output	0 <sub>B</sub>
TEST_DIV_EN	5	RW	Frequency divider test control bit: 0 <sub>B</sub> ... Disable the divider 1 <sub>B</sub> ... Enable the divider	0 <sub>B</sub>
VCO_EN	4	RW	Enable the VCO: 0 <sub>B</sub> ... Disabled	0 <sub>B</sub>

## BGT60TR13C Registers

Table 29 CSx#0: Register Description

Symbol	Bits	Type	Description	RST
			1 <sub>B</sub> ... Enabled	
RSVD	3:2	RW	RSVD	0 <sub>D</sub>
PD_EN	1	RW	Enable the power detector from TX: 0 <sub>B</sub> ... Disabled 1 <sub>B</sub> ... Enabled	0 <sub>B</sub>
TX_EN	0	RW	Enable the DAC and power amplifier of TX 0 <sub>B</sub> ... Disabled 1 <sub>B</sub> ... Enabled	0 <sub>B</sub>

Table 30 CSx#1: Register Description

Symbol	Bits	Type	Description	RST
RSVD	23	RW	RSVD	0 <sub>B</sub>
BBCH_SEL	22:20	RW	Enable the baseband filters, baseband amplifiers and ADCs on channel BBCHx, where x can be 1...3: BBCHx = 0 <sub>D</sub> ... channel disabled BBCHx = 1 <sub>D</sub> ... channel enabled CSx#1[22] ... BBCH3 CSx#1[21] ... BBCH2 CSx#1[20] ... BBCH1	0 <sub>D</sub>
BB_RSTCNT	19:13	RW	Baseband reset timer counter value for the analog baseband amplifiers. The reset counter will start together with the PAON signal after the T_PAEN timer. $BB\_RSTCNT = T_{BBRST} * f_{SYS\_CLK}$ 0 <sub>D</sub> ... No analog baseband reset 1 <sub>D</sub> ... Min. reset time is $T_{BBRST} = 12.5 \text{ ns}$ 127 <sub>D</sub> ... Max. reset counter, $T_{BBRST} = 1.5875 \mu\text{s}$	0 <sub>D</sub>
TEMP_MEAS_EN	12	RW	Enables the temperature sensor: 0 <sub>B</sub> ... Disabled 1 <sub>B</sub> ... Enabled	0 <sub>B</sub>
RSVD	11	RW	RSVD	0 <sub>B</sub>
MADC_EN	10	RW	Enable the three channel ADC module at once: 0 <sub>B</sub> ... ADC module powered down 1 <sub>B</sub> ... ADC module powered up	0 <sub>B</sub>
RSVD	9:5	RW	RSVD	0 <sub>D</sub>
TX_DAC	4:0	RW	TX power setting: 0 <sub>D</sub> ... Min. TX output power 31 <sub>D</sub> ... Max. TX output power	0 <sub>D</sub>

Table 31 CSx#2: Register Description

Symbol	Bits	Type	Description	RST
RSVD	23	RW	RSVD	0 <sub>B</sub>



## BGT60TR13C Registers

Table 30 CSx#1: Register Description

Symbol	Bits	Type	Description	RST
HP_GAIN	22:20	RW	Set the gain of the first stage: HPF GAIN[x]= 1 <sub>D</sub> ... 18dB Gain HPF GAIN[x]= 0 <sub>D</sub> ... 30dB gain bit20→ch1, bit21→ch2, bit22→ch3	0 <sub>D</sub>
RSVD	19:15	RW	RSVD	0 <sub>D</sub>
VGA_GAIN3	14:12	RW	VGA gain setting channel 3: 0 <sub>D</sub> ... 0dB gain 1 <sub>D</sub> ... 5dB gain 2 <sub>D</sub> ... 10dB gain 3 <sub>D</sub> ... 15dB gain 4 <sub>D</sub> ... 20dB gain 5 <sub>D</sub> ... 25dB gain 6 <sub>D</sub> ... 30dB gain 7 <sub>D</sub> ... RSVD	0 <sub>D</sub>
HPF_SEL3	11:10	RW	High pass filter channel 3 cutoff setting: 0 <sub>D</sub> ... 20kHz 1 <sub>D</sub> ... 45kHz 2 <sub>D</sub> ... 70kHz 3 <sub>D</sub> ... 80kHz	0 <sub>D</sub>
VGA_GAIN2	9:7	RW	VGA gain setting channel 2: 0 <sub>D</sub> ... 0dB gain 1 <sub>D</sub> ... 5dB gain 2 <sub>D</sub> ... 10dB gain 3 <sub>D</sub> ... 15dB gain 4 <sub>D</sub> ... 20dB gain 5 <sub>D</sub> ... 25dB gain 6 <sub>D</sub> ... 30dB gain 7 <sub>D</sub> ... RSVD	0 <sub>D</sub>
HPF_SEL2	6:5	RW	High pass filter channel 2 cutoff setting: 0 <sub>D</sub> ... 20kHz 1 <sub>D</sub> ... 45kHz 2 <sub>D</sub> ... 70kHz 3 <sub>D</sub> ... 80kHz	0 <sub>D</sub>
VGA_GAIN1	4:2	RW	VGA gain setting channel 1: 0 <sub>D</sub> ... 0dB gain 1 <sub>D</sub> ... 5dB gain 2 <sub>D</sub> ... 10dB gain 3 <sub>D</sub> ... 15dB gain 4 <sub>D</sub> ... 20dB gain 5 <sub>D</sub> ... 25dB gain 6 <sub>D</sub> ... 30dB gain 7 <sub>D</sub> ... RSVD	0 <sub>D</sub>

BGT60TR13C Registers

Table 30 CSx#1: Register Description

Symbol	Bits	Type	Description	RST
HPF_SEL1	1:0	RW	High pass filter channel 1 cutoff setting: 0 <sub>D</sub> ... 20kHz 1 <sub>D</sub> ... 45kHz 2 <sub>D</sub> ... 70kHz 3 <sub>D</sub> ... 80kHz	0 <sub>D</sub>

4.11 CSCx - Channel Set Control Register

The channel set control register CSCx is related to the channel set register CSUx and CSDx as well as to CSI and CSDS, see description in section 4.10.

Besides REPC, all other bits are used to define a specific power mode.

“\_ISOPD” represents a logical isolation layer used to disable one main block (MADC e.g.) preserving its configuration (no change in the ADC0 register configuration e.g.).

REPC is one parameter used to define the modulation sequence, see also 3.2.

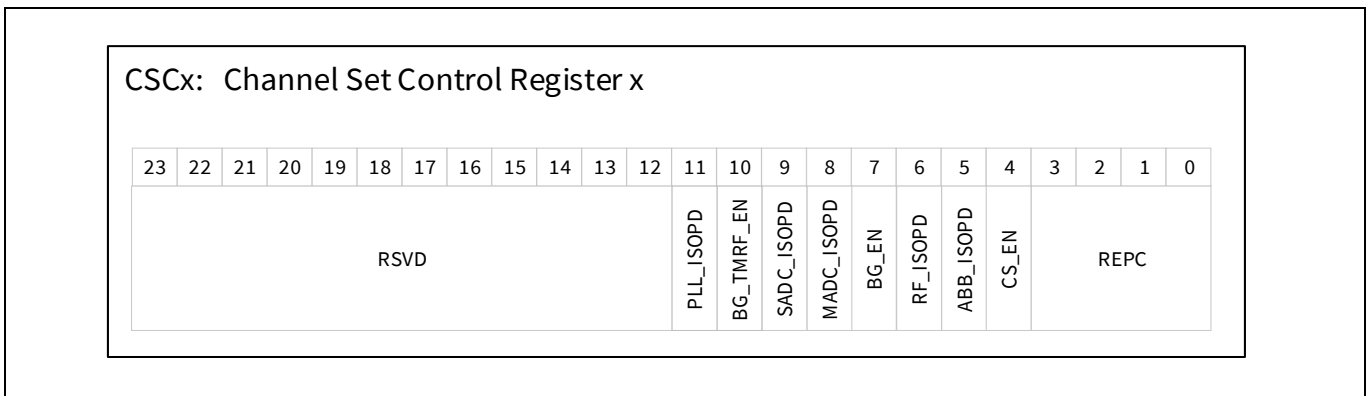

Figure 28 Channel Set Control Register

Table 32 CSCx: Register Description

Symbol	Bits	Type	Description	RST
RSVD	23:12	RW	RSVD	0 <sub>D</sub>
PLL_ISOPD	11	RW	Isolation pin to disable the PLL: 0 <sub>B</sub> ... PLL is connected 1 <sub>B</sub> ... PLL is isolated	1 <sub>B</sub>
BG_TMRF_EN	10	RW	Required for temperature sensor readout: 0 <sub>B</sub> ... Disabled 1 <sub>B</sub> ... Enabled	0 <sub>B</sub>
SADC_ISOPD	9	RW	Enable the isolation of all control signals towards the sensor ADC: 0 <sub>B</sub> ... SADC connected 1 <sub>B</sub> ... SADC isolated	1 <sub>B</sub>
MADC_ISOPD	8	RW	Enable the isolation of all control signals towards the MADC:	1 <sub>B</sub>

**BGT60TR13C Registers**

Symbol	Bits	Type	Description	RST
			0 <sub>B</sub> ... MADC connected 1 <sub>B</sub> ... MADC isolated	
BG_EN	7	RW	Enable bandgap in MADC: 0 <sub>B</sub> ... Disabled 1 <sub>B</sub> ... Enabled	0 <sub>B</sub>
RF_ISOPD	6	RW	Enable the isolation of all control signals towards the RF block: 0 <sub>B</sub> ... RF connected 1 <sub>B</sub> ... RF isolated	1 <sub>B</sub>
ABB_ISOPD	5	RW	Enable the isolation of all control signals towards the analog baseband (BB) block: 0 <sub>B</sub> ... BB connected 1 <sub>B</sub> ... BB isolated	1 <sub>B</sub>
CS_EN	4	RW	Enable channel set (CS): 0 <sub>B</sub> ... CS is not used 1 <sub>B</sub> ... CS is used  In case of CSCI or CSCDS this bit is ignored. In the application at least the first channel set should be used by the host (CSC1:CS_EN= 1 <sub>B</sub> ).	0 <sub>B</sub>
REPC	3:0	RW	Repetition factor for Channel set: RC= 2 <sup>REPC</sup> : 0 <sub>D</sub> ... RC= 1 repetition 1 <sub>D</sub> ... RC= 2 repetitions 2 <sub>D</sub> ... RC= 4 repetitions ... 10 <sub>D</sub> ... RC= 1024 repetitions 15 <sub>D</sub> ... RC= 32768 repetitions  In case of CSCI or CSCDS this bit is ignored.	0 <sub>D</sub>

**4.12 CCR0 - Chirp Control Registers 0**

Registers CCRx are used to program the parameters for the modulation sequence. The main FSM will use those parameters to set internal timers and counter to run the expected modulation sequence in standalone mode (no external trigger required except the first one).

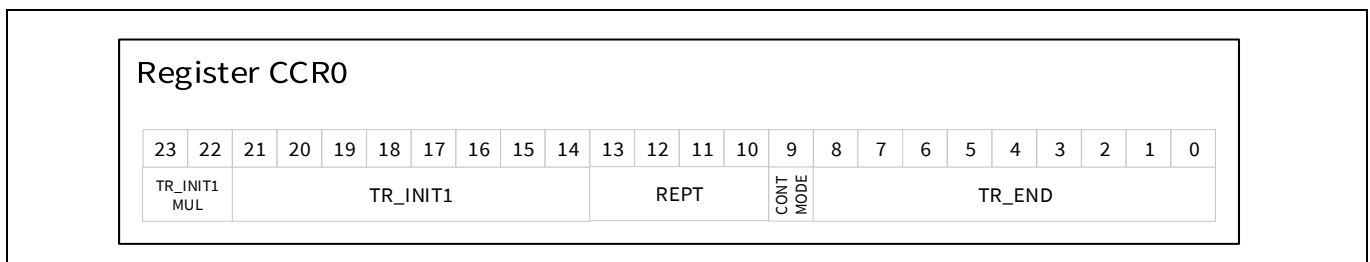

**Figure 29 Chirp Control Register 0**

**Table 33 CCR0: Register Description**

**BGT60TR13C Registers**

Symbol	Bits	Type	Description	RST
TR_INIT1_MUL	23:22	RW	Timer multiplier factor for T_INIT1. Precise timing provided under CCR0:TR_INIT1.	0 <sub>D</sub>
TR_INIT1	21:14	RW	Coefficient to calculate T_INIT1: 0 <sub>D</sub> ... T <sub>SYS_CLK</sub> From 1 <sub>D</sub> to 255 <sub>D</sub> the time delay for T_INIT1 is calculated as follows: T_INIT1 = (TR_INIT1 x 2 <sup>TR_INIT1_MUL</sup> x 8 + TR_INIT1_MUL + 3) x T <sub>SYS_CLK</sub> . See Note below.	0 <sub>D</sub>
REPT	13:10	RW	Repetition factor for shape sets in a frame: RT= 2 <sup>REPT</sup> : 0 <sub>D</sub> ... 1 repetition 1 <sub>D</sub> ... 2 repetitions 2 <sub>D</sub> ... 4 repetitions ... 15 <sub>D</sub> ... 32768 repetitions <b>The host should program as default value 15<sub>D</sub>.</b>	0 <sub>D</sub>
CONT_MODE	9	RW	After last repetition of RT, the CONT_MODE is enabled. 0 <sub>B</sub> ... only in case if deep sleep power mode is enabled (CCR1: PD_MODE= 2 <sub>D</sub> ). The system clock is disabled internally. 1 <sub>B</sub> ... goes to specified power mode (CCR1:PD_MODE) and after T_FED next shapes will run.	0 <sub>B</sub>
TR_END	8:0	RW	Coefficient to calculate T_END. T_END Ramp End Delay defines the waiting time after generation of the ramp. T_END= (TR_END x 8 +5) x T <sub>SYS_CLK</sub> . 0 <sub>D</sub> ... 5* T <sub>SYS_CLK</sub> 511 <sub>D</sub> ... Max. delay	0 <sub>D</sub>

Note:

These values are used for every up and every down-ramp.

**4.13 CCR1 - Chirp Control Registers 1**

Registers CCRx are used to program the parameters for the modulation sequence. The main FSM will use those parameters to set internal timers and counter to run the expected modulation sequence in standalone mode (no external trigger required except the first one).

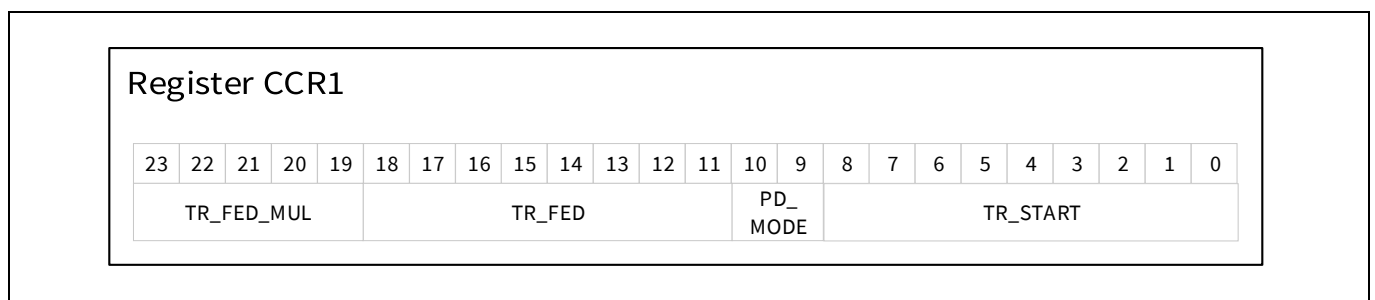

**Figure 30 Chirp Control Register 1**

**BGT60TR13C Registers**

**Table 34 CCR1: Register Description**

Symbol	Bits	Type	Description	RST
TR_FED_MUL	23:19	RW	Timer multiplier factor for frame end delay T_FED. Precise timing provided under CCR1:TR_FED. Note: only values TR_FED_MUL ≤ 10 <sub>D</sub> are verified.	0 <sub>D</sub>
TR_FED	18:11	RW	Coefficient to calculate T_FED: 0 <sub>D</sub> ... T <sub>SYS_CLK</sub> From 1 <sub>D</sub> to 255 <sub>D</sub> the time delay T_FED is calculated as follows: $T\_FED = (TR\_FED \times 2^{TR\_FED\_MUL \times 8 + TR\_FED\_MUL + 3}) \times T_{SYS\_CLK}$ .	0 <sub>D</sub>
PD_MODE	10:9	RW	After last RT repetition the chip enters this power mode for the time T_FED: 0 <sub>D</sub> ... Keep power mode same (CSx, CSCx) 1 <sub>D</sub> ... Idle Mode (CSI + CSCI) 2 <sub>D</sub> ... Deep Sleep Mode (CSDS + CSCDS) 3 <sub>D</sub> ... RSVD	0 <sub>D</sub>
TR_START	8:0	RW	Coefficient to calculate T_START. T_START Ramp Start Delay defines the waiting time before generation of the ramp. $T\_START = (TR\_START \times 8 + 10) \times T_{SYS\_CLK}$ : 0 <sub>D</sub> ... 10 * T <sub>SYS_CLK</sub> 511 <sub>D</sub> ... Max. delay	0 <sub>D</sub>

**4.14 CCR2 - Chirp Control Registers 2**

Registers CCRx are used to program the parameters for the modulation sequence. The main FSM will use those parameters to set internal timers and counter to run the expected modulation sequence in standalone mode (no external trigger required except the first one).

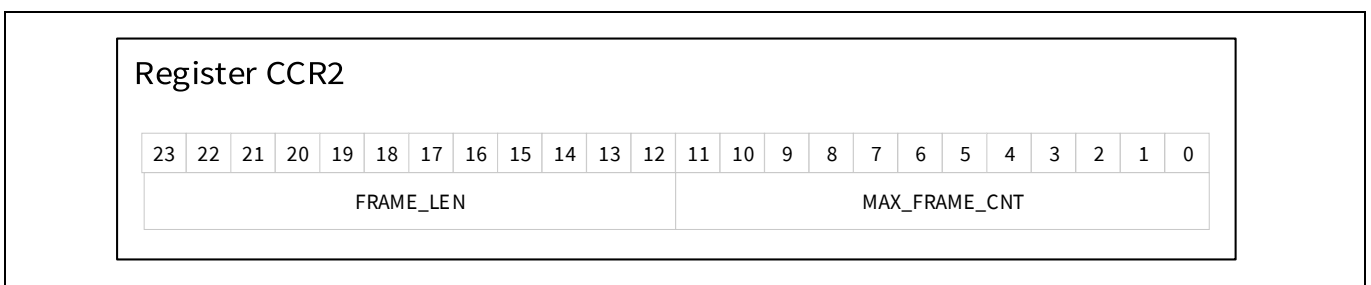

**Figure 31 Chirp Control Register 2**

**Table 35 CCR2: Register Description**

Symbol	Bits	Type	Description	RST
FRAME_LEN	23:12	RW	Frame Length specifies the number of shape groups in a frame. When specified frame length is reached frame counter will be incremented and shape group counter reset: 0 <sub>D</sub> ... 1 shape group 1 <sub>D</sub> ... 2 shape group 4095 <sub>D</sub> ... Max. value (=4096).	0 <sub>D</sub>

**BGT60TR13C Registers**

Symbol	Bits	Type	Description	RST
MAX_FRAME_CNT	11:0	RW	Maximum number of frames to be executed. When MAX_FRAME_CNT is reached, shape generation will stop and the chip will go into deep sleep power mode. The next frame can be triggered only after a reset (eg. FSM_RESET). The frame generation can be stopped any time by the FSM reset (see MAIN: FSM_RESET). 0 <sub>D</sub> ... Endless generation 1 <sub>D</sub> ... 1 frame will be generated 4095 <sub>D</sub> ... Max. number of frames generated (=4095).	0 <sub>D</sub>

**4.15 CCR3 - Chirp Control Registers 3**

Registers CCRx are used to program the parameters for the modulation sequence. The main FSM will use those parameters to set internal timers and counter to run the expected modulation sequence in standalone mode (no external trigger required except the first one).

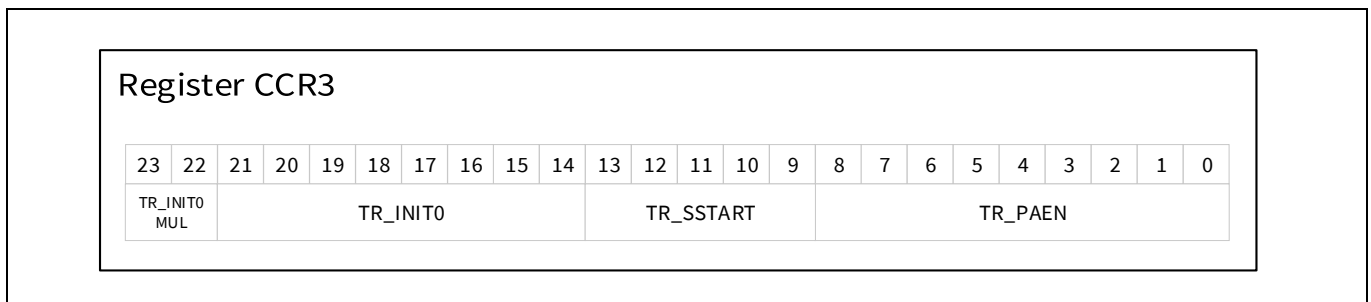

Figure 32 Chirp Control Register 3

Table 36 CCR3: Register Description

Symbol	Bits	Type	Description	RST
TR_INIT0_MUL	23:22	RW	Timer multiplier for delay T_INIT0. Precise timing provided under CCR3:TR_INIT0.	0 <sub>D</sub>
TR_INIT0	21:14	RW	Coefficient to calculate T_INIT0: 0 <sub>D</sub> ... T <sub>sys_clk</sub> From 1 <sub>D</sub> to 255 <sub>D</sub> the time delay for T_INIT0 is calculated as follows: $T\_INIT0 = (TR\_INIT0 \times 2^{TR\_INIT0\_MUL} \times 8 + TR\_INIT0\_MUL + 3) \times T_{sys\_clk}$ . See Note 3.	0 <sub>D</sub>
TR_SSTART	13:9	RW	Coefficient to calculate T_SSTART. T_SSTART Sampling Start Delay Time after PA enable until 1 <sup>st</sup> trigger to MADC. $T\_SSTART = (TR\_SSTART \times 8 + 1) \times T_{sys\_clk}$ : 0 <sub>D</sub> ... T <sub>sys_clk</sub> 31 <sub>D</sub> ... Max. delay	0 <sub>D</sub>
TR_PAEN	8:0	RW	Coefficient to calculate T_PAEN. T_PAEN Delay Time after PLL Start to PA enable. $T\_PAEN = TR\_PAEN \times 8 \times T_{sys\_clk}$ : 0 <sub>D</sub> ... RSVD 1 <sub>D</sub> ... Min. delay	0 <sub>D</sub>

**BGT60TR13C Registers**

Symbol	Bits	Type	Description	RST
			511 <sub>D</sub> ... Max. delay	

Note:

1. One single step is equal to  $8 \times T_{SYS\_CLK}$  system clock cycles (= 100 ns)
2. The delay values are used for every up and every down-ramp
3.  $T\_INIT0$  and  $T\_INIT1$  should be programmed to a minimum value according to the ADC calibration time. See also Table 15 and Table 60.

**4.16 PLLx[0..6] - Chirp Shape Registers**

Registers PLLx, where x can be 1 to 4, are used to program the parameters for the modulation sequence inside the PLL local FSM. The main FSM will control the local PLL FSM to run the expected modulation sequence in standalone mode (no external trigger required except the first one).

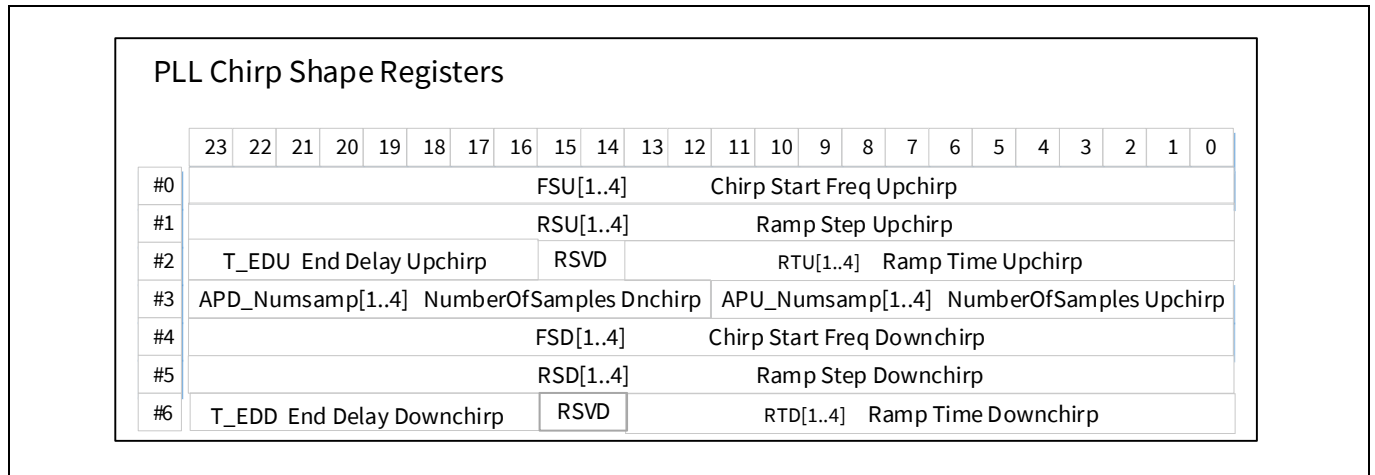

**Figure 33 PLL Chirp Shape Registers 1-6**

**Table 37 PLLx#0 ... PLLx#6 Chirp Shape: Register Description**

Symbol	Bits	Type	Description	RST
FSU[1..4] FSD[1..4]	23:0	RW	Chirp Start Freq Upchirp / Downchirp. SDM start frequency for the ramp generator: FSD = 0 <sub>D</sub> for saw-tooth shape In case FSD=0, RSD=0, and RTD=0, then the fast saw-tooth shape is enabled. In all other cases the triangular shape is enabled.	0 <sub>D</sub>
RSU[1..4] RSD[1..4]	23:0	RW	Ramp Step Upchirp / Downchirp. A ramp step is the RF frequency difference added to the actual frequency during single clock cycle time of $T_{SYS\_CLK} = 12.5$ ns. In case the value is zero the RF frequency will be almost constant during the RTU/RTD time. Bit(23) represents the sign for the ramp: 0 <sub>D</sub> ... Upchirp 1 <sub>D</sub> ... Downchirp	0 <sub>D</sub>

**BGT60TR13C Registers**

Symbol	Bits	Type	Description	RST
TR_EDU[1..4] TR_EDD[1..4]	23:16	RW	Coefficients to calculate T_EDU and T_EDD, respectively. T_EDU and T_EDD are End of Chirp Delay applied after every Upchirp and Downchirp. If TR_EDU/D = 0: T_EDU/D = 2 x T <sub>sys_clk</sub> . If TR_EDU/D > 0: T_EDU/D = (8 x TR_EDU/D + 5) x T <sub>sys_clk</sub> . 255D ... Max. delay	0 <sub>D</sub>
RSVD	15:14		Reserved on register #2 and #6.	0 <sub>D</sub>
RTU[1..4] RTD[1..4]	13:0	RW	Ramp Time Upchirp / Downchirp. RTU/D defines the number of clock cycles for the Upchirp (RTU) or Downchirp (RTD). The actual ramp time is T_RAMP[U D] = [RTU RTD] * 8 x T <sub>sys_clk</sub> : 0 <sub>D</sub> ... Timer disabled. Disabling the timer is useful when doing Downchirp operation with fast down chirp enabled. 1 <sub>D</sub> ... T_RAMP = 100 ns 16383 <sub>D</sub> ... T_RAMP = 2 <sup>14</sup> x 100 ns = 1.6383 ms	0 <sub>D</sub>
APD[1..4] APU[1..4]	23:12 11:0	RW	Number of samples for Upchirp (APU) or Downchirp (APD) for the results of a single ADC: 0 <sub>D</sub> ... No sampling during chirp 1 <sub>D</sub> ... Number of samples = 1 4095 <sub>D</sub> ... Max. number of samples is 4095	0 <sub>D</sub>

Note:

IRQ FIFO interrupt is generated based on FIFO words. One FIFO word of 24 bit captures two ADC samples of 12 bit. For dual and quad ADC operation all samples result in 1 or more FIFO words. In single ADC mode, if an odd number of samples are selected, the FIFO interrupt will be generated after the following (even) sample. For single channel mode an even number of samples is recommended.

**4.17 PLLx[7] – SCR Shape Control Register**

Registers PPLx[7], where x can be 1 to 4, are used to program the parameters for the modulation sequence inside the PLL local FSM. The main FSM will control the local PLL FSM to run the expected modulation sequence in standalone mode (no external trigger required except the first one).

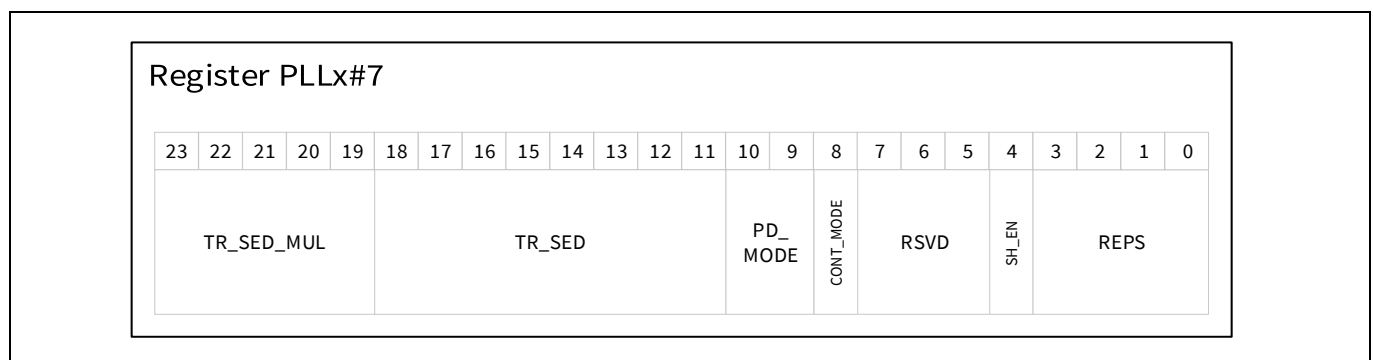

**Figure 34 PLLx#7 SCR shape control register**

**Table 38 PLLx#7 SCR Shape Control: Register Description**



## BGT60TR13C Registers

Symbol	Bits	Type	Description	RST
TR_SED_MUL	23:19	RW	Timer multiplier factor for shape end delay T_SED. Precise timing provided under PLLx#7:TR_SED. Note: only values TR_SED_MUL ≤ 10 <sub>D</sub> are verified.	0 <sub>D</sub>
TR_SED	18:11	RW	Coefficient to calculate T_SED: 0 <sub>D</sub> ... T <sub>sys_clk</sub> From 1 <sub>D</sub> to 255 <sub>D</sub> the time delay T_SED is calculated as follows: $T\_SED = (TR\_SED \times 2^{TR\_SED\_MUL \times 8 + TR\_SED\_MUL + 3}) \times T_{sys\_clk}$	0 <sub>D</sub>
PD_MODE	10:9	RW	After last shape repetition, FSM goes to a specified Power Down Mode (run this mode during T_SED): 0 <sub>D</sub> ... Keep power mode same (CSx, CSCx) 1 <sub>D</sub> ... Idle Mode (CSI + CSCI) 2 <sub>D</sub> ... Deep Sleep Mode (CSDS + CSCDS) 3 <sub>D</sub> ... RSVD	0 <sub>D</sub>
CONT_MODE	8	RW	After last shape repetition REPS, FSM: 0 <sub>B</sub> ... goes to a specified Power Down Mode and stop immediately 1 <sub>B</sub> ... goes to a specified Power Down Mode and after T_SED it runs the next shapes	0 <sub>B</sub>
RSVD	7:5	RW	RSVD	0 <sub>D</sub>
SH_EN	4	RW	Enables the specific shape x (see Note 3): 0 <sub>B</sub> ... shape is not used regardless of shape parameters PLLx[1..7] are programmed with values different from default value. 1 <sub>B</sub> ... shape is used	0 <sub>B</sub>
REPS	3:0	RW	Repetition factor for a single shape x: RSx = 2 <sup>REPSx</sup> : 0 <sub>D</sub> ... RSx = 1 repetition 1 <sub>D</sub> ... RSx = 2 repetitions 2 <sub>D</sub> ... RSx = 4 repetitions ... 15 <sub>D</sub> ... RSx = 32768 repetitions	0 <sub>D</sub>

Note:

1. When chirp shapes are not used FSU/RSU/RTU register fields must be programmed to 0<sub>D</sub> (see also Table 37).
2. A “saw-tooth” chirp can be defined by setting field FSD = 0<sub>D</sub>, and programming the fields for Upchirp (see also Table 37).
3. At least the first shape needs to be enabled (PLL1[7]:SH\_EN = 1<sub>B</sub>)

#### 4.18 PLL DFT0 Register

The setting in this register should be used when the CW mode is enabled (see also 10.2).

BGT60TR13C Registers

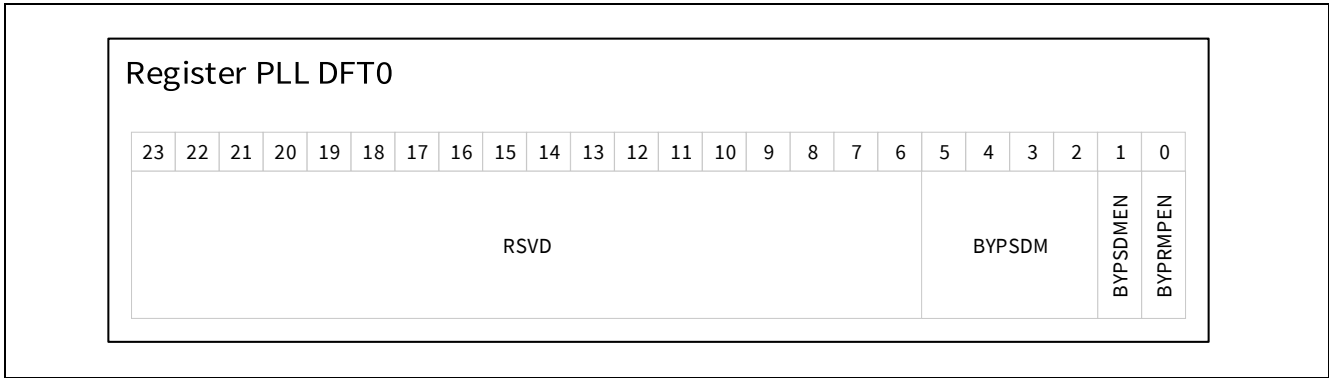

Figure 35 PLL DFT0 register

Table 39 PLL DFT0: Register Description

Symbol	Bits	Type	Description	RST
RSVD	23:6	RW	RSVD	0 <sub>D</sub>
BYPSDM	5:2	RW	SDM output data when SDM is bypassed	0 <sub>D</sub>
BYPSDMEN	1	RW	The PLL core shall overwrite SDM output value with value driven on PDCR2.BYPSDM when this register changes from '0 <sub>B</sub> ' to '1 <sub>B</sub> '. A transition from '1 <sub>B</sub> ' to '0 <sub>B</sub> ' disables this feature and returns the control to SDM: 0 <sub>B</sub> ... SDM module drives the ANA (functional mode) 1 <sub>B</sub> ... BYPSDM(3:0) drives the ANA	0 <sub>B</sub>
BYPRMPEN	0	RW	The PLL core shall overwrite SDM input value with value driven on PDCR1.SDMSTRT when this register changes from '0' to '1'. A transition from '1' to '0' disables this feature and returns the control to ramp generator: 0 <sub>B</sub> ... Ramp generator drives SDM input 1 <sub>B</sub> ... PDCR1.SDMSTRT drives SDM input	0 <sub>B</sub>

4.19 RFT0 – RF Test Register 0

Register contains several bits used to enable dedicated paths for self-test.

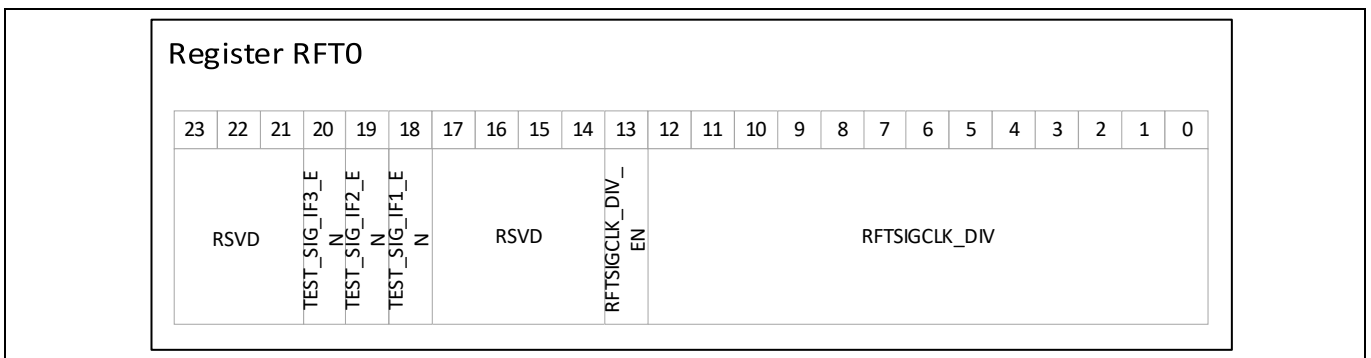

Figure 36 RFT0 RF test register 0

Table 40 RFT0: Register Description

**BGT60TR13C Registers**

Symbol	Bits	Type	Description	RST
RSVD	23:21	RW	RSVD	0 <sub>D</sub>
TEST_SIG_IF3_EN	20	RW	Enable the test signal output for IF channel 3	0 <sub>B</sub>
TEST_SIG_IF2_EN	19	RW	Enable the test signal output for IF channel 2	0 <sub>B</sub>
TEST_SIG_IF1_EN	18	RW	Enable the test signal output for IF channel 1	0 <sub>B</sub>
RSVD	17:14	RW	RSVD	0 <sub>D</sub>
RFTSIGCLK_DIV_EN	13	RW	Enable the RF test tone signal output to the baseband module: 0 <sub>B</sub> ... Disable the divider output 1 <sub>B</sub> ... Enable the divider output	0 <sub>B</sub>
RFTSIGCLK_DIV	12:0	RW	RF test tone signal divider value: $f_{RFTST} = f_{SYS\_CLK} / RFTSIGCLK\_DIV$ . 2 <sub>D</sub> ... Min. divider value    8191 <sub>D</sub> ... Max. divider value	8000 <sub>D</sub>

**4.20 RFT1 - RSVD**

Reserved Register.

**4.21 STAT0 - Status Register 0**

The status register STAT0 provides the actual value of some specific internal states. However, it should be mentioned that for all status registers, STAT0, STAT1, and FSTAT, with the exception of the FIFO status and error flags, updates to each status register field can happen on different timing events relative to FSM states and the field content should be treated independently from one-another. In CW mode the status bits can be read properly after eg. 100 μs.

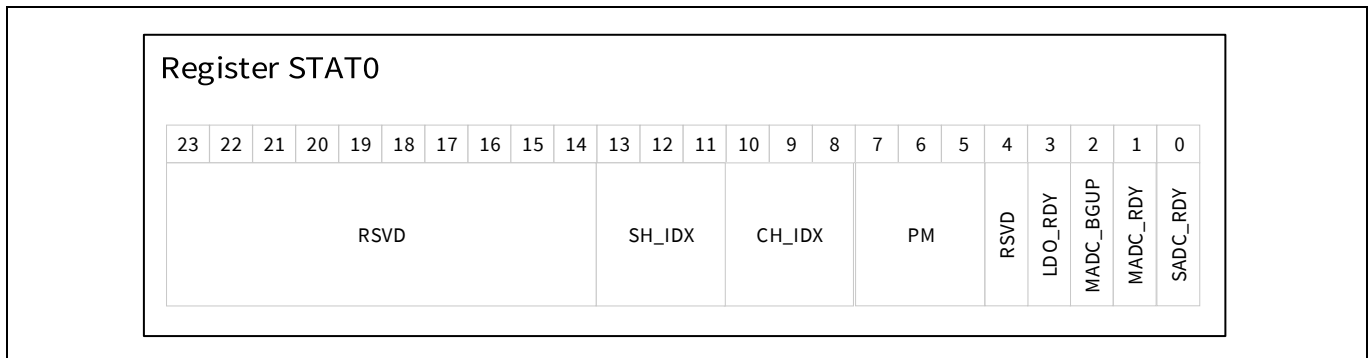

**Figure 37 STAT0: Control FSM Status Register**

**Table 41 STAT0: Register Description**

Symbol	Bits	Type	Description	RST
RSVD	23:14	R	RSVD	0 <sub>D</sub>
SH_IDX	13:11	R	Actual chirp shape enabled by the FSM: 0 <sub>D</sub> ... PLLU1 1 <sub>D</sub> ... PLLD1 2 <sub>D</sub> ... PLLU2 3 <sub>D</sub> ... PLLD2 4 <sub>D</sub> ... PLLU3	0 <sub>D</sub>

## BGT60TR13C Registers

Table 41 STAT0: Register Description

Symbol	Bits	Type	Description	RST
			5 <sub>D</sub> ... PLLD3 6 <sub>D</sub> ... PLLU4 7 <sub>D</sub> ... PLLD4	
CH_IDX	10:8	R	Actual channel set enabled by the FSM: 0 <sub>D</sub> ... CSU1 1 <sub>D</sub> ... CSD1 2 <sub>D</sub> ... CSU2 3 <sub>D</sub> ... CSD2 4 <sub>D</sub> ... CSU3 5 <sub>D</sub> ... CSD3 6 <sub>D</sub> ... CSU4 7 <sub>D</sub> ... CSD4	0 <sub>D</sub>
PM	5:7	R	Power Mode is the current power mode status of FSM: 1 <sub>D</sub> ... Active Mode 2 <sub>D</sub> ... Interchirp Mode 3 <sub>D</sub> ... Idle Mode 5 <sub>D</sub> ... Deep Sleep Mode 0 <sub>D</sub> ,4 <sub>D</sub> ,6 <sub>D</sub> ,7 <sub>D</sub> ... RSVD	5 <sub>D</sub>
RSVD	4	R	RSVD	0 <sub>B</sub>
LDO_RDY	3	R	LDO output level, i.e., VDDC above the threshold: 0 <sub>B</sub> ... LDO output level below threshold 1 <sub>B</sub> ... LDO output level above threshold, ready	0 <sub>B</sub>
MADC_BGUP	2	R	MADC bandgap reference power up status: 0 <sub>B</sub> ... Status down 1 <sub>B</sub> ... Up and running	0 <sub>B</sub>
MADC_RDY	1	R	MADC status: 0 <sub>B</sub> ... Status down 1 <sub>B</sub> ... Up and running	0 <sub>B</sub>
SADC_RDY	0	R	SADC startup / calibration status: 0 <sub>B</sub> ... Status down 1 <sub>B</sub> ... Up and running	0 <sub>B</sub>

## 4.22 SADC\_RESULT Sensor ADC Result Register

The sensor ADC register SADC\_RESULT is used to monitor the SADC as well as to read out the output from the conversion.

BGT60TR13C Registers

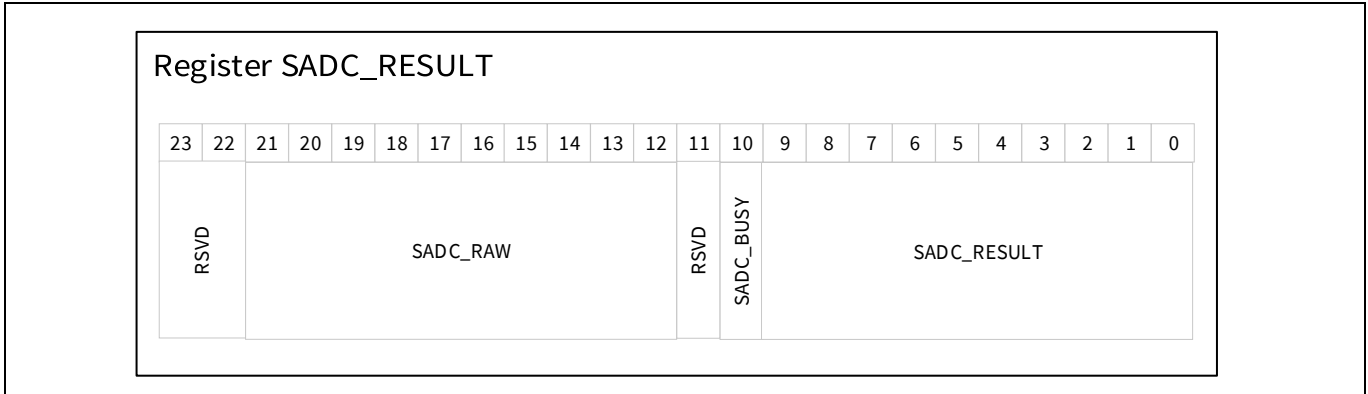

Figure 38 SADC\_RESULT registers

Table 42 SADC: Register Description

Symbol	Bits	Type	Description	RST
RSVD	23:22	R	RSVD	0 <sub>D</sub>
SADC_RAW	21:12	R	SADC Raw data (for test only)	0 <sub>D</sub>
RSVD	11	R	RSVD	0 <sub>B</sub>
SADC_BUSY	10	R	Shows if SADC is busy: 0 <sub>B</sub> ... SADC not busy 1 <sub>B</sub> ... SADC busy	0 <sub>B</sub>
SADC_RESULT	9:0	R	10 bits measurement result. In case just 8 bits are converted, the 8 bits value is left-shifted by two (multiplied by 4). In case 9 bit are converted, the 9 bits result is left-shifted by 1 (multiplied by 2).	0 <sub>B</sub>

4.23 FSTAT - FIFO Status Register

The FIFO status register FSTAT is used to monitor the FIFO. It should be mentioned that for all status registers, STAT0, STAT1, and FSTAT, with the exception of the FIFO status and error flags, updates to each status register field can happen on different timing events relative to FSM states and the field content should be treated independently from one-another. In CW mode the status bits can be read properly after eg. 100 μs.

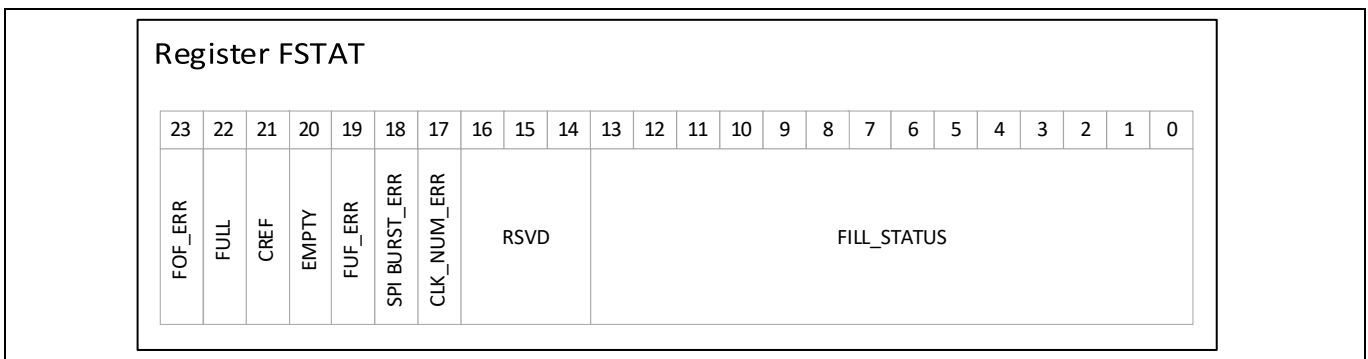

Figure 39 FSTAT Register

Table 43 FSTAT: Register Description

## BGT60TR13C Registers

Symbol	Bits	Type	Description	RST
FOF_ERR	23	R	FIFO overflow error bit shows if more sample data are transferred to the FIFO than FIFO memory locations are available to store the data. The flag will be shown also in GSR0 as a part of FIFO over or underflow error bit FOU_ERR: 0 <sub>B</sub> ... No FIFO overflow 1 <sub>B</sub> ... FIFO had an overflow condition	0 <sub>B</sub>
FULL	22	R	The FULL bit shows if the FIFO has fully filled up: 0 <sub>B</sub> ... FIFO is not full 1 <sub>B</sub> ... FIFO is full	0 <sub>B</sub>
CREP	21	R	0 <sub>B</sub> ... FIFO filling status below CREP 1 <sub>B</sub> ... FIFO filling status is > CREP	0 <sub>B</sub>
EMPTY	20	R	The FIFO empty bit EMPTY signals if the FIFO is empty: 0 <sub>B</sub> ... FIFO stores at least one sample 1 <sub>B</sub> ... FIFO is empty	1 <sub>B</sub>
FUF_ERR	19	R	FIFO under flow error signals if the host was reading more sampling data from the FIFO than available. The flag will be shown also in GSR0 as a part of FIFO over or underflow error bit FOU_ERR: 0 <sub>B</sub> ... No error 1 <sub>B</sub> ... FIFO underflow occurred	0 <sub>B</sub>
SPI BURST_ERR	18	R	In case of burst error this bit is set. Further details in the Note below and in 5.8: 0 <sub>B</sub> ... No error 1 <sub>B</sub> ... Burst error occurred. Bit will be reset after HW or SW reset condition. See also section 5.8.	0 <sub>B</sub>
CLK_NUM_ERR	17	R	Clock number error bit is set when SPI clocks do not fit the expected clock cycles. Further details in the Note below and in 5.8: 0 <sub>B</sub> ... No error 1 <sub>B</sub> ... Burst error occurred. Bit will be reset after HW or SW reset condition. See also section 5.8.	0 <sub>B</sub>
RSVD	16:14	R	Not used	0 <sub>B</sub>
FILL_STATUS	13:0	R	FIFO filling status: 0x0 ... FIFO empty 0x1000 ... FIFO 50% filled 0x2000 ... FIFO full This bit field is for de-bugging only. It should not be evaluated while the MADC sampling and filing up the FIFO. It can be evaluated when the FSM status is held, for example, after an FSM reset or in a specific power mode e.g., Deep Sleep.	0 <sub>B</sub>

## BGT60TR13C Registers

Note:

FOF/FUF will be cleared after these resets:

- FIFO reset
- SW reset
- HW reset

### 4.24 GSR0 - Global Status Register

The global status register GSR0 is related to SPI read/write monitoring.

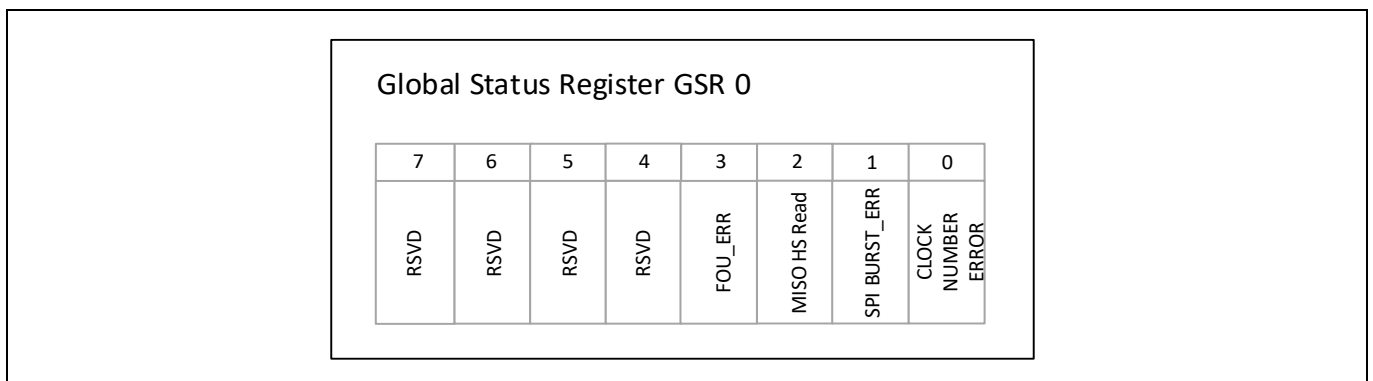

Figure 40 GSR0 Register

Table 44 GSR0: Register Description

Symbol	Bits	Type	Description	RST
RSVD	7	R	Reserved	
RSVD	6	R	Reserved	
RSVD	5	R	Reserved	
RSVD	4	R	Reserved	
FOU_ERR	3	R	Shows if FIFO overflow or underflow condition occurred. The error will be cleared after the following resets: FIFO reset or SW reset or HW reset: 1 <sub>B</sub> ... Error condition occurred 0 <sub>B</sub> ... No error	0 <sub>B</sub>
MISO HS Read	2	R	SPI: MISO high speed mode activated	1 <sub>B</sub>
SPI BURST_ERR	1	R	SPI burst error, defined within the SPI spec (see section 5.8): 0 <sub>B</sub> ... No burst read/write error 1 <sub>B</sub> ... Burst error	0 <sub>B</sub>
CLOCK NUMBER ERROR	0	R	Defined within the SPI Spec: 0 <sub>B</sub> ... No clock number error 1 <sub>B</sub> ... Error condition occurred	0 <sub>B</sub>

Data Organization and SPI Interface

5 Data Organization and SPI Interface

5.1 Data Header

The main FSM is capable of generating a data header to be attached to the actual radar raw data. The structure of the header is shown in Figure 41 and in Table 45. The data header can be disabled by controlling the bit SFCTL:PREFIX\_EN (see section 4.8).

A sync-word is sent at the beginning of each acquisition to make the radar raw-data from each shape unique. This can be useful in case of broken communication with the application processor or in case of errors. Supposing the FIFO will generate a “FIFO overflow flag” the sync-word 0x000000 can be evaluated by the host controller and used to resync with the BGT60TR13C and discard the data received before this sync word (if header or sync-word not used then the controller should reset the FIFO, discarding the actual FIFO data). On “FIFO underflow flag”, the received data bits from the host are 111111111111<sub>B</sub>.

Following, the header includes also the frame counter and shape group counter, as well as the actual APU/APD value (see section 4.16) and temperature value.

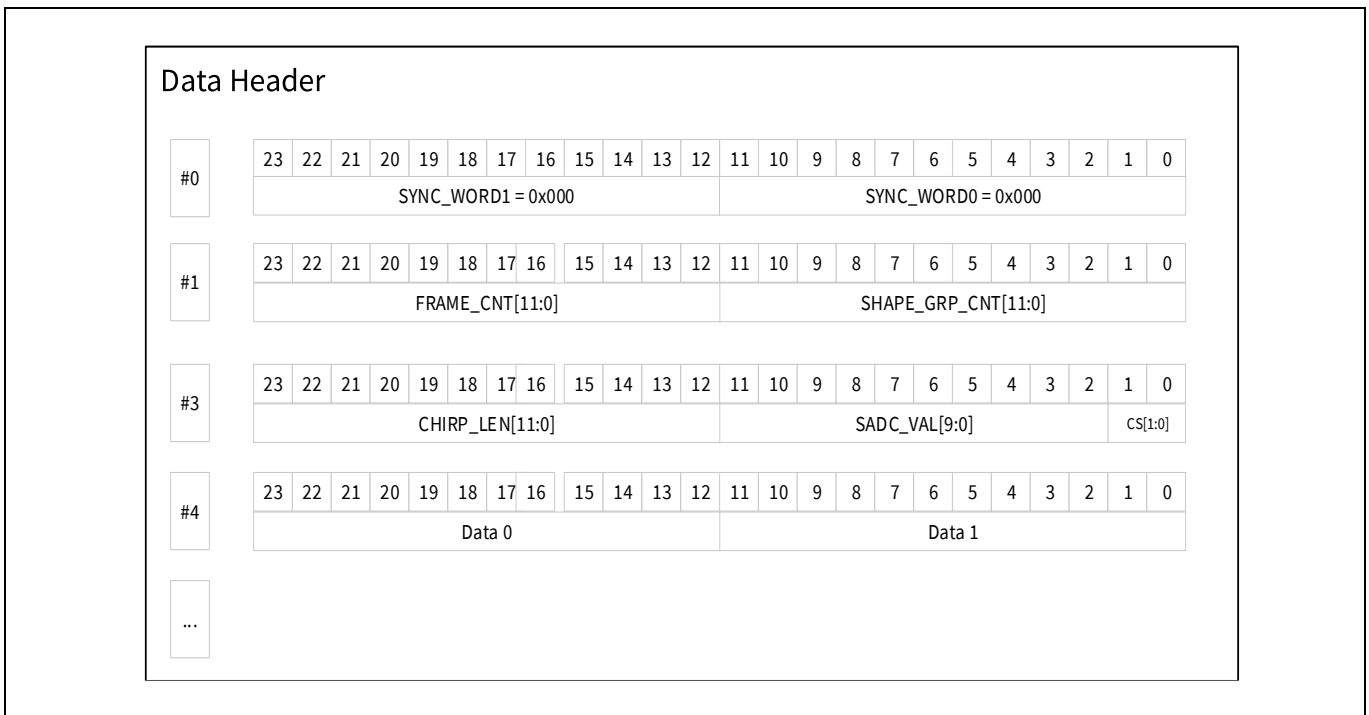

Figure 41 Data header



## Data Organization and SPI Interface

**Table 45 Data Header Description**

Symbol	Reg	Bits	Description	RST
SYNC_WORD1	#0	23:12	The sync-word can be used to identify the start of a new chirp. In case the MADC will output also a sequence of 0x000000, to make the sync-word unique, the data from the MADC will be automatically changed to 0x001 before transferring it to the FIFO.	0 <sub>D</sub>
SYNC_WORD0	#0	11:0	See SYNC_WORD1.	0 <sub>D</sub>
FRAME_CNT	#1	23:12	Same as STAT1:FRAME_CNT (see section 4.5). Note: FRAME_CNT info should not be used by the host when endless mode is enabled (please check CCR2:MAX_FRAME_CNT).	0 <sub>D</sub>
SHAPE_GRP_CNT	#1	11:0	Same as STAT1:SHAPE_GRP_CNT (see section 4.5).	0 <sub>D</sub>
CHIRP_LEN	#2	23:12	Number of MADC samples inside the chirp (APU/APD value of related chirp).	0 <sub>D</sub>
SADC_VAL	#2	11:2	10 bits of sensor ADC output data (eg. temperature).	0 <sub>D</sub>
CS	#2	1:0	Indicates the channel shape number to which the following sampling data belongs to.	
Data 0	#3	23:12	MSB data (see section 5.2).	
Data 1	#3	11:0	LSB data (see section 5.2).	

### 5.2 FIFO and Dataflow

The memory in the BGT60TR13C is based on a FIFO. The FIFO consists of a circular shift register organized in 8192 words of 24 bits each. Three dataflow modes from MADC to the FIFO are supported by the FSM (see Figure 42):

- Mode 1: Only one ADC active (can be any ADC from 1 to 3)
  - Data from 1<sup>st</sup> sample, 12 bits, are temporarily stored in a buffer
  - When the 2<sup>nd</sup> sample, 12 bits, are available, both, 1<sup>st</sup> and 2<sup>nd</sup>, 24 bits, are stored into one data word
- Mode 2: Two ADCs active (can be any ADC from 1 to 3)
  - Data from active ADCs, 12+12 bits, are occupying one data word in the FIFO
- Mode 3: Three ADCs active
  - Data from first two channels are stored into a data word while data from third channel is buffered. On the consecutive trigger the buffered data and the one from first channel are stored in a data word while the data of the second channel is buffered. On the next trigger the buffered data plus the data from the third channel are stored in a third data word, etc.

**Data Organization and SPI Interface**

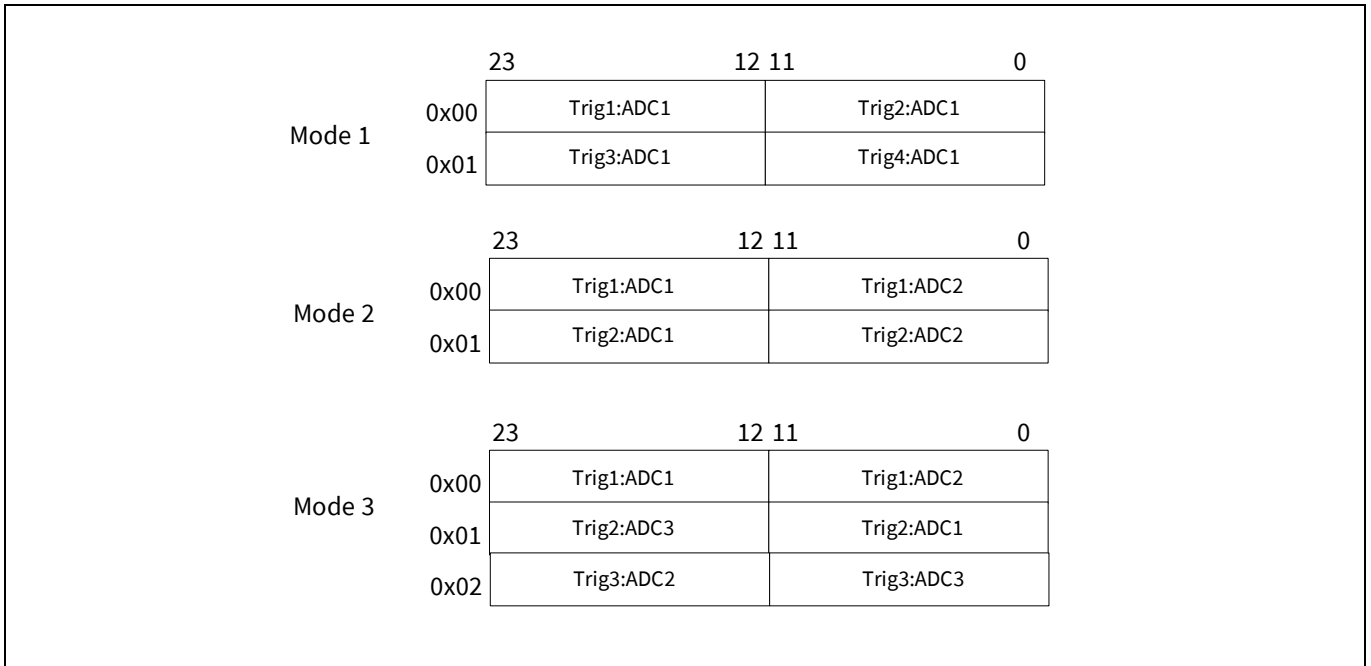

**Figure 42 FIFO organization**

Readout from the FIFO is done from the SPI block. Due to max frequency of SPI clock, 50 MHz, the readout rate from the FIFO is:

- $50 \text{ MHz} / \text{SPI Mode} / 24 \text{ bit} = 480 \text{ ns} = 40 \text{ cycles}$  (in the 80 MHz domain)

Readout from the FIFO should be executed from the host controller using memory address with correct data length. Data length can be derived from the data header or based on the “sync-word”.

*Note:*

*An illegal write to memory address space will lead to lost FIFO data!*

**5.3 SPI – Serial Peripheral Interface Module**

The SPI is the communication interface between the host and the BGT60TR13C. It enables the host to read from, or write to (program) the registers as well as reading from the FIFO.

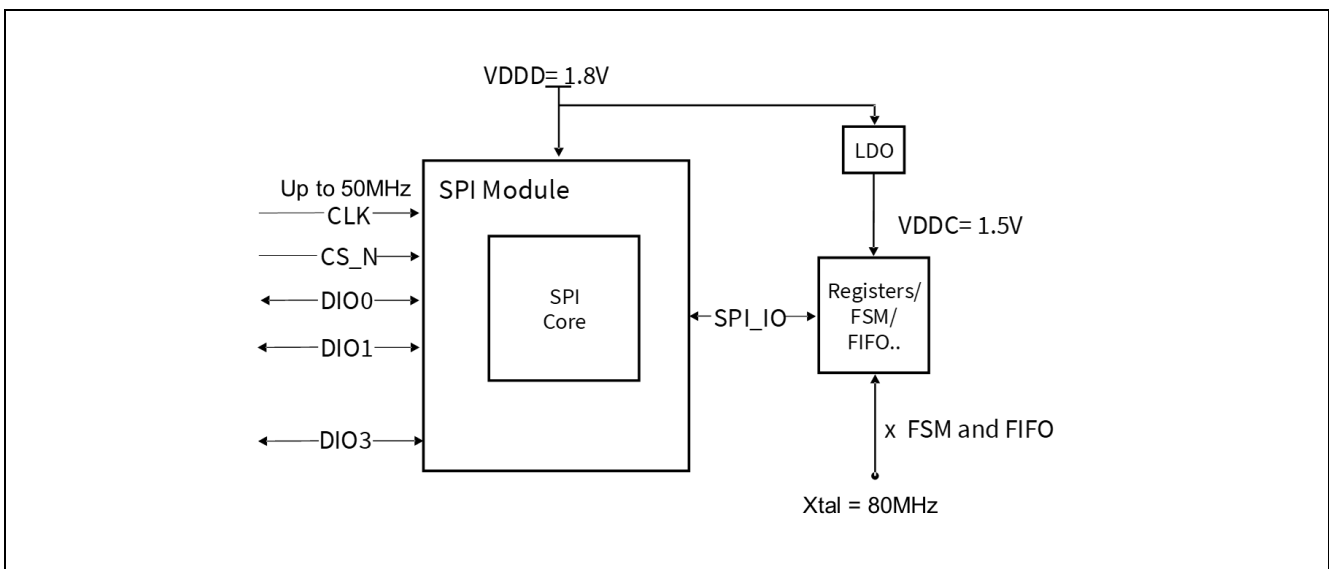

**Figure 43 SPI module**

## Data Organization and SPI Interface

BGT60TR13C device features four I/O pins for SPI communication and one for chip reset. DIO[x] pins are pulled up to logic high inside the pad.

- CS\_N to be connected to SS of the SPI master
- CLK to be connected to CLK of the SPI master
- DIO0, DI to be connected to MOSI of the SPI master
- DIO1, DO to be connected to MISO of the SPI master
- DIO2 not available on BGT60TR13C
- DIO3 to be connected to reset

**Table 46 SPI Pins**

Pin Name	Standard SPI Mode Function	Remarks
CS_N	CS_N	Chip select
CLK	CLK	SPI clock
DIO0	DI	HiZ, bidirectional
DIO1	DO	HiZ, bidirectional
DIO2	N.A.	Not available on BGT60TR13C
DIO3	RESET	HiZ, bidirectional

The SPI interface can be clocked up to 50 MHz. To meet the timing requirements for higher SPI clock frequencies (e.g., > 25 MHz) the BGT60TR13C device offers an additional high-speed mode (SFCTL:MISO\_HS\_RD) which increase the timing budget on SPI master side by sending out data via DO with the rising edge instead of the falling edge of the CLK.

### 5.3.1 Standard SPI Timing

The timing diagram for normal SPI mode (SFCTL:MISO\_HS\_RD =0) is presented in Figure 44. A SPI transfer is started with a falling edge of chip select signal CS\_N generated by the SPI master. At the same time, the SPI master shall drive the level of the data input signal DI (master output, slave input) according to the first bit. Also, with the falling edge of the chip select signal CS\_N the SPI slave applies the level of the data output signal DO (master input, slave output) according to the first bit which shall be transferred to the SPI master, the level becomes stable after the period  $t(ds)$ . The SPI master has to wait for the time  $t(L)$  before the clock signal CLK can be generated.

With the rising edge of CLK the SPI slave captures the level of DI. The SPI master must keep the DI level stable for  $t(mos)$  before and for  $t(moh)$  after the rising edge of CLK to ensure valid setup and hold time of the SPI slave. With the falling edge of CLK the SPI master shall set the level of DI according to the next bit the master wants to send.

The SPI master is supposed to read the level of DO with the rising edge of CLK. The SPI slave keeps the DO level stable for  $t(mis)$  before and for  $t(mih)$  after the rising edge of CLK. With the falling edge of CLK the SPI slave drives the level of DO according to the next bit, DO becomes stable after  $t(mih)$ .

After the last bit has been transferred and CLK has gone to low level, the SPI master must set CS\_N to high level to stop the transfer. The master must take care that the period between the last rising edge of CLK and the rising edge of CS\_N is not shorter than  $t(T)$ . Within the period  $t(dh)$  after the rising edge of CS\_N the SPI slave drives DO to high impedance state again.

Data Organization and SPI Interface

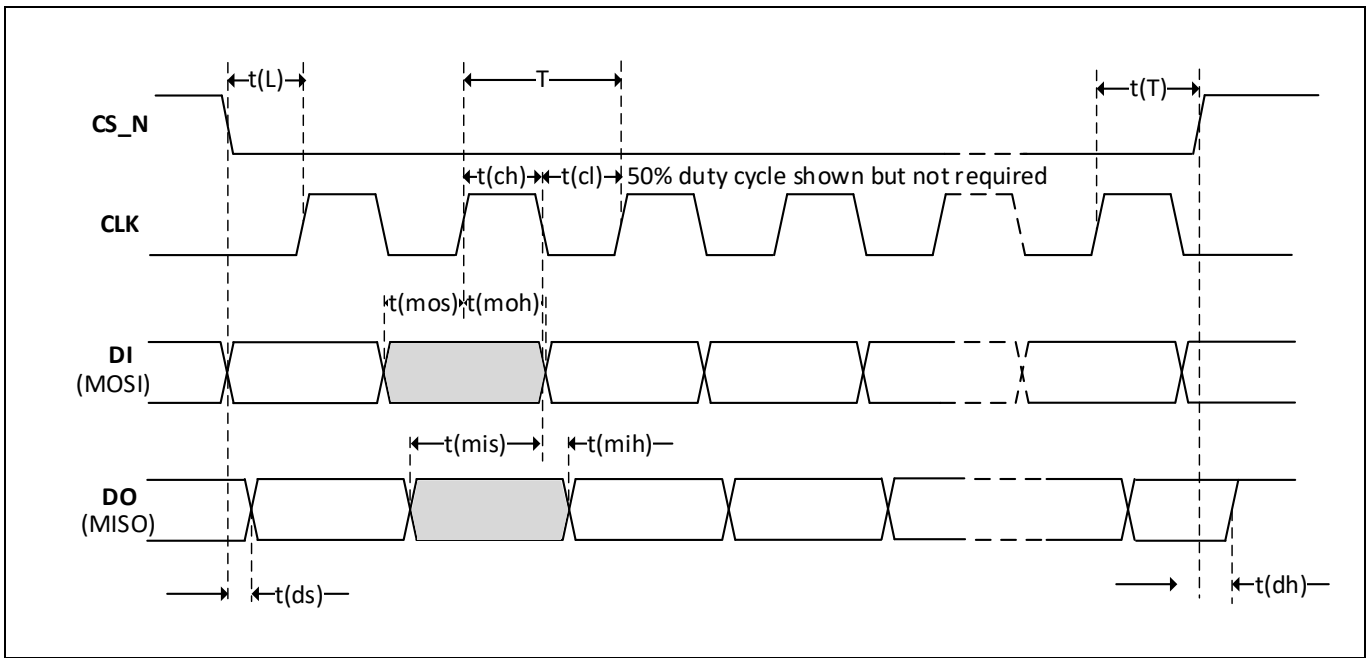

Figure 44 SPI interface timing diagram for SFCTL:MISO\_HS\_RD = 0<sub>b</sub>

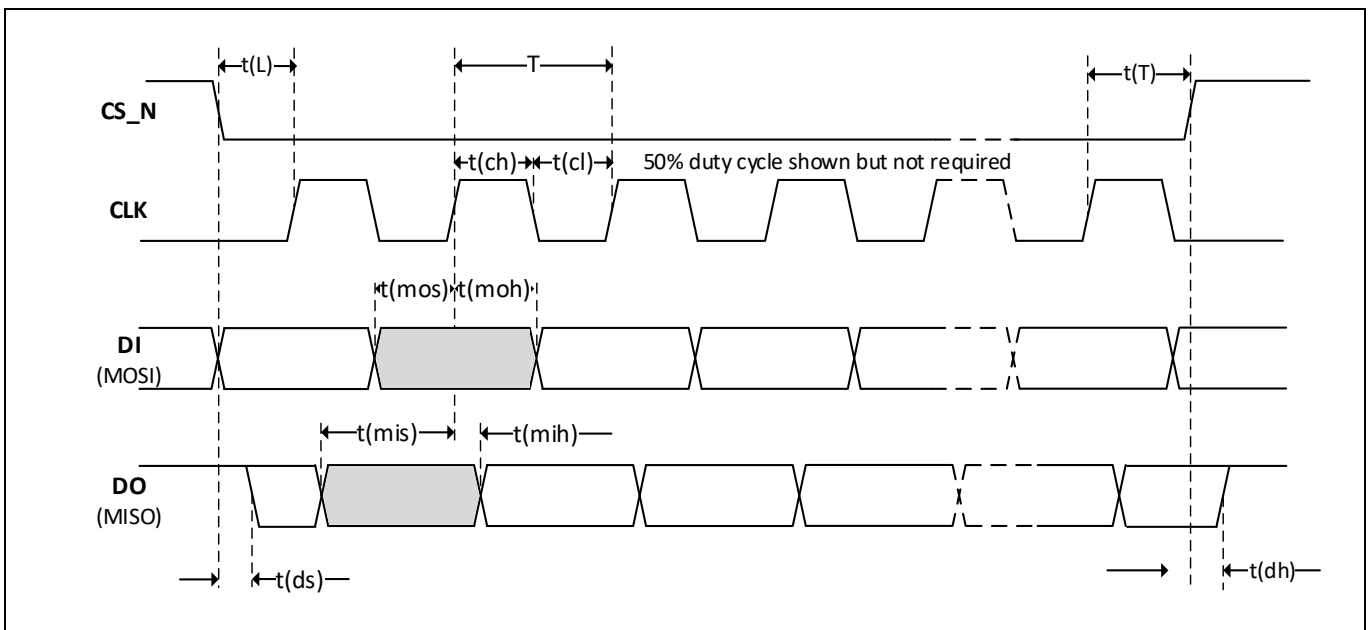

Figure 45 SPI interface timing diagram for SFCTL:MISO\_HS\_RD = 1<sub>b</sub>

BGT60TR13C can operate at SPI clock frequencies up to 50MHz, but the maximum achievable SPI clock frequency is limited by DI related setup and hold times of SPI master and SPI slave. If for example the SPI master requires a longer MISO setup time than  $t(mis)$ , the SPI clock speed in normal SPI mode must be reduced. Alternatively, BGT60TR13C can be switched to SPI high-speed mode by setting SFCTL:MISO\_HS\_RD = 1<sub>b</sub>.

The timing diagram for high speed SPI mode is presented in Figure 45. In this mode the SPI master is still supposed to capture the level of DO with the rising edge of CLK. The SPI slave keeps the level of DO stable for  $t(mis)$  before the rising edge of CLK. The SPI slave keeps the level of DO stable for  $t(mih)$  after the rising edge of CLK, and then sets the level of DO according to the next bit which is send out.

## Data Organization and SPI Interface

**Table 47 SPI Timing Requirements, VDDD = 1.71 to 1.89 V, Tb = -20 to +70 °C**

Spec	Symbol	Unit	Value			Condition
			Min	Typ	Max	
Parameter			Min	Typ	Max	
SPI clock period: 50MHz, with 1% clock jitter	T	ns	20			
Clock high	t(ch)	ns	9.0			
Clock low	t(cl)	ns	9.0			
Master output setup	t(mos)	ns	5.0			
Master output hold	t(moh)	ns	5.0			
Master input setup	t(mis)	ns	5.0			T=20ns (see Note 2)
Master input hold	t(mih)	ns	1.0			
Lead time before the first working clock edge occurs	t(L)	ns	9.0			
Tailing time after the last working clock edge	t(T)	ns	1			
Data setup time after the DO goes in low impedance state	t(ds)	ns			5	Guaranteed by design
Data hold time before the DO goes in hi impedance state.	t(dh)	ns			5	Guaranteed by design

Note:

1. If SFCTL:MISO\_HS\_RD is not set properly then data read on MISO may not be correct.
2.  $t(mis)$  is specified for a maximum SPI clock frequency of 50 MHz. This results in a maximum delay (time output valid) of  $T-t(mis) = 15\text{ ns}$  between falling edge of CLK (for MISO\_HS\_RD=0) and DO level becoming valid. For MISO\_HS\_RD=1 it's the rising edge of CLK. The timing is guaranteed for worst case condition: VDDD = 1.71 V, Tb = +70 °C, output load of Cload = 50 pF.

### 5.3.2 Logic Levels

The digital inputs and outputs are fully CMOS compatible (reported in Table 48). All IO input / output timings are based on 50% voltage reference levels (see Figure 46). I/O interfaces are shown in Figure 49, input pins, and Figure 50, output pins, which include internal pull-ups.

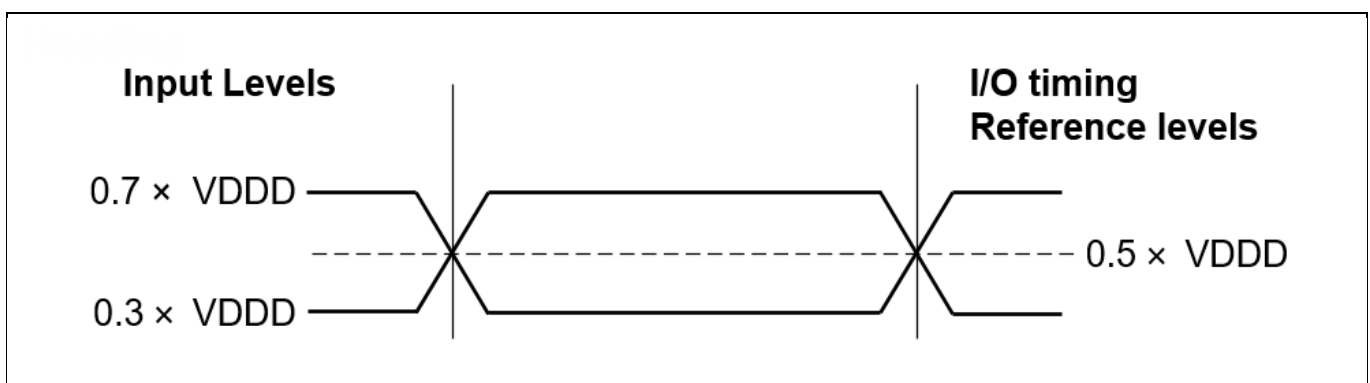
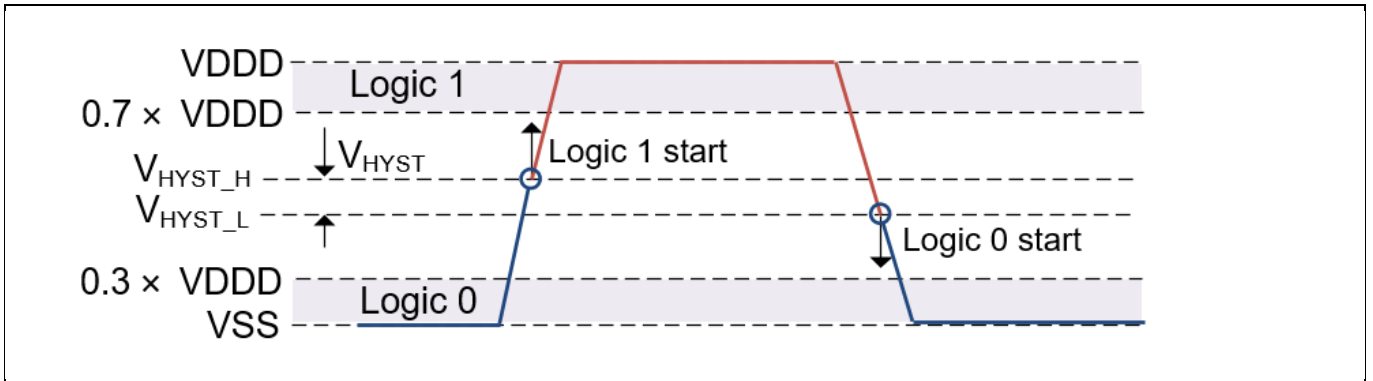

**Figure 46 AC timing input/output reference levels**

The input logic hysteresis prevents input buffers from oscillation. The minimum hysteresis range  $V_{HYST}$  is in between the lower ( $0.3 \times V_{DDD}$ ) and upper logic level ( $0.7 \times V_{DDD}$ ) boundaries (see Figure 47). Above  $0.7 \times V_{DDD}$

**Data Organization and SPI Interface**

the input signal is a logical ‘1’ while below  $0.3 \times V_{DD}$  it is a logical ‘0’ regardless of hysteresis. Due to temperature drifts and device variation the hysteresis range  $V_{HYST}$  can be up to  $0.7 \times V_{DD}$  or down to  $0.3 \times V_{DD}$  but typically around  $0.5 \times V_{DD}$ . Parameters reported in Table 48 and Table 49.



**Figure 47 Logic input levels and hysteresis**

The digital output pads have a fixed output pad strength that gives a specific slew-rate for rising signals,  $dV_{TR}$ , and falling signals,  $dV_{TF}$  (see Figure 48). Minimum slew rates were simulated considering a total capacitive load of 15pF. Results reported in Table 48 and Table 49.

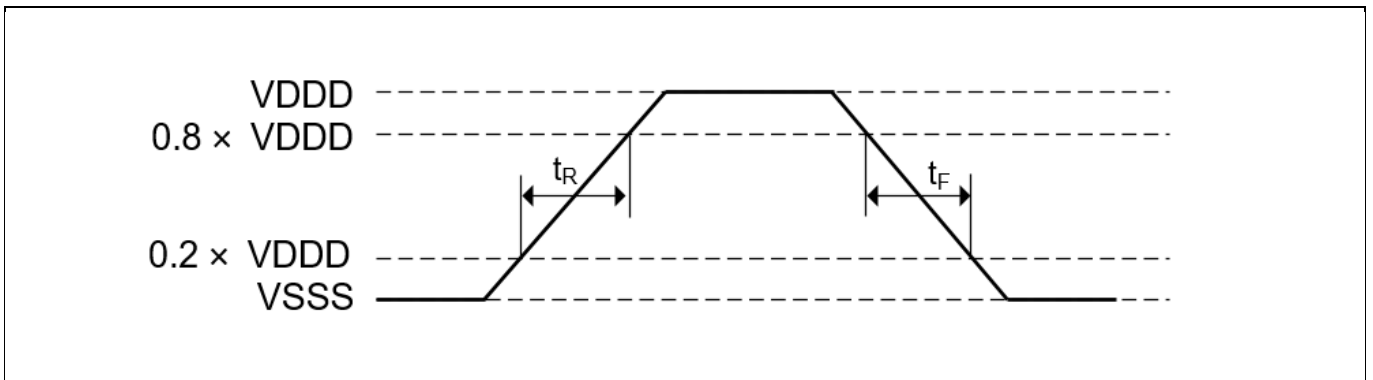

**Figure 48 Rise/Fall Time, Slew Rate specified between  $0.2 \times V_{DD}$  and  $0.8 \times V_{DD}$**

## Data Organization and SPI Interface

**Table 48 Logical Levels for input pins** VDDD = 1.71 to 1.89 V, Tb = -20 to +70 °C, ambient temperature not below -40 °C; all voltages with respect to VSSD digital ground, positive current flowing into pin (unless otherwise specified)

Spec	Symbol	Unit	Value			Condition
			Min	Typ	Max	
Parameter			Min	Typ	Max	
LOW level	$V_{IN(L)}$	V	0		$0.3 \times V_{DDD}$	
HIGH level	$V_{IN(H)}$	V	$0.7 \times V_{DDD}$		VDDD	
Input current ( $0V < V_{IN} < V_{DDD}$ )	$I_{IN}$	$\mu A$	-150		150	
Input capacitance CLK/CS_N	$C_{IN}$	pF		2.0		
Input capacitance DI/DIO3	$C_{IN}$	pF		3.15		
Minimum hysteresis voltage range between $0.3 \times V_{DDD}$ and $0.7 \times V_{DDD}$	$V_{HYST}$	V	0.175			$V_{HYST\_H} - V_{HYST\_L}$
Upper hysteresis signal level	$V_{HYST\_H}$	V		$0.5 \times V_{DDD} + \frac{V_{HYST}}{2}$	$0.7 \times V_{DDD}$	
Lower hysteresis signal level	$V_{HYST\_L}$	V	$0.3 \times V_{DDD}$	$0.5 \times V_{DDD} - \frac{V_{HYST}}{2}$		

## Data Organization and SPI Interface

**Table 49 Logic Levels for output pins** VDDD = 1.71 to 1.89 V, Tb = -20 to +70 °C, ambient temperature not below -40 °C; all voltages with respect to VSSD digital ground, positive current flowing into pin (unless otherwise specified)

Spec	Symbol	Unit	Value			Condition
			Min	Typ	Max	
Parameter			Min	Typ	Max	
LOW level	$V_{OUT(L)}$	V	0		$0.3 \times V_{DDD}$	
HIGH level	$V_{OUT(H)}$	V	$0.7 \times V_{DDD}$		VDDD	
Output current (LOW)	$I_{OUT(L)}$	mA	-5			
Output current (HIGH)	$I_{OUT(H)}$	mA			5	
Allowed load capacitance to provide maximum signal frequency on DO	$C_{LOAD}$	pF			15	
Minimum hysteresis voltage range between $0.3 \times V_{DDD}$ and $0.7 \times V_{DDD}$	$V_{HYST}$	V	0.175			$V_{HYST\_H} - V_{HYST\_L}$
Upper hysteresis signal level	$V_{HYST\_H}$	V		$0.5 \times V_{DDD} + \frac{V_{HYST}}{2}$	$0.7 \times V_{DDD}$	
Lower hysteresis signal level	$V_{HYST\_L}$	V	$0.3 \times V_{DDD}$	$0.5 \times V_{DDD} - \frac{V_{HYST}}{2}$		
Output pad slew rate for rising wave form	$dV_{TR}$	V/ns	0.32			$0.2 \times V_{DDD}$ to $0.8 \times V_{DDD}$
Output pad slew rate for falling wave form	$dV_{TF}$	V/ns	0.33			$0.2 \times V_{DDD}$ to $0.8 \times V_{DDD}$



Data Organization and SPI Interface

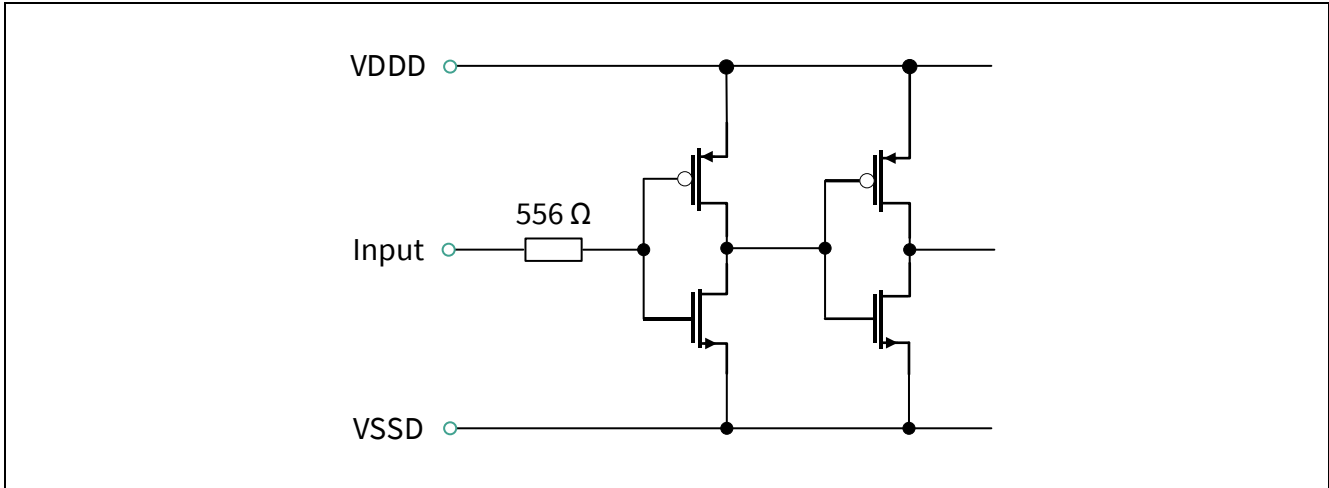

Figure 49 Interface for input pins CLK, CS\_N, DI, DIO3

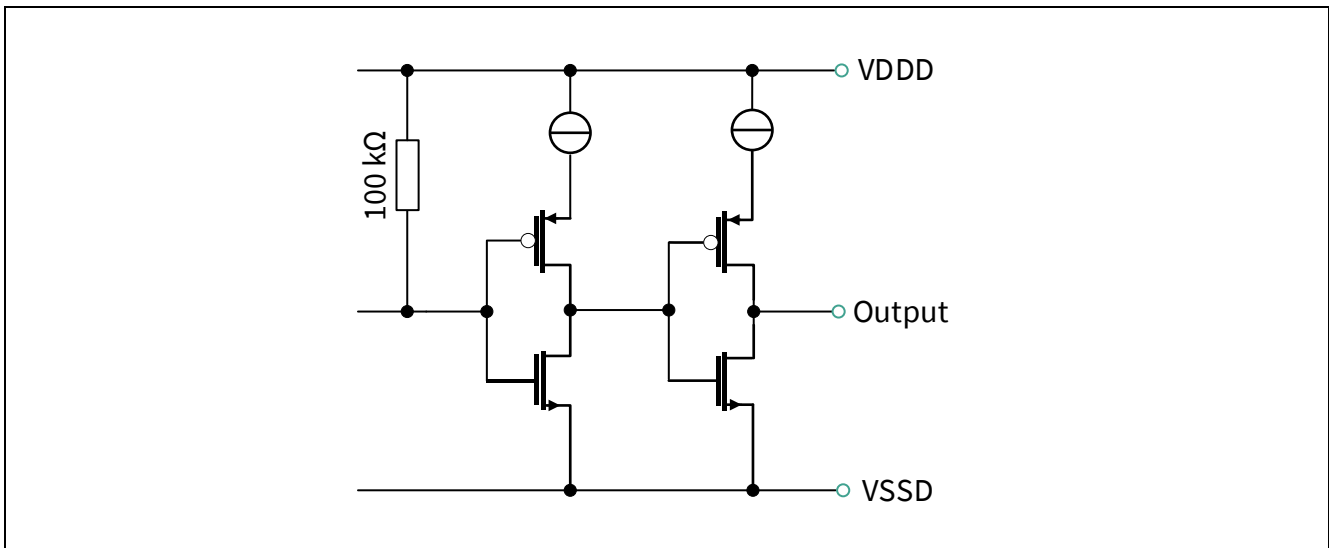

Figure 50 Interface for output pins IRQ, DO, DIO3

5.4 Overshoot and Undershoot Waveform Definition

During operation, the applied signals and supply levels should not exceed absolute maximum DC levels specified in datasheet. Digital signals can have positive or negative overshoots due to inductive and/or capacitive loads. The following Table 50 reports the allowed overshoot timings and signal levels for all logic signals.

Table 50 Overshoot and Undershoot Signal Levels

Spec	Symbol	Unit	Value			Condition
			Min	Typ	Max	
Maximum absolute overshoot voltage level	Vos	V			VDDD + 0.5 V	see Note:
Maximum absolute undershoot voltage level	Vus	V			VSS - 0.5 V	see Note:

Note:

## Data Organization and SPI Interface

Maximum pad current not exceeding  $\pm 5$  mA (see also Table 49). No slew rate limitation existing on digital signals for overshoots / undershoots.

### 5.5 IBIS Model

A BGT60TR13C IBIS Model is available under NDA upon request. It is based on timing simulations. In order to better reflect the real timing behavior, different pad models for input/output signals are used and summarized in Table 51. The driver strength for all pads are fix (PRG0=0).

**Table 51** IBIS Pad Types and Models (see Ibis model)

Pin	Ibis PAD Model
CSN	IN: MODEL_654_7345_110
CLK	IN: MODEL_654_7345_110
DIO0 / DI	IN: MODEL_8138_4982_52 OUT: MODEL_8138_4982_59
DIO1 / DO	IN: MODEL_8138_4982_52 OUT: MODEL_8138_4982_59
DIO2	Not available on BGT60TR13C
DIO3 / Reset	IN: MODEL_8138_4982_52 OUT: MODEL_8138_4982_59
IRQ	OUT: MODEL_8138_4982_55

### 5.6 SPI Functionality

Each word transferred over the SPI bus has a length of 1 command byte + 3 data Bytes. The communication is done bitwise. First the address is transferred with MSB first. The address is followed by the R/W-bit and then followed by the data which is sent MSB first, too. At the same time, while command byte is received, a freely from system level configurative global status register (8 bits, GSR0) is serial shifted out on DO (MSB first). On the following 24 clock cycles the selected register content is shifted out on DO, MSB first.

Depending on sent R/W-bit there are two different operation modes available, the write mode and the read mode. Every write mode is a read mode too.

#### Write-Mode

After the start condition the desired address is sent. The address is 7 bits long followed by a bit that is a data direction bit (read/write). A one indicates a write operation (see Figure 51).

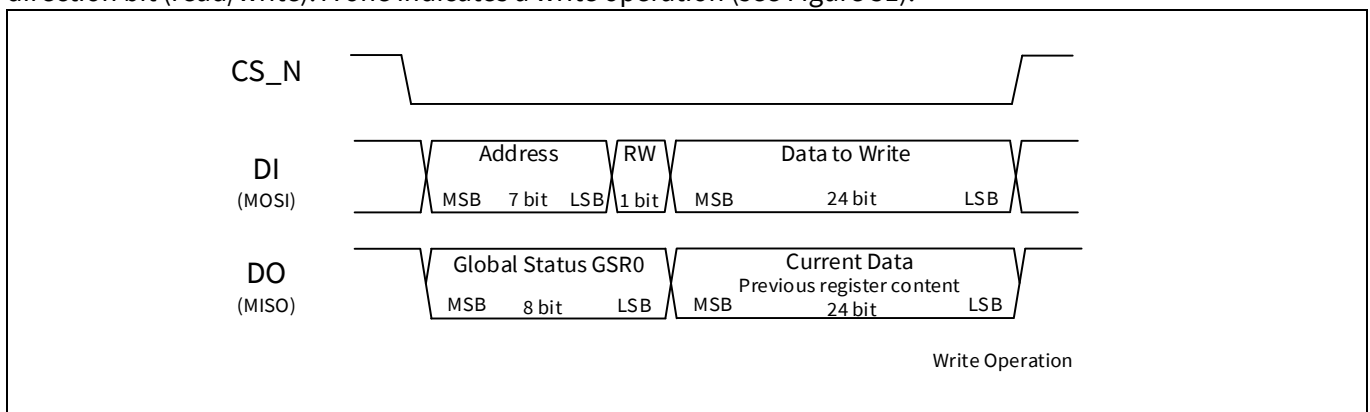

**Figure 51** SPI timing write mode

## Data Organization and SPI Interface

### Read-Mode

After the start condition, the desired address is sent like in the write operation. A zero of the R/W-bit indicates a read access. The data on DI after the command byte may contain any value. The DO behavior is the same as in write mode.

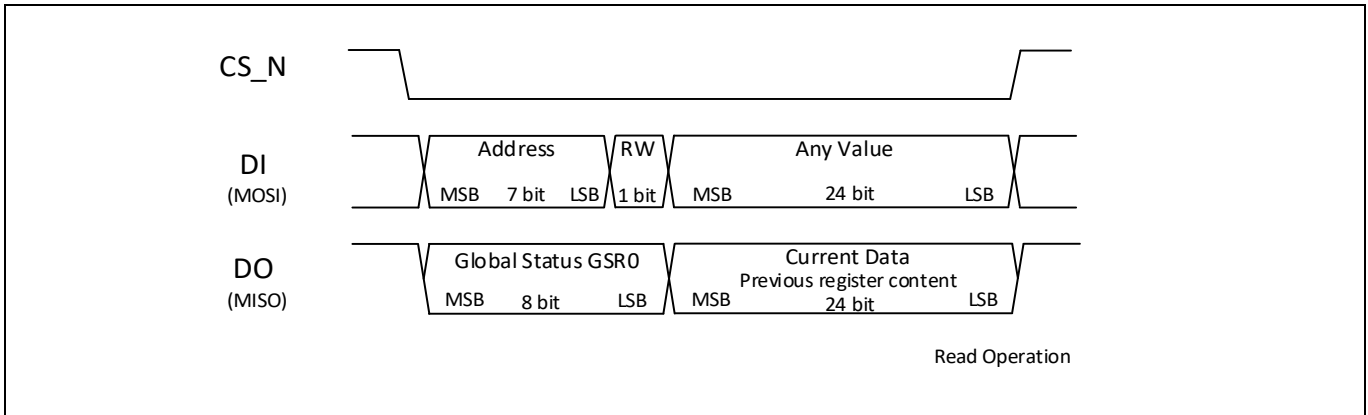

Figure 52 SPI timing read mode

## 5.7 SPI Burst Mode

The burst mode can be used to read or write out several registers or some data from the FIFO instead of reading just single registers or data. The burst mode command is sent by the host. The burst mode command consists of several bit fields and is shown in Figure 53.

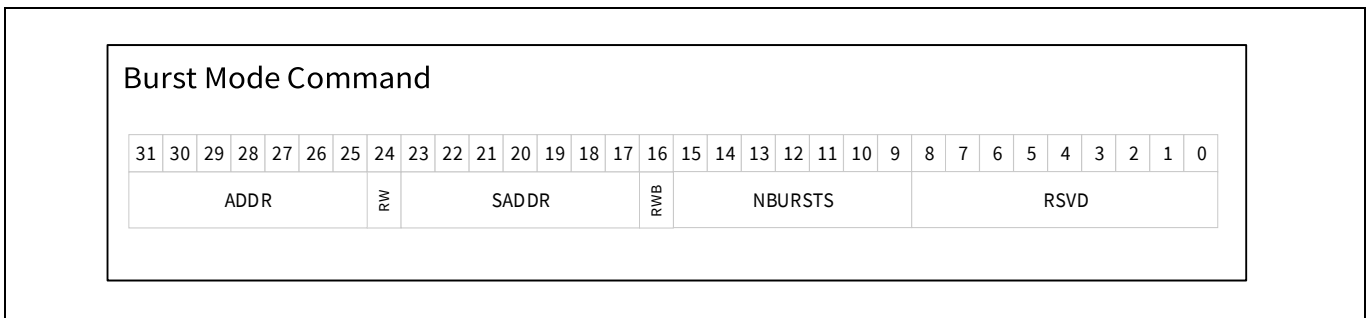

Figure 53 Burst mode command

The following Table 52 shows a detailed description on the burst mode command bit fields.

Table 52 Burst Mode Command Bit Field Description

Bit field	Bit	Description	RST
ADDR	31:25	To enter the burst mode the following address is used: 0x7F ... request the burst read/write.	
RW	24	Read/Write register access: Fixed to 1 <sub>B</sub> ... write to address 0x7F	
SADDR	23:17	Starting address where the burst starts processing: < 0x60 Register access == 0x60 FIFO access > 0x60 Reserved - Address is incremented automatically inside a burst.	
RWB	16	Burst read or write: 0 <sub>B</sub> ... Perform a read burst	

## Data Organization and SPI Interface

Bit field	Bit	Description	RST
		1 <sub>B</sub> ... Perform a write burst, (writes to FIFO not supported)	
NBURSTS	15:9	Number of processed data blocks: 0x00... “unbounded” burst accesses 0x01 to 0x7E ... number of words to transfer	

Note:

A single data block is 24 bits width for both, the sampling memory and the registers.

### Burst Mode Operation

After the start condition the 32 bits burst mode command is sent from the SPI master on DI. At the same time, the status register GSR0 (four 1<sub>B</sub> bits + four status bits) followed by 24 padding bits set to 0<sub>B</sub> is shifted out on DO. After the command sequence is done, the register/FIFO data is shifted out to the SPI master on DO. In burst write mode, the register data to be written is shifted in from the SPI master (application processor e.g.).

### Burst Mode Read Sequence:

In the read sequence, the SPI master reads from the device.

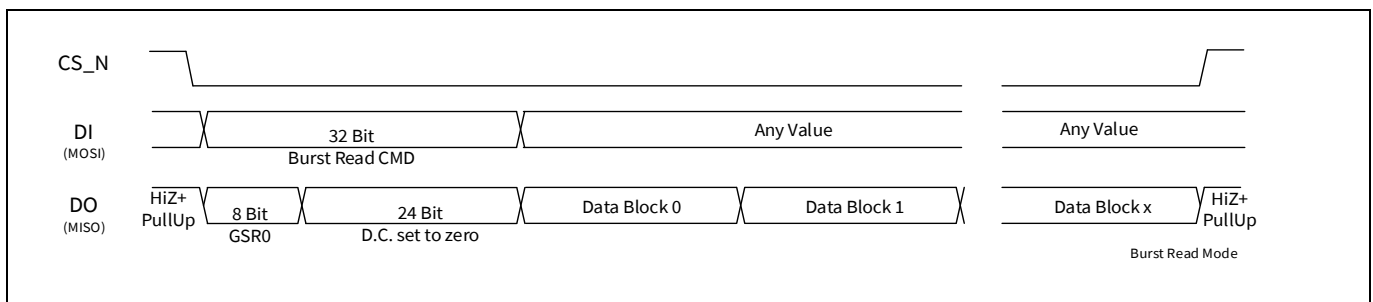

Figure 54 Burst mode read sequence

### Burst Mode Write Sequence:

In the burst write mode, the SPI master writes to the device.

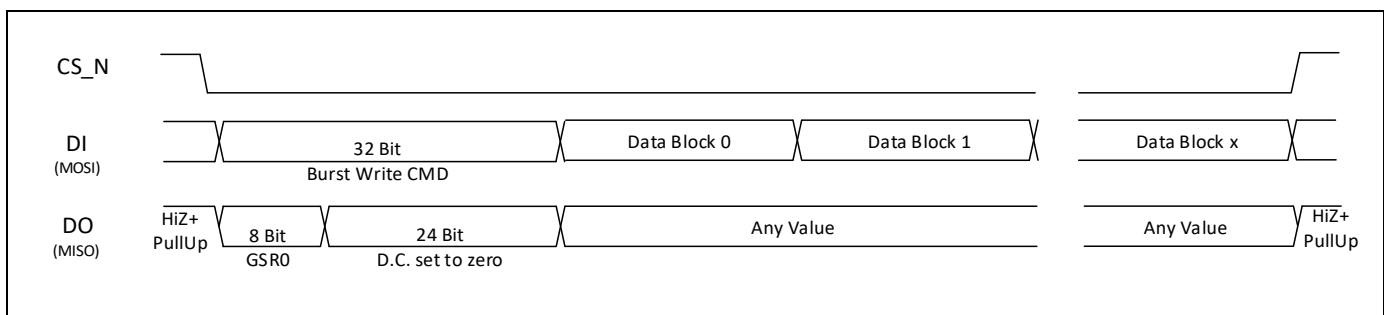

Figure 55 Burst mode write sequence

### Sampling Data Arrangements in Data Blocks

The data from the FIFO are streamed out during the burst read request, starting from the FIFO address zero. The 1<sup>st</sup> ADC is the ADC channel with the lowest channel number. As far as the sampling memory is organized in 24 bits

## Data Organization and SPI Interface

and up to three ADC channels are selectable through the ADC channel selection bits (CSx:BBCH\_SEL, see section 4.10) the data blocks are arranged as follows.

In case a single ADC is selected, the data structure is shown in Figure 56.

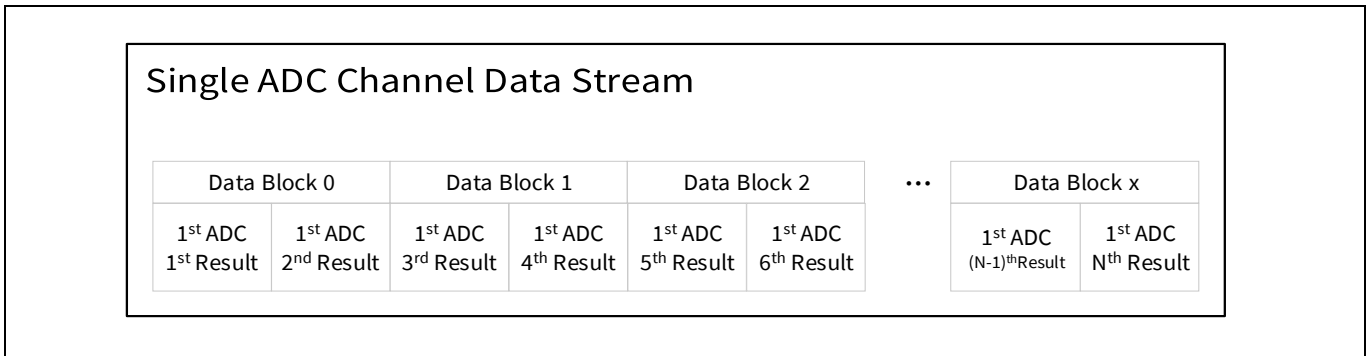

Figure 56 Single ADC channel selected

In case two ADCs are selected, the data structure is shown in Figure 57.

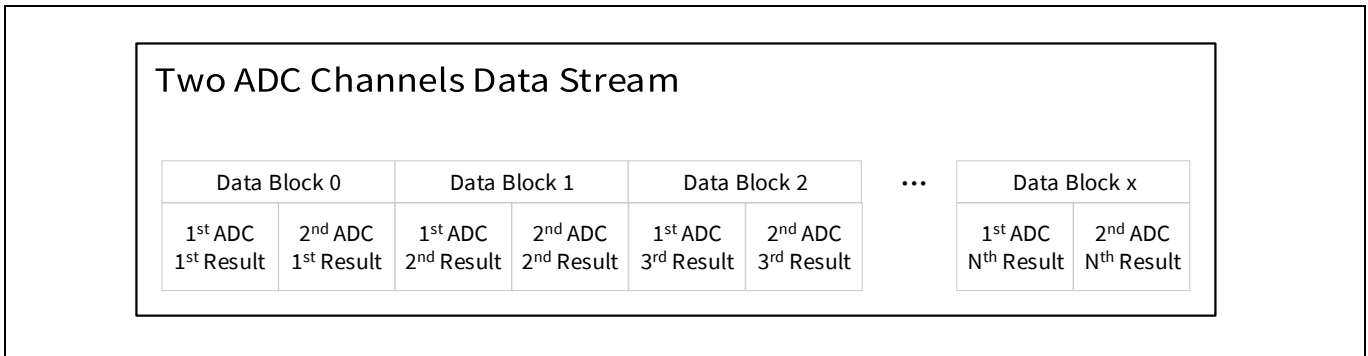

Figure 57 Two ADC channels selected

In case three ADCs are selected, the data structure is shown in Figure 58.

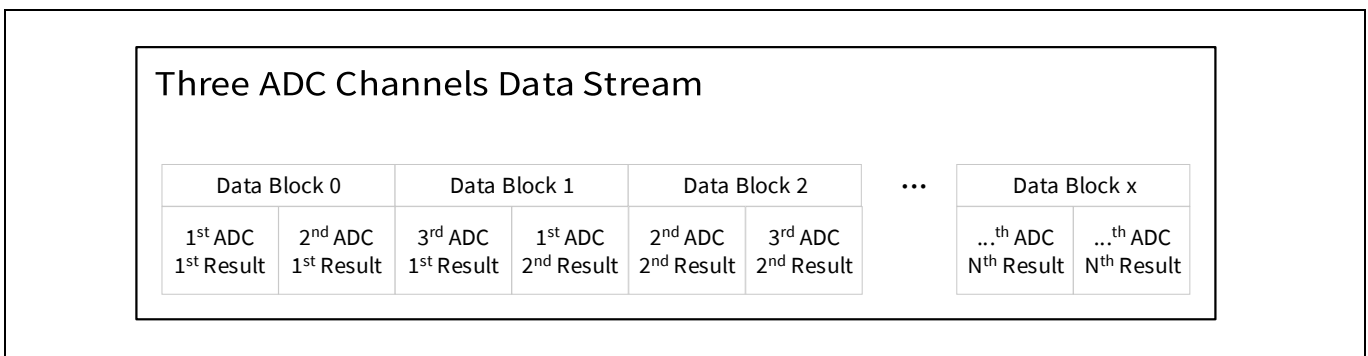

Figure 58 Three ADC channels selected

### Example: Burst Mode Read Sampling Memory Sequence

The following burst mode command is sent from the host to initialize the burst mode to read from the FIFO an undefined number of sampling data:

BMCMD\_RS = (ADDR = 0x7F, RW = 0x01, SADDR = 0x60, RWB = 0x0, NBURSTS = 0)

### REMARK:

## Data Organization and SPI Interface

For each burst read request to the sampling memory, the sampling-memory address pointer is reset to the initial value. So that memory can be read out from the beginning until the application processor stops burst reading.

### Example: Burst Mode Read Registers Sequence

The following burst mode command is sent from the host to initialize the burst mode to read out 10 registers starting from register address 3:

```
BMCMD_RR10 = (ADDR = 0x7F, RW = 0x01, SADDR = 0x3, RWB = 0x0, NBURSTS = 10)
```

## 5.8 SPI Error Detection

SPI BURST\_ERR and CLK\_NUM\_ERR (see also Table 43) will be cleared after these resets:

- SW reset
- HW reset

SPI BURST\_ERR and CLK\_NUM\_ERR are reported in the global status bits of the next SPI transaction and latched as sticky bits in the FSTAT register.

In order to understand if the captured sample data are corrupted, the host can evaluate the bit field CLK\_NUM\_ERR and SPI BURST\_ERR as reported in Table 53.

**Table 53 SPI BURST\_ERR and CLK\_NUM\_ERR Definitions**

Length Range	Transaction	SPI BURST_ERR	CLK_NUM_ERR	Behavior on read/write
0	Null command	0 <sub>B</sub>	0 <sub>B</sub>	Ignored
1-31	Short length error in single	0 <sub>B</sub>	1 <sub>B</sub>	Command ignored
>32	Long length error in single	0 <sub>B</sub>	1 <sub>B</sub>	Extra bits ignored
1-31	Short length error in SPI burst header	0 <sub>B</sub>	1 <sub>B</sub>	Command ignored
<24xN	Missing whole data word in bounded burst	1 <sub>B</sub>	0 <sub>B</sub>	Available data words used
>24xN	Extra whole data word in bounded burst	1 <sub>B</sub>	0	Extra data word(s) ignored
%24>0	Misaligned bit-count for bounded burst	1 <sub>B</sub>	1 <sub>B</sub>	Extra bits ignored
%24>0	Misaligned bit-count for infinite burst	0 <sub>B</sub>	1 <sub>B</sub>	Partial data word may be discarded

Note:

- Ignored write transaction means that no register (or memory) content is affected by the partial write command, or incomplete data word.
- Ignored read transaction means that the returned data is invalid, and for the FIFO no words are removed by the partial read command, or incomplete data word.
- Discarded read transaction means that the data is already read from the FIFO but only partially transferred; subsequent read pops next word from FIFO.

## Data Organization and SPI Interface

- Data from the FIFO may be discarded after a length error in the infinite burst (NBURST=0) occurs. The FIFO read has to happen, since at that stage the data is required to be shifted out, but if not all bits are shifted out the FIFO is already read and the partial data word may be discarded.

### 5.9 Hardware Reset Sequence

The chip should not be in reset state after any reset condition (SW, HW, FIFO, and FSM- reset) especially when no external clock OSC\_CLK is applied (see Table 2). For a proper device reset a special reset sequence is required:

While CS\_N is '1<sub>B</sub>' DIO3 must perform a 1<sub>B</sub> → 0<sub>B</sub> → 1<sub>B</sub> transition

The behavior is presented in Figure 59 with:

T\_CS\_BRES = 100 ns

T\_RES = 100 ns

T\_CS\_ARES = 100 ns

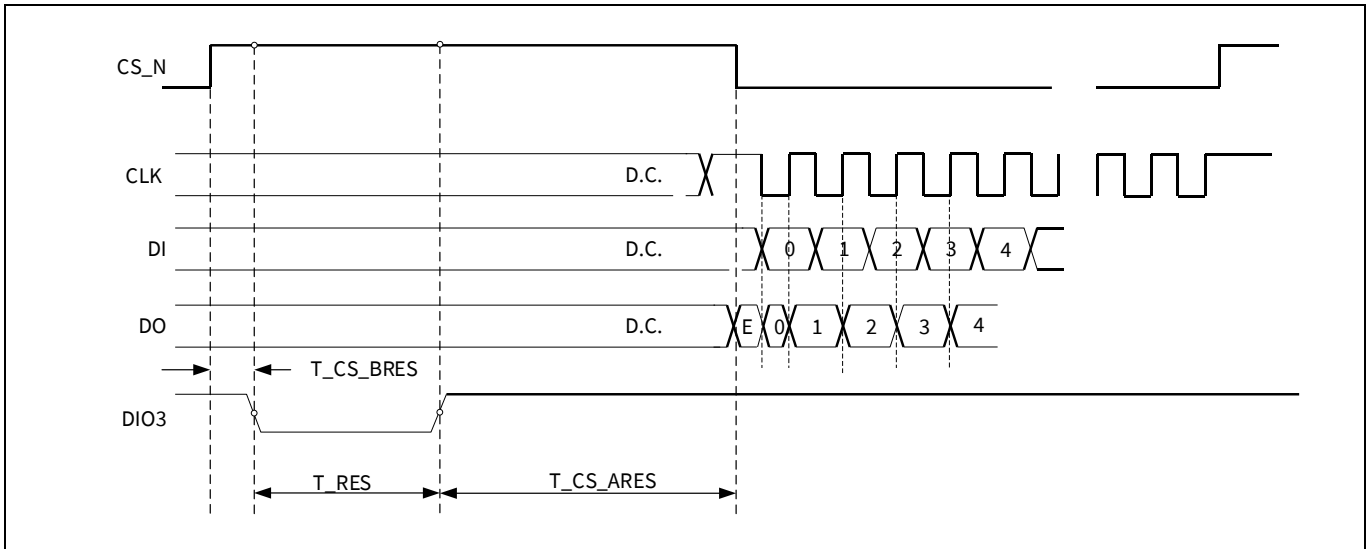

Figure 59 Hardware reset Sequence

### 5.10 Software Triggered Resets

Besides the hard reset, three reset sequences are supported and can be triggered in the ISO register (see also 4.2). They are defined according to the following hierarchy:

Soft reset → FIFO reset → FSM reset

\* **Software Reset**

- Resets all registers to default state
- Resets all internal counters (e.g. shape, frame)
- Perform FIFO reset
- Performs FSM reset
- A delay of 100 ns after the SW\_RESET is needed before the next SPI command is sent

\* **FIFO Reset**

**Data Organization and SPI Interface**

- Reset the read and write pointers of the FIFO
- Array content will not be reset, but cannot be read out
- FIFO empty is signaled, filling status = 0
- Resets register FSTAT
- Performs an implicit FSM reset

**\* FSM Reset**

- Resets FSM to deep sleep mode
- Resets FSM internal counters for channel/shape set and timers
- Resets STAT0 and STAT1 register
- Reset PLL ramp start signal
- Reset PA\_ON
- Terminates frame (shape and frame counters incremented although maybe not complete)



PLL Domain Functional Specification

6 PLL Domain Functional Specification

The PLL is designed to generate high performance frequency chirps in the range of 58 GHz to 63.5 GHz. The modulation is performed inside the PLL bandwidth (in-band-modulation) with an analog charge pump based fractional-N RF-PLL architecture. It furthermore features a shape generator with high flexibility to allow different ramp shapes and duration times. The loop requires a low noise reference clock with a nominal frequency of 80 MHz.

6.1 PLL Interfaces and Clock Distribution:

Figure 60 shows the interfaces to the PLL and the distribution of the 80 MHz reference clock.

6.2 Reference Clock Distribution

The external 80 MHz reference clock signal is provided via a short, low jitter path directly to the input of the PLL analog part. From there the clock is distributed to the reference clock buffer of the PLL and also via another path to the STS, which is the defined interface between the PLL analog and the digital part. These paths are independent from each other since the clock provided through the STS to the output of the PLL macro (“osc\_clk2dig”) serves as the clock for the main FSM. It must be available even when the PLL is put into power down. Therefore, the usage of internally generated supplies of the PLL is avoided. The main FSM clock can be gated via a dedicated register bit called PACR1:OSCCLKEN (see section 4.6) which quiets the clock path already at its beginning.

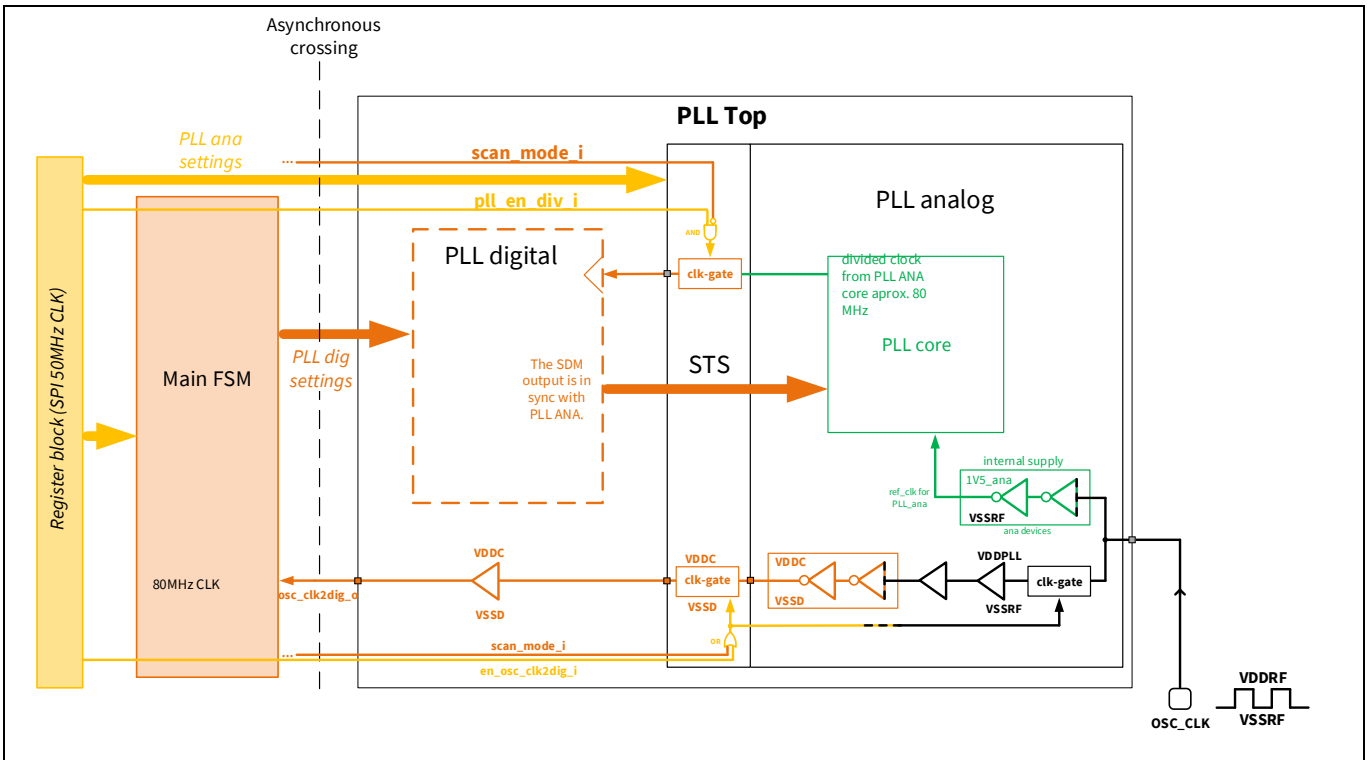

Figure 60 PLL and 80 MHz clock interface to the main FSM

## PLL Domain Functional Specification

### 6.2.1 Interfaces to the PLL

Most static settings and control signals dedicated to the analog part of the PLL are treated as asynchronous signals and are passed from the register bank to the STS of the PLL. This applies to digital signals that are not timing critical. Ramp generation parameters provided from the main FSM to the digital part of the PLL are registered inside the PLL digital. The start signal of the ramp also acts as a synchronization signal of the ramp parameters. This is required since the PLL digital runs on the divided clock of the PLL which ensures a known and synchronous timing relation between the sigma-delta bit stream and the analog part of the PLL that realizes the ramping behavior. The divided clock is only available if the PLL macro and the VCO are activated. Other control signals from PLL digital to the analog part are kept asynchronous. In order to close the PLL loop the analog part of the PLL core has interfaces to the RF-macro where the VCO and a part of the divider chain are located.

### 6.3 PLL Parameters and Specification

Table 54 summarizes the target parameters of the PLL-based frequency generator.

**Table 54 PLL Specifications, VDDPLL = 1.71 to 1.89 V, VDDLDF = 2.5 to 3.63 V, T<sub>b</sub> = -20 to +70 °C**

Spec	Symbol	Unit	Value			Condition/Note
			Min	Typ	Max	
Parameter			Min	Typ	Max	
<b>Reference Clock</b>						
Reference Frequency	f <sub>ref</sub>	MHz	75	80	85	f <sub>ref</sub> = f <sub>SYS_CLK</sub> See 2.2 78 MHz not allowed
Rise and Fall Time of Reference Clock	t <sub>rs,fs,clk</sub>	ns			2	1.8 V CMOS clock
<b>PLL Chirp Parameters</b>						
Output Frequency Range	f <sub>RF</sub>	GHz	58.0		63.5	Range depends on the VDDLDF value
Continuous FM-Chirp Bandwidth	BW	GHz	0		5.5	PLL tuning range
VDDLDF Range	VDDLDF	V	2.5		3.63	5.5 GHz modulation BW requires at least VDDLDF= 3.3V
Chirp slope	Slope	MHz/μs			400	
Frequency Ramp Linearity Error	Error	%			1	For 2 GHz BW minimum See 6.3.1, Figure 12, Table 15
Frequency Ramp Settling Time (fast chirp feature active)	t <sub>PLL,settle</sub>	μs		5		See 6.3.2, section 3.3.5
PLL Phase Noise Single Sideband	PN <sub>PLL,100kHz</sub>	dBc/Hz		-80	-75	@100kHz offset

## PLL Domain Functional Specification

### 6.3.1 Frequency Ramp Linearity Definition:

Frequency ramp linearity error is defined to be <1% of the FM-chirp bandwidth. The linearity error is calculated as the deviation from an “ideal” frequency ramp. The specification needs to be fulfilled after the frequency ramp settling time (see also section 3.3). The assumed worst-case FM-chirp bandwidth for linearity evaluations is 2 GHz.

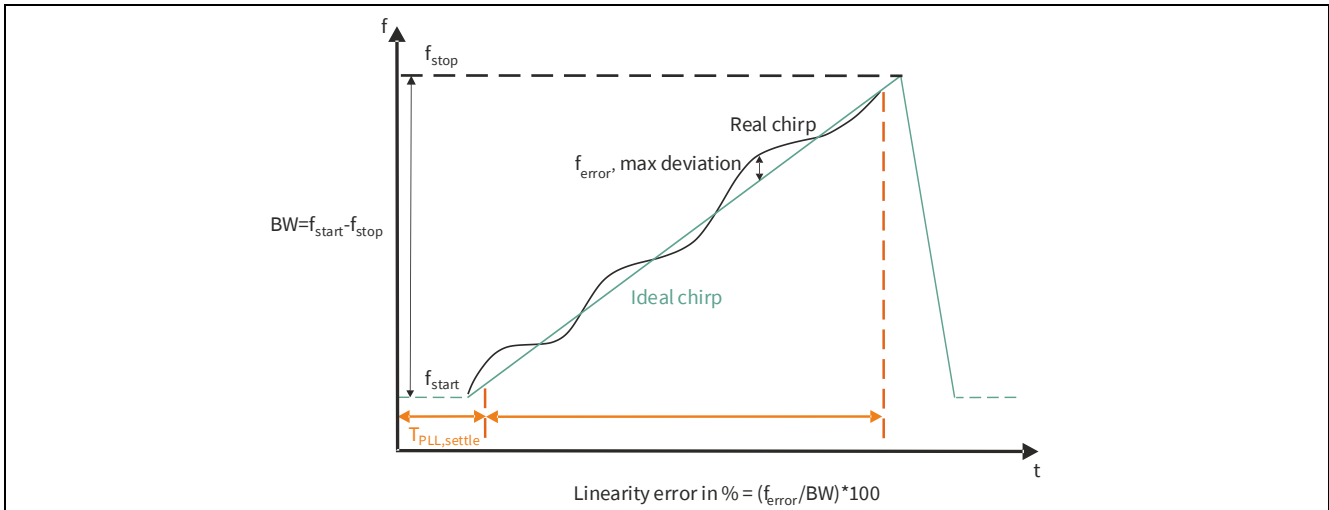

Figure 61 Frequency linearity definition

The max frequency error expected, assuming 2 GHz minimum BW and a max deviation of 1%, will be 20 MHz.

### 6.3.2 Frequency Ramp Settling Time

It is the time required by the PLL to damp undershoot and overshoot in case of saw-tooth shapes. A qualitative view is shown in Figure 62. See section 3.3 for a more detailed definition of the timings.

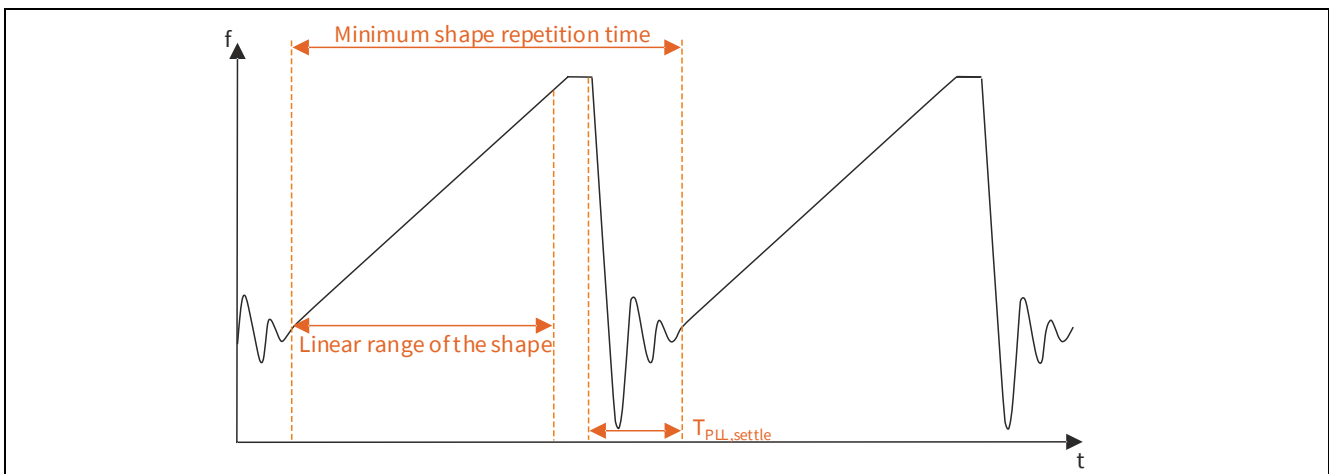

Figure 62 Chirp settling time

Analog-RF Domain Functional Specification

7 Analog-RF Domain Functional Specification

In the analog functional specification all analog components like RF frontend (RF FE), baseband amplifiers, and filters are described in more details.

The register definitions for the components are in section 4.10.

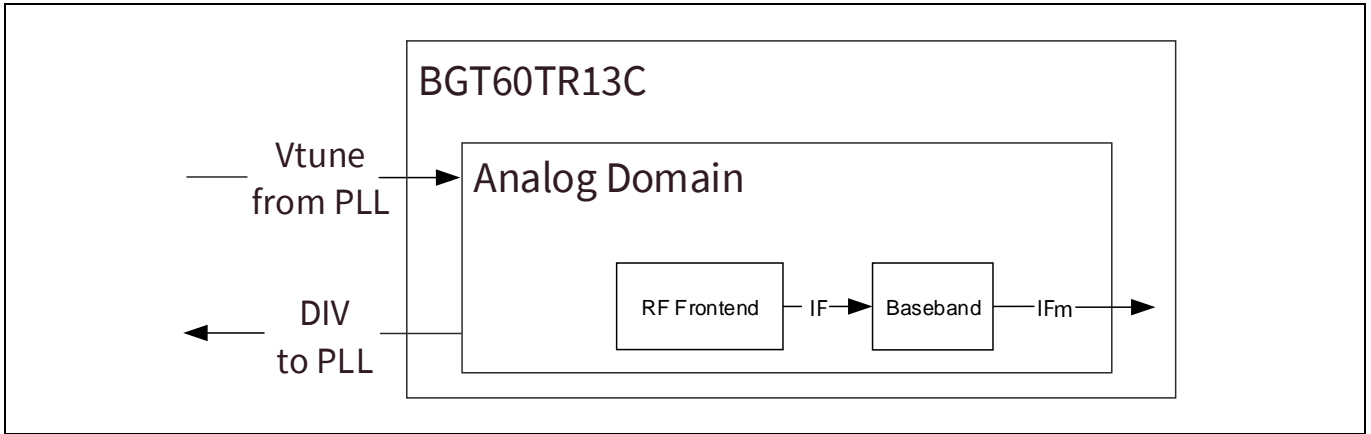

Figure 63 Analog domain simplified block diagram

7.1 RF Frontend (RF FE)

In the RF frontend, all features to enable the radar functionality are implemented.

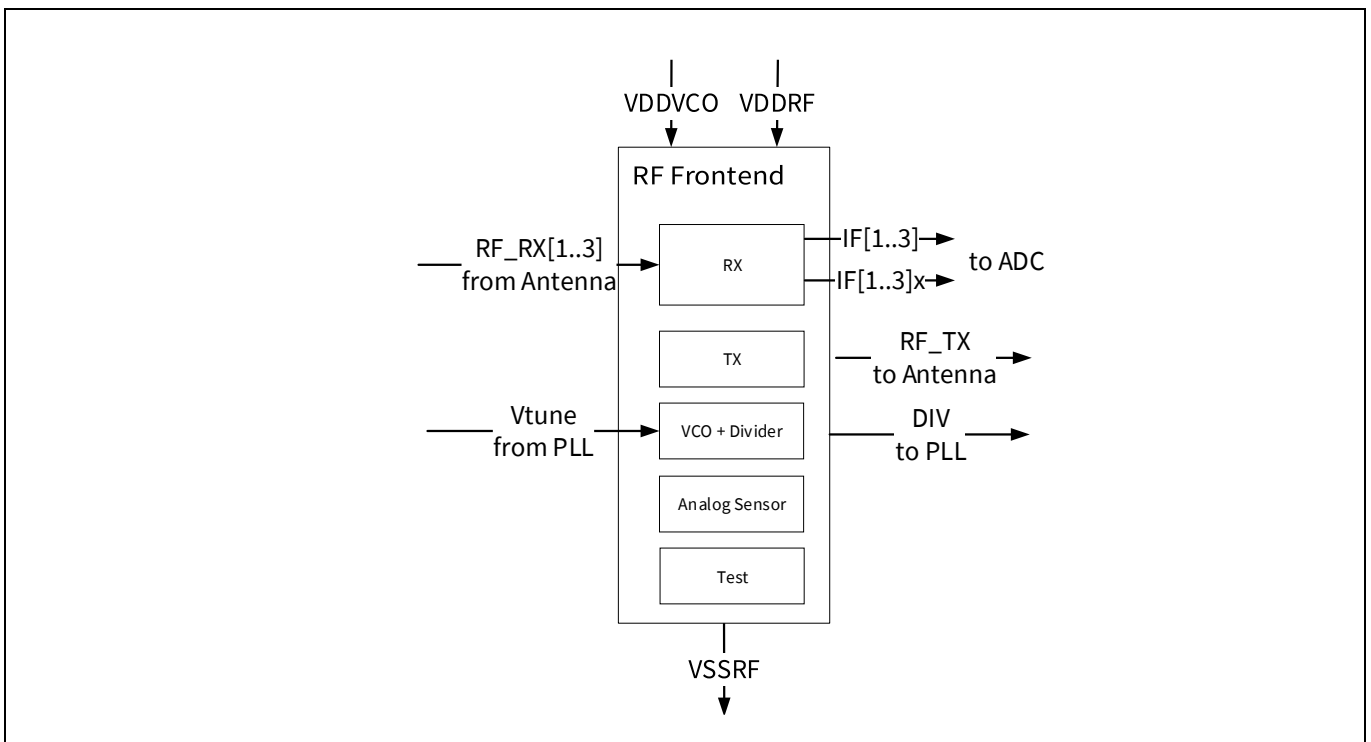

Figure 64 Simplified block diagram of BGT60TR13C transceiver frontend

7.1.1 On-Chip Analog Sensor Output

The analog sensor outputs are connected to the SADC. See section 4.9 for the SADC input configuration. See also section 4.10 for enable pins definition.

Analog-RF Domain Functional Specification

7.1.2 RF FE Specifications

In the table below the target specifications for the RF frontend measured at die PAD interface.

**Table 55 RF FE Specifications**, min and max values cover the specified frequency range,  $f_{RF} = 58.0$  to  $63.5$  GHz. Temperature range,  $T_b = -20$  to  $+70$  °C, and voltage supply range,  $V_{DDRF} = 1.71$  to  $1.89$  V (unless otherwise specified)

Spec	Symbol	Unit	Value			Condition
			Min	Typ	Max	
Parameter			Min	Typ	Max	
Frequency Range	$f_{RF}$	GHz	58.0		63.5	
<b>Transmitter</b>						
Transmit Output Power <sup>1)</sup>	$P_{TX}$	dBm	1.0	4.0	8.0	Conductive Power
Output Power Variation over Temperature	$P_{TX\_Temp}$	dB	-2.0		+2.0	For Tx DAC set to #31
Transmitter Power Control Dynamic Range	$P_{TXD}$	dB		15		
DAC Resolution Transmitter Power Control	$P_{TXC}$	Bits		5		By design
<b>Receiver (for all three RX channels)</b>						
Receiver Conversion Gain <sup>2)</sup>	$CG_{RX}$	dB	12	14	16	
Conversion Gain Variation Over Temperature	$CG_{RX\_Temp}$	dB	-3		+3	Including the complete baseband chain
Receiver Single Sideband Noise Figure	$NF_{SSB_{RX}}$	dB		12	14	@100kHz offset
Receiver 1-dB Compression Point	$P-1dB_{RX}$	dBm	-10	-5		
Channel-to-Channel RX Isolation <sup>3)</sup>	$ISO_{RX}$	dB		40		
LO feedthrough at the RX port <sup>3)</sup>	$LO_{feed_{RX}}$	dBm		-30		
TX-to-RX Isolation <sup>3)</sup>	$ISO_{TXRX}$	dB		50		
<b>Sensors</b>						
Temperature Sensor Range	$T_b$	°C	-40		105	
Chip Backside Temperature (Temp) Vs Temperature Sensor Readout (Tsense) Relation	Temp Tsense	°C V	$Temp = \frac{Tsense - a}{b}$			
Temperature Sensor Offset (a)	a	V	0.77384	0.78984	0.80584	
Temperature Sensor Slope (b)	b	V/K		0.00286		
Output Power at Chip Pad Vs TX Peak Detector Readout Relation	Pout  PPD_PA <sup>4)</sup>	dBm  V	$P_{out} = t_1 * \ln\left(\frac{PPD\_PA + y_0}{A_1}\right)$ $y_0 = 0.00836$ V $A_1 = 0.09972$ V $t_1 = 8.82773$ dBm			PPD_PA selected at SADC input
TX Peak Detector Accuracy	PPD_PAacc	dB	-2		+2	Over $f_{RF}$
TX Peak Detector Dynamic Range	PPD_PA <sub>DR</sub>	dBm	-10		+10	Min. 8 bits SADC

<sup>1)</sup>: at die pad

<sup>2)</sup>: power to voltage gain;

## Analog-RF Domain Functional Specification

<sup>3)</sup>: not including the package

<sup>4)</sup>: output power can be evaluated by sampling the level of the peak detector level at the output of the TX power amplifier. This signal has to be compared to a reference to de-embed thermal drift of the sensor. Therefore, both signals on channel SADC:CH3 (pd\_out) and SADC:CH4 (pd\_outx) are sampled by the SADC in two consecutive steps. PPD\_PA= pd\_out - pd\_outx. See section 4.9.

*Note: The 80 MHz spur clock signal could affect the SADC the readout (+/- 10mW). In order to have a more stable read out for the sensors, 16 avg for each sensor measurement are recommended.*

### 7.2 Analog Baseband: Amplifiers and Filters

The baseband amplifiers and filters adjust the IF signals to fulfill the system requirements. They set the signal levels to drive full scale the ADC inputs without clipping.

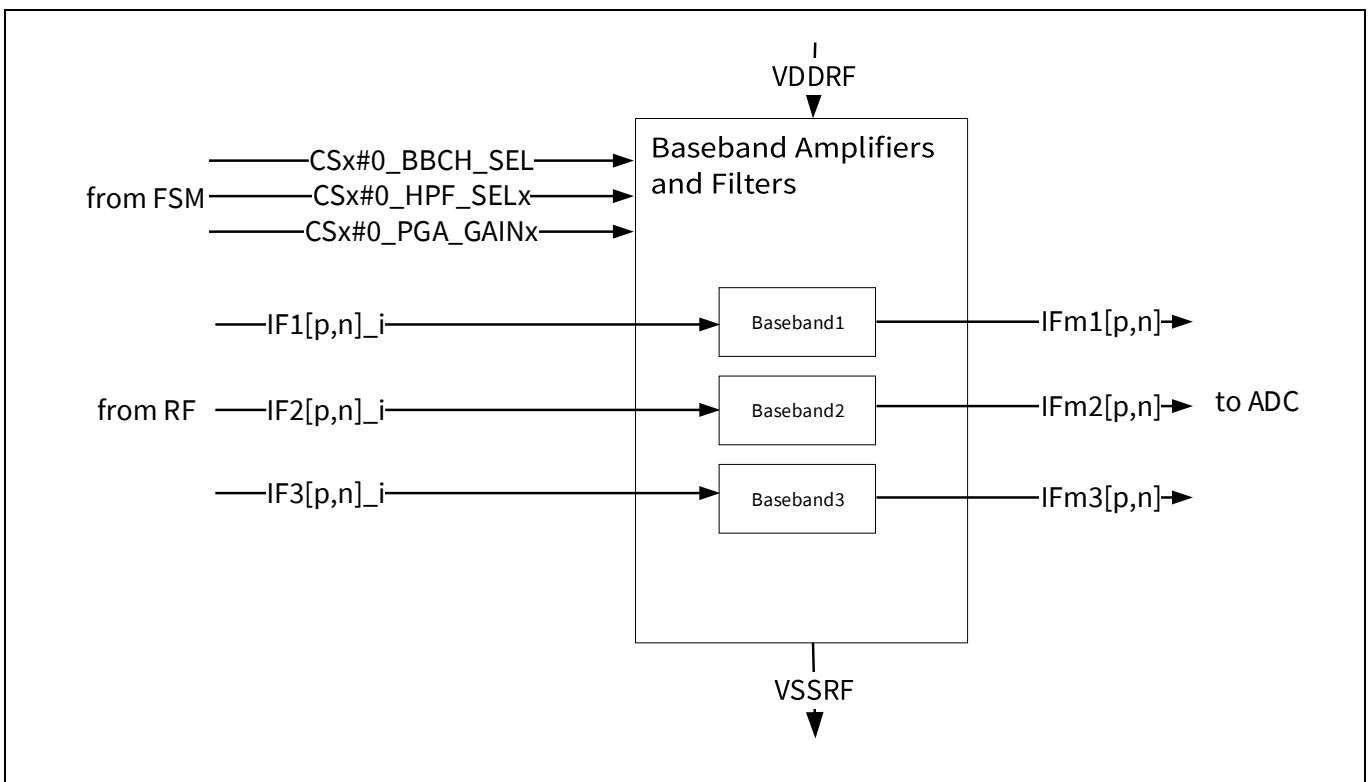

Figure 65 Baseband amplifiers and filters block diagram

## Analog-RF Domain Functional Specification

### 7.2.1 Baseband Characteristics

The baseband block consists of three channels. Each channel consists of a high pass filter (HPF), a variable gain amplifier (VGA), and anti-aliasing filter (AAF) plus a driver for the ADC (see Figure 67).

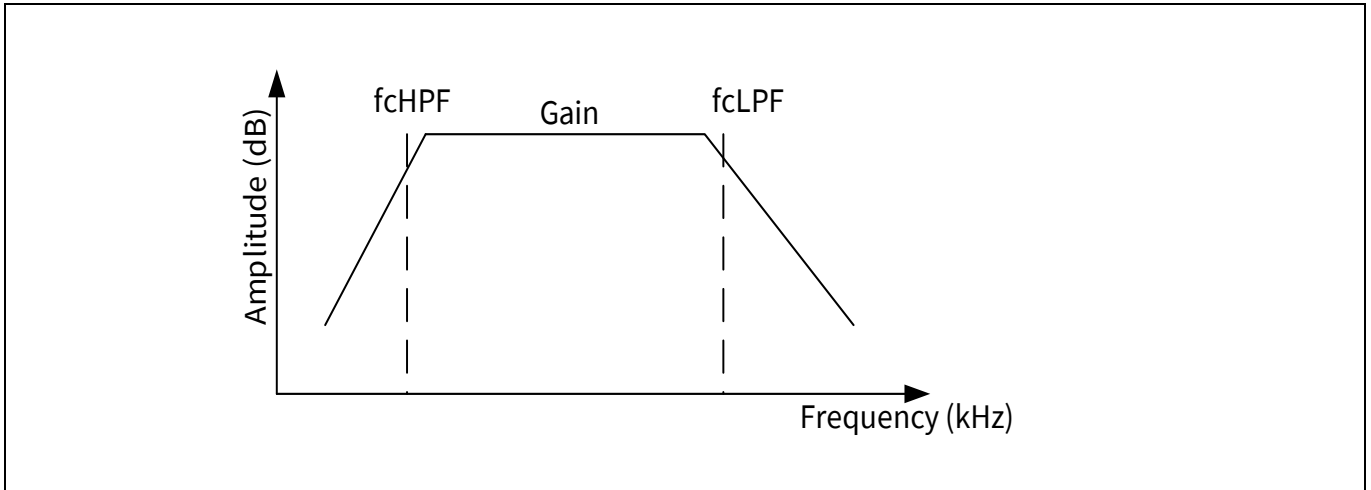

Figure 66 Baseband characteristic

The high pass filter is used in order to remove the DC-offset at the output of the RX mixer and also suppress the reflected signal from close in unwanted targets (e.g., radome).

### 7.2.2 Baseband Requirements

The high pass filter can be tuned to accommodate different  $f_{cHPF}$  according to different modulation parameters. As presented in Table 56 four different settings are possible.

Given the expected power levels the radar system will deal with, the HPF should not degrade the linearity of the system.

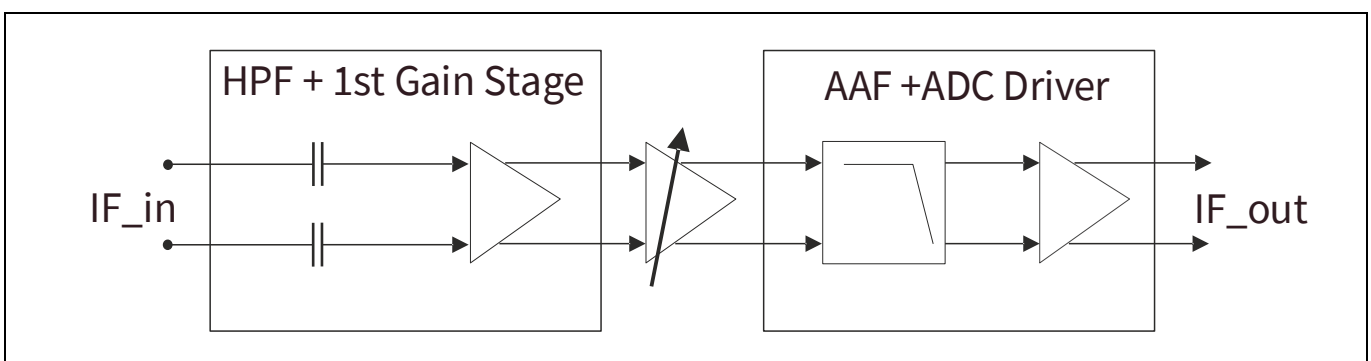

Figure 67 Baseband simplified block diagram, one for each channel

After the AC-coupling, the IF signals are amplified by the first amplifier stage. The first stage shows a selectable voltage gain of 18 or 30 dB. The gain can be adjusted in the VGA in 6 steps of 5 dB each up to a maximum gain of 30 dB. The VGA is followed by a two-stages, four-poles antialiasing filter. The signal is then applied to an ADC driver amplifier, which has a gain of 1. Overall, the baseband chain can be set to a maximum gain of 60 dB.

The specific parameters of the baseband chain are summarized in Table 56, Table 56, and Table 57

## Analog-RF Domain Functional Specification

**Table 56 High Pass Filter Selection.** VDDRF = 1.71 to 1.89 V, Tb = -20 to +70 °C

Spec	Unit	Value			Description
		Min	Typ	Max	
Parameter		Min	Typ	Max	
Fc_HPF_0	kHz	12	20	28	HPF 3 dB cutoff frequency
Fc_HPF_1	kHz	32	40	48	HPF 3 dB cutoff frequency
Fc_HPF_2	kHz	63	70	93	HPF 3 dB cutoff frequency
Fc_HPF_3	kHz	65	80	95	HPF 3 dB cutoff frequency

**Table 57 Baseband Gain Stages,** VDDRF = 1.71 to 1.89 V, Tb = -20 to +70 °C

Spec	Unit	Value			Description
		Min	Typ	Max	
Parameter		Min	Typ	Max	
1 <sup>st</sup> Gain Stage	dB		18/30		Selectable, by design
VGA	dB		30		6 steps
VGA Step Size	dB	4	5	6	

**Table 58 Antialiasing Filter Specification,** VDDRF = 1.71 to 1.89 V, Tb = -20 to +70 °C

Spec	Unit	Value			Description
		Min	Typ	Max	
Parameter		Min	Typ	Max	
fcLPF	kHz	450	500	650	3 dB cutoff frequency
LPF_Order			2 <sup>nd</sup>		Four poles, by design
LPF_Flatness	dB		1		In band flatness, guaranteed by design



MADC Domain Functional Specification

8 MADC Domain Functional Specification

The multichannel ADC (MADC) block consists of three differential SAR ADCs. The three ADCs are capturing the three differentials IF output signals from the baseband and convert them into a digital representation of the same. The one 1.5 V supply (VDDC) is internally generated by a dedicated LDO (see Figure 4). This block is enabled by bit MADC\_EN in Table 30, parameters are set in 4.3. Each channel of the MADC can be enable/disable together with the respective baseband channel by the bits BBCH\_SEL in Table 30. To simplify the dataflow to the memory either one single ADC channel, two single ADC channels or three single ADC channels can be selected via the BBCH\_SEL in Table 30. See also APU and APD in Table 37 and paragraph 5.2.

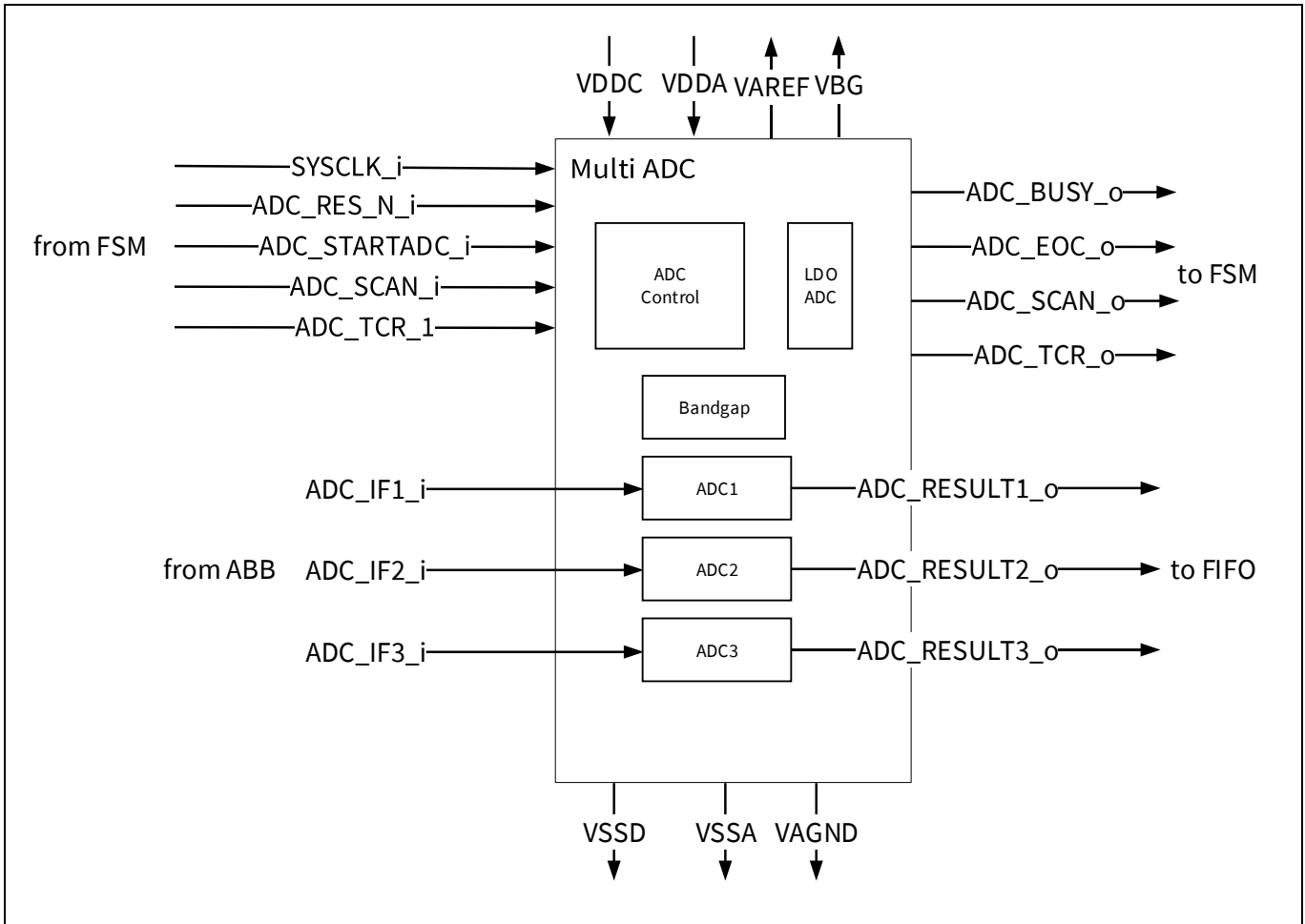
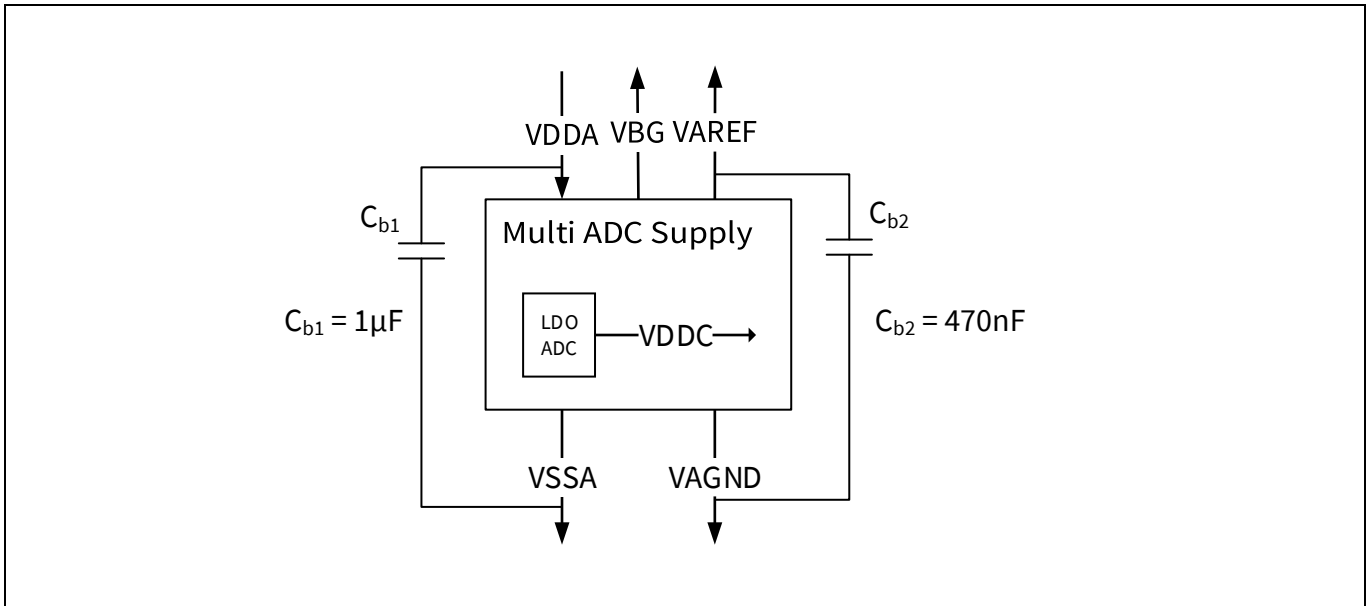

Figure 68 MADC block diagram

8.1 MADC Supply Voltage Requirements

The voltage supply to the ADC domain is provided on pin VDDA and the output of the internal ADC reference voltage is provided on pinVAREF. In order to filter out the voltage ripples due to switching effects a low ESR bypass capacitor of  $C_{b2} = 470 \text{ nF}$  should be used on the PCB.

**MADC Domain Functional Specification**



**Figure 69 MADC input pin requirements**

Both ground connection pins VSSA and VAGND share the same analog ground connection on PCB. The bypass capacitors should be mounted as close as possible to those pins.

**Table 59 MADC Voltage Reference, VDDA = 1.71 to 1.89 V, T<sub>b</sub> = -20 to +70 °C**

Spec	Symbol	Unit	Value			Condition
			Min	Typ	Max	
Parameter			Min	Typ	Max	
Positive reference voltage with respect to VAGND, generated internally	VREFP	V	1.14	1.2	1.26	
Negative analog reference voltage	VAGND	V	0		0.1	Refers to board design ground plane

**8.2 MADC Specifications**

Table 60 below specifies the ADC parameters. The numbers include one over-conversion. All parameters are only valid with executed startup calibration. No parameter is targeted for production test.

Note:

$$f_{ADC\_CLK} = f_{SYS\_CLK}$$

**REMARK:**

If the ADC starts sampling before the bandgap is powered up (BG\_EN in Table 32), the results will show some gain errors. To avoid this, follow the bandgap power up timing presented in section 8.4.

**Table 60 MADC Specifications, VDDA = 1.71 to 1.89 V, T<sub>b</sub> = -20 to +70 °C**

Spec	Symbol	Unit	Value			Condition
			Min	Typ	Max	
Parameter			Min	Typ	Max	
Resolution				12		With default settings and

## MADC Domain Functional Specification

Table 60 MADC Specifications, VDDA = 1.71 to 1.89 V, T<sub>b</sub> = -20 to +70 °C

Spec	Symbol	Unit	Value			Condition
						tracking conversion Table 63
Analog input voltage	V <sub>A</sub>	V	0.145		1.455	
ADC Clock Frequency	f <sub>ADC_CLK</sub>	MHz	75	80	85	f <sub>ADC_CLK</sub> = f <sub>SYS_CLK</sub> See 2.2 78 MHz not allowed
Signal to noise ratio	SNR	dB	55	64		@ -6dB FS
Spurious free dynamic range	SFDR	dB	58	69		@ -6dB FS @ 600kHz
Inter modulation product	IM3	dB	62	69		@ -12dB FS each input tone @ 600kHz max f @ 50KHz Δf
Bandwidth input buffer	BW	kHz	600			1 <sup>st</sup> order Filter in input Buffer
Conversion time – excluding sample time	Nconv	Counts of clk		24		Including one tracking conversion, sampling time not included
Sampling time	T <sub>s</sub>	Counts of clk	4	8		@ 80 MHz clk
Wake up time – bandgap and BG reference Buffer	T <sub>WUBGB</sub>	us	300	600	1000	
Wake up time – ADC	T <sub>WUADC</sub>	Counts of clk		660		without startup calibration
Startup calibration time <sup>1)</sup>	T <sub>SUCAL</sub>	Counts of clk	3361	6049	16801	ADC0:DSCAL= 0 <sub>B</sub> Typical conditions: ADC0:STC=1 <sub>B</sub> ADC0:MSB_CTRL= 1 <sub>B</sub>
Setup time common mode input voltage	T <sub>VCM</sub>	μs			1	
Power supply Rejection Ration on VDD5	PSRR	dB	20			

\* Parameters guaranteed by design

$$1) T_{SUCAL} = (1792 * 2^{\text{ADC0:STC}} + 896 * \text{ADC0:MSB\_CTRL} + 1569) * 1/f_{\text{SYS\_CLK}}$$

$$2) \text{Overall wake up time when calibration time is enabled} = T_{WUADC} + T_{SUCAL}$$

## MADC Domain Functional Specification

### 8.3 MADC Timing Diagrams

The interface is fully synchronized to the main clock. Figure 70 shows the 12 bits conversion timing in case of one tracking and no oversampling. Thus, the maximum speed of the ADC is set to 2.5 MSps at 80 MHz clock input. Figure 70 shows the SAR ADC timing.

**Important:** all configuration signals must be stable during a running conversion (between start\_adc and one cycle before eoc).

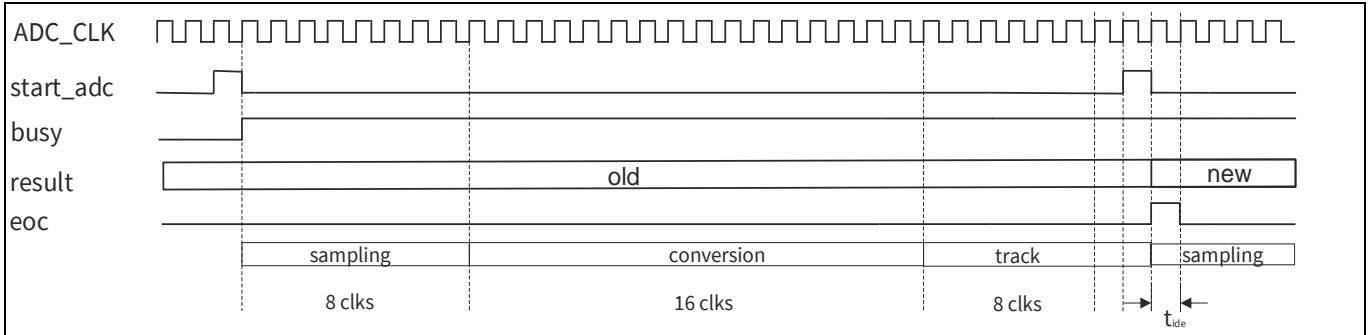

Figure 70 SAR ADC conversion timing diagram, 12 bits

### 8.4 MADC Startup Sequence

The following figure shows the startup sequence for the complete ADC.

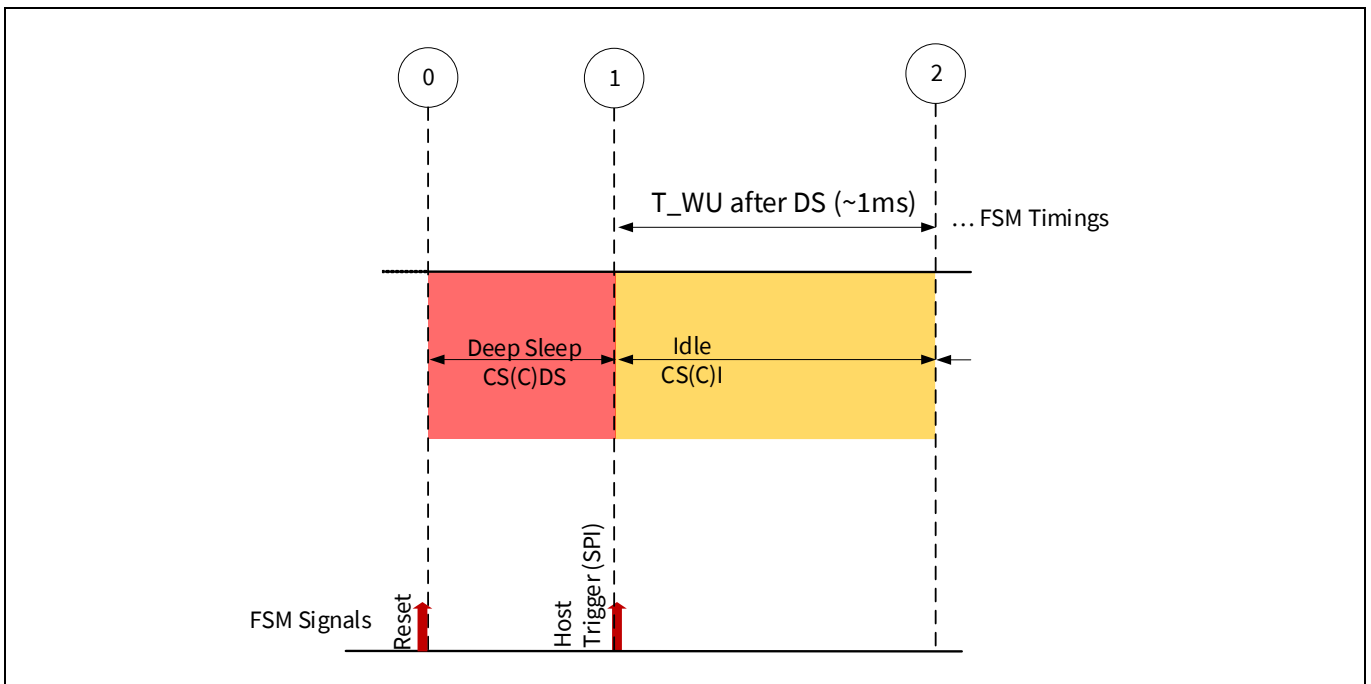

Figure 71 MADC start-up timing constraints

After a reset and trigger from the host, the FSM will move from the deep sleep mode into the idle mode. Here  $T_{WKUP}$  represents the overall time required by the bandgap to settle and it is the longest time required in the settling of the ADC.

The following Table 61 shows the start-up timing constraints:

## MADC Domain Functional Specification

**Table 61 MADC Timing Constraints, VDDA = 1.71 to 1.89 V, T<sub>b</sub> = -20 to +70 °C**

Spec	Symbol	Unit	Value			Condition
			Min	Typ	Max	
Parameter						
Wake up time	T <sub>WUADC</sub>	μs		8.25		@80 MHz
Setup time common mode input voltage	T <sub>VCM</sub>	μs			1	
Wake-up time for bandgap and bandgap reference buffer	T <sub>WU</sub>	μs	300		1000	

### 8.5 MADC Conversion Rate

The ADC clock input is  $f_{\text{ADC\_CLK}} = f_{\text{SYS\_CLK}} = 80 \text{ MHz}$  and is derived from the system clock.

A conversion can include three different phases:

- Sampling
- Conversion
- Tracking

#### 8.5.1 Sampling

During the first phase, the analog input voltage is sampled onto the input capacitor. The duration is controlled using the ADC0:STC bits. The following Table 62 shows the link between the register value ADC0:STC the clock periods STC\_NUM and the sampling time.

**Table 62 ADC0:STC Value Table (see section 4.3)**

	Sampling clock periods	Sampling time in ns ( $f_{\text{ADC\_CLK}} = 80 \text{ MHz}$ )
ADC0:STC	STC_NUM	t <sub>sample</sub>
0 <sub>D</sub>	4	50
1 <sub>D</sub> (default)	8	100
2 <sub>D</sub>	16	200
3 <sub>D</sub>	32	400

The sampling time is calculated as:  $N_{\text{sample}} = \text{STC\_NUM}$

#### 8.5.2 Conversion

The charge from the sampling capacitor is redistributed to 13 + 2 capacitors. To identify the LSB bits of the result, 13 clock cycles are needed.

To identify the MSB bit of the result, one or two clock cycles are used, depending on register setting ADC0:MSB\_CTRL:

- In case of MSB\_CTRL is set to 0<sub>B</sub>, just a single (1) clock cycle is used
- In case of MSB\_CTRL is set to 1<sub>B</sub>, two (2) clock cycles are used

The redistribution time is calculated as:

$$N_{\text{conv}} = (13 + 2 + \text{ADC0:MSB\_CTRL})$$

## MADC Domain Functional Specification

### 8.5.3 Tracking

In this mode, the ADC performs a single sample conversion followed by several tracking conversions, depending on the setting of bits ADC0:TRACK\_CFG:

**Table 63 ADC0:TRACK\_CFG Value Table**

ADC0:TRACK_CFG	Additional conversions TRACK_CFG_NUM	Remarks
0 <sub>D</sub>	0	
1 <sub>D</sub>	1	Default
2 <sub>D</sub>	3	
3 <sub>D</sub>	7	

The duration of one tracking conversion is:

$$N_{\text{track}} = 8$$

The duration of all tracking conversions for a single result is then:

$$N_{\text{track\_all}} = 8 \times \text{TRACK\_CFG\_NUM}$$

### 8.5.4 ADC Conversion Rate

Based on what defined in 8.5.1, 8.5.2, and 8.5.3 the following cycles are defined for a single conversion:

$$N_{\text{ADC\_CONV}} = N_{\text{samp}} + N_{\text{conv}} + N_{\text{track\_all}}$$

with  $N_{\text{samp}}$  the number of sampling,  $N_{\text{conv}}$  conversion and  $N_{\text{track}}$  tracking cycles, respectively.

All ADCs are synchronized to  $f_{\text{SYS\_CLK}}$ .

### 8.5.5 ADC Sampling Rate

The ADC sampling rate is controlled by the ADC0:ADC\_DIV value (see Table 22). The sampling rate of the ADC is given then by  $f_{\text{ADC\_SAMP}} = f_{\text{ADC\_CLK}} / \text{ADC\_DIV}$ . ADC0:ADC\_DIV value needs to be greater than the number of clock cycles needed by a single ADC conversion as described in 8.5.4.

The sampling rate of the ADC is:

$$f_{\text{ADC\_SAMP}} = f_{\text{ADC\_CLK}} / \text{ADC\_DIV}$$

$$\text{with } \text{ADC\_DIV} > N_{\text{ADC\_CONV}}$$

**Table 64 ADC Sampling Rate, VDDA = 1.71 to 1.89 V, T<sub>b</sub> = -20 to +70 °C**

Spec	Symbol	Unit	Value			Condition
			Min	Typ	Max	
Parameter						
ADC sampling rate	$f_{\text{ADC\_SAMP}}$	MHZ		2	4	
Effective number of bits resolution	ENOB	1		10.5		

## SADC Domain Functional Specification

### 9 SADC Domain Functional Specification

The Sensor ADC (SADC) is a single channel single-ended 8 bits SAR ADC.

The sensor ADC can be used to monitor the temperature output as well as the power detector outputs from the transmitter channels. Conversion data can be read out through the SADC register (see also section 4.22). The data can be added also to the header of MADC data frame in the FIFO (see also section 5.1). By default, the SADC is set to read out the temperature sensor out (SADC\_CTRL:SADC\_CHSEL=0 in section 4.9). For additional settings, please check section 4.9. See also Figure 72. The SADC can achieve a better resolution of 10 bits by means of oversampling (see section 9.2).

Due to the required conversion time, ADC data are not available during a shape, but they would be available during next shape (there is a delay of one shape for these data).

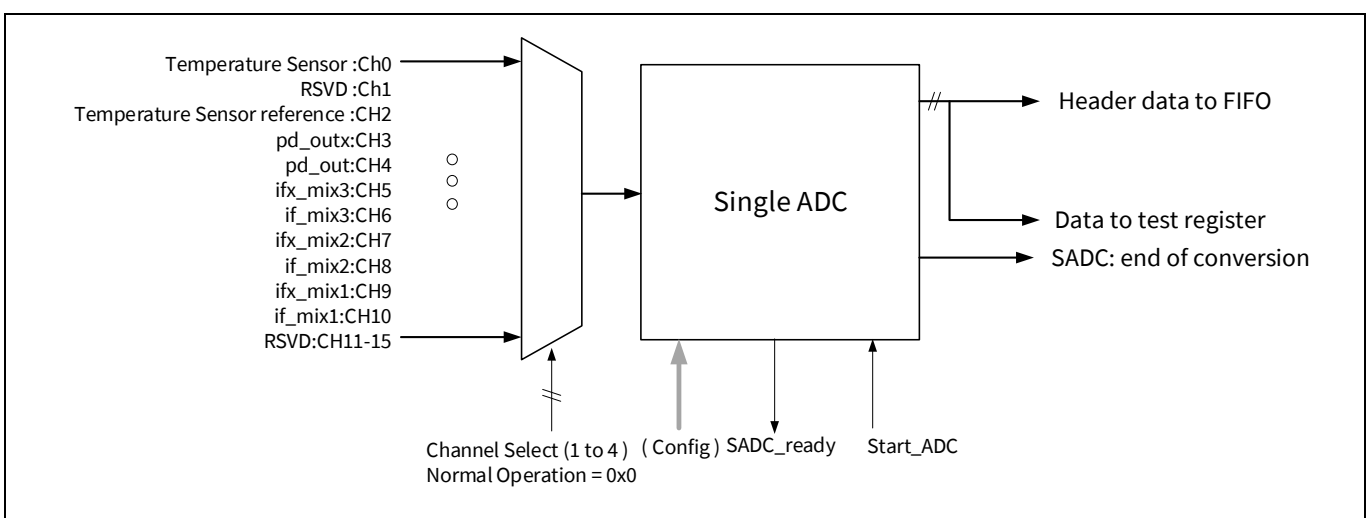

Figure 72 SADC Integration

#### 9.1 SADC Functionality

Four main tasks are performed by the FSM to control the SADC:

- Enabling:
  - The SADC module is enabled through the CSCx register in any phase of the FSM state (see also 4.11)
- Initialization:
  - The host selects the channel in the channel register from SADC\_CTRL control register (see also section 4.9)
- Triggering:
  - Each chirp-start during the active phase of shapes will trigger the SADC sampling/conversion
  - or by sending a SADC\_START to SADC\_CTRL register (see section 4.9)
- Results:
  - The conversion results are stored in the result register SADC\_RESULTS register (see section 4.22) after the sampling and conversion is completed

**SADC Domain Functional Specification**

**9.2 SADC Conversion Formula**

The SADC clock signal is running at 20 MHz and is derived from  $f_{ADC\_CLK} = f_{SYS\_CLK} = 80$  MHz. The SADC startup time is 101 clock cycles without startup-calibration and 422 clock cycles with startup-calibration. If temperature or power supply conditions did not change dramatically, the startup-calibration can be avoided during frames.

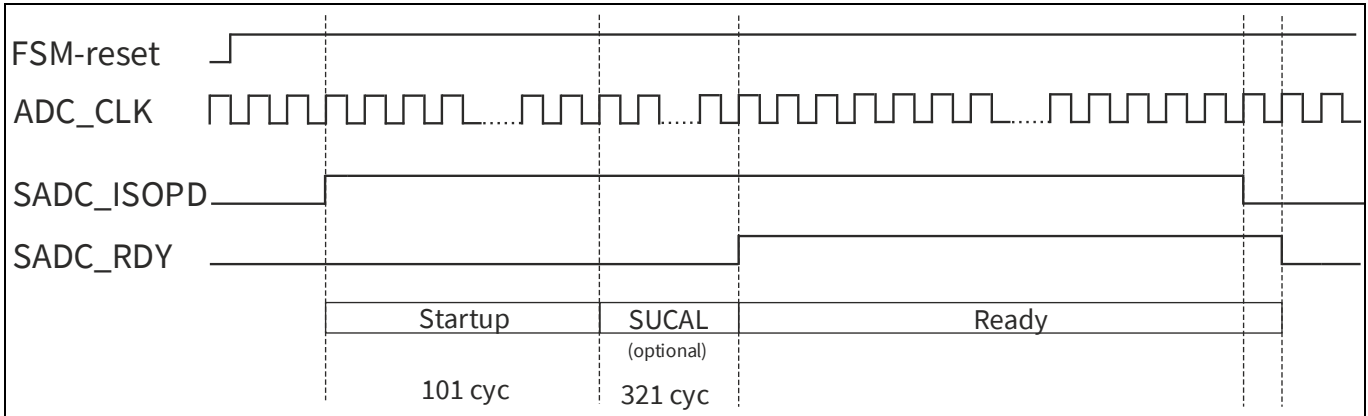

**Figure 73 SADC startup timing**

The conversion time  $N_{CONV\_LEN}$  for a single analog to digital conversion into the result register SADC\_RESULT (see section 4.22) is defined by the following relation:

$$N_{CONV\_LEN} = (N_{conv} + N_{sample\_dflt} + SESP \times N_{spread\_early\_sample}) \times OVS$$

Where:

$N_{conv} = 13$  clock cycles

$N_{sample\_dflt} = 16$  clock cycles

$N_{spread\_early\_sample} = 16$  clock cycles

OVS ... see SADC\_CTRL:OVERS\_CFG (see section 4.9)

SESP ... see SADC\_CTRL:SESP (see section 4.9).

The SADC conversion formula for 8 bits resolution is:

$$Dout_{8b} = ((2^8 \times V_{Ain}) / VREFP) \times G_{Ain} \text{ with an error of } \pm 0.1\%$$

Where:

$V_{Ain}$  is the analog input to the SADC

$G_{Ain}$  is the gain of the ADC module and can be set either to 1 or 0.75 (see section 4.9)

$VREFP = 1.21V$ .

In order to achieve 10 bits resolution, the oversampling should be set to 32 (see section 4.9).

In order to measure correctly the power sensor output, see sections 7.1.2 and 4.9.

*Note: Disabling the SADC*

To disable the SADC simply set in register CSCx (see section 4.11) SADC\_ISOPD= '0<sub>B</sub>' ( $f_{SYS\_CLK}$  has to be still provided for at least one additional cycle for the command to take effect).



## Enhanced Functions

### 10 Enhanced Functions

#### 10.1 Data Test Mode

A linear feedback shift register (LFSR) is built-in on chip. It will generate a pseudo random bit M-sequence that can be used to fill up the FIFO. This can be used to develop and test the complete pipeline from the FIFO on the BGT60TR13C up to the Application Processor (AP) memory, including firmware and drivers, with a defined bit sequence.

The implemented LFSR is described by the following polynomial:  $x^{12}+x^{11}+x^{10}+x^4+1$ .

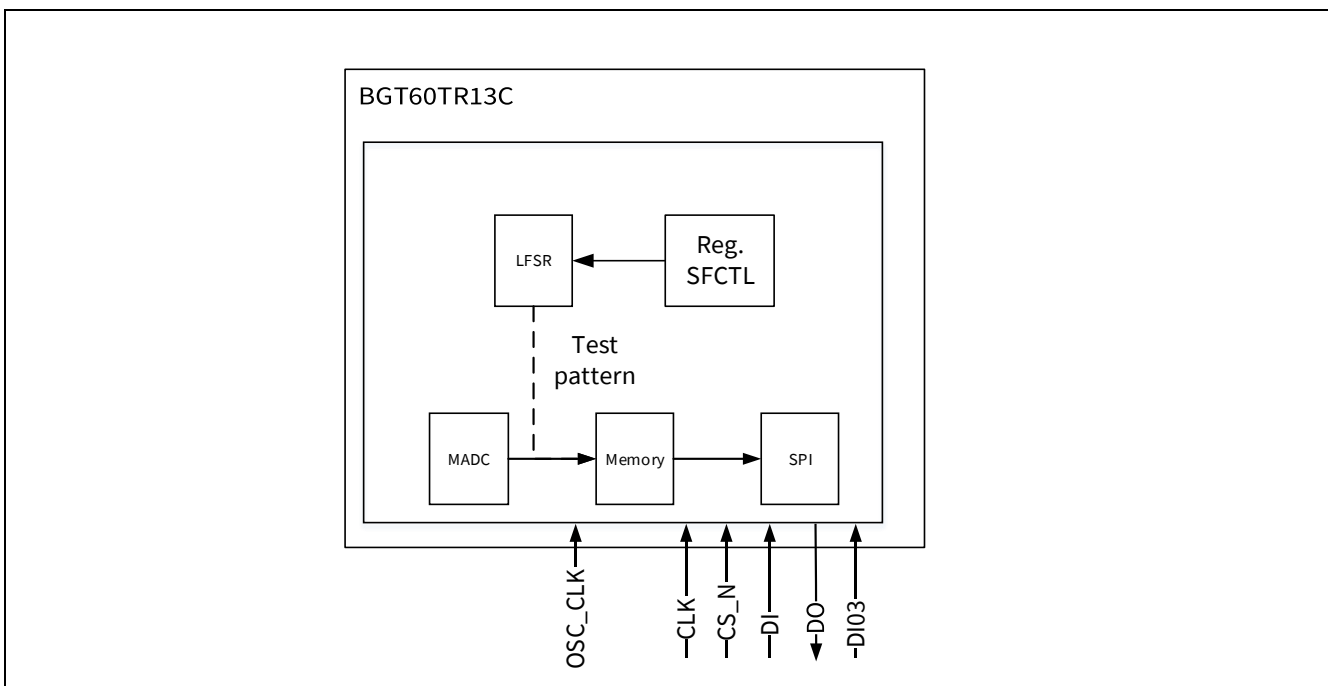

**Figure 74 Digital pipeline simplified block diagram**

The first ADC channel ADC\_CH1 output data stream is bypassed by the data sequence coming from the LFSR generator.

The other channels can be disabled or used in normal operation.

- This test mode can be started with bit SFCTL:LFSR\_EN= 1<sub>B</sub> (see also 4.8):
- Activate test data instead of ADC data
- Initialization with MAIN:FSM\_RESET= 1<sub>B</sub>

#### 10.2 CW Mode

In the continuous wave (CW) mode the device will be set to provide a constant output frequency. During CW mode no shapes are executed.

During the execution of this mode:

- Freq/timing parameters defined in shape registers are ignored
- PLL / RF / ADC runs with values programmed in PLL DFT0 (4.18) and CSU1 (0).
- All other CSx / shape settings are not handed over to functional blocks

## Enhanced Functions

- The values for REPS/REPC/REPT and frame relevant timings are used to shape a “virtual frame”
- Data from the FIFO can be read out following the structure of that “virtual frame”

Note:

For test purposes the “virtual frame” definition should be kept simple: 1 shape, 1 CS, e.g.

### 10.2.1 Enabling the CW mode

The CW mode should be preceded by either an HW or SW reset.

After this in order to enable the CW mode, the steps below should be followed:

- Enable the MAIN: CW\_MODE = 1<sub>B</sub> (see 4.2)
- Initialize the chip registers according to defined “virtual frame” (settings in 4.10 and 4.16)
- Enable the clock: PACR1: OSCCLKEN (see 4.6)
- Set frequency via PLLx: FSU setting from shape 1
- Set channel set for CSD/CSI/CSU1 (see 4.11)
- set PLL DFT0: BYPRMPEN = 1<sub>B</sub> (see 4.18)

By using the FRAME\_START as trigger, the chip can be set in the different states of a shape as shown in Figure 75:

- TRIG#1: jump to 1 (DS -> IDLE)
- TRIG#2: jump to 2 (IDLE -> INIT0)
- TRIG#3: jump to 3 (INIT0 -> INIT1)
- TRIG#4: jump to 4
- TRIG#5: jump to 6

Frequency update: at this stage the output frequency can be updated/programed (FSU) to any value and the current frequency will be updated immediately after PLL transition of DFT0: BYPRMPEN = 0<sub>B</sub> -> 1<sub>B</sub>.

- TRIG#6: jump to 7

At this stage, the APU number of samples is generated by the ADC according to the ADC0 settings. In case if APU=0 no triggers are generated, manual triggering of MADC can be done via ADC0: TRIG\_MADC. Once the APU number of samples is generated another automatic generation of samples can be done after FSM reset.

- 
- TRIG7: jump to 8
- TRIG8: jump to 10
- TRIG9: jump to 11
- TRIGx

Enhanced Functions

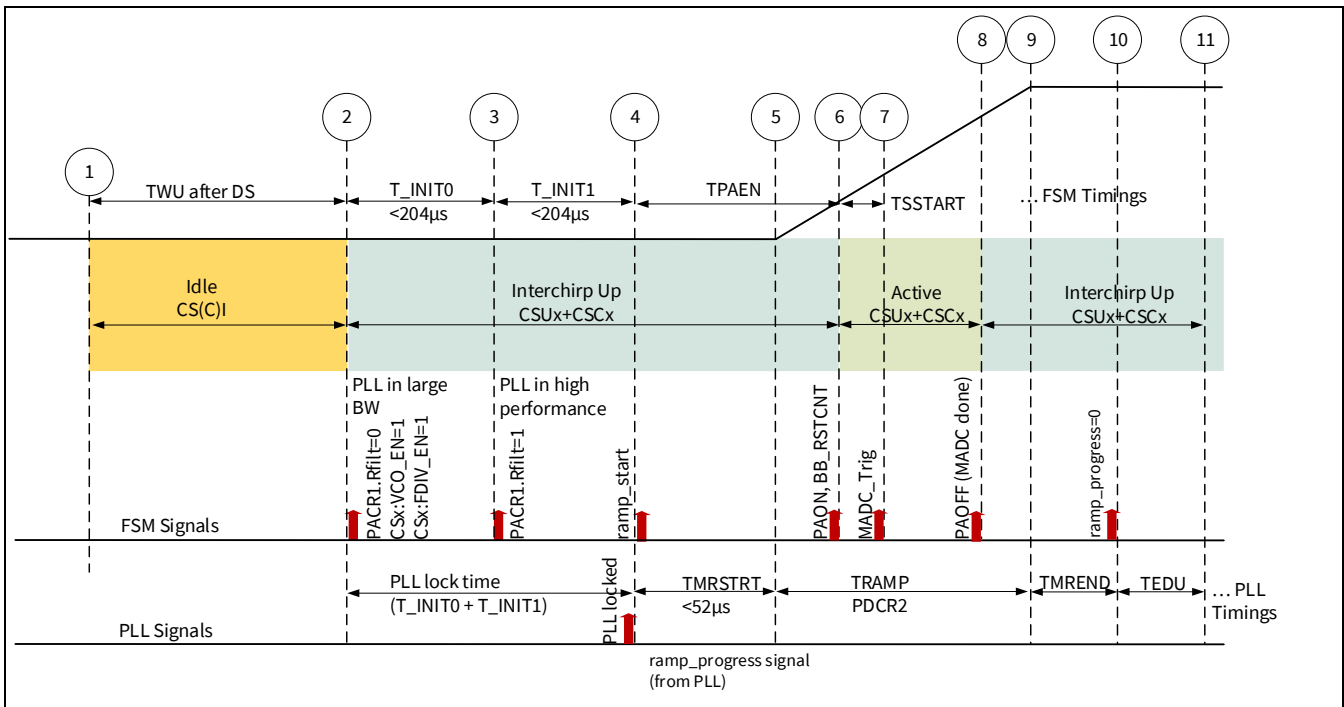

Figure 75 Steps that can be followed during a “virtual frame”

The FSM-reset will set back the FSM to initial state to start again with TRIG1.

This specific mode is intended also to test the power consumption of the chip during a specific sequence. It will offer the opportunity to break the expected shape that should be run during the radar (active) mode in static steps where the current consumption can be measured.

10.2.2 Baseband and ADC Test Mode

A test-tone generator can be used together with the CW mode. A test signal source derived from the OSC\_CLK input at 80 MHz can be activated in the analog receiver chain; the same in each Rx chain. This test signal can be programmed in the register RFT0 (see section 4.19). The test tone can propagate through to each baseband chain by enabling a dedicated path. The MADC is triggered by the TRIG7 in Figure 75 and will sample the number of samples specified in the APU1 (see section 4.16). To run a new measurement an FSM-Reset is required.

Enhanced Functions

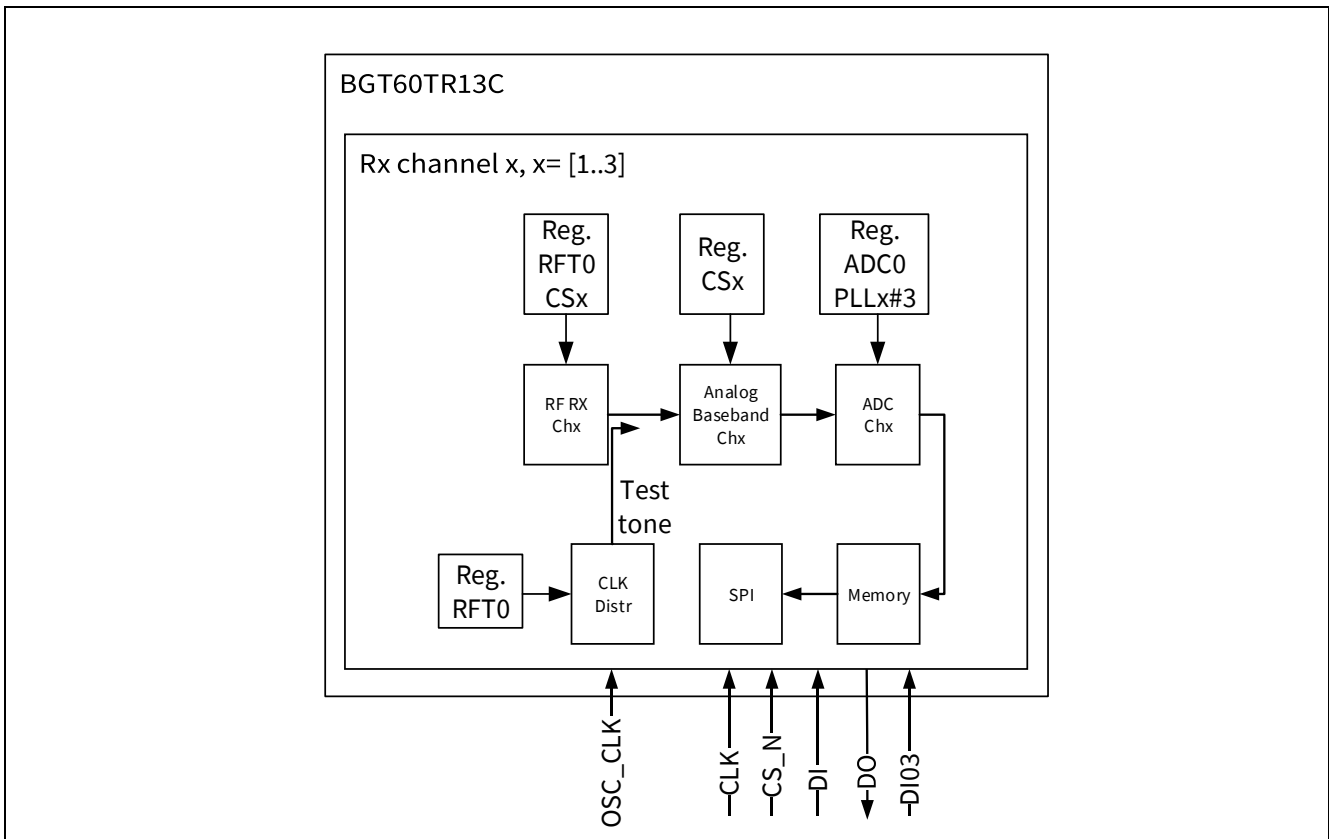

Figure 76 Baseband/ADC test block diagram

This feature represents a very convenient way to test and debug a complete system. The customer can program a dedicated frequency, set the baseband gain and cutoff filter of the HPF (0), set the ADC (see 4.3), and readout via SPI the sampled data into the application processor or microcontroller unit to verify if the complete baseband chain is working as expected.

In Figure 77 is reported one example of ADC readout when the baseband is fed with a test tone at 400kHz internally derived from the OSC\_CLK input. Different readouts from different VGA settings are reported.

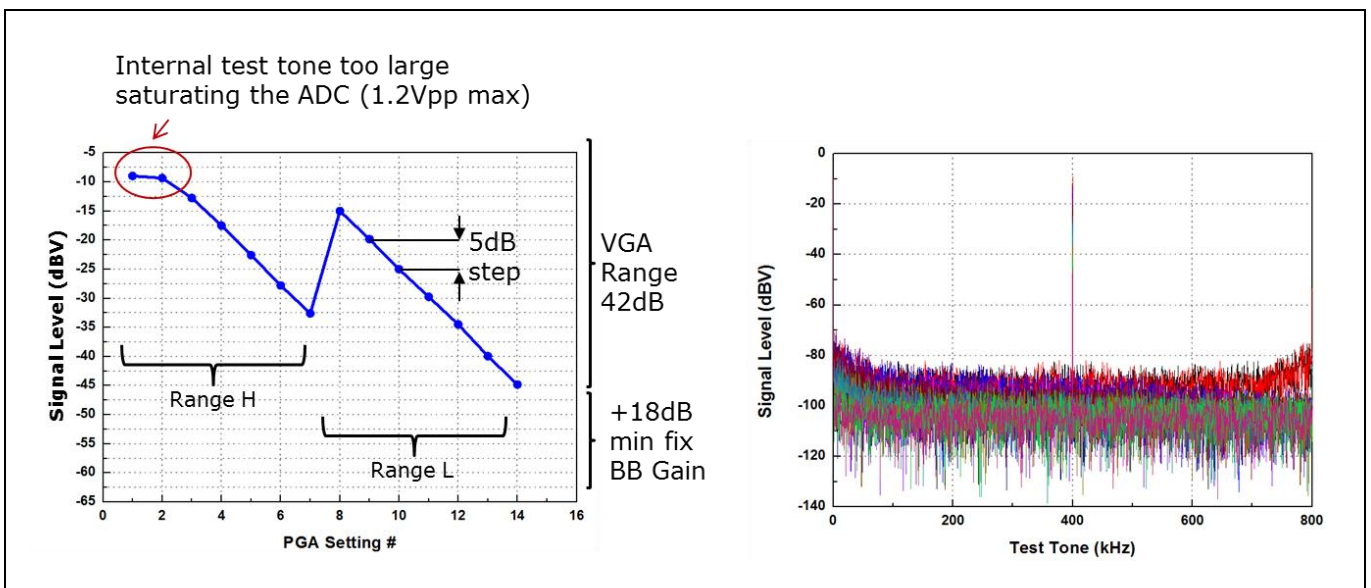

Figure 77 Example: ADC readout after FFT

**Enhanced Functions**

**10.3 IRQ Output**

BGT60TR13C provides one interrupt pin output (IRQ). In default mode, the IRQ signal is used to monitor the filling level of the FIFO as described below.

**IRQ status definition:**

- IRQ is high after:
  - CS\_N goes high and FSTAT:FILL\_STATUS >= SFCTL:FIFO\_CREF (see also 4.8 and 4.23).
- IRQ is low (as a consequence of):
  - CS\_N goes high and FSTAT:FILL\_STATUS < SFCTL:FIFO\_CREF (see also 4.8 and 4.23).
  - or CS\_N is active low

The following figure shows the IRQ signal in case of FIFO-burst reads.

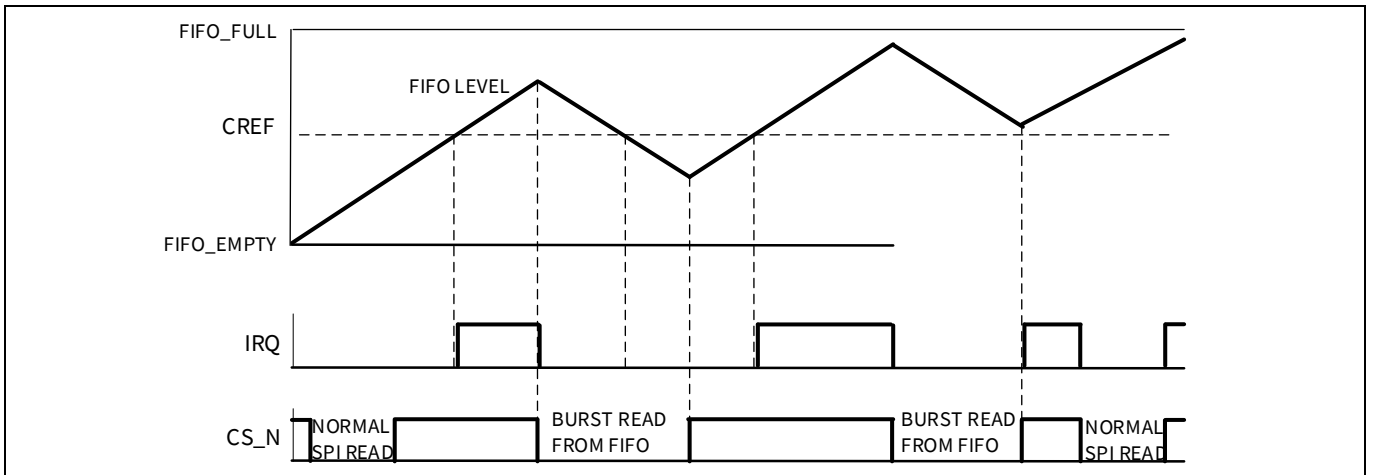

**Figure 78 IRQ status behavior during radar mode with FSM capturing data**

## Example of Typical Configurations

### 11 Example of Typical Configurations

#### 11.1 Case #1

A specific use case targeting two alternating operation modes, for long range and short range, is presented. In short range mode, the sensor is expected to achieve a large resolution and transmit low power while in long range a large transmitted power associated to a lower resolution is expected. The parameters are selected also to avoid overflow as well as underflow error in the FIFO. In Figure 79 is reported an overview of the proposed case #1.

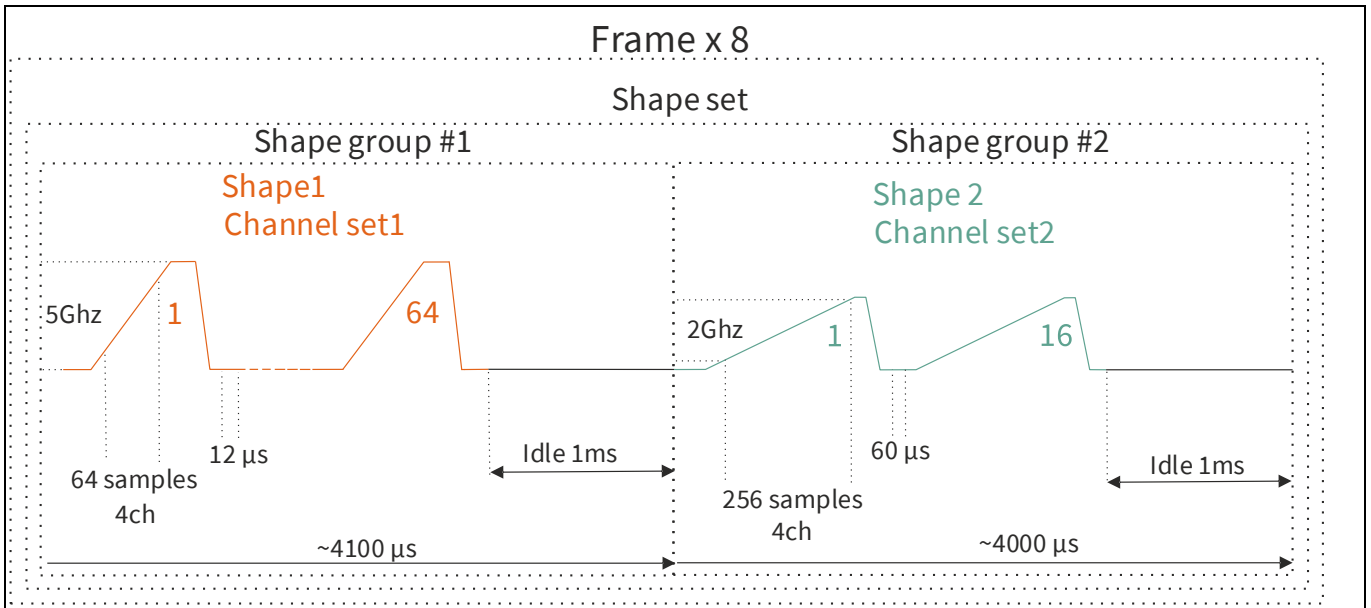

Figure 79 Case #1 definition

#### General Settings:

T_WU	= 1000 µs (see section 4.2)
T_INIT0	= 70 µs (see section 4.15)
T_INIT1	= 15 µs (see section 4.12)

#### ADC Settings in ADC0 register:

ADC_DIV	= 40 <sub>D</sub> → f <sub>ADC_SAMP</sub> = 2 MSps
TRIG_MADC	= 0 <sub>B</sub>
MSB_CTRL	= 1 <sub>B</sub>
TRACK_CFG	= 1 <sub>D</sub>
DSCAL	= 0 <sub>B</sub>
STC	= 1 <sub>B</sub>
BG_CHOP_EN	= 0 <sub>B</sub>
BG_TC_TRIM	= 0 <sub>D</sub>
ADC_OVERS_CFG	= 00

#### Frame Definition (see section 3):

## Example of Typical Configurations

<b>Frames to be run</b>	= 8	
<b>Shape set</b>	= 1 (shape set=frame in this case)	→ RT=1 → REPT=0
<b>N_SHAPE_EN</b>	= 2	
<b>FRAME_LEN</b>	= 2*1	
<b>Shape group</b>	= 2	
<b>Shape1</b>	= enabled and repeated 64 times	→ RS=64 → REPS=6
<b>Shape2</b>	= enabled and repeated 16 times	→ RS=16 → REPS=4
<b>Channel set 1</b>	= enabled	→ RC=64 → REPC=6
<b>Channel set 2</b>	= enabled	→ RC=16 → REPC=4
<b>T_SED</b>	= 1000 μs (see section 4.17)	
<b>T_EDU</b>	= 0 μs (see section 4.16)	
<b>T_EDD shape1</b>	= 12 μs (see section 4.16)	
<b>T_EDD shape2</b>	= 60 μs (see section 4.16)	

## Frequency Parameter Definition:

### Shape 1

Saw-tooth shape	→ PACR2: FSTDNEN set to 1 to 3 <sub>D</sub> (see section 4.7)
	→ PLL4:FSD set 0 <sub>B</sub>
	→ PLL5:RSD set 0 <sub>B</sub>
	→ PLL6:RTD set 0 <sub>B</sub>
Start first frequency, <b>FSU</b>	→ 58 GHz → mapped in 24 bits: 101010100000000000000000 <sub>b</sub>
Expected Bandwidth	→ 5 GHz
Nr. of samples, <b>APU</b>	→ 64
ADC sample rate, <b>f<sub>ADC_SAMP</sub></b>	→ 2 MSps
Then:	
Acquisition time, <b>T<sub>ACQUx</sub></b>	→ (APU)/ f <sub>ADC_SAMP</sub> = 31.5 μs
Ramp time, <b>T<sub>RAMP</sub></b>	→ T_PAEN + T_SSTART + T_ACQUx + T_ECM – T_START= 37.5 μs
with:	
<b>T_SSTART</b>	→ 1 μs
<b>T_PAEN</b>	→ 10 μs
<b>T_ECM</b>	→ 3 μs
<b>T_START</b>	→ 8 μs

Then:

## Example of Typical Configurations

Number of steps, <b>RTU</b>	→ 37.5 $\mu$ s/100 ns= 375
Step size, <b>RSU</b>	→ ~1.667 MHz → mapped in 24 bits: 101010101010 <sub>b</sub>
Calculated Bandwidth	→ RTU*8*RSU= 4.998779297 GHz

### Shape 2

Saw-tooth shape	→ PACR2: FSTDNEN: 1 to 3 <sub>D</sub> (see section 4.7) → PLL4:FSD set 0 <sub>B</sub> → PLL5:RSD set 0 <sub>B</sub> → PLL6:RTD set 0 <sub>B</sub>
Start first frequency, <b>FSU</b>	→ 60 GHz → mapped in 24 bits: 110111000000000000000000 <sub>b</sub>
Expected Bandwidth	→ 2 GHz
Nr. of samples, <b>APU</b>	→ 256
ADC sample rate, <b>f<sub>ADC_SAMP</sub></b>	→ 2 MSps
Then:	
Acquisition time, <b>T<sub>ACQUx</sub></b>	→ ( <b>APU</b> )/ <b>f<sub>ADC_SAMP</sub></b> = 127.5 $\mu$ s
Ramp time, <b>T<sub>RAMP</sub></b>	→ T_PAEN + T_SSTART + T_ACQUx + T_ECM – T_START= 133.5 $\mu$ s
with:	
<b>T<sub>SSTART</sub></b>	→ 1 $\mu$ s
<b>T_PAEN</b>	→ 10 $\mu$ s
<b>T_ECM</b>	→ 3 $\mu$ s
<b>T_START</b>	→ 8 $\mu$ s
Then:	
Number of steps, <b>RTU</b>	→ 133.5 $\mu$ s/100 ns= 1335
Step size, <b>RSU</b>	→ ~0.187 MHz → mapped in 24 bits: 100110010 <sub>b</sub>
Calculated Bandwidth	→ RTU*8*RSU= 1.994677734 GHz



## Example of Typical Configurations

### Channel Set Parameter Definition:

#### Channel Set 1

**Table 65 CSU1\_0 Register Settings**

Symbol	Bits	SET	Comment
TEMP_MEAS_EN	21	1 <sub>B</sub>	
BBCHGLOB_EN	20	1 <sub>B</sub>	
RX3MIX_EN	17	1 <sub>B</sub>	
RX3LOBUF_EN	16	1 <sub>B</sub>	
RX2MIX_EN	15	1 <sub>B</sub>	
RX2LOBUF_EN	14	1 <sub>B</sub>	
RX1MIX_EN	13	1 <sub>B</sub>	
RX1LOBUF_EN	12	1 <sub>B</sub>	
LO_DIST1_EN	11	1 <sub>B</sub>	
LO_DIST2_EN	10	1 <sub>B</sub>	
FDIV_EN	6	1 <sub>B</sub>	
TEST_DIV_EN	5	0 <sub>B</sub>	
VCO_EN	4	1 <sub>B</sub>	
PD1_EN	1	1 <sub>B</sub>	
TX1_EN	0	1 <sub>B</sub>	

**Table 66 CSU1\_1 Register Settings**

Symbol	Bits	SET	Comment
BBCH_SEL	23:20	0111 <sub>B</sub>	3ch ADC mode
BB_RSTCNT	19:13	101000 <sub>D</sub>	
TEMP_MEAS_EN	12	0 <sub>B</sub>	It will be removed
MADC_EN	10	1 <sub>B</sub>	
TX_DAC	4:0	00111 <sub>B</sub>	Low Tx power

**Table 67 CSU1\_2 Register Settings**

Symbol	Bits	SET	Low gain settings
HP_GAIN	23:20	0111 <sub>B</sub>	
VGA_GAIN3	14:12	0 <sub>B</sub>	
HPF_SEL3	11:10	11 <sub>B</sub>	
VGA_GAIN2	9:7	0 <sub>B</sub>	
HPF_SEL2	6:5	11 <sub>B</sub>	
VGA_GAIN1	4:2	0 <sub>B</sub>	
HPF_SEL1	1:0	11 <sub>B</sub>	

## Example of Typical Configurations

### Channel set2

**Table 68 CSU2\_0 Register Settings**

Symbol	Bits	SET	Comment
TEMP_MEAS_EN	21	1 <sub>B</sub>	
BBCHGLOB_EN	20	1 <sub>B</sub>	
RX3MIX_EN	17	1 <sub>B</sub>	
RX3LOBUF_EN	16	1 <sub>B</sub>	
RX2MIX_EN	15	1 <sub>B</sub>	
RX2LOBUF_EN	14	1 <sub>B</sub>	
RX1MIX_EN	13	1 <sub>B</sub>	
RX1LOBUF_EN	12	1 <sub>B</sub>	
LO_DIST1_EN	11	1 <sub>B</sub>	
LO_DIST2_EN	10	1 <sub>B</sub>	
FDIV_EN	6	1 <sub>B</sub>	
TEST_DIV_EN	5	0 <sub>B</sub>	
VCO_EN	4	1 <sub>B</sub>	
PD_EN	1	1 <sub>B</sub>	
TX_EN	0	1 <sub>B</sub>	

**Table 69 CSU2\_1 Register Settings**

Symbol	#Bits	SET	Comment
BBCH_SEL	23:20	1111 <sub>B</sub>	4ch ADC mode
BB_RSTCNT	19:13	101000 <sub>D</sub>	
TEMP_MEAS_EN	11	1 <sub>B</sub>	It will be removed
MADC_EN	10	1 <sub>B</sub>	
TX_DAC	4:0	11111 <sub>B</sub>	Highest Tx power

**Table 70 CSU2\_2 Register Settings**

Symbol	Bits	SET	Comment
HP_GAIN	23:20	0111 <sub>B</sub>	Highest gain settings for longest range detection
VGA_GAIN3	14:12	111 <sub>B</sub>	
HPF_SEL3	11:10	11 <sub>B</sub>	
VGA_GAIN2	9:7	111 <sub>B</sub>	
HPF_SEL2	6:5	11 <sub>B</sub>	
VGA_GAIN1	4:2	111 <sub>B</sub>	
HPF_SEL1	1:0	11 <sub>B</sub>	

## Example of Typical Configurations

### CSCx Register Settings:

**Table 71** CSCx Register Settings

CSCx Register	RST	CSC1	CSC2	CSC3	CSC4	CSCI	CSCDS
PLL_ISOPD	1	0	0	1	1	1	1
BG_TMRF_EN	0	1	1	0	0	0	0
SADC_ISOPD	1	0	0	1	1	1	1
MADC_ISOPD	1	0	0	1	1	1	1
BG_EN	0	1	1	0	0	1	0
RF_ISOPD	1	0	0	1	1	1	1
ABB_ISOPD	1	0	0	1	1	1	1
CS_EN	0	1	1	0	0	0	0
REPC	0	0	0	0	0	0	0

Package

12 Package

The BGT60TR13C chipset is housed in a laminate package with solder balls of 300 μm diameter and a standoff of 240 μm. According to IPC/JEDEC’s J-STD0, the moisture sensitivity level (MSL) is 3. Figure 80 shows the top view of BGT60TR13C package and its physical dimension. The bottom view is presented in Figure 81. The package size is 6.5 x 5 x 0.9 mm<sup>3</sup> with ball pitch of 500 μm. Package outline is reported on Figure 82. Package name: PG-VF2BGA40-1.

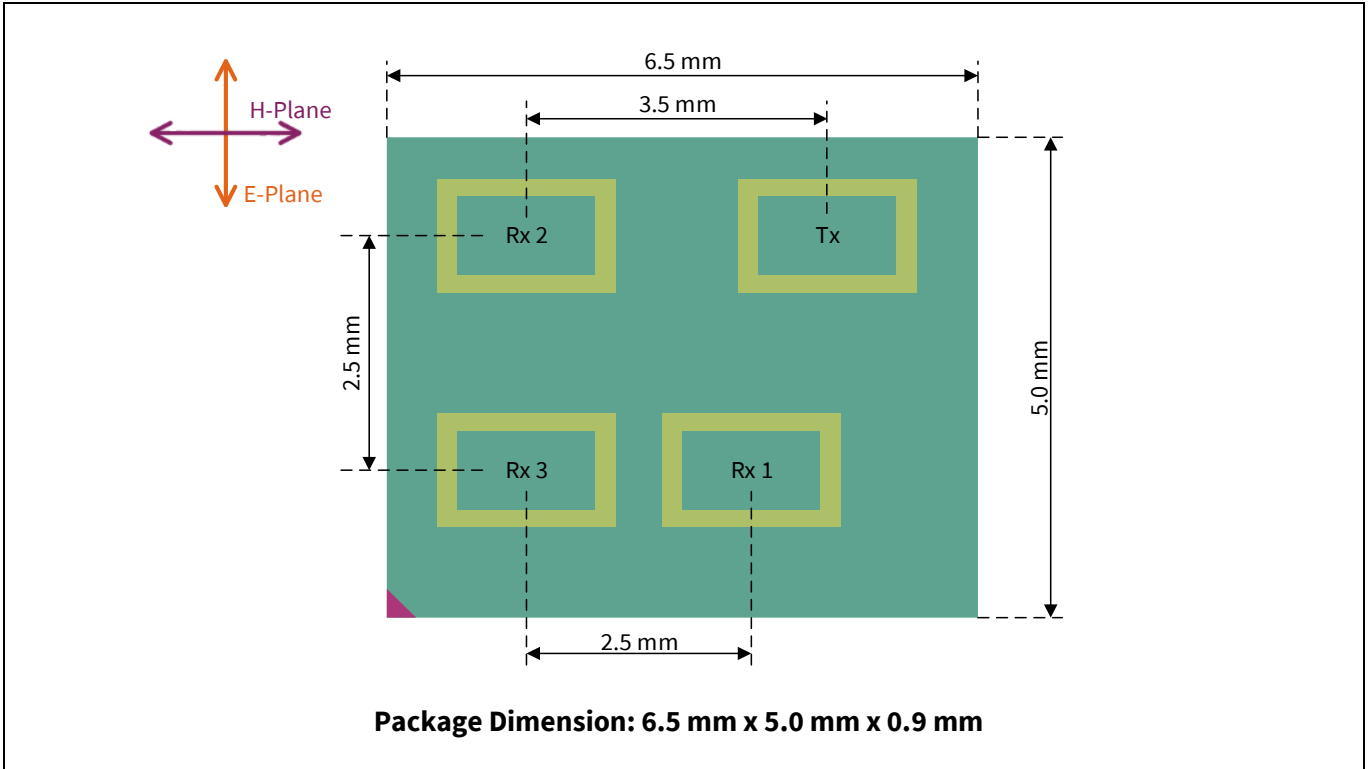

Figure 80 Top view of BGT60TR13C

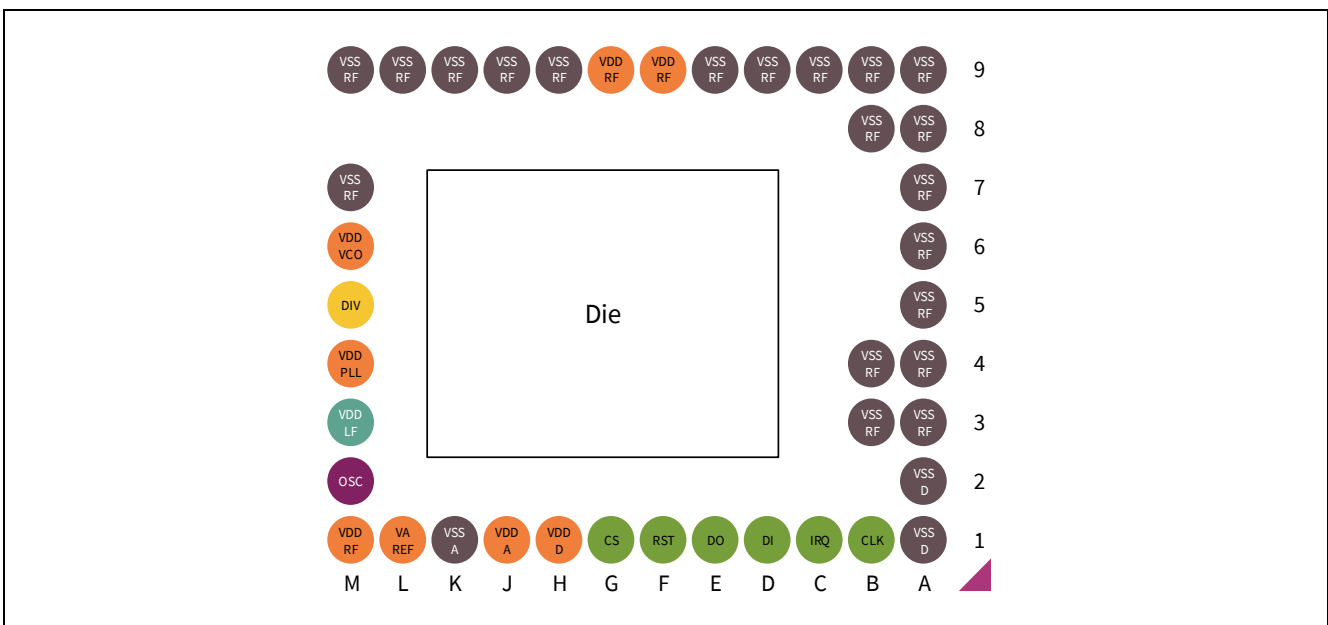

Figure 81 Bottom view of BGT60TR13C

Package

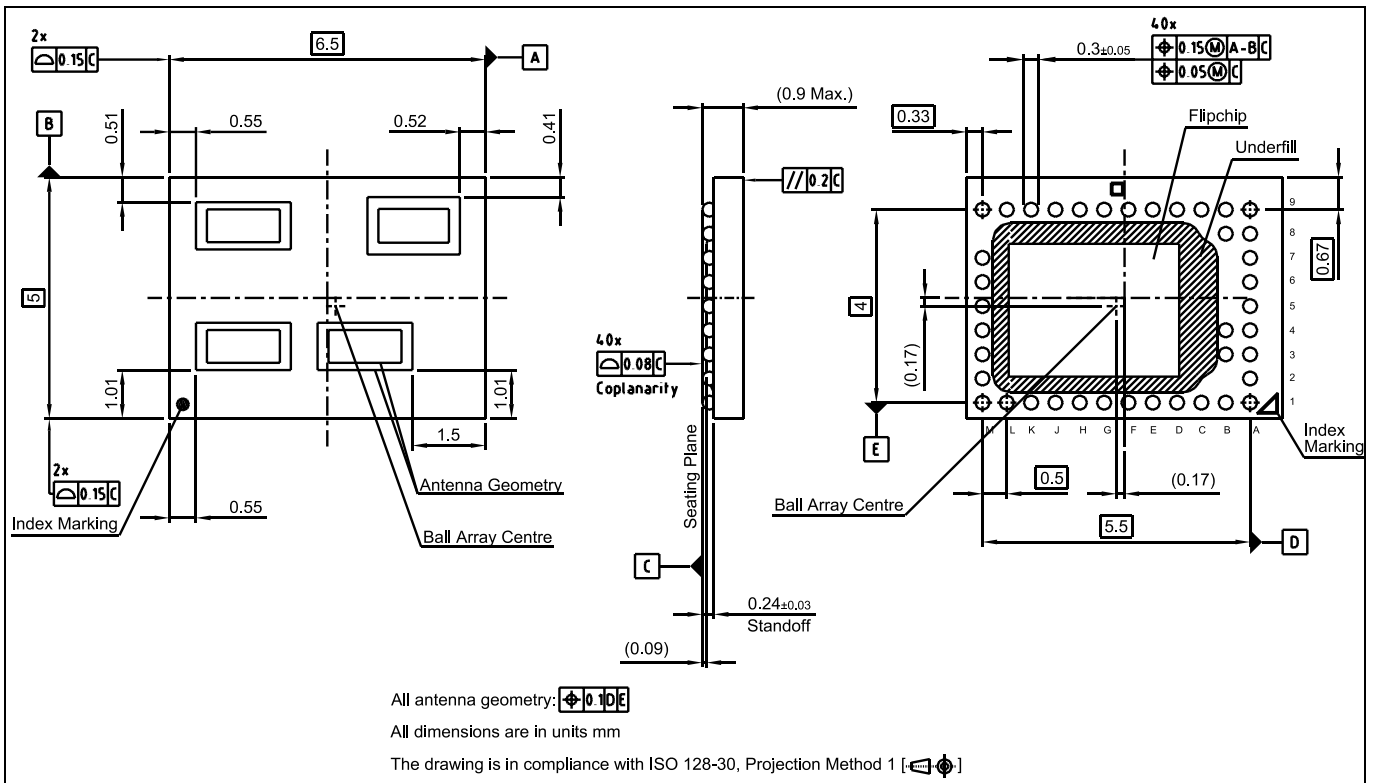

Figure 82 Package outline PG-VF2BGA-40-1

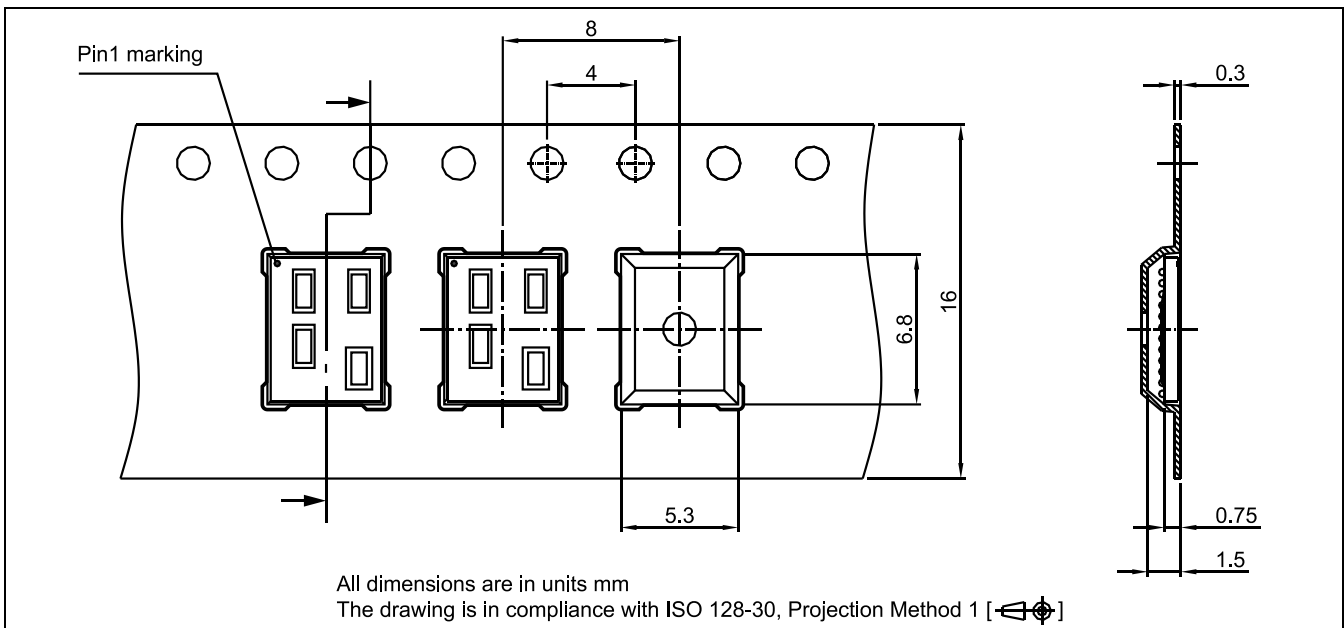

Figure 83 Tape of PG-VF2BGA-40-1

Package

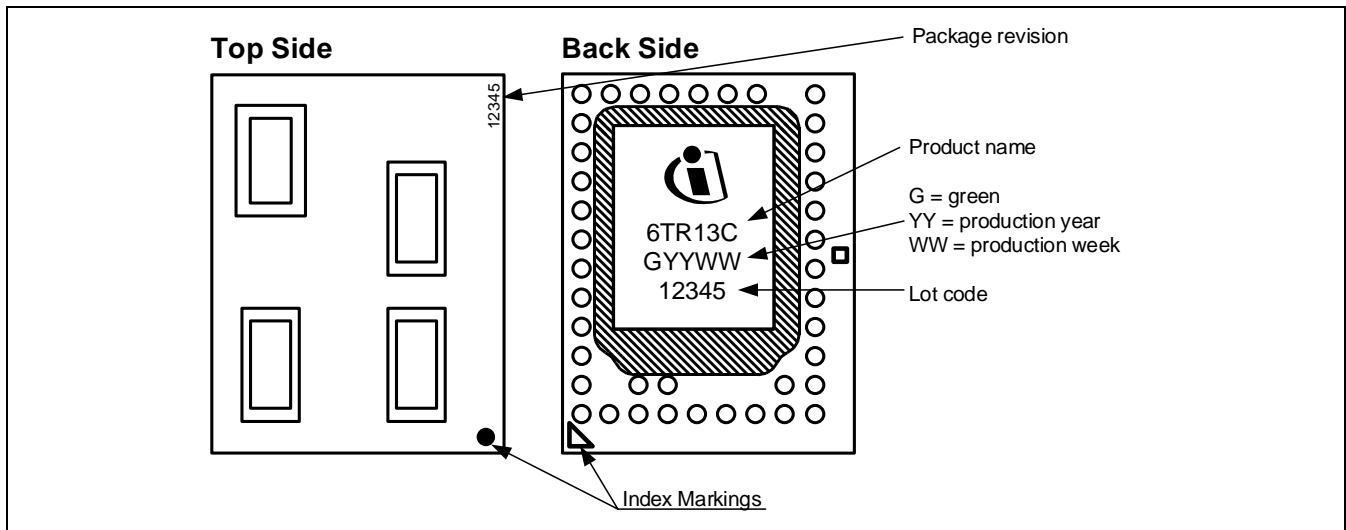

Figure 84 Marking layout of PG-VF2BGA-40-1 (example)

12.1 Built-in Antenna Specifications

Antenna performance reported in Table 72 are guaranteed by design. Typical antenna behavior is measured on Infineon reference board. Typical antenna beam plots are available in a specific application note and upon specific request.

Table 72 Antennas In Package Specifications

Spec	Unit	Value			Condition
		Min	Typ	Max	
Parameter					
RX_BW, TX_BW	GHz	58.0		63.5	Antenna bandwidth
GTX	dBi	2.0	3.5	5.0	Antenna gain of a single TX antenna
GRX	dBi	2.0	3.5	5.0	Antenna gain of a single RX antenna
HPBW_RX_E	Deg	50	65	80	Half-power beam width of a single RX antenna in the E-plane direction
HPBW_RX_H	Deg	20	35	50	Half-power beam width of a single RX antenna in the H-plane direction.
HPBW_TX_E	Deg	50	65	80	Half-power beam width of a single TX antenna in the E-plane direction
HPBW_TX_H	Deg	25	40	55	Half-power beam width of a single TX antenna in the H-plane direction
D_RX_RX	mm		2.5		Center-to-center distance between RX antennas in X and Y direction

## Abbreviations

### 13 Abbreviations

**Table 73 Abbreviations**

<b>Symbol</b>	<b>Description</b>
AAF	Anti-aliasing filter
ADC	Analog to digital converter
AP	Application Processor
DAC	Digital to analog converter
ESD	Electrostatic discharge
FMCW	Frequency modulated continuous wave
HBM	Human body model (related to ESD)
CDM	Charge device model (related to ESD)
HPF	High pass filter
IC	Integrated circuit
LPF	Low pass filter
MCU	Microcontroller Unit
PLL	Phase locked loop integrated circuit
RF	Radio Frequency
RSVD	Reserved
RX	Receiver
SPI	Serial peripheral interface
TX	Transmitter
LDO	Low dropout voltage regulator
RST	Reset or Default setting
MSB	Most significant bit
LSB	Least significant bit

## Revision History

## 14 Revision History

Document version	Date of release	Description of changes
2.4.2	2020-02-21	Updated description for FRAME_CNT in Table 24 and Table 45. Updated Figure 49 and Figure 50. Remove typo in Chapters 5.3 and 8. Changed text in Chapters 4.6 and 4.7. Changed Table 60.
2.4.3	2020-03-25	Added line for DFT0 in Table 20. Typo in package name in Chapter 12. Added Figure 83 and Figure 84 in Chapter 12. Removed remaining QSPI statements in chapters 4.8 and 5.8.
2.4.4	2020-05-04	Updated Min values for Table 6.
2.4.5	2020-06-23	Updated description for: <ul style="list-style-type: none"> <li>- TR_WKUP and TR_WKUP_MUL in Table 21</li> <li>- TR_INIT1 and TR_INIT1_MUL in Table 33</li> <li>- TR_END in Table 33</li> <li>- TR_FED and TR_FED_MUL in Table 34</li> <li>- TR_START in Table 34</li> <li>- TR_INIT0 and TR_INIT0_MUL in Table 36</li> <li>- TR_SSTART in Table 36</li> <li>- FSU and FSD in Table 37</li> <li>- TR_EDD in Table 37</li> <li>- TR_SED and TR_SED_MUL in Table 38</li> </ul>
2.4.6	2021-01-08	Update paragraph 4.2 and 5.3. Added paragraphs 5.4 and 5.5. Updated Table 26, 27, 30, 32, 40, 41 and corresponding Figures.
2.4.7	2023-01-08	Updated T_INIT0 and T_INIT1 in Table 15. Updated Note 3 of CCR3 register. Updated T <sub>WUADC</sub> in Table 61. Updated input capacitance. Added Typ. and removed Min. values Table 48.
2.4.8	2023-06-06	Updated “CW Mode” trigger5 and trigger6.
2.4.9	2023-11-21	Removed output slewrates from input pad timing Table 48. Fixed several typos.



## Trademarks

All referenced product or service names and trademarks are the property of their respective owners.

**Edition 2023-11-03**

**Published by**

**Infineon Technologies AG**

**81726 Munich, Germany**

**© 2023 Infineon Technologies AG.  
All Rights Reserved.**

**Do you have a question about this document?**

**Email:**

[erratum@infineon.com](mailto:erratum@infineon.com)

### IMPORTANT NOTICE

The information given in this document shall in no event be regarded as a guarantee of conditions or characteristics ("Beschaffheitsgarantie").

With respect to any examples, hints or any typical values stated herein and/or any information regarding the application of the product, Infineon Technologies hereby disclaims any and all warranties and liabilities of any kind, including without limitation warranties of non-infringement of intellectual property rights of any third party.

In addition, any information given in this document is subject to customer's compliance with its obligations stated in this document and any applicable legal requirements, norms and standards concerning customer's products and any use of the product of Infineon Technologies in customer's applications.

The data contained in this document is exclusively intended for technically trained staff. It is the responsibility of customer's technical departments to evaluate the suitability of the product for the intended application and the completeness of the product information given in this document with respect to such application.

For further information on the product, technology delivery terms and conditions and prices please contact your nearest Infineon Technologies office ([www.infineon.com](http://www.infineon.com)).

### WARNINGS

Due to technical requirements products may contain dangerous substances. For information on the types in question please contact your nearest Infineon Technologies office.

Except as otherwise explicitly approved by Infineon Technologies in a written document signed by authorized representatives of Infineon Technologies, Infineon Technologies' products may not be used in any applications where a failure of the product or any consequences of the use thereof car reasonably be expected to result in personal injury.