

Product Brief

Fixed Frequency and Quasi-Resonant CoolSET™ in DSO-12 package

Infineon is extending the products portfolio with Fixed Frequency (FF) and Quasi-Resonant (QR) CoolSET™ in SMD package (DSO-12) in order to meet the increasing demand of SMD package used in PCB designs. By leveraging the CoolMOS™ technology, the new CoolSET™ are enabled to deliver high power in SMD package.

Applications

- > LCD monitor, blue ray/DVD player, set-top box
- > Auxiliary power supply in white goods, server, telecom, PC silverbox, TV, printer and audio system
- > Adapter/charger

Product summary

Topology	V _{DS} [V]	Frequency [kHz]	Sales product name	P _{OUT} [W]	R _{DS(on)} [Ω]
Quasi-Resonant flyback (QR)	800	n/a	ICE2QR4780G <i>New</i>	14	4.7
	800	n/a	ICE2QR2280G	20	2.2
	800	n/a	ICE2QR2280G(-1)	20	2.2
	800	n/a	ICE2QR1080G <i>New</i>	31	1.0
	650	n/a	ICE2QR4765G	14	4.7
	650	n/a	ICE2QR1765G	23	1.7
	650	n/a	ICE2QR0665G	38	0.6
Fixed Frequency flyback (FF)	650	67	ICE3RBR4765JG <i>New</i>	14	4.7
	650	67	ICE3RBR1765JG <i>New</i>	23	1.7
	650	67	ICE3RBR0665JG <i>New</i>	37	0.6
	800	100	ICE3AR4780JG <i>New</i>	14	4.7
	800	100	ICE3AR2280JG <i>New</i>	19	2.2
	800	100	ICE3AR1080JG <i>New</i>	30	1.0

Key features

- > 650/800 V avalanche rugged CoolMOS™ with startup cell
- > Active burst mode for lowest standby power
- > 65/100 kHz internally fixed switching frequency with jittering feature (FF)
- > Quasi-Resonant operation until very low load with digital frequency reduction (QR)
- > Cycle-by-cycle current mode control
- > Adjustable brown-in/brown-out features (FF)
- > Various protection features for robust system design

Key benefits

- > High power delivery capability in DSO-12 package
- > Smaller PCB size, slim and compact design
- > SMD package enable full automation in production
- > Robust avalanche rugged CoolMOS™ inside
- > Low standby power
- > Low EMI emission
- > High efficiency

DSO-12 CoolSET™

Fixed Frequency and Quasi-Resonant

Typical application schematic using QR/FF CoolSET™

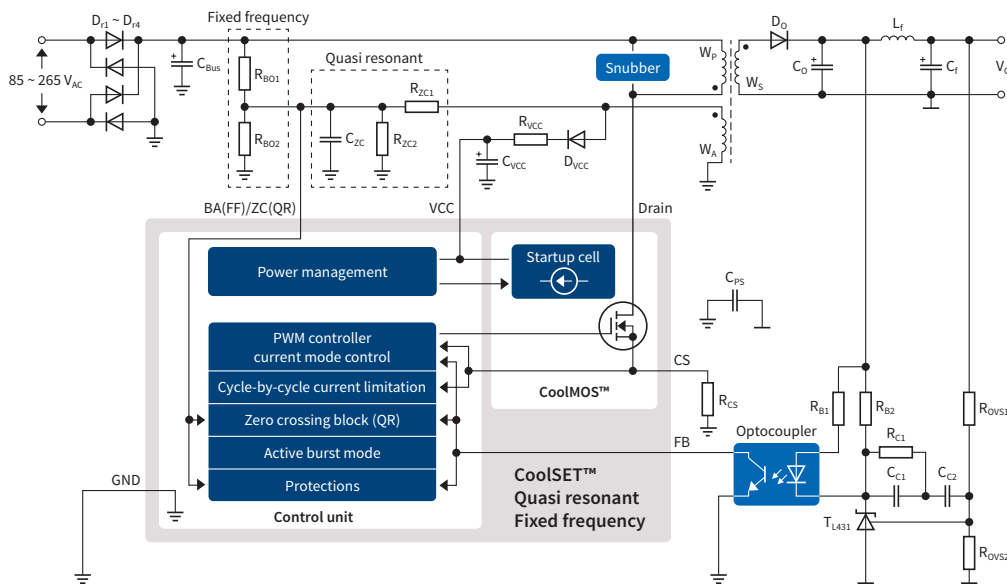

Evaluation boards



Evaluation boards – product overview

Topology	Sales product name	V_{DS} [V]	P_{OUT} [W]	V_{OUT} [V]	CoolSET™
Quasi-Resonant flyback (QR)	DEMO-2QR4780G New	800	12	12	ICE2QR4780G New
	EVAL-2QR2280G-1	800	20	5	ICE2QR2280G ICE2QR2280G-1
	DEMO-2QR1080G New	800	28	12	ICE2QR1080G New
	EVALQRC-ICE2QR4765G	650	10	5	ICE2QR4765G
	EVAL-2QR1765G-18W	650	18	5	ICE2QR1765G
	EVAL-2QR0665G-28W 16V	650	28	16	ICE2QR0665G
Fixed Frequency flyback (FF)	DEMO-3RBR4765JG New	650	12	12	ICE3RBR4765JG New
	DEMO-3RBR1765JG New	650	20	12	ICE3RBR1765JG New
	DEMO-3RBR0665JG New	650	30	12	ICE3RBR0665JG New
	DEMO-3AR4780JG New	800	12	12	ICE3AR4780JG New
	DEMO-3AR2280JG New	800	18	12	ICE3AR2280JG New
	DEMO-3AR1080JG New	800	28	12	ICE3AR1080JG New

Published by
Infineon Technologies AG
81726 Munich, Germany

© 2016 Infineon Technologies AG.
All Rights Reserved.

Please note!

THIS DOCUMENT IS FOR INFORMATION PURPOSES ONLY AND ANY INFORMATION GIVEN HEREIN SHALL IN NO EVENT BE REGARDED AS A WARRANTY, GUARANTEE OR DESCRIPTION OF ANY FUNCTIONALITY, CONDITIONS AND/OR QUALITY OF OUR PRODUCTS OR ANY SUITABILITY FOR A PARTICULAR PURPOSE. WITH REGARD TO THE TECHNICAL SPECIFICATIONS OF OUR PRODUCTS, WE KINDLY ASK YOU TO REFER TO THE RELEVANT PRODUCT DATA SHEETS PROVIDED BY US. OUR CUSTOMERS AND THEIR TECHNICAL DEPARTMENTS ARE REQUIRED TO EVALUATE THE SUITABILITY OF OUR PRODUCTS FOR THE INTENDED APPLICATION.

WE RESERVE THE RIGHT TO CHANGE THIS DOCUMENT AND/OR THE INFORMATION GIVEN HEREIN AT ANY TIME.

Additional information

For further information on technologies, our products, the application of our products, delivery terms and conditions and/or prices, please contact your nearest Infineon Technologies office (www.infineon.com).

Warnings

Due to technical requirements, our products may contain dangerous substances. For information on the types in question, please contact your nearest Infineon Technologies office.

Except as otherwise explicitly approved by us in a written document signed by authorized representatives of Infineon Technologies, our products may not be used in any life-endangering applications, including but not limited to medical, nuclear, military, life-critical or any other applications where a failure of the product or any consequences of the use thereof can result in personal injury.