

I2C Master/Multi-Master/Slave

3.30

Features

- Industry-standard NXP® I²C bus interface
- Supports slave, master, multi-master and multi-master-slave operation
- Requires only two pins (SDA and SCL) to interface to I²C bus
- Supports standard data rates of 100/400/1000 kbps
- High-level APIs require minimal user programming

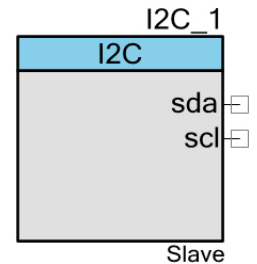

General Description

The I²C component supports I²C slave, master, and multi-master configurations. The I²C bus is an industry-standard, two-wire hardware interface developed by Philips. The master initiates all communication on the I²C bus and supplies the clock for all slave devices.

The I²C component supports standard clock speeds up to 1000 kbps. It is compatible¹ with I²C Standard-mode, Fast-mode, and Fast-mode Plus devices as defined in the NXP I²C-bus specification. The I²C component is compatible with other third-party slave and master devices.

Note This version of the component datasheet covers both the fixed hardware I²C block and the UDB version.

¹ The I²C peripheral is non-compliant with the NXP I²C specification in the following areas: analog glitch filter, I/O V_{OL}/I_{OL}, I/O hysteresis. The I²C Block has a digital glitch filter (not available in sleep mode). The Fast-mode minimum fall-time specification can be met by setting the I/Os to slow speed mode. See the I/O Electrical Specifications in "Inputs and Outputs" section of device datasheet for details.

When to Use an I²C Component

The I²C component is an ideal solution when networking multiple devices on a single board or small system. The system can be designed with a single master and multiple slaves, multiple masters, or a combination of masters and slaves.

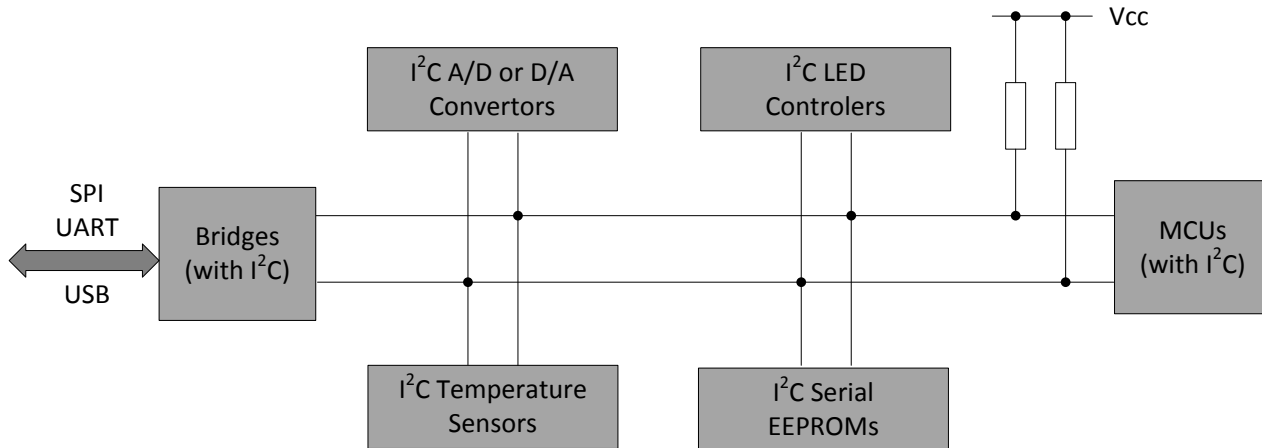

Input/Output Connections

This section describes the various input and output connections for the I²C component. An asterisk (*) in the list of I/Os indicates that the I/O may be hidden on the symbol under the conditions listed in the description of that I/O.

sda – In/Out

Serial data (SDA) is the I²C data signal. It is a bidirectional data signal used to transmit or receive all bus data. The pin connected to sda should be configured as Open-Drain-Drives-Low.

scl – In/Out

Serial clock (SCL) is the master-generated I²C clock. Although the slave never generates the clock signal, it may hold the clock low, stalling the bus until it is ready to send data or ACK/NAK² the latest data or address. The pin connected to scl should be configured as Open-Drain-Drives-Low.

² NAK is an abbreviation for negative acknowledgment or not acknowledged. I²C documents commonly use NACK while the rest of the networking world uses NAK. They mean the same thing.

clock – Input *

The clock input is available when the **Implementation** parameter is set to **UDB**. The UDB version needs a clock to provide 16 times oversampling.

Bus	Clock
50 kbps	800 kHz
100 kbps	1.6 MHz
400 kbps	6.4 MHz
1000 kbps	16 MHz

reset – Input *

The reset input is available when the **Implementation** parameter is set to **UDB**. If the reset pin is held to logic high, the I²C block is held in reset, and communication over I²C stops. This is a hardware reset only. Software must be independently reset using the I2C_Stop() and I2C_Start() APIs. The reset input may be left floating with no external connection. If nothing is connected to the reset line, the component will assign it a constant logic 0.

I²C Bus Multiplexing

The following inputs and outputs are only available when the **External OE buffer** option is selected (on the **Advanced** tab). The internal OE buffers are removed and bidirectional scl and sda terminals are replaced with separate sda_i and scl_i inputs as well as sda_o and scl_o outputs. This allows internal I²C bus multiplexing.

sda_i – Input *

Serial data input signal used to receive data. The sda_i terminal should be connected to a tri-state buffer feedback signal for an SDA bidirectional pin.

scl_i – Input *

Serial clock input clock signal used to receive clocks in slave mode and handle clock synchronization in master mode. The scl_i terminal should be connected to a tri-state buffer feedback signal for an SCL bidirectional pin.

sda_o – Output *

Serial data output signal used to transmit data. The sda_o terminal should be connected to a tri-state buffer direct input signal for an SDA bidirectional pin.



scl_o – Output *

Serial clock output signal used by a slave or master to hold the clock line low, stalling the bus until it is ready for operation. The scl_o terminal should be connected to a tri-state buffer direct input signal for an SCL bidirectional pin.

Schematic Macro Information

By default, the PSoC Creator Component Catalog contains four schematic macro implementations for the I²C component. These macros contain already connected and configured pins and provide a clock source, as needed. The schematic macros use I²C Slave and Master components, configured for fixed-function and UDB hardware, as shown below.

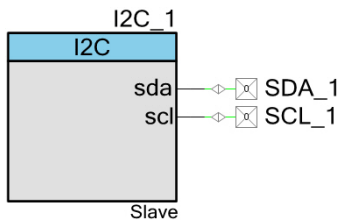
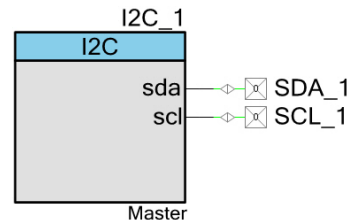
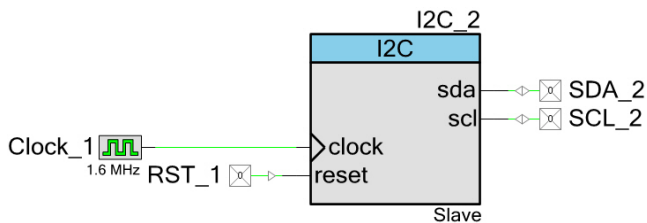
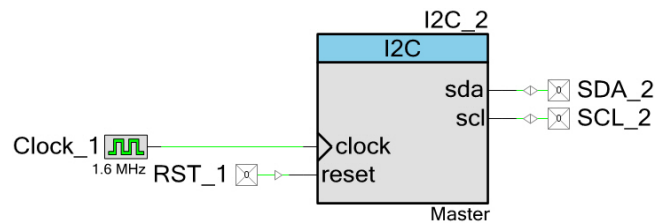
Fixed-Function I²C Slave with Pins**Fixed-Function I²C Master Pins****UDB I²C Slave with Clock and Pins****UDB I²C Master with Clock and Pins**

Component Parameters

Drag an I²C component onto your design and double-click it to open the **Configure** dialog.

Basic Configuration Tab

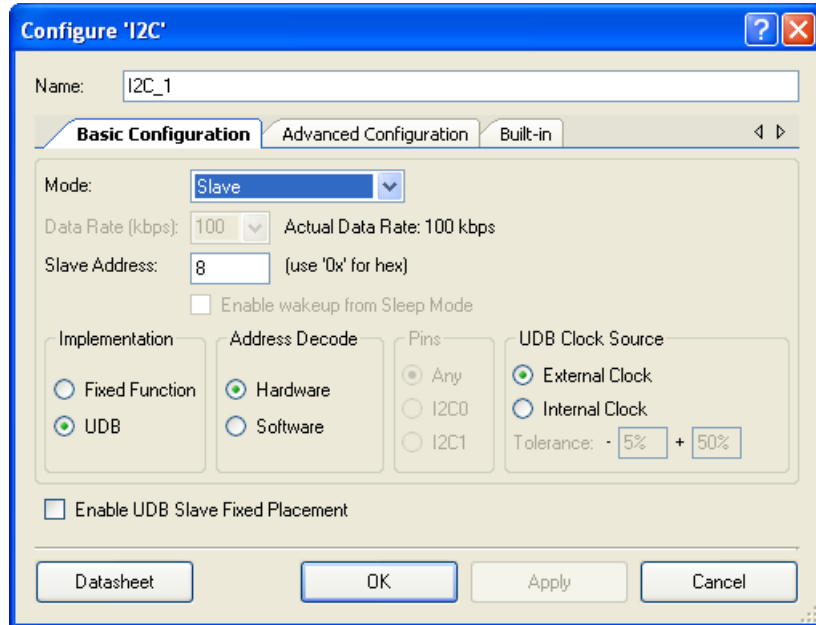

The I²C component provides the following parameters.

Mode

Use this option to select the I²C mode: slave, master, multi-master, or multi-master-slave.

Mode	Description
Slave	Slave-only operation (default).
Master	Master-only operation.
Multi-Master	Supports more than one master on the bus.
Multi-Master-Slave	Simultaneous slave and multi-master operation.

Data Rate

This parameter is used to set the I²C data rate value up to 1000 kbps; the actual speed may differ based on available clock speed and divider range. The standard data rates³ are 50, 100 (default), 400, and 1000 kbps. If **Implementation** is set to **UDB** and the **UDB Clock Source** parameter is set to **External Clock**, the **Data Rate** parameter is ignored; the 16x input clock determines the data rate.

Note If **Implementation** is set to **UDB** and the **Mode** parameter is set to **Master**, **Multi-Master**, or **Multi-Master-Slave**, the real master speed for **Data Rate** above 400 kbps may differ depending on the **BUS_CLK** value, rise and fall times of f_{SCL} ⁴, and component placement.

Slave Address

This is the I²C address that will be recognized by the slave. If slave operation is not selected, this parameter is ignored. You can select a slave address between 0 and 127 (0x00 and 0x7F); the default is **8**. This address is the 7-bit right-justified slave address and does not include the R/W bit. You can enter the value as decimal or hexadecimal; for hexadecimal numbers type '0x' before the address. If a 10-bit slave address is required, you must use software address decoding and provide decode support for the second byte of the 10-bit address in the ISR.

Implementation

This option determines how the I²C hardware is implemented on the device.

Implementation	Description
Fixed Function	Use the fixed-function block on the device (default).
UDB	Implement the I ² C in the UDB array.

Address Decode

This parameter allows you to choose between software and hardware address decoding. For most applications where the provided APIs are sufficient and only one slave address is required, hardware address decoding is preferred. In applications where you prefer to modify the source code to provide detection of multiple slave addresses or 10-bit addresses, you must use software address detection. **Hardware** is the default. If hardware address decode is enabled, the block automatically NAKs addresses that are not its own without CPU intervention. It automatically interrupts the CPU on correct address reception, and holds the SCL line low until CPU intervention.

³ Fixed-function implementation supports only standard data rates 50, 100 or 400 kbps for PSoC 5 devices. The UDB-based implementation should be used instead for different data rates up to 1000 kbps.

⁴ Refer to the *I²C-Bus Specification (Rev. 3 from June 2007)*, section 7.2.1 *Reduced f_{SCL}* .

Pins

This parameter determines which type of pins to use for SDA and SCL signal connections. There are three possible values: **Any**, **I2C0**, and **I2C1**. The default is **Any**.

Value	Pins
Any	Any GPIO or SIO pins through schematic routing
I2C0	SCL = SIO pin P12[4], SDA = SIO pin P12[5]
I2C1	SCL = SIO pin P12[0], SDA = SIO pin P12[1]

Any means general-purpose I/O (GPIO or SIO). If **Enable wakeup from Sleep Mode** is not required, use **Any** for SDA and SCL. If **Enable wakeup from Sleep Mode** is required, use **I2C0** or **I2C1**; using either **I2C0** or **I2C1** allows you to configure the device for wakeup on I²C address match.

The I²C component does not check the correct pin assignments.

Enable wakeup from Sleep Mode

This option allows the system to be awakened from sleep when an address match occurs. This option is only valid if **Address Decode** is set to **Hardware** and the SDA and SCL signals are connected to SIO pins (**I2C0** or **I2C1**). The option is disabled by default. This option is supported by the PSoC 3 and PSoC 5LP devices.

You must enable the possibility for the I²C to wake up the device on slave address match while switching to the sleep mode. You can do this by calling the I2C_Sleep() API; also refer to the [Wakeup on Hardware Address Match](#) section and to the “Power Management APIs” section of the *System Reference Guide*.

UDB Clock Source

This parameter allows you to choose between an internally configured clock and an externally configured clock for data rate generation. When set to **Internal Clock**, PSoC Creator calculates and configures the required clock frequency based on the **Data Rate** parameter, taking into account 16 times oversampling. In **External Clock** mode the component does not control the data rate but displays the actual data rate based on the user-connected clock source. If this parameter is set to **Internal Clock** then the clock input is not visible on the symbol.

You can enter the desired tolerance values for the internal clock. Clock tolerances are specified as a percentage. The default range for slave mode is **-5% to +50%**. The clock can be fast in this mode. For the remaining modes, the default range is **-25% to +5%**. Again, the master can be slow. At the maximum data rate (1000 kbps), the clock should be equal or slower, but not faster than expected. This could cause unexpected behavior.



Enable UDB Slave Fixed Placement

This parameter allows you to choose a fixed component placement that improves the component performance over unconstrained placement. If this parameter is set, all of the component resources are fixed in the top right corner of the device. This parameter controls the assignment of pins connected to the component. The choice of pin assignment is not a determining factor for component performance. This option is only valid if **Mode** is set to **Slave** and **Implementation** is set to **UDB**. This option is disabled by default.

The fixed placement aspect of the component removes the routing variability. It also allows the fixed placement to continue to operate the same as a non-fixed placed design would in a fairly empty design.

Advanced Configuration Tab

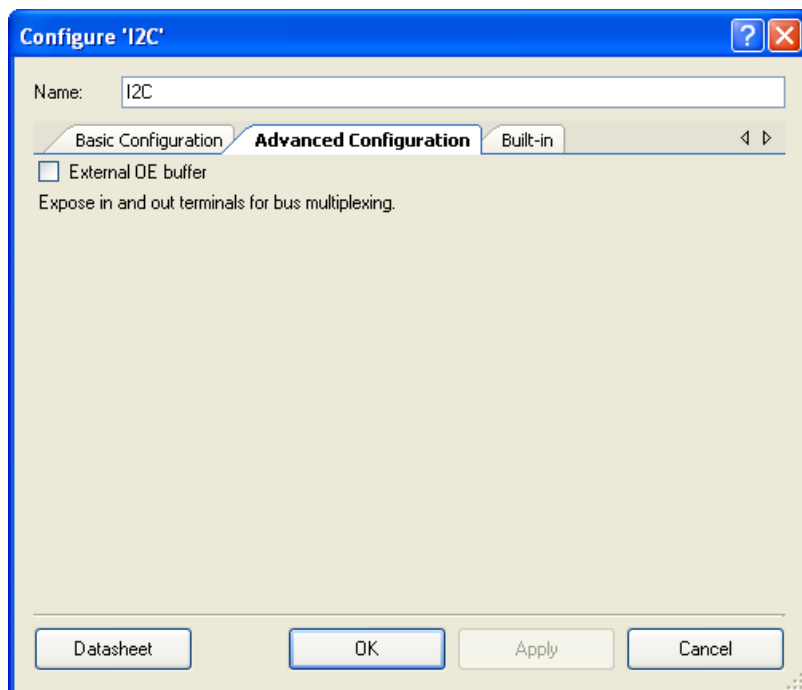

External OE buffer

This parameter allows internal I²C bus multiplexing. The internal OE buffer is removed and bidirectional scl and sda terminals are replaced with separate inputs (sda_i and scl_i) and outputs (sda_o and scl_o).

Clock Selection

When the internal clock configuration is selected, PSoC Creator calculates the needed frequency and clock source and generates the resource for implementation. Otherwise, you must supply the clock component and calculate the required clock frequency. That frequency is 16x the desired data rate available. For example, a 1.6-MHz clock is required for a 100-kbps data rate.

The fixed-function block uses BUS_CLK, which is calculated by the customizer divider to archive the 16/32 oversampling rate (50-kbps oversampling rate is 32, all other rates are 16).

Application Programming Interface

Application Programming Interface (API) routines allow you to configure the component during run time. The following table lists and describes the interface to each function. The subsequent sections discuss each function in more detail.

By default, PSoC Creator assigns the instance name “I2C_1” to the first instance of a component in a given design. You can rename the instance to any unique value that follows the syntactic rules for identifiers. The instance name becomes the prefix of every global function name, variable, and constant symbol. For readability, the instance name used in the following table is “I2C.”

All API functions assume that data direction is from the perspective of the I²C master. A write event occurs when data is written from the master to the slave. A read event occurs when the master reads data from the slave.

Generic Functions

This section includes the functions that are generic to I²C slave or master operation.

Function	Description
I2C_Start()	Initializes and enables the I ² C component. The I ² C interrupt is enabled, and the component can respond to I ² C traffic.
I2C_Stop()	Stops responding to I ² C traffic (disables the I ² C interrupt).
I2C_EnableInt()	Enables interrupt, which is required for most I ² C operations.
I2C_DisableInt()	Disables interrupt. The I2C_Stop() API does this automatically.
I2C_Sleep()	Stops I ² C operation and saves I ² C nonretention configuration registers (disables the interrupt). Prepares wake on address match operation if Wakeup from Sleep Mode is enabled (disables the I ² C interrupt).
I2C_Wakeup()	Restores I ² C nonretention configuration registers and enables I ² C operation (enables the I ² C interrupt).
I2C_Init()	Initializes I ² C registers with initial values provided from the customizer.
I2C_Enable()	Activates I ² C hardware and begins component operation.



Function	Description
I2C_SaveConfig()	Saves I ² C nonretention configuration registers (disables the I ² C interrupt).
I2C_RestoreConfig()	Restores I ² C nonretention configuration registers saved by I2C_SaveConfig() or I2C_Sleep() (enables the I ² C interrupt).

Global Variables

Knowledge of these variables is not required for normal operations.

Variable	Description
I2C_initVar	I2C_initVar indicates whether the I ² C component has been initialized. The variable is initialized to 0 and set to 1 the first time I2C_Start() is called. This allows the component to restart without reinitialization after the first call to the I2C_Start() routine. If reinitialization of the component is required, then the I2C_Init() function can be called before the I2C_Start() or I2C_Enable() function.
I2C_state	Current state of the I ² C state machine.
I2C_mstrStatus	Current status of the I ² C master.
I2C_mstrControl	Controls the master end of the transaction with or without generating a Stop.
I2C_mstrRdBufPtr	Pointer to the master read buffer.
I2C_mstrRdBufSize	Size of the master read buffer.
I2C_mstrRdBufIndex	Current index within the master read buffer.
I2C_mstrWrBufPtr	Pointer to the master write buffer.
I2C_mstrWrBufSize	Size of the master write buffer.
I2C_mstrWrBufIndex	Current index within the master write buffer.
I2C_slStatus	Current status of the I ² C slave.
I2C_slAddress	Software address of the I ² C slave.
I2C_slRdBufPtr	Pointer to the slave read buffer.
I2C_slRdBufSize	Size of the slave read buffer.
I2C_slRdBufIndex	Current index within the slave read buffer.
I2C_slWrBufPtr	Pointer to the slave write buffer.
I2C_slWrBufSize	Size of the slave write buffer.
I2C_slWrBufIndex	Current index within the slave write buffer.

Generic Functions

void I2C_Start(void)

Description: This is the preferred method to begin component operation. I2C_Start() calls the I2C_Init() function, and then calls the I2C_Enable() function. I2C_Start() must be called before I²C bus operation.

This API enables the I²C interrupt. Interrupts are required for most I²C operations.

You must set up the I²C Slave buffers before this function call to avoid reading or writing partial data while the buffers are setting up.

I²C slave behavior is as follows when enabled and buffers are not set up:

I²C Read transfer – Returns 0xFF until the read buffer is set up. Use the I2C_SlaveInitReadBuf() function to set up the read buffer;

I²C Write transfer – Send NAK because there is no place to store received data. Use the I2C_SlaveInitWriteBuf() function to set up the read buffer;

Parameters: None

Return Value: None

Side Effects: None

void I2C_Stop(void)

Description: This function disables I²C hardware and interrupt.

FF implementation(**PSoC 3 and PSoC5 LP**): Releases the I²C bus if it was locked up by the device and sets it to the idle state.

UDB implementation: Releases the I²C bus if it was locked up by the device and sets it to the idle state.

Parameters: None

Return Value: None

Side Effects: None

void I2C_EnableInt(void)

Description: This function enables the I²C interrupt. Interrupts are required for most operations.

Parameters: None

Return Value: None

Side Effects: None



void I2C_DisableInt(void)

- Description:** This function disables the I²C interrupt. This function is not normally required because the I2C_Stop() function disables the interrupt.
- Parameters:** None
- Return Value:** None
- Side Effects:** If the I²C interrupt is disabled while the I²C is still running, it can cause the I²C bus to lock up.

void I2C_Sleep(void)

- Description:** This is the preferred API to prepare the component for sleep.
- Wake up on address match enabled:** If a transaction intended for this device executes during this API call, it waits until the current transaction is completed. All subsequent I²C traffic intended for this device is NAKed until the device is put to sleep. The address match event wakes up the chip.
- Wake up on address match disabled:** This API checks current I²C component state, saves it, and disables the component by calling I2C_Stop() if it is currently enabled. I2C_SaveConfig() is then called to save the I²C nonretention configuration registers. Call the I2C_Sleep() function before calling the CyPmSleep() or the CyPmHibernate() function. See the PSoC Creator *System Reference Guide* for more information about power-management functions.
- Parameters:** None
- Return Value:** None
- Side Effects:** None

void I2C_Wakeup(void)

- Description:** This is the preferred API to restore the component to the state when I2C_Sleep() was last called. **Wake up on address match enabled:** This API enables I²C master functionality if it was enabled before sleep, and disables the I²C backup regulator. The incoming transaction continues as soon as the regular I²C interrupt handler is set.
- Wake up on address match disabled:** This API restores the I²C nonretention configuration registers by calling I2C_RestoreConfig(). If the component was enabled before the I2C_Sleep() function was called, I2C_Wakeup() re-enables it.
- Parameters:** None
- Return Value:** None
- Side Effects:** Calling the I2C_Wakeup() function without first calling the I2C_Sleep() or I2C_SaveConfig() function can produce unexpected behavior.



void I2C_Init(void)

- Description:** This function initializes or restores the component according to the customizer Configure dialog settings. It is not necessary to call I2C_Init() because the I2C_Start() API calls this function, which is the preferred method to begin component operation.
- Parameters:** None
- Return Value:** None
- Side Effects:** All registers will be set to values according to the customizer Configure dialog.

void I2C_Enable(void)

- Description:** This function activates the hardware and begins component operation. It is not necessary to call I2C_Enable() because the I2C_Start() API calls this function, which is the preferred method to begin component operation. If this API is called, I2C_Start() or I2C_Init() must be called first.
- Parameters:** None
- Return Value:** None
- Side Effects:** None

void I2C_SaveConfig(void)

- Description:** This function saves the I²C component nonretention configuration registers.
- Wakeup on address match enabled:** This API disables the I²C master, if it was enabled before, and enables the I²C backup regulator. If a transaction intended for this device executes during this API call, it waits until the current transaction is completed and I²C is ready to go to sleep. All subsequent I²C traffic is NAKed until the device is put to sleep.
- Wakeup on address match disabled:** Refer to the main description.
- Parameters:** None
- Return Value:** None
- Side Effects:** None



void I2C_RestoreConfig(void)

Description: This function restores the I²C component nonretention configuration registers to the state they were in before I2C_Sleep() or I2C_SaveConfig() was called.

Wakeup on address match enabled: This API enables I²C master functionality, if it was enabled before, and disables the I²C backup regulator. Generates the I²C interrupt if I²C was wake up source to release the bus and handles in-coming I²C transaction.

Wakeup on address match disabled: Refer to the main description.

Parameters: None

Return Value: None

Side Effects: Calling this function without first calling the I2C_Sleep() or I2C_SaveConfig() function can produce unexpected behavior.

Slave Functions

This section lists the functions that are used for I²C slave operation. These functions are available if slave operation is enabled.

Function	Description
I2C_SlaveStatus()	Returns the slave status flags.
I2C_SlaveClearReadStatus()	Returns the read status flags and clears the slave read status flags.
I2C_SlaveClearWriteStatus()	Returns the write status and clears the slave write status flags.
I2C_SlaveSetAddress()	Sets the slave address, a value between 0 and 127 (0x00 to 0x7F).
I2C_SlaveInitReadBuf()	Sets up the slave receive data buffer. (master <- slave)
I2C_SlaveInitWriteBuf()	Sets up the slave write buffer. (master -> slave)
I2C_SlaveGetReadBufSize()	Returns the number of bytes read by the master since the buffer was reset.
I2C_SlaveGetWriteBufSize()	Returns the number of bytes written by the master since the buffer was reset.
I2C_SlaveClearReadBuf()	Resets the read buffer counter to zero.
I2C_SlaveClearWriteBuf()	Resets the write buffer counter to zero.

uint8 I2C_SlaveStatus(void)

Description: This function returns the slave's communication status.

Parameters: None

Return Value: uint8: Current status of I²C slave. This status incorporates read and write status flags. Each constant is a bit field value. The value returned may have multiple bits set to indicate the status of the read or write transfer.

Slave Status Constants	Description
I2C_SSTAT_RD_CMPLT ⁵	Slave read transfer complete. Set when the master sends a NAK to say that it is done reading.
I2C_SSTAT_RD_BUSY	Slave read transfer in progress. Set when the master addresses the slave with a read, cleared when RD_CMPLT is set.
I2C_SSTAT_RD_ERR_OVFL	The master attempted to read more bytes than are in the buffer.
I2C_SSTAT_WR_CMPLT ⁶	Slave write transfer complete. Set when a Stop condition is received.
I2C_SSTAT_WR_BUSY	Slave write transfer in progress. Set when the master addresses the slave with a write and cleared when WR_CMPLT is set.
I2C_SSTAT_WR_ERR_OVFL	The master attempted to write past the end of the buffer. The incoming byte is NAKed by the slave.

Side Effects: None

uint8 I2C_SlaveClearReadStatus(void)

Description: This function clears the read status flags and returns their values. The I2C_SSTAT_RD_BUSY flag is not affected by this function call.

Parameters: None

Return Value: uint8: Current read status of the I²C slave. See the I2C_SlaveStatus() function for constants.

Side Effects: None

⁵ The definition was changed from I2C_SSTAT_RD_CMPT to I2C_SSTAT_RD_CMPLT to comply with the master read complete definition. The component supports both definitions , but the I2C_SSTAT_RD_CMPT will become obsolete.

⁶ The definition was changed from I2C_SSTAT_WR_CMPT to I2C_SSTAT_WR_CMPLT to comply with the master write complete definition. The component supports both definitions , but the I2C_SSTAT_WR_CMPT will become obsolete.

uint8 I2C_SlaveClearWriteStatus(void)

- Description:** This function clears the write status flags and returns their values. The I2C_SSTAT_WR_BUSY flag is not affected by this function call.
- Parameters:** None
- Return Value:** uint8: Current write status of the I²C slave. See the I2C_SlaveStatus() function for constants.
- Side Effects:** None

void I2C_SlaveSetAddress(uint8 address)

- Description:** This function sets the I²C slave address
- Parameters:** uint8 address: I²C slave address for the primary device. This value can be any address between 0 and 127 (0x00 to 0x7F). This address is the 7-bit right-justified slave address and does not include the R/W bit.
- Return Value:** None
- Side Effects:** None

void I2C_SlaveInitReadBuf(uint8 * rdBuf, uint8 bufSize)

- Description:** This function sets the buffer pointer and size of the read buffer. This function also resets the transfer count returned with the I2C_SlaveGetReadBufSize() function.
- Parameters:** uint8* rdBuf: Pointer to the data buffer to be read by the master.
uint8 bufSize: Size of the buffer exposed to the I²C master.
- Return Value:** None
- Side Effects:** If this function is called during a bus transaction, data from the previous buffer location and the beginning of the current buffer may be transmitted.

void I2C_SlaveInitWriteBuf(uint8 * wrBuf, uint8 bufSize)

- Description:** This function sets the buffer pointer and size of the write buffer. This function also resets the transfer count returned with the I2C_SlaveGetWriteBufSize() function.
- Parameters:** uint8* wrBuf: Pointer to the data buffer to be written by the master.
uint8 bufSize: Size of the write buffer exposed to the I²C master.
- Return Value:** None
- Side Effects:** If this function is called during a bus transaction, data may be received in the previous buffer and the current buffer location.



uint8 I2C_SlaveGetReadBufSize(void)

Description: This function returns the number of bytes read by the I²C master since an I2C_SlaveInitReadBuf() or I2C_SlaveClearReadBuf() function was executed. The maximum return value is the size of the read buffer.

Parameters: None

Return Value: uint8: Bytes read by the master.

Side Effects: None

uint8 I2C_SlaveGetWriteBufSize(void)

Description: This function returns the number of bytes written by the I²C master since an I2C_SlaveInitWriteBuf() or I2C_SlaveClearWriteBuf() function was executed. The maximum return value is the size of the write buffer.

Parameters: None

Return Value: uint8: Bytes written by the master.

Side Effects: None

void I2C_SlaveClearReadBuf(void)

Description: This function resets the read pointer to the first byte in the read buffer. The next byte the master reads will be the first byte in the read buffer.

Parameters: None

Return Value: None

Side Effects: None

void I2C_SlaveClearWriteBuf(void)

Description: This function resets the write pointer to the first byte in the write buffer. The next byte the master writes will be the first byte in the write buffer.

Parameters: None

Return Value: None

Side Effects: None



Master and Multi-Master Functions

These functions are only available if master or multi-master mode is enabled.

Function	Description
I2C_MasterStatus()	Returns the master status.
I2C_MasterClearStatus()	Returns the master status and clears the status flags.
I2C_MasterWriteBuf()	Writes the referenced data buffer to a specified slave address.
I2C_MasterReadBuf()	Reads data from the specified slave address and places the data in the referenced buffer.
I2C_MasterSendStart()	Sends only a Start to the specific address.
I2C_MasterSendRestart()	Sends only a Restart to the specified address.
I2C_MasterSendStop()	Generates a Stop condition.
I2C_MasterWriteByte()	Writes a single byte. This is a manual command that should only be used with the I2C_MasterSendStart() or I2C_MasterSendRestart() functions.
I2C_MasterReadByte()	Reads a single byte. This is a manual command that should only be used with the I2C_MasterSendStart() or I2C_MasterSendRestart() functions.
I2C_MasterGetReadBufSize()	Returns the byte count of data read since the I2C_MasterClearReadBuf() function was called.
I2C_MasterGetWriteBufSize()	Returns the byte count of the data written since the I2C_MasterClearWriteBuf() function was called.
I2C_MasterClearReadBuf()	Resets the read buffer pointer back to the beginning of the buffer.
I2C_MasterClearWriteBuf()	Resets the write buffer pointer back to the beginning of the buffer.

uint8 I2C_MasterStatus(void)

Description: This function returns the master's communication status.

Parameters: None

Return Value: uint8: Current status of the I²C master. Each constant is a bit field value. The value returned may have multiple bits set to indicate the status of the transfer along with the generation of error conditions.

Master status constants	Description
I2C_MSTAT_RD_CMPLT	Read transfer complete. The error condition bits must be checked to ensure that the read transfer was successful.
I2C_MSTAT_WR_CMPLT	Write transfer complete. The error condition bits must be checked to ensure that the write transfer was successful.
I2C_MSTAT_XFER_INP	Transfer in progress
I2C_MSTAT_XFER_HALT	Transfer has been halted. The I ² C bus is waiting for the master to generate a Restart or Stop condition.
I2C_MSTAT_ERR_SHORT_XFER	Error condition: Write transfer completed before all bytes were transferred.
I2C_MSTAT_ERR_ADDR_NAK	Error condition: The slave did not acknowledge the address.
I2C_MSTAT_ERR_ARB_LOST	Error condition: The master lost arbitration during communication with the slave.
I2C_MSTAT_ERR_XFER	Error condition: This is the ORed value of error conditions provided in this table. If all error condition bits are cleared, but this bit is set, the transfer was aborted because of slave operation.

Side Effects: None

uint8 I2C_MasterClearStatus(void)

Description: This function clears all status flags and returns the master status.

Parameters: None

Return Value: uint8: Current status of the master. See the I2C_MasterStatus() function for constants.

Side Effects: None



uint8 I2C_MasterWriteBuf(uint8 slaveAddress, uint8 * wrData, uint8 cnt, uint8 mode)

Description: This function automatically writes an entire buffer of data to a slave device. After the data transfer is initiated by this function, the included ISR manages further data transfer in byte-by-byte mode. Enables the I²C interrupt.

Parameters: uint8 slaveAddress: Right-justified 7-bit slave address (valid range 0 to 127).

uint8 wrData: Pointer to the buffer of the data to be sent.

uint8 cnt: Number of bytes of the buffer to send.

uint8 mode: Transfer mode defines: (1) Whether a Start or Restart condition is generated at the beginning of the transfer, and (2) Whether the transfer is completed or halted before the Stop condition is generated on the bus.

Transfer mode, mode constants may be ORed together.

Mode Constants	Description
I2C_MODE_COMPLETE_XFER	Perform complete transfer from Start to Stop.
I2C_MODE_REPEAT_START	Send Repeat Start instead of Start.
I2C_MODE_NO_STOP	Execute transfer without a Stop

Return Value: uint8: Error Status. See the I2C_MasterSendStart() function for constants.

Side Effects: None

uint8 I2C_MasterReadBuf(uint8 slaveAddress, uint8 * rdData, uint8 cnt, uint8 mode)

Description: This function automatically reads an entire buffer of data from a slave device. Once this function initiates the data transfer, the included ISR manages further data transfer in byte by byte mode. Enables the I²C interrupt.

Parameters: uint8 slaveAddress: Right-justified 7-bit slave address (valid range 0 to 127).

uint8 rdData: Pointer to the buffer in which to put the data from the slave.

uint8 cnt: Number of bytes of the buffer to read.

uint8 mode: Transfer mode defines: (1) Whether a Start or Restart condition is generated at the beginning of the transfer and (2) Whether the transfer is completed or halted before the Stop condition is generated on the bus.

Transfer mode, mode constants may be ORed together

Mode Constants	Description
I2C_MODE_COMPLETE_XFER	Perform complete transfer for Start to Stop.
I2C_MODE_REPEAT_START	Send Repeat Start instead of Start.
I2C_MODE_NO_STOP	Execute transfer without a Stop

Return Value: uint8: Error Status. See the I2C_MasterSendStart() function for constants.

Side Effects: None



uint8 I2C_MasterSendStart(uint8 slaveAddress, uint8 R_nW)

Description: This function generates a Start condition and sends the slave address with the read/write bit. Disables the I²C interrupt.

Parameters: uint8 slaveAddress: Right-justified 7-bit slave address (valid range 0 to 127).
uint8 R_nW: Set to zero, send write command; set to nonzero, send read command.

Return Value: uint8: Error Status.

Mode Constants	Description
I2C_MSTR_NO_ERROR	Function completed without error.
I2C_MSTR_BUS_BUSY	Bus is busy, Start condition was not generated.
I2C_MSTR_NOT_READY	The master is not a valid master on the bus, or a slave operation is in progress.
I2C_MSTR_ERR_LB_NAK	The last byte was NAKed.
I2C_MSTR_ERR_ARB_LOST	The master lost arbitration while the Start was generated. (This status is only valid if multi-master is enabled.)
I2C_MSTR_ERR_ABORT_START_GEN	Start condition generation was aborted because of the start of slave operation. (This status is only valid in multi-master-slave mode.)

Side Effects: This function is blocking and does not exit until the byte_complete bit is set in the I2C_CSR register.

uint8 I2C_MasterSendRestart(uint8 slaveAddress, uint8 R_nW)

Description: This function generates a restart condition and sends the slave address with the read/write bit.

Parameters: uint8 slaveAddress: Right-justified 7-bit slave address (valid range 0 to 127).
uint8 R_nW: Set to zero, send write command; set to nonzero, send read command.

Return Value: uint8: Error Status. See the I2C_MasterSendStart() function for constants.

Side Effects: This function is blocking and does not exit until the byte_complete bit is set in the I2C_CSR register.



uint8 I2C_MasterSendStop(void)

Description: This function generates an I²C stop condition on the bus. This function does nothing if Start or Restart conditions failed before this function was called.

Parameters: None

Return Value: uint8: Error Status. See the I2C_MasterSendStart() command for constants.

Side Effects: This function is blocking and does not exit until:

Master: This function waits while a stop condition is generated.

Multi-Master, Multi-Master-Slave: This function waits while a stop condition is generated or arbitration is lost on the ACK/NAK bit.

uint8 I2C_MasterWriteByte(uint8 theByte)

Description: This function sends one byte to a slave. A valid Start or Restart condition must be generated before calling this function. This function does nothing if the Start or Restart conditions failed before this function was called.

Parameters: uint8 theByte: Data byte to send to the slave.

Return Value: uint8: Error Status.

Mode Constants	Description
I2C_MSTR_NO_ERROR	Function complete without error.
I2C_MSTR_NOT_READY	The master is not a valid master on the bus or slave operation is in progress.
I2C_MSTR_ERR_LB_NAK	The last byte was NAKed.
I2C_MSTR_ERR_ARB_LOST	The master lost arbitration. (This status is valid only if multi-master is enabled.)

Side Effects: This function is blocking and does not exit until the byte_complete bit is set in the I2C_CSR register.

uint8 I2C_MasterReadByte(uint8 ackNak)

Description: This function reads one byte from a slave and ACKs or NAKs the transfer. A valid Start or Restart condition must be generated before calling this function. This function does nothing and returns a zero value if the Start or Restart conditions failed before this function was called.

Parameters: uint8 ackNak: If zero, sends a NAK; if nonzero sends an ACK.

Return Value: uint8: Byte read from the slave

Side Effects: This function is blocking and does not exit until the byte_complete bit is set in the I2C_CSR register



uint8 I2C_MasterGetReadBufSize(void)

- Description:** This function returns the number of bytes that have been transferred with an I2C_MasterReadBuf() function.
- Parameters:** None
- Return Value:** uint8: Byte count of the transfer. If the transfer is not yet complete, this function returns the byte count transferred so far.
- Side Effects:** None

uint8 I2C_MasterGetWriteBufSize(void)

- Description:** This function returns the number of bytes that have been transferred with an I2C_MasterWriteBuf() function.
- Parameters:** None
- Return Value:** uint8: Byte count of the transfer. If the transfer is not yet complete, this function returns the byte count transferred so far.
- Side Effects:** None

void I2C_MasterClearReadBuf (void)

- Description:** This function resets the read buffer pointer back to the first byte in the buffer.
- Parameters:** None
- Return Value:** None
- Side Effects:** None

void I2C_MasterClearWriteBuf (void)

- Description:** This function resets the write buffer pointer back to the first byte in the buffer.
- Parameters:** None
- Return Value:** None
- Side Effects:** None



Multi-Master-Slave Functions

Multi-master-slave incorporates slave and multi-master functions.

Bootloader Support

The I²C component can be used as a communication component for the Bootloader. Use the following configuration to support communication protocol from an external system to the Bootloader:

- **Mode:** Slave
- **Implementation:** Either fixed-function or UDB-based
- **Data Rate:** Must match Host (boot device) data rate.
- **Slave Address:** Must match Host (boot device) selected slave address.
- **Address Match:** Hardware is preferred but not required

For more information about the Bootloader, refer to the “Bootloader System” section of the *System Reference Guide*.

For additional information about I²C communication component implementation, refer to the [Bootloader Protocol Interaction with I2C Communication Component](#) section.

The I²C Component provides a set of API functions for Bootloader use.

Function	Description
I2C_CyBtldrCommStart	Starts the I ² C component and enables its interrupt.
I2C_CyBtldrCommStop	Disables the I ² C component and disables its interrupt.
I2C_CyBtldrCommReset	Sets read and write I ² C buffers to the initial state and resets the slave status.
I2C_CyBtldrCommRead	Allows the caller to read data from the bootloader host. This function manages polling to allow a block of data to be completely received from the host device.
I2C_CyBtldrCommWrite	Allows the caller to write data to the bootloader host. This function manages polling to allow a block of data to be completely sent to the host device.

void I2C_CyBtldrCommStart(void)

- Description:** This function starts the I²C component and enables its interrupt.
Every incoming I²C write transaction is treated as a command for the bootloader.
Every incoming I²C read transaction returns 0xFF until the bootloader provides a response to the executed command.
- Parameters:** None
- Return Value:** None
- Side Effects:** None

void I2C_CyBtldrCommStop(void)

- Description:** This function disables the I²C component and disables its interrupt.
- Parameters:** None
- Return Value:** None
- Side Effects:** None

void I2C_CyBtldrCommReset(void)

- Description:** This function sets the read and write I²C buffers to the initial state and resets the slave status.
- Parameters:** None
- Return Value:** None
- Side Effects:** None

cystatus I2C_CyBtldrCommRead(uint8 pData[], uint16 size, uint16 * count, uint8 timeOut)

- Description:** This function allows the caller to read data from the bootloader host. The function manages polling to allow a block of data to be completely received from the bootloader host.
- Parameters:** uint8 pData[]: Pointer to storage for the block of data to be read from the bootloader host
uint16 size: Number of bytes to be read
uint16 *count: Pointer to the variable to write the number of bytes actually read
uint8 timeOut: Number of units in 10 ms to wait before returning because of a timeout
- Return Value:** cystatus: Returns CYRET_SUCCESS if no problem was encountered or returns the value that best describes the problem. For more information, see the “Return Codes” section of the *System Reference Guide*.
- Side Effects:** None



cystatus I2C_CyBtldrCommWrite(const uint8 pData[], uint16 size, uint16 * count, uint8 timeOut)

- Description:** This function allows the caller to write data to the bootloader host. The function manages polling to allow a block of data to be completely sent to the bootloader host.
- Parameters:** const uint8 pData[]: Pointer to the block of data to be written to the bootloader host
 uint16 size: Number of bytes to be written
 uint16 *count: Pointer to the variable to write the number of bytes actually written
 uint8 timeOut: Number of units in 10 ms to wait before returning because of a timeout
- Return Value:** cystatus: Returns CYRET_SUCCESS if no problem was encountered or returns the value that best describes the problem. For more information see the “Return Codes” section of the *System Reference Guide*.
- Side Effects:** None

MISRA Compliance

This section describes the MISRA-C:2004 compliance and deviations for the component. There are two types of deviations defined:

- project deviations – deviations that are applicable for all PSoC Creator components
- specific deviations – deviations that are applicable only for this component

This section provides information on component-specific deviations. Project deviations are described in the MISRA Compliance section of the *System Reference Guide* along with information on the MISRA compliance verification environment.

The I²C component has the following specific deviations:

MISRA-C: 2004 Rule	Rule Class (Required/ Advisory)	Rule Description	Description of Deviation(s)
10.1	R	The value of an expression of integer type shall not be implicitly converted to a different underlying type if: <ol style="list-style-type: none"> a) it is not a conversion to a wider integer type of the same signedness, or b) the expression is complex, or c) the expression is not constant and is a function argument, or d) the expression is not constant and is a return expression 	The library function memcpy has a generic int argument for the number of bytes to be copied. An unsigned 16-bit integer is passed as an argument to this function. This action does not cause any side effects because the number of bytes to copy is always less than 256.

MISRA-C: 2004 Rule	Rule Class (Required/ Advisory)	Rule Description	Description of Deviation(s)
11.5	R	A cast shall not be performed that removes any const or volatile qualification from the type addressed by a pointer.	The library function memcpy has pointer to void arguments for the source and destination. A pointer to a constant array is passed as the source argument and the constant qualification is lost. The memcpy function implementation never changes the source and is therefore safe to use with a constant argument.
17.4	R	Array indexing shall be the only allowed form of pointer arithmetic.	The application allocates buffers and sets them up for the component providing the pointer and size. The component uses array indexing operations to access these buffers. The buffer size is checked before accessing the buffers. This implementation is safe as long as the correct buffer size is provided by the application.
19.7	A	A function should be used in preference to a function-like macro.	Deviations with function-like macros to allow for more efficient code. The component incorporates the Fixed Function and UDB implementations. Macros with arguments are used to support these two implementations in a flexible way.

This component has the following embedded component: Clock. Refer to the corresponding component datasheet for information on their MISRA compliance and specific deviations.

Sample Firmware Source Code

PSoC Creator provides many example projects that include schematics and example code in the Find Example Project dialog. For component-specific examples, open the dialog from the Component Catalog or an instance of the component in a schematic. For general examples, open the dialog from the Start Page or **File** menu. As needed, use the **Filter Options** in the dialog to narrow the list of projects available to select.

Refer to the “Find Example Project” topic in the PSoC Creator Help for more information.

Functional Description

This component supports I²C slave, master, multi-master, and multi-master-slave configurations. The following sections provide an overview of how to use the slave, master, and multi-master components.

This component requires that you enable global interrupts because the I²C hardware is interrupt driven. Although this component requires interrupts, you do not need to add any code to the ISR (interrupt service routine). The component services all interrupts (data transfers) independent of



your code. The memory buffers allocated for this interface look like simple dual-port memory between your application and the I²C master/slave.

Slave Operation

The slave interface consists of two buffers in memory, one for data written to the slave by a master and a second buffer for data read by a master from the slave. Remember that reads and writes are from the perspective of the I²C master. The I²C slave read and write buffers are set by the initialization commands below. These commands do not allocate memory, but instead copy the array pointer and size to the internal component variables. You must instantiate the arrays used for the buffers because they are not automatically generated by the component. You can use the same buffer for both read and write buffers, but you must be careful to manage the data properly.

```
void I2C_SlaveInitReadBuf(uint8 * rdBuf, uint8 bufSize)
void I2C_SlaveInitWriteBuf(uint8 * wrBuf, uint8 bufSize)
```

Using the functions above sets a pointer and byte count for the read and write buffers. The bufSize for these functions may be less than or equal to the actual array size, but it should never be larger than the available memory pointed to by the rdBuf or wrBuf pointers.

Figure 1. Slave Buffer Structure

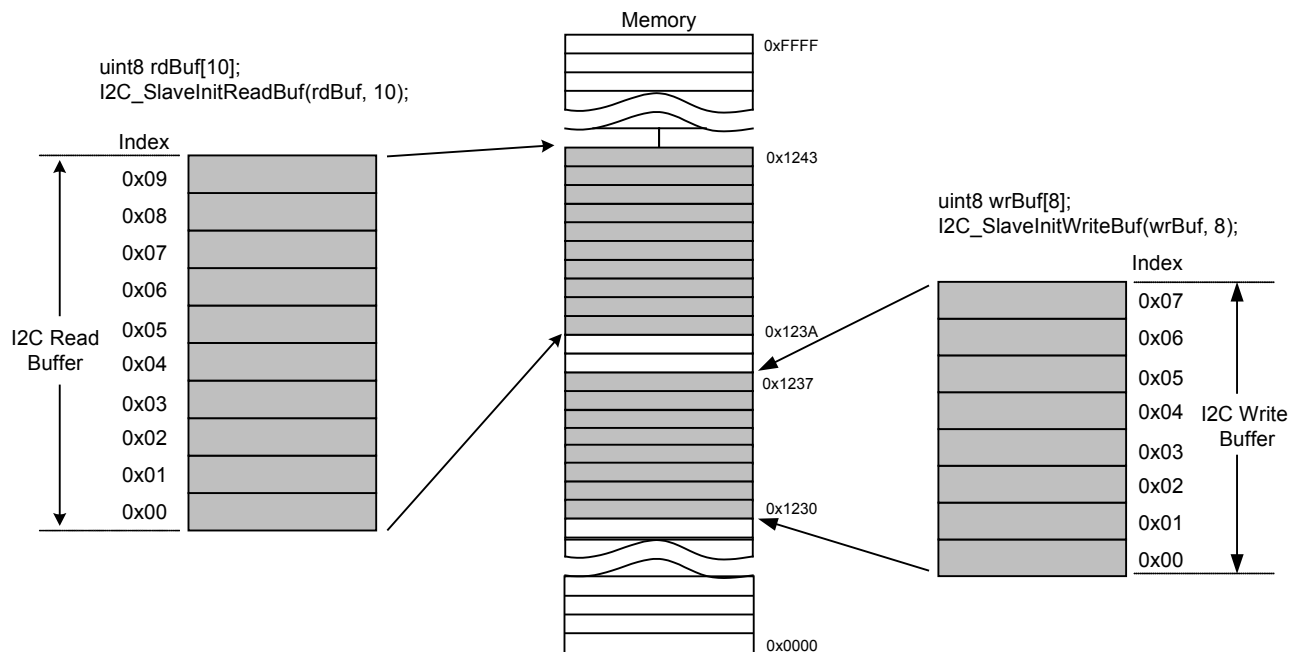

When the `I2C_SlaveInitReadBuf()` or `I2C_SlaveInitWriteBuf()` functions are called, the internal index is set to the first value in the array pointed to by `rdBuf` and `wrBuf`, respectively. As the I²C master reads or writes the bytes, the index is incremented until the offset is one less than the `byteCount`. At any time, the number of bytes transferred can be queried by calling either `I2C_SlaveGetReadBufSize()` or `I2C_SlaveGetWriteBufSize()` for the read and write buffers,

respectively. Reading or writing more bytes than are in the buffers causes an overflow error. The error is set in the slave status byte and can be read with the I2C_SlaveStatus() API.

To reset the index back to the beginning of the array, use the following commands.

```
void I2C_SlaveClearReadBuf(void)
void I2C_SlaveClearWriteBuf(void)
```

This resets the index back to zero. The next byte the I²C master reads or writes to is the first byte in the array. Before using these clear buffer commands, the data in the arrays should be read or updated.

Multiple reads or writes by the I²C master continue to increment the array index until the clear buffer commands are used or the array index tries to grow beyond the array size. Figure 2 shows an example where an I²C master has executed two write transactions. The first write was four bytes and the second write was six bytes. The sixth byte in the second transaction was ACKed by the slave because buffer has a room to store byte. If the master tried to write a seventh byte for the second transaction or started to write more bytes with a third transaction, each byte would be NAKed and discarded until the buffer is reset.

Using the I2C_SlaveClearWriteBuf() function after the first transaction resets the index back to zero and causes the second transaction to overwrite the data from the first transaction. Make sure data is not lost by overflowing the buffer. The data in the buffer should be processed by the slave before resetting the buffer index.

Figure 2. System Memory

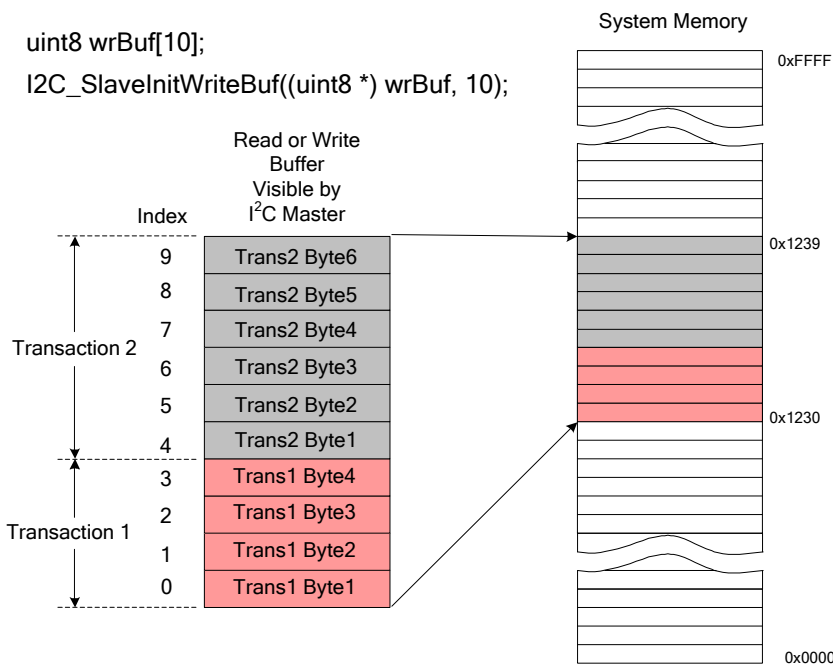

Both the read and write buffers have four status bits to signal transfer complete, transfer in progress, and buffer overflow. Starting a transfer sets the busy flag. When the transfer is



complete, the transfer complete flag is set and the busy flag is cleared. If a second transfer is started, both the busy and transfer complete flags can be set at the same time. The following table shows read and write status flags.

Slave Status Constants	Value	Description
I2C_SSTAT_RD_CMPLT	0x01	Slave read transfer complete
I2C_SSTAT_RD_BUSY	0x02	Slave read transfer in progress (busy)
I2C_SSTAT_RD_OVFL	0x04	Master attempted to read more bytes than are in the buffer
I2C_SSTAT_WR_CMPLT	0x10	Slave write transfer complete
I2C_SSTAT_WR_BUSY	0x20	Slave write transfer in progress (busy)
I2C_SSTAT_WR_OVFL	0x40	Master attempted to write past the end of the buffer

The following code example initializes the write buffer then waits for a transfer to complete. After the transfer is complete, the data is copied into a working array. In many applications, the data does not have to be copied to a second location, but instead can be processed in the original buffer. You could create an almost identical read buffer example by replacing the write functions and constants with read functions and constants. Processing the data may mean new data is transferred into the slave buffer instead of out.

```
uint8 wrBuf[10];
uint8 userArray[10];
uint8 byteCnt;

/* Initialize write buffer before call I2C_Start */
I2C_SlaveInitWriteBuf((uint8 *) wrBuf, 10);

/* Start I2C Slave operation */
I2C_Start();

/* Wait for I2C master to complete a write */

for(;;) /* loop forever */
{
    /* Wait for I2C master to complete a write */
    if(0u != (I2C_SlaveStatus() & I2C_SSTAT_WR_CMPLT))
    {
        byteCnt = I2C_SlaveGetWriteBufSize();
        I2C_SlaveClearWriteStatus();
        for(i=0; i < byteCnt; i++)
        {
            userArray[i] = wrBuf[i]; /* Transfer data */
        }
        I2C_SlaveClearWriteBuf();
    }
}
```

Master/Multi-Master Operation

Master and multi-master^{7,8} operation are basically the same, with two exceptions. When operating in multi-master mode, the program should always check the return status for a Start transaction. Another multi-master may already be communicating with another slave. In this case, the program must wait until that communication is completed and the bus becomes free. The program can wait in two ways: generate a Start transaction until the return status indicates success, or check the bus state until the bus becomes free and then generate a Start transaction. The multi-master transaction can be queued if another multi-master generates the Start faster. In this case, the error condition is not returned and a multi-master transaction is generated. This transaction is issued as soon as the bus becomes free.

The second difference is that, in multi-master mode, two masters can start at the same time. If this happens, one of the two masters loses arbitration.

- Automatic multi-master transaction: The component automatically checks for this condition and responds with an error if arbitration was lost. The multi-master transaction is considered complete (appropriate completion status flags are set) when arbitration is lost.
- Manual multi-master transaction: You must check for the return condition after each byte is transferred.

There are two options when operating the I²C master: manual and automatic. In the automatic mode, a buffer is created to hold the entire transfer. In the case of a write operation, the buffer is prefilled with the data to be sent. If data is to be read from the slave, you need to allocate a buffer at least the size of the packet. To write an array of bytes to a slave in automatic mode, use the following function.

```
uint8 I2C_MasterWriteBuf(uint8 slaveAddress, uint8 * wrData, uint8 cnt, uint8 mode)
```

The `slaveAddress` variable is a right-justified 7-bit slave address of 0 to 127. The component API automatically appends the write flag to the LSB of the address byte. The second parameter, `xferData`, points to the array of data to transfer. The `cnt` parameter is the number of bytes to transfer. The last parameter, `mode`, determines how the transfer starts and stops. A transaction can begin with a Restart instead of a Start, or halt before the Stop sequence. These options allow back-to-back transfers where the last transfer does not send a Stop and the next transfer issues a Restart instead of a Start.

⁷ In fixed-function implementation for PSoC 5 in master or multi-master mode, if the software sets the Stop condition immediately after the Start condition, the module generates the Stop condition. This happens after the address field (sends 0xFF if data write), and the clock line remains low. To avoid this condition, do not set the Stop condition immediately after Start; transfer at least a byte and set the Stop condition after NAK or ACK.

⁸ Fixed-function implementation does not support undefined bus conditions. Avoid these conditions, or use the UDB-based implementation instead.

A read operation is almost identical to the write operation. It uses the same parameters with the same constants.

```
uint8 I2C_MasterReadBuf(uint8 slaveAddress, uint8 * rdData, uint8 cnt, uint8
mode);
```

Both of these functions return status. See the status table for the I2C_MasterStatus() function return value. Because the read and write transfers complete in the background during the I²C interrupt code, you can use the I2C_MasterStatus() function to determine when the transfer is complete. A code snippet that shows a typical write to a slave follows.

```
I2C_MasterClearStatus(); /* Clear any previous status */
I2C_MasterWriteBuf(0x08, (uint8 *) wrData, 10, I2C_MODE_COMPLETE_XFER);
for(;;)
{
    if(0u != (I2C_MasterStatus() & I2C_MSTAT_WR_CMPLT))
    {
        /* Transfer complete. Check Master status to make sure that transfer
        completed without errors. */

        break;
    }
}
```

The I²C master can also be operated manually. In this mode, each part of the write transaction is performed with individual commands.

```
status = I2C_MasterSendStart(0x08, I2C_WRITE_XFER_MODE);
if(I2C_MSTR_NO_ERROR == status) /* Check if transfer completed without errors */
{
    /* Send array of 5 bytes */
    for(i=0; i<5; i++)
    {
        status = I2C_MasterWriteByte(userArray[i]);
        if(status != I2C_MSTR_NO_ERROR)
        {
            break;
        }
    }
}
I2C_MasterSendStop(); /* Send Stop */
```

A manual read transaction is similar to the write transaction except the last byte should be NAKed. The following example shows a typical manual read transaction.

```
status = I2C_MasterSendStart(0x08, I2C_READ_XFER_MODE);
if(I2C_MSTR_NO_ERROR == status) /* Check if transfer completed without errors */
{
    /* Read array of 5 bytes */
    for(i=0; i<5; i++)
    {
        if(i < 4)
        {
```



```

        userArray[i] = I2C_MasterReadByte(I2C_ACK_DATA);
    }
    else
    {
        userArray[i] = I2C_MasterReadByte(I2C_NAK_DATA);
    }
}
I2C_MasterSendStop();    /* Send Stop */

```

Multi-Master-Slave Mode Operation

Both multi-master and slave work in this mode. The component can be addressed as a slave, but firmware can also initiate master mode transfers. In this mode, when a master loses arbitration during an address byte, the hardware reverts to slave mode and the received byte generates a slave address interrupt.

For master and slave operation examples, see the [Slave Operation](#) and [Master/Multi-Master Operation](#) sections.

Arbitrage on address byte limitations with hardware address match enabled: When a master loses arbitration during an address byte, the slave address interrupt is generated only if the slave is addressed. In other cases, the lost arbitrage status is lost by interrupt-based functions. The software address detect eliminates this possibility, but excludes the Wakeup on Hardware Address Match feature.

The manual function `I2C_MasterSendStart()` provides correct status information in the case just described.

Start of Multi-Master-Slave Transfer

When using multi-master-slave, the slave can be addressed at any time. The multi-master must take time to prepare to generate a Start condition when the bus is free. During this time, the slave could be addressed and, if so, the multi-master transaction is lost and the slave operation proceeds. Be careful not to break the slave operation; the I²C interrupt must be disabled before generating a Start condition to prevent the transaction from passing the address stage. This action allows you to abort a multi-master transaction and start a slave operation correctly. The following cases are possible when disabling the I²C interrupt:

- The bus is busy (slave operation is in progress or other traffic is on the bus) before Start generation. The multi-master does not try to generate a Start condition. Slave operation proceeds when the I²C interrupt is enabled. The `I2C_MasterWriteBuf()`, `I2C_MasterReadBuf()`, or `I2C_MasterSendStart()` call returns the status **I2C_MSTR_BUS_BUSY**.
- The bus is free before Start generation. The multi-master generates a Start condition on the bus and proceeds with operation when the I²C interrupt is enabled. The



I2C_MasterWriteBuf(), I2C_MasterReadBuf(), or I2C_MasterSendStart() call returns the status **I2C_MSTR_NO_ERROR**.

- The bus is free before Start generation. The multi-master tries to generate a Start but another multi-master addresses the slave before this and the bus becomes busy. The Start condition generation is queued. The slave operation stops at the address stage because of a disabled I²C interrupt. When the I²C interrupt is enabled, the multi-master transaction is aborted from the queue and the slave operation proceeds. The I2C_MasterWriteBuf() or I2C_MasterReadBuf() call does not notice this and returns **I2C_MSTR_NO_ERROR**. The I2C_MasterStatus() returns **I2C_MSTAT_WR_CMPLT** or **I2C_MSTAT_RD_CMPLT** with **I2C_MSTAT_ERR_XFER** (all other error condition bits are cleared) after the multi-master transaction is aborted. The I2C_MasterSendStart() call returns the error status **I2C_MSTR_ERR_ABORT_START_GEN**.

Interrupt Function Operation

```

I2C_MasterWriteBuf();
I2C_MasterReadBuf();
I2C_MasterClearStatus();      /* Clear any previous status */
I2C_DisableInt();             /* Disable interrupt */

status = I2C_MasterWriteBuf(0x08, (uint8 *) wrData, 10, I2C_MODE_COMPLETE_XFER);
/* Try to generate, start. The disabled I2C interrupt halt the transaction on
address stage in case of Slave addressed or Master generates start condition */
I2C_EnableInt();             /* Enable interrupt and proceed Master or Slave transaction */

for(;;)
{
    if(0u != (I2C_MasterStatus() & I2C_MSTAT_WR_CMPLT))
    {
        /* Transfer complete. Check Master status to make sure that transfer
        completed without errors. */
        break;
    }
}

if (0u != (I2C_MasterStatus() & I2C_MSTAT_ERR_XFER))
{
    /* Error occurred while transfer, clean up Master status and
    retry the transfer */
}

```

Manual Function Operation

Manual multi-master operation assumes that the I²C interrupt is disabled, but it is best to take the following precaution:

```

I2C_DisableInt();             /* Disable interrupt */
/* Try to generate start condition */
status = I2C_MasterSendStart(0x08, I2C_WRITE_XFER_MODE);
/* Check if start generation completed without errors */

```



```

if (I2C_MSTR_NO_ERROR ==status)
{
    /* Proceed the write operation */
    /* Send array of 5 bytes */
    for (i=0; i<5; i++)
    {
        status = I2C_MasterWriteByte(userArray[i]);
        if (status != I2C_MSTR_NO_ERROR)
        {
            break;
        }
    }
    I2C_MasterSendStop(); /* Send Stop */
}
I2C_EnableInt(); /* Enable interrupt, if it was enabled before */

```

Wakeup on Hardware Address Match

The wakeup from sleep on I²C address match event is possible if the following conditions are met:

- The I²C slave is enabled. Slave or multi-master-slave mode is selected.
- I²C Hardware address detection is selected.
- The SIO pair is connected to SCL and SDA and the proper pair is selected in the customizer: I2C0 – SCL P12[4], SDA P12[5] and I2C1 – SCL P12[0], SDA P12[1].

The I²C component customizer controls these conditions, **except correct pin assignments**.

How it Works

The I²C block responds to transactions on the I²C bus during sleep mode. The I²C wakes the system if the incoming address matches with the slave address. Once the address matches, a wakeup interrupt is asserted to wake up the system and SCL is pulled low. The ACK is sent out after the system wakes up and the CPU determines the next action in the transaction.

Wakeup and Clock Stretching

The I²C slave stretches the clock while exiting sleep mode. All clocks in the system must be restored before continuing the I²C transaction after wakeup. The I²C interrupt remains enabled but interrupt handler is changed before going to sleep. Wakeup on address match triggers I²C interrupt and I²C wakeup flag is set to notify that. Call I2C_Wakeup() function changes interrupt handler to regular I²C and generates interrupt based on I²C wakeup flag to process in-coming transaction. The SCL line remains low after wakeup until I2C_Wake() is called.

Sample code:

```

I2C_Sleep(); /* Prepare I2C to be able wake up from Sleep mode*/
CyPmSaveClocks(); /* Save clocks settings */

```



```

CyPmSleep(PM_SLEEP_TIME_NONE, PM_SLEEP_SRC_I2C);

CyPmRestoreClocks(); /* Restore clocks */
I2C_Wakeup(); /* Returns I2C for operation in Active mode */
...
    
```

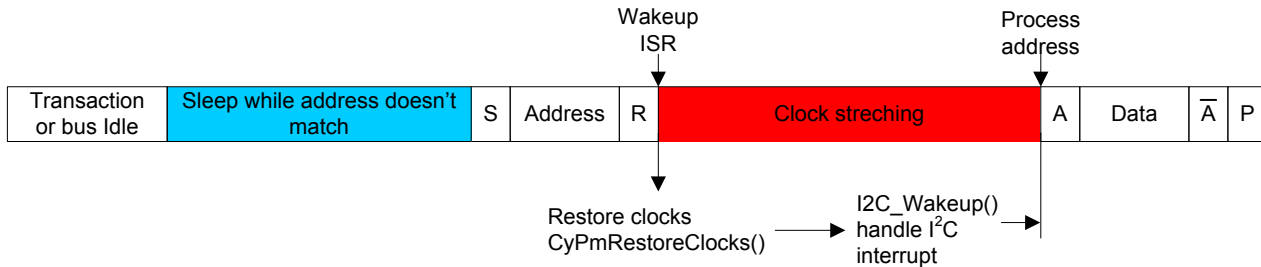

Bootloader Protocol Interaction with I²C Communication Component

The bootloader protocol is implemented as command (write transaction) and response (read transaction).

The time between the host issuing the command and the bootloader sending back the response is the command execution time. The I²C communication component for the bootloader is designed in this way: when the host asks for a response, and the bootloader still executes a command, 0xFF is returned.

Startup: The I²C bootloader communication component expects to receive the command and does not yet have a valid response. All read transactions from the host return 0xFF. All write transactions are treated as commands.

Bootloader process: The host is issued the command with a single write transaction and starts polling for a response. The I²C communication component answers with 0xFF until a valid response is passed by the bootloader. After receiving 0x01, the host must perform another read to get the remaining N – 1 bytes of the response. After both reads are complete, the results are combined to form the full response packet.

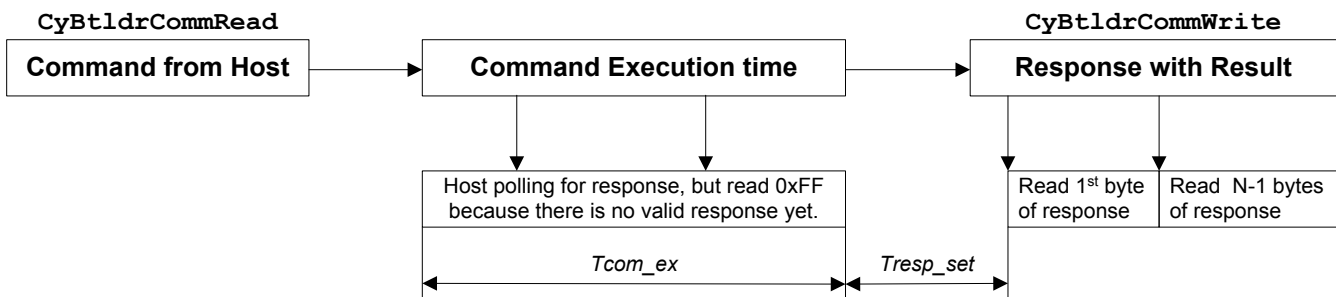

The host must execute polling by reading one byte; reading more bytes could corrupt the response. For example, in the case of 0xFF 0x01 0x03 (two bytes of response were read,



instead of one), the next read of the full response returns two invalid bytes, because these bytes were already read (0x01 and 0x03).

How to avoid polling: You should measure the command execution time (Tcom_ex) plus the response setup time (Tresp_set) according to the system settings (CPU speed, compiler, compiler optimization level). The host must ask for the response after this time. The command execution time changes across the commands, so you should choose the greater time.

Clock stretching while polling: The I²C communication component requires that interrupts be enabled while in operation. The Command Program Row (0x39), which writes one row of flash data to the device, requires interrupts to be disabled. Clock stretching occurs if the address is accepted by the I²C communication component while interrupts are disabled.

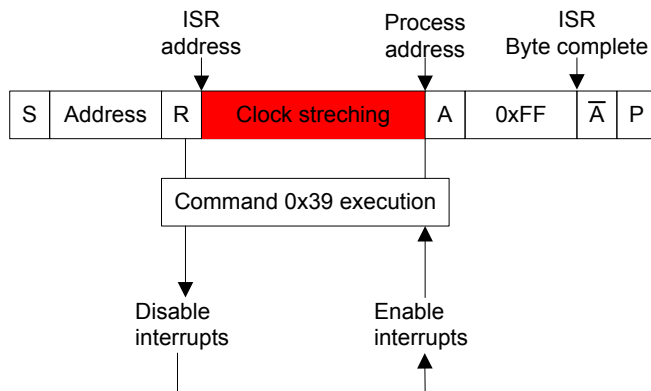

How to avoid clock stretching: To avoid clock stretching, measure the Command Program Row (0x39) execution time (Tcom_ex) according to the system settings (CPU speed, compiler, and compiler optimization level). The host must ask for a response after this time.

Internal I²C Bus Multiplexing

Selecting the **External OE buffer** option allows internal I²C bus multiplexing. The internal OE buffers are removed and bidirectional scl and sda terminals are replaced with separate inputs sda_i and scl_i and outputs sda_o and scl_o. The following figure shows an example of a 2:1 I²C slave mux implemented using a schematic. It can easily be extended to support an N:1 mux. The same idea can be used to connect an I²C master to multiple external downstream I²C buses.

The digital multiplexers are used for selection of sda_o and scl_o from different I²C buses. The and gates are used to join sda_i and scl_i signals. The tri-state buffers are used to make possible control of bidirectional nature of the I²C interface.

To select between I²C buses, the control register (I2C_Bus_Select) must be set accordingly.

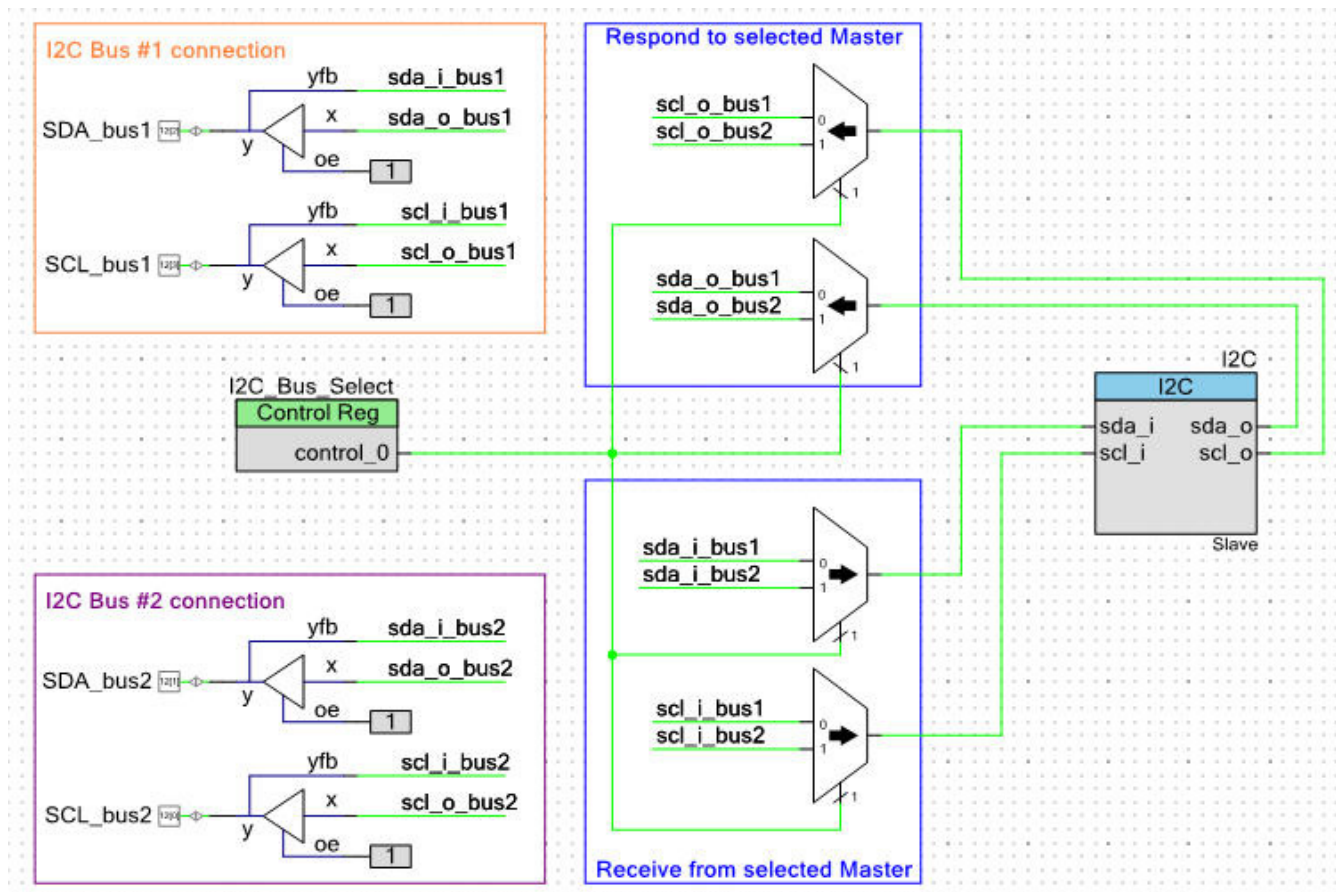

Figure 3. Internal I²C Bus Multiplexing

External Electrical Connections

As Figure 4 shows, the I²C bus requires external pull-up resistors. The pull-up resistors (R_P) are determined by the supply voltage, clock speed, and bus capacitance. Make the minimum sink current for any device (master or slave) no less than 3 mA at $V_{OLmax} = 0.4$ V for the output stage. This limits the minimum pull-up resistor value for a 5-V system to about 1.5 k Ω . The maximum value for R_P depends upon the bus capacitance and clock speed. For a 5-V system with a bus capacitance of 150 pF, the pull-up resistors are no larger than 6 k Ω . For more information about sizing pull-up resistors and other physical bus specifications, see *The I²C-Bus Specification* on the NXP web site at www.nxp.com.

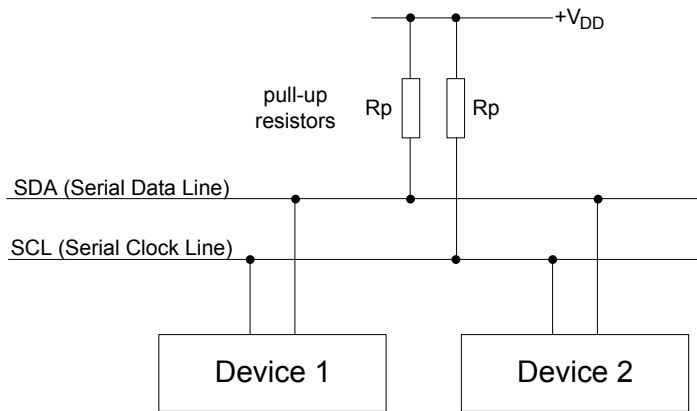
Figure 4. Connection of Devices to the I²C Bus

Note Purchase of I²C components from Cypress or one of its sublicensed Associated Companies, conveys a license under the Philips I²C Patent Rights to use these components in an I²C system, provided that the system conforms to the I²C Standard Specification as defined by Philips. As of October 1, 2006, Philips Semiconductors has a new trade name - NXP Semiconductors.

Interrupt Service Routine

The interrupt service routine is used by the component code. Do not change it.

The following user sections are provided for slave operations:

- Custom includes and definitions
- Additional address compare
- Prepare read buffer

There are no user sections provided for master operations.

The I²C component uses interrupts for most operations; the status of a transaction is updated there. Status read and clear functions are not protected from interruption. These functions are listed below:

Master or multi-master:

- I2C_MasterStatus()
- I2C_MasterClearStatus()
- I2C_MasterGetReadBufSize()
- I2C_MasterGetWriteBufSize()
- I2C_MasterClearReadBuf()



- I2C_MasterClearWriteBuf()

Slave:

- I2C_SlaveStatus()
- I2C_SlaveClearReadStatus()
- I2C_SlaveClearWriteStatus()
- I2C_SlaveInitReadBuf()
- I2C_SlaveInitWriteBuf()
- I2C_SlaveGetReadBufSize()
- I2C_SlaveGetWriteBufSize()
- I2C_SlaveClearReadBuf()
- I2C_SlaveClearWriteBuf()

Registers

The functions provided support the common run-time functions required for most applications. The following register references provide brief descriptions for the advanced user. The I2C_Data register may be used to write data directly to the bus without using the API. This can be useful for either CPU or DMA use.

The registers available to each of the configurations of the I²C component are grouped according to the implementation as fixed function or UDB.

Fixed-Function Master/Slave Registers

See the chip Technical Reference Manual (TRM) for more information about these registers. All bits that are added in the PSoC 3 and PSoC 5LP devices are indicated with an asterisk (*) in the definitions listed below.

I2C_XCFG

The extended configuration register is available in the fixed-function hardware block to configure the hardware address mode and clock source.

Bits	7	6	5	4	3	2	1	0
Value	csr_clk_en	i2c_on*	ready_to_sleep*	force_nak*	RSVD			hw_addr_en

- csr_clk_en: Used to enable gating for the fixed-function block core logic.



- `i2c_on*`: Used to select the I²C block as the wakeup source.
- `ready_to_sleep*`: Used to notify that the block is ready to sleep.
- `force_nak*`: Used to force NAK the transaction.
- `hw_addr_en`: Used to enable hardware address comparison mode.

I2C_ADDR

The slave address register is available in the fixed-function hardware block to configure the slave device address for hardware comparison mode, if enabled in the XCFG register.

Bits	7	6	5	4	3	2	1	0
Value	RSVD	slave_address						

- `slave_address`: Used to define the 7-bit slave address for hardware address comparison mode.

I2C_CFG

The configuration register is available in the fixed-function hardware block to configure the basic functionality.

Bits	7	6	5	4	3	2	1	0
Value	sio_select	pselect	bus_error_ie	stop_ie	clock_rate[1:0]		en_mstr	en_slave

- `sio_select`: Used to select between SIO1 and SIO2 lines for SCL and SDA; `pselect` must be set for this bit to have an effect.
- `pselect`: Used to select between SIO direct connections or DSI routed GPIO/SIO pins for the SCL and SDA lines.
- `bus_error_ie`: Used to enable interrupt generation for `bus_error`.
- `stop_ie`: Used to enable interrupt generation on stop bit detection.
- `clock_rate`: Used to select between 16-bit or 32-bit oversample. PSoC 3 and PSoC 5LP uses only bit2.
- `en_mstr`: Used to enable master mode.
- `en_slave`: Used to enable slave mode.



I2C_CSR

The control and status register is available in the fixed-function hardware block for run-time control and status feedback.

Bits	7	6	5	4	3	2	1	0
Value	bus_error	lost_arb*	stop_status	ack	address	transmit	lrb	byte_complete

- bus_error: Bus error detection status bit. This must be cleared by writing a '0' to this bit position.
- lost_arb*: Lost arbitration detection status bit.
- stop_status: Stop detection status bit. This must be cleared by writing a '0' to this position.
- ack: Acknowledge control bit. This bit must be set to 1 to ACK the last byte received or 0 to NAK the last byte received.
- address: Set if the byte just received was an address byte.
- transmit: Used by firmware to define the direction of a byte transfer.
- lrb: Last Received Bit status. This bit indicates the state of the ninth bit (ACK/NAK) response from the receiver for the last byte transmitted.
- byte_complete: Transmit or receive status since the last read of this register. In transmit mode, this bit indicates that eight bits of data plus ACK/NAK have been transmitted since the last read. In receive mode, this bit indicates that eight bits of data have been received since the last read of this register.

I2C_DATA

The data register is available in the fixed-function hardware block for run-time transmission and receipt of data.

Bits	7	6	5	4	3	2	1	0
Value	data							

- data: In Transmit mode this register is written with the data to transmit. In receive mode this register is read upon status receipt of byte_complete.

I2C_MCSR

The master control and status register is available in the fixed-function hardware block for run-time control and status feedback of master mode operations.

Bits	7	6	5	4	3	2	1	0
Value	RSVD			stop_gen*	bus_busy	master_mode	restart_gen	start_gen

- stop_gen*: If set, a Stop is generated in master transmitter mode at the end of a byte transfer
- bus_busy: Indicates bus status. 0 means a Stop condition was detected, 1 indicates a Start condition was detected.
- master_mode: Indicates that a valid Start condition was generated and a hardware device is operating as bus master.
- restart_gen: Control registers to create a Restart condition on the bus. This bit is cleared by hardware after the Restart has been implemented (may be read as status after setting to poll for completion of the condition).
- start_gen: Control registers to create a Start condition on the bus. This bit is cleared by hardware after the Start has been implemented (may be read as status after setting to poll for completion of the condition).

UDB Master

The UDB register definitions are derived from the Verilog implementation of I²C. See the specific mode implementation Verilog for more information about these registers' definitions.

I2C_CFG

The control register is available in the UDB implementation for run-time control of the hardware

Bits	7	6	5	4	3	2	1	0
Value	start_gen	stop_gen	restart_gen	ack	RSVD	transmit	en_master	RSVD

- start_gen: Set to 1 to generate a Start condition on the bus. This bit must be cleared by firmware before initiating the next transaction.
- stop_gen: Set to 1 to generate a Stop condition on the bus. This bit must be cleared by firmware before initiating the next transaction.
- restart_gen: Set to 1 to generate a Restart condition on the bus. This bit must be cleared by firmware after a Restart condition is generated.



- **ack**: Set to 1 to NAK the next read byte. Clear to ACK next read byte. This bit must be cleared by firmware between bytes.
- **transmit**: Set to 1 to set the current mode to transmit or clear to 0 to receive a byte of data. This bit must be cleared by firmware before starting the next transmit or receive transaction.
- **en_master**: Set to 1 to enable the master functionality.

I2C_CSR

The status register is available in the UDB implementation for run-time status feedback from the hardware. The status data is registered at the input clock edge of the counter for all bits configured with mode = 1. These bits are sticky and are cleared on a read of the status register. All other bits are configured as mode = 0 read directly from the inputs to the status register. They are not sticky and therefore not cleared on read. All bits configured as mode = 1 are indicated with an asterisk (*) in the following definitions.

Bits	7	6	5	4	3	2	1	0
Value	RSVD	lost_arb*	stop_status*	bus_busy	address	master_mode	lrb	byte_complete

- **lost_arb***: If set, indicates arbitration was lost (multi-master and multi-master-slave modes).
- **stop_status***: If set, indicates a Stop condition was detected on the bus.
- **bus_busy**: If set, indicates the bus is busy. Data is currently being transmitted or received.
- **address**: Address detection. If set, indicates that an address byte was sent.
- **master_mode**: Indicates that a valid Start condition was generated and a hardware device is operating as bus master.
- **lrb**: Last Received Bit. Indicates the state of the last received bit, which is the ACK/NAK received for the last byte transmitted. Cleared = ACK and set = NAK.
- **byte_complete**: Transmit or receive status since the last read of this register. In Transmit mode this bit indicates that eight bits of data plus ACK/NAK have been transmitted since the last read. In Receive mode this bit indicates that eight bits of data have been received since the last read of this register.

I2C_INT_MASK

The interrupt mask register is available in the UDB implementation to specify which status bits are enabled as interrupt sources. Any of the status register bits can be enabled as an interrupt source with a one-to-one bit correlation to the status register's bit-field definitions in I2C_CSR.



I2C_ADDRESS

The slave address register is available in the UDB implementation to configure the slave device address for hardware comparison mode.

Bits	7	6	5	4	3	2	1	0
Value	RSVD	slave_address						

- slave_address: Used to define the 7-bit slave address for hardware address comparison mode

I2C_DATA

The data register is available in the UDB implementation block for run-time transmission and receipt of data.

Bits	7	6	5	4	3	2	1	0
Value	data							

- data: In transmit mode this register is written with the data to transmit. In receive mode this register is read upon status receipt of byte_complete.

I2C_GO

The Go register forces the data in the data register to be transmitted when the master transmits. The Go register forces the data to be received in the data register when the master receives. Any write to this register forces this action, no matter which value is written.

UDB Slave

The UDB register definitions are derived from the Verilog implementation of I²C. See the specific mode implementation Verilog for more information about these registers' definitions.

I2C_CFG

The control register is available in the UDB implementation for run-time control of the hardware

Bits	7	6	5	4	3	2	1	0
Value	RSVD	RSVD	RSVD	nak	any_address	transmit	RSVD	en_slave

- nak: If set, used to NAK the last byte received. This bit must be cleared by firmware between bytes.
- any_address: If set, used to enable the device to respond any device addresses it receives rather than just the single address provided in I2C_ADDRESS.



- **transmit**: Used to set the mode to transmit or receive data. This bit must be cleared by firmware between bytes. Set = transmit and cleared = receive.
- **en_slave**: Set to 1 to enable the slave functionality.

I2C_CSR

The status register is available in the UDB implementation for run-time status feedback from the hardware. The status data is registered at the input clock edge of the counter for all bits configured with mode = 1. These bits are sticky and are cleared on a read of the status register. All other bits are configured as mode = 0 and read directly from the inputs to the status register. They are not sticky and therefore not cleared on read. All bits configured as mode = 1 are indicated with an asterisk (*) in the definitions listed below.

Bits	7	6	5	4	3	2	1	0
Value	RSVD	RSVD	stop*	RSVD	address	RSVD	lrb	byte_complete

- **stop***: If set, indicates a Stop condition was detected on the bus.
- **address**: Address detection. If set, indicates that an address byte was received.
- **lrb**: Last Received Bit. Indicates the state of the last received bit, which is the ACK/NAK received for the last byte transmitted. Cleared = ACK and set = NAK.
- **byte_complete**: Transmit or receive status since the last read of this register. In transmit mode this bit indicates that eight bits of data plus ACK/NAK have been transmitted since the last read. In Receive mode this bit indicates that eight bits of data have been received since the last read of this register.

I2C_INT_MASK

The interrupt mask register is available in the UDB implementation to specify which status bits are enabled as interrupt sources. Any of the status register bits can be enabled as an interrupt source with a one-to-one bit correlation to the status register bit-field definitions in the I2C_CSR register. Two interrupt sources are used during operation: **byte_complete** and **stop**.

I2C_ADDRESS

The slave address register is available in the UDB implementation to configure the slave device address for hardware comparison mode.

Bits	7	6	5	4	3	2	1	0
Value	RSVD	slave_address						

- **slave_address**: Used to define the 7-bit slave address for hardware address comparison mode



I2C_DATA

The data register is available in the UDB implementation block for run-time transmission and receipt of data.

Bits	7	6	5	4	3	2	1	0
Value	data							

- data: In transmit mode this register is written with the data to transmit. In receive mode this register is read upon status receipt of byte_complete.

I2C_GO

The Go register forces data in the data register to be transmitted when master transmits. The Go register forces the data register to receive data when the master receives. Any write to this register forces this action, no matter which value is written.

Resources

The fixed I²C block and one interrupt are used for fixed-function implementation.

The UDB version of component utilizes the following resources.

Configuration	Resource Type					
	Datapath Cells	Macrocells	Status Cells	Control Cells	DMA Channels	Interrupts
Slave	1	25	1	2	–	1
Master	2	33	1	1	–	1
Multi-Master	2	36	1	1	–	1
Multi-Master-Slave	2	65	1	2	–	1

API Memory Usage

The component memory usage varies significantly, depending on the compiler, device, number of APIs used and component configuration. The following table provides the memory usage for all APIs available in the given component configuration.

The measurements have been done with associated compiler configured in Release mode with optimization set for Size. For a specific design the map file generated by the compiler can be analyzed to determine the memory usage.

API Memory Usage (FF Implementation)

Configuration	PSoC 3 (Keil_PK51)		PSoC 5 (GCC)		PSoC 5LP (GCC)	
	Flash Bytes	SRAM Bytes	Flash Bytes	SRAM Bytes	Flash Bytes	SRAM Bytes
Slave	1155	20	1155	20	1368	27
Master	1754	19	1902	22	2018	26
Multi-Master	1866	19	2026	22	2138	26
Multi-Master-Slave	2707	32	2719	32	3054	27

API Memory Usage (UDB Implementation)

Configuration	PSoC 3 (Keil_PK51)		PSoC 5 (GCC)		PSoC 5LP (GCC)	
	Flash Bytes	SRAM Bytes	Flash Bytes	SRAM Bytes	Flash Bytes	SRAM Bytes
Slave	927	16	1176	23	1104	23
Master	1703	16	2034	22	1962	22
Multi-Master	1857	16	2190	22	2114	22
Multi-Master-Slave	2640	28	3098	23	2974	23

DC and AC Electrical Characteristics

Specifications are valid for $-40\text{ °C} \leq T_A \leq 85\text{ °C}$ and $T_J \leq 100\text{ °C}$, except where noted.
Specifications are valid for 1.71 V to 5.5 V, except where noted.

DC Characteristics (FF Implementation)

Parameter	Description	Conditions	Min	Typ	Max	Units
	Block current consumption	Enabled, configured for 100 kbps	–	–	250	μA
		Enabled, configured for 400 kbps	–	–	260	μA
		Wake from sleep mode	–	–	30	μA

DC Characteristics (UDB Implementation)

Parameter	Description		Min	Typ ^[9]	Max	Unit ^[10]	
I _{DD(Slave)}	Component current consumption (Slave)	Standard mode	–	200	–	μA	
		Fast mode	–	290	–	μA	
		Fast mode plus	–	335	–	μA	
I _{DD(Master)}	Component current consumption (Master)	Standard mode	–	210	–	μA	
		Fast mode	–	305	–	μA	
		Fast mode plus	–	465	–	μA	
I _{DD(Multi-Master)}	Component current consumption (Multi-Master)	Standard mode	–	215	–	μA	
		Fast mode	–	320	–	μA	
		Fast mode plus	–	515	–	μA	
I _{DD(Multi-Master-Slave)}	Component current consumption (Multi-Master-Slave)	Slave operation	Standard mode	–	200	–	μA
			Fast mode	–	290	–	μA
			Fast mode plus	–	335	–	μA
		Multi-Master operation	Standard mode	–	215	–	μA
			Fast mode	–	320	–	μA
			Fast mode plus	–	515	–	μA

⁹ Device IO and clock distribution current not included. The values are at 25 °C.

¹⁰ Current consumption is specified with respect to the incoming component clock.

AC Characteristics (FF Implementation)

Parameter	Description	Conditions	Min	Typ	Max	Unit
	Bit rate		--	--	1	Mbps

AC Characteristics (UDB Implementation)

Parameter	Description	Min	Typ	Max	Unit
f _{SCL}	SCL clock frequency	– – –	– – –	100 400 1000	kHz
f _{CLOCK}	Component input clock frequency	–	16 × f _{SCL}	–	kHz
t _{RESET}	Reset pulse width	–	2	–	t _{CY_clock} ¹¹
t _{LOW}	Low period of the SCL clock	4.7 1.3 0.5	– – –	– – –	μs
t _{HIGH}	High period of the SCL clock	4.0 0.6 0.26	– – –	– – –	μs
t _{HD_STA}	Hold time (repeated) start condition	4.0 0.6 0.26	– – –	– – –	μs
t _{SU_STA}	Setup time for a repeated start condition	4.7 0.6 0.26	– – –	– – –	μs
t _{HD_DAT}	Data hold time	5.0 – –	– – –	– – –	μs
t _{SU_DAT}	Data setup time	250 100 50	– – –	– – –	ns
t _{SU_STO}	Setup time for stop condition	4.0 0.6 0.26	– – –	– – –	μs

¹¹ t_{CY_clock} = 1/f_{CLOCK}. This is the cycle time of one clock period.

Parameter	Description	Min	Typ	Max	Unit
t _{BUF}	Bus free time between a stop and start condition	4.7	–	–	μs
		1.3	–	–	
		0.5	–	–	

Figure 5. Data Transition Timing Diagram

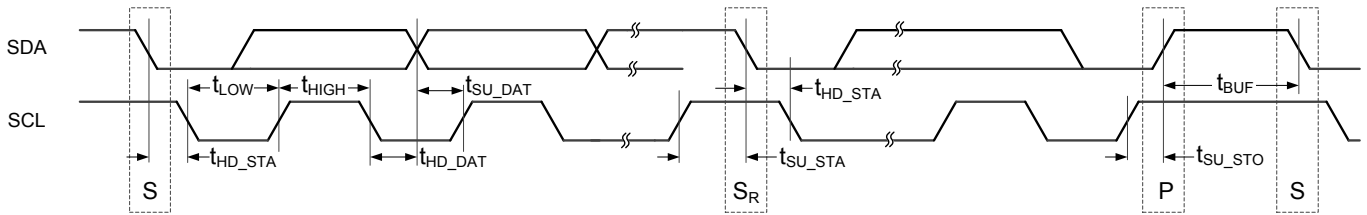

Component Errata

This section lists known problems with the component.

Cypress ID	Component Version	Problem	Workaround
191257	v3.30	This component was modified without a version number change in PSoC Creator 3.0 SP1. For further information, see Knowledge Base Article KBA94159 (www.cypress.com/go/kba94159).	No workaround is necessary. There is no impact to designs.

Component Changes

This section lists the major changes in the component from the previous version.

Version	Description of Changes	Reason for Changes / Impact
3.30.b	Edited datasheet to add Component Errata section.	Document that the component was changed, but there is no impact to designs.
3.30.a	Edited the datasheet.	Updated the diagram in When to Use an I ² C Component section. Clarified that the fixed-function implementation uses one interrupt.
3.30	Added MISRA Compliance section.	The component has specific deviations described.
	Fixed incorrect behavior of the master manual APIs when lost arbitration occurs.	On a lost arbitration event, the master manual APIs returned the proper status but did not release the I ² C bus. Code was added to release the bus when the lost arbitration event takes place.
	Added footnote about non-compliant with the NXP I ² C specification in some areas.	Documentation enhancement.
	Minor datasheet edits and updates.	
3.20	New feature was added. Removed the internal OE buffer and exposed the input and output terminals.	This feature allows I ² C buses multiplexing inside PSoC.
	Changed the control flow of the wake up sequence to avoid disabling the I ² C interrupt.	PSoC 5LP requires an I ² C interrupt to be enabled in order to wake up the device at the event of an address match.
	Moved the Stop interrupt to be handled at the start of a new transaction.	The Stop interrupt was occurring while the next transaction was beginning. This caused the interrupt code to get into an improper state and it did not catch the Stop interrupt. This issue applied to only the slave devices.
3.10	Added support PSoC 5LP.	
	Fixed wrong SDA behavior (the line drives low) after address byte was received.	When master generates transaction with slave address expected to be NAKed, the wrong Stop detection is possible. The issue only appears in Slave mode with Software Address Decode and UDB-based implementation.
3.1.a	Documentation change describing how the effective data rate will vary.	For data rates above 400 kbps, the effective clock rate can vary.
	Documentation change describing the difference between master and multi-master modes.	When operating in multi-master mode there are special considerations to take into account to handle correct interaction with other masters.

Version	Description of Changes	Reason for Changes / Impact
3.1	Changed the definition from I2C_SSTAT_RD_CMPT to I2C_SSTAT_RD_CMPLT Changed the definition from I2C_SSTAT_WR_CMPT to I2C_SSTAT_WR_CMPLT	To comply with the master definition of read and write complete flags. The component supports both definitions, but the I2C_SSTAT_RD_CMPT and I2C_SSTAT_WR_CMPT will become obsolete.
	Added the CYREENTRANT keyword to all APIs when they are included in the .cyre file.	Not all APIs are truly reentrant. Comments in the component API source files indicate which functions are not candidates. This change is required to eliminate compiler warnings for functions that are not reentrant used in a safe way: protected from concurrent calls by flags or Critical Sections.
3.0.a	Minor datasheet edits and updates	
3.0	Changed customizer appearance	More intuitive and easy to use.
	Added the UDB clock tolerance setting.	Avoids the appearance of clock warning for many configurations.
	The component in FF implantation with Enable from Sleep option restores configuration correctly after exit hibernate.	Fix component behavior in hibernate mode.
	The I ² C interrupt is enabled after I2C_Start() is called.	No errors appear when the user forgets to enable interrupt after I2C_Start() in slave mode.
	Added support of internal clock for UDB implementation.	Functionality enhancement.
	Removed functions I2C_SlaveGetWriteByte() and I2C_SlavePutReadByte()	These functions are not usable.
2.20	Added bootloader communication support to UDB-based implementation of component.	Allows more than one I ² C component that supports bootloading in the design. This can be used with the custom bootloader feature included with cy_boot v2.21.
	Fixed misplaced start condition detection during transaction due zero data hold time.	The slave operates correctly with zero data hold time from the master.
2.10	Added multi-master-slave mode	The support of multi-master-slave functionality is added to component.
	Customizer labels and description edits	Improve feel and content of component customizer.
	Changed I ² C bootloader communication component behavior to suppress clock stretching on read.	I ² C bootloader communication component holds SCL low forever if a read command is issued before the start boot process.
	Added characterization data to datasheet.	



Version	Description of Changes	Reason for Changes / Impact
	Minor datasheet edits and updates	
2.0.a	Moved the component into subfolders of the component catalog	
	Minor datasheet edits and updates	
2.0	Added Sleep/Wakeup and Init/Enable APIs.	To support low-power modes, as well as to provide common interfaces to separate control of initialization and enabling of most components.
	Updated the component to support Production PSoC 3 and above. Updated the Configure dialog:	New requirement to support the Production PSoC 3 device, thus a new 2.0 version was created. Version 1.xx supports PSoC 3 ES2 and PSoC 5 silicon revisions.
	Added configuration of I2C pins connection port for the wakeup on I ² C address match feature.	The I ² C component will be able to wake up the device from Sleep mode on I ² C address match.
	Updated the datasheet.	Updated the Parameters and Setup, Clock Selection, and Resources sections to reflect the UDB Implementation. Error in sample code has been fixed.
	Add Reentrancy support to the component.	Allows users to make specific APIs reentrant if reentrancy is desired.

© Cypress Semiconductor Corporation, 2012-2014. The information contained herein is subject to change without notice. Cypress Semiconductor Corporation assumes no responsibility for the use of any circuitry other than circuitry embodied in a Cypress product. Nor does it convey or imply any license under patent or other rights. Cypress products are not warranted nor intended to be used for medical, life support, life saving, critical control or safety applications, unless pursuant to an express written agreement with Cypress. Furthermore, Cypress does not authorize its products for use as critical components in life-support systems where a malfunction or failure may reasonably be expected to result in significant injury to the user. The inclusion of Cypress products in life-support systems application implies that the manufacturer assumes all risk of such use and in doing so indemnifies Cypress against all charges.

PSoC[®] is a registered trademark, and PSoC Creator™ and Programmable System-on-Chip™ are trademarks of Cypress Semiconductor Corp. All other trademarks or registered trademarks referenced herein are property of the respective corporations.

Any Source Code (software and/or firmware) is owned by Cypress Semiconductor Corporation (Cypress) and is protected by and subject to worldwide patent protection (United States and foreign), United States copyright laws and international treaty provisions. Cypress hereby grants to licensee a personal, non-exclusive, non-transferable license to copy, use, modify, create derivative works of, and compile the Cypress Source Code and derivative works for the sole purpose of creating custom software and or firmware in support of licensee product to be used only in conjunction with a Cypress integrated circuit as specified in the applicable agreement. Any reproduction, modification, translation, compilation, or representation of this Source Code except as specified above is prohibited without the express written permission of Cypress.

Disclaimer: CYPRESS MAKES NO WARRANTY OF ANY KIND, EXPRESS OR IMPLIED, WITH REGARD TO THIS MATERIAL, INCLUDING, BUT NOT LIMITED TO, THE IMPLIED WARRANTIES OF MERCHANTABILITY AND FITNESS FOR A PARTICULAR PURPOSE. Cypress reserves the right to make changes without further notice to the materials described herein. Cypress does not assume any liability arising out of the application or use of any product or circuit described herein. Cypress does not authorize its products for use as critical components in life-support systems where a malfunction or failure may reasonably be expected to result in significant injury to the user. The inclusion of Cypress' product in a life-support systems application implies that the manufacturer assumes all risk of such use and in doing so indemnifies Cypress against all charges.

Use may be limited by and subject to the applicable Cypress software license agreement.

