

CY91460H series is a line of general-purpose 32-bit RISC microcontrollers designed for embedded control applications which require high-speed real-time processing, such as consumer devices and on-board vehicle systems. This series uses the FR60 CPU, which is compatible with the FR family of CPUs.

This series contains the LIN-USART and CAN controllers.

Features

FR60 CPU core

- 32-bit RISC, load/store architecture, five-stage pipeline
- 16-bit fixed-length instructions (basic instructions)
- Instruction execution speed: 1 instruction per cycle
- Instructions including memory-to-memory transfer, bit manipulation, and barrel shift instructions: Instructions suitable for embedded applications
- Function entry/exit instructions and register data multi-load store instructions : Instructions supporting C language
- Register interlock function: Facilitating assembly-language coding
- Built-in multiplier with instruction-level support
 - Signed 32-bit multiplication: 5 cycles
 - Signed 16-bit multiplication: 3 cycles
- Interrupts (save PC/PS) : 6 cycles (16 priority levels)
- Harvard architecture enabling program access and data access to be performed simultaneously
- Instructions compatible with the FR family

Internal peripheral resources

- General-purpose ports : Maximum 108 ports
- DMAC (DMA Controller)
 - Maximum of 5 channels able to operate simultaneously
 - 2 transfer sources (internal peripheral/software)
 - Activation source can be selected using software
 - Addressing mode specifies full 32-bit addresses (increment/decrement/fix)
 - Transfer mode (demand transfer/burst transfer/step transfer/block transfer)
 - Transfer data size selectable from 8/16/32-bit
 - Multi-byte transfer enabled (by software)
 - DMAC descriptor in I/O areas (200_H to 240_H, 1000_H to 1024_H)
- A/D converter (successive approximation type)
 - 10-bit resolution: maximum 32 channels
 - Conversion time: minimum 1 μs
- External interrupt inputs : maximum 16 channels
 - 3 channels shared with CAN RX or I²C pins
- Bit search module (for REALOS)

- Function to search the first bit position of “1”, “0”, “changed” from the MSB (most significant bit) within one word
- LIN-USART (full duplex double buffer): 4 or 7 channels
 - Clock synchronous/asynchronous selectable
 - Sync-break detection
 - Internal dedicated baud rate generator
- I²C bus interface (supports 400 kbps): 2 channels
 - Master/slave transmission and reception
 - Arbitration function, clock synchronization function
- CAN controller (C-CAN): 1 channel
 - Maximum transfer speed: 1 Mbps
 - 32 transmission/reception message buffers
- Sound generator : 1 channel
 - Tone frequency : PWM frequency divide-by-two (reload value + 1)
- Alarm comparator : 1 channel
 - Monitor external voltage
 - Generate an interrupt in case of voltage lower/higher than the defined thresholds (reference voltage)
- 16-bit PPG timer : maximum 16 channels
- 16-bit reload timer: 8 channels
- 16-bit free-run timer: 8 channels (1 channel each for ICU and OCU)
- Input capture: maximum 8 channels (operates in conjunction with the free-run timer)
- Output compare: maximum 8 channels (operates in conjunction with the free-run timer)
- Up/Down counter: 2 channels (2*8-bit or 1*16-bit)
- Watchdog timer
- Real-time clock
- Low-power consumption modes : Sleep/stop mode function
- Low voltage detection circuit
- Clock supervisor
 - Monitors the sub-clock (32 kHz) and the main clock (4 MHz) , and switches to a recovery clock (CR oscillator, etc.) when the oscillations stop.
- Clock modulator
- Clock monitor

- Sub-clock calibration
 - Corrects the real-time clock timer when operating with the 32 kHz or CR oscillator
- Main oscillator stabilization timer
 - Generates an interrupt in sub-clock mode after the stabilization wait time has elapsed on the 23-bit stabilization wait time counter
- Sub-oscillator stabilization timer
 - Generates an interrupt in main clock mode after the stabilization wait time has elapsed on the 15-bit stabilization wait time counter

Package and technology

- Package: QFP-144
- CMOS 180 nm technology
- Power supply range 3 V to 5 V (1.8 V internal logic provided by a step-down voltage converter)
- Operating temperature range: between - 40 °C and + 125 °C

Contents

Product Lineup	4	Embedded Program/Data Memory (Flash)	33
Pin Assignment	6	Flash Features	33
CY91F464HB, CY91F466HA with MD_3 = 1	6	Operation Modes:	33
CY91F464HB, CY91F466HA with MD_3 = 0	7	Flash Access in CPU Mode	34
Pin Description	8	Parallel Flash Programming Mode	37
CY91F464HB, CY91F466HA with MD_3 = 1	8	Poweron Sequence in Parallel Programming Mode	39
CY91F464HB, CY91F466HA with MD_3 = 0	12	Flash Security	39
I/O Circuit Types	17	Memory Space	42
Handling Devices	23	Memory Maps	43
Preventing Latch-up	23	CY91F464HB, CY91F466HA	43
Handling of Unused Input Pins	23	I/O Map	44
Power Supply Pins	23	CY91F464HB, CY91F466HA	44
Crystal Oscillator Circuit	23	Flash Memory and External Bus Area	64
Notes on Using External Clock	23	Interrupt Vector Table	65
Mode Pins (MD_x)	24	Recommended Settings	70
Notes on Operating in PLL Clock Mode	24	PLL and Clockgear Settings	70
Pull-up Control	24	Clock Modulator Settings	71
Notes on Debugger	25	Electrical Characteristics	76
Execution of the RETI Command	25	Absolute Maximum Ratings	76
Break Function	25	Recommended Operating Conditions	79
Operand Break	25	DC Characteristics	80
Notes on PS Register	25	A/D Converter Characteristics	83
Block Diagram	26	Alarm Comparator Characteristics	87
CY91F464HB, CY91F466HA with MD_3 = 1	26	FLASH Memory Program/Erase Characteristics	88
CY91F464HB, CY91F466HA with MD_3 = 0	27	AC Characteristics	89
CPU and Control Unit	28	Ordering Information	101
Features	28	Package Dimension	102
Internal Architecture	28	Revision History	103
Programming Model	29	Major Changes	103
Registers	30	Document History	104
		Sales, Solutions, and Legal Information	105

1. Product Lineup

Feature	CY91FV460B	CY91F464HB	CY91F466HA
Max. core frequency (CLKB)	100 MHz	100 MHz	96 MHz
Max. resource frequency (CLKP)	50 MHz	50 MHz	48 MHz
Max. external bus frequency (CLKT)	50 MHz	50 MHz	48 MHz
Max. CAN frequency (CLKCAN)	50 MHz	50 MHz	48 MHz
Technology	0.18 μ m	0.18 μ m	0.18 μ m
Watchdog	yes	yes	yes
Watchdog (RC osc. based)	yes (disengageable)	yes	yes
Bit Search	yes	yes	yes
Reset input (INITX)	yes	yes	yes
Clock Modulator	yes	yes	yes
Clock Monitor	yes	yes	yes
Low Power Mode	yes	yes	yes
DMA	5 ch	5 ch	5 ch
MMU/MPU	MPU (16 ch) ^{*1}	MPU (8 ch) ^{*1}	MPU (8 ch) ^{*1}
Flash memory	Internal Flash memory 2112 KB + external emulation SRAM with 64 bit read data	416 KByte	832 KByte
Flash Protection	yes	yes	yes
D-RAM	64 KByte	16 KByte	24 KByte
ID-RAM	64 KByte	16 KByte	16 KByte
Flash-Cache (Instruction cache)	16 KByte	8 KByte	8 KByte
Boot-ROM / BI-ROM	16 KByte Boot Flash + 1 KB Boot ROM	4 KByte	4 KByte
RTC	1 ch	1 ch	1 ch
Free Running Timer	12 ch	8 ch ^{*2}	8 ch ^{*2}
ICU	10 ch	MD_3 = 0: 8 ch MD_3 = 1: 4 ch ^{*3}	MD_3 = 0: 8 ch MD_3 = 1: 4 ch ^{*3}
OCU	8 ch	MD_3 = 0: 8 ch MD_3 = 1: 4 ch ^{*4}	MD_3 = 0: 8 ch MD_3 = 1: 4 ch ^{*4}
Reload Timer	16 ch	8 ch ^{*5}	8 ch ^{*5}
PPG 16-bit	32 ch	MD_3 = 0: 16 ch MD_3 = 1: 8 ch ^{*6}	MD_3 = 0: 16 ch MD_3 = 1: 8 ch ^{*6}
Sound Generator	1 ch (old) + 1 ch (new)	1 ch (old)	1 ch (old)
Up/Down Counter (8/16 bit)	4 ch (8-bit) / 2 ch (16-bit)	MD_3 = 0: 2 ch (8-bit) / 1 ch (16-bit) MD_3 = 1: NA ^{*7}	MD_3 = 0: 2 ch (8-bit) / 1 ch (16-bit) MD_3 = 1: NA ^{*7}
C_CAN	6 ch (128 msg)	1 ch (32 msg)	1 ch (32 msg)
LIN-USART	16 ch (FIFO)	MD_3 = 0: 3 ch + 4 ch FIFO ^{*8} MD_3 = 1: 4 ch FIFO	MD_3 = 0: 3 ch + 4 ch FIFO ^{*8} MD_3 = 1: 4 ch FIFO
I ² C (400K)	8 ch	2 ch	2 ch
FR external bus	yes (32 bit addr, 32 bit data)	MD_3 = 0: no MD_3 = 1: yes (22 bit addr, 16 bit data)	MD_3 = 0: no MD_3 = 1: yes (22 bit addr, 16 bit data)

Feature	CY91FV460B	CY91F464HB	CY91F466HA
External Interrupts	32 ch	MD_3 = 0: 16 ch MD_3 = 1: 12 ch ^{*9}	MD_3 = 0: 16 ch MD_3 = 1: 12 ch ^{*9}
NMI Interrupts	1 ch	1 ch	1 ch
ADC (10-bit)	32 ch + 22 ch	MD_3 = 0: 32 ch MD_3 = 1: 16 ch	MD_3 = 0: 32 ch MD_3 = 1: 16 ch
Alarm Comparator	2 ch	1 ch	1 ch
Supply Supervisor (low voltage detection)	yes	yes	yes
Clock Supervisor	yes	yes	yes
Main clock oscillator	4 MHz	4 MHz	4 MHz
Sub clock oscillator	32 kHz	32 kHz	32 kHz
RC oscillator	100 kHz / 2 MHz	100 kHz / 2 MHz	100 kHz / 2 MHz
PLL	x 25	x 25	x 25
DSU4	yes	no	no
EDSU	yes (32 BP) ^{*1}	yes (16 BP) ^{*1}	yes (16 BP) ^{*1}
Supply voltage	1.8 V + 3 V/5 V	3 V/5 V	3 V/5 V
Regulator	no	yes	yes
Power consumption	1.5 W	< 1.3 W	< 1.3 W
Temperature Range (Ta)	0..70 C	-40..125 C	-40..125 C
Package	BGA-896	QFP-144	QFP-144
Power on to PLL run	< 20 ms	< 20 ms	< 20 ms
Flash Download Time	< 8 sec. typical	< 5 sec. typical	< 5 sec. typical

*1. MPU channels use EDSU breakpoint registers (shared operation between MPU and EDSU).

*2. Free Running Timer: MD3 = 0: CH 1 and 0 cannot select external clock (bit7 of TCCS1,0)
MD3 = 1: CH 3, 2, 1, and 0 cannot select external clock (bit7 of TCCS3,2,1,0)

*3. ICU: MD3 = 1: Do not set PFR = 1 & EPFR = 1 (for LIN Synch Field detect).

*4. OCU: MD3 = 1: You cannot use external out-port (but, OCU-function is active.)

*5. Reload Timer: MD3 = 1: CH 7, 6, 5, and 4 cannot select external event

*6. PPG: MD3 = 1: You can use CH15 to 8 of PPG. CH15 to12 cannot select external trigger.

*7. Up/Down Counter: MD3 = 1: You can use Timer-mode only.

*8. LIN-USART CH 0 (shared with external bus) can be used for asynchronous mode only.

*9. External Interrupts: INT7 to INT4 (shared with external bus) can be used for MD3 = 0 mode only. INT0 (shared with external bus) can be used for MD3 = 0 mode only.

2. Pin Assignment

2.1 CY91F464HB, CY91F466HA with MD_3 = 1

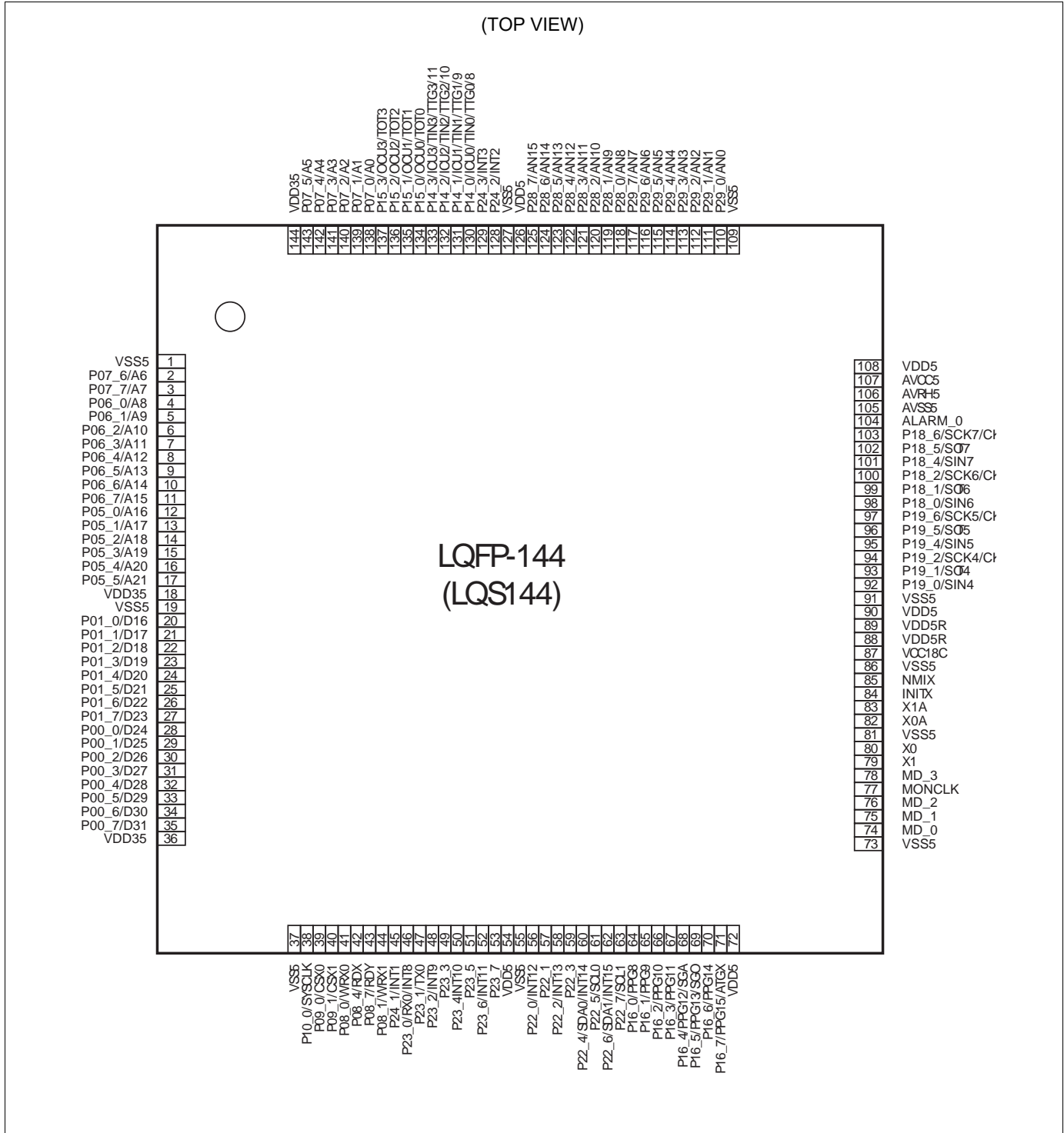

2.2 CY91F464HB, CY91F466HA with MD_3 = 0

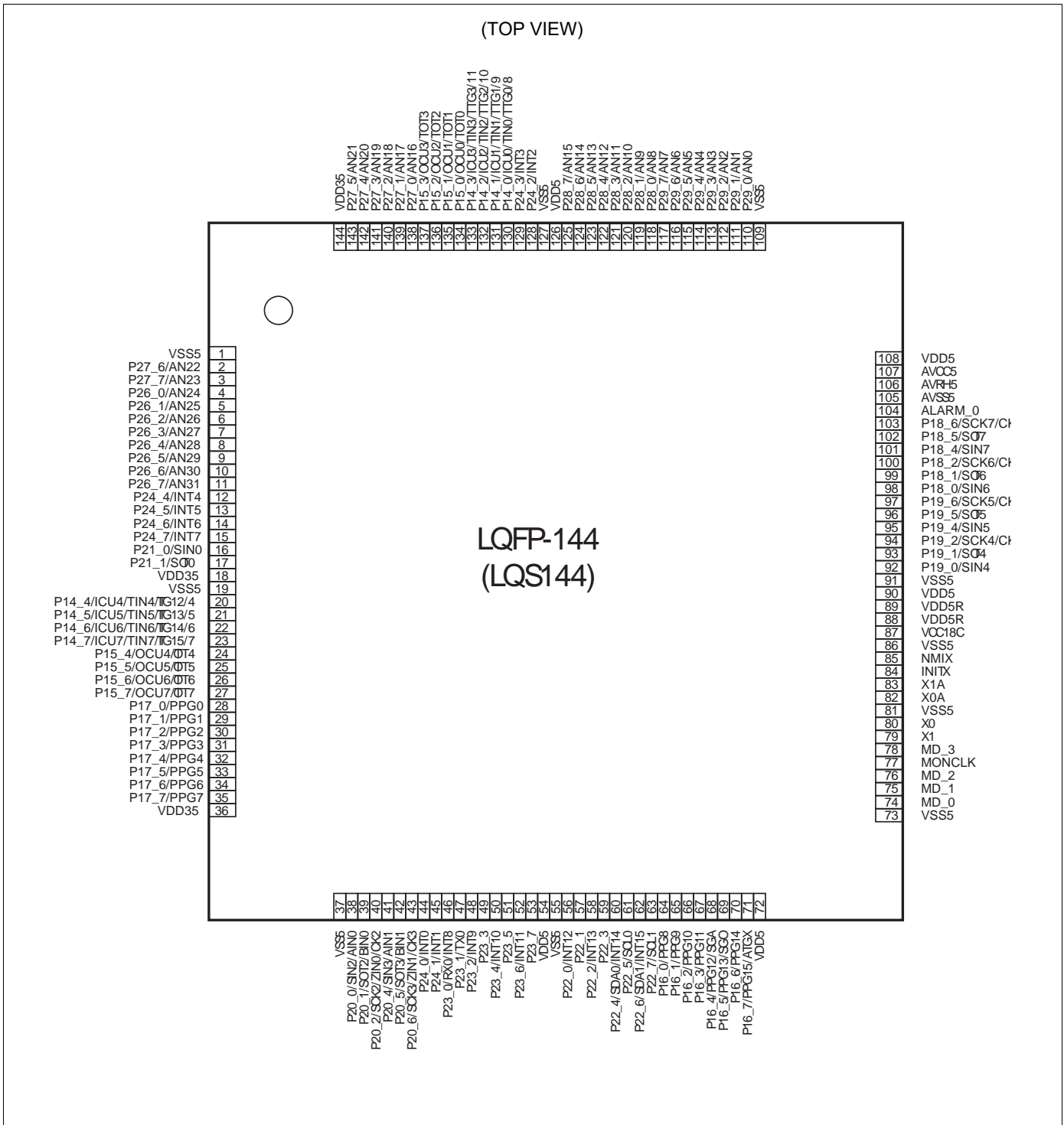

3. Pin Description

3.1 CY91F464HB, CY91F466HA with MD_3 = 1

Pin no.	Pin name	I/O	I/O circuit type*	Function
2, 3	P07_6, P07_7	I/O	B	General-purpose input/output port
	A6, A7			Signal pins of external address bus (bit6 to bit7)
4 to 11	P06_0 to P06_7	I/O	B	General-purpose input/output port
	A8 to A15			Signal pins of external address bus (bit8 to bit15)
12 to 17	P05_0 to P05_5	I/O	A	General-purpose input/output port
	A16 to A21			Signal pins of external address bus (bit16 to bit21)
20 to 27	P01_0 to P01_7	I/O	A	General-purpose input/output port
	D16 to D23			Signal pins of external data bus (bit16 to bit23)
28 to 35	P00_0 to P00_7	I/O	A	General-purpose input/output port
	D24 to D31			Signal pins of external data bus (bit24 to bit31)
38	P10_0	I/O	A	General-purpose input/output port
	SYSCLK			External bus clock output pin
39	P09_0	I/O	A	General-purpose input/output port
	CSX0			Chip select output pins
40	P09_1	I/O	A	General-purpose input/output port
	CSX1			Chip select output pins
41	P08_0	I/O	A	General-purpose input/output port
	WRX0			External write strobe output pins
42	P08_4	I/O	A	General-purpose input/output port
	RDX			External read strobe output pin
43	P08_7	I/O	A	General-purpose input/output port
	RDY			External ready input pin
44	P08_1	I/O	A	General-purpose input/output port
	WRX1			External write strobe output pins
	INT0			External interrupt input, can only be used in general-purpose IO port mode
45	P24_1	I/O	A	General-purpose input/output port
	INT1			External interrupt input pins
46	P23_0	I/O	A	General-purpose input/output port
	RX0			RX input pin of CAN0
	INT8			External interrupt input pins
47	P23_1	I/O	A	General-purpose input/output port
	TX0			TX output pin of CAN0
48	P23_2	I/O	A	General-purpose input/output port
	INT9			External interrupt input pins
49	P23_3	I/O	A	General-purpose input/output port

Pin no.	Pin name	I/O	I/O circuit type*	Function
50	P23_4	I/O	A	General-purpose input/output port
	INT10			External interrupt input pin
51	P23_5	I/O	A	General-purpose input/output port
52	P23_6	I/O	A	General-purpose input/output port
	INT11			External interrupt input pin
53	P23_7	I/O	A	General-purpose input/output port
56	P22_0	I/O	A	General-purpose input/output port
	INT12			External interrupt input pin
57	P22_1	I/O	A	General-purpose input/output port
58	P22_2	I/O	A	General-purpose input/output port
	INT13			External interrupt input pin
59	P22_3	I/O	A	General-purpose input/output port
60	P22_4	I/O	C	General-purpose input/output port
	SDA0			I ² C bus DATA input/output pin (open drain)
	INT14			External interrupt input pin
61	P22_5	I/O	C	General-purpose input/output port
	SCL0			I ² C bus clock input/output pin (open drain)
62	P22_6	I/O	C	General-purpose input/output port
	SDA1			I ² C bus DATA input/output pin (open drain)
	INT15			External interrupt input pin
63	P22_7	I/O	C	General-purpose input/output port
	SCL1			I ² C bus clock input/output pin (open drain)
64	P16_0	I/O	A	General-purpose input/output port
	PPG8			Output pins of PPG timer
65	P16_1	I/O	A	General-purpose input/output port
	PPG9			Output pins of PPG timer
66	P16_2	I/O	A	General-purpose input/output port
	PPG10			Output pins of PPG timer
67	P16_3	I/O	A	General-purpose input/output port
	PPG11			Output pins of PPG timer
68	P16_4	I/O	A	General-purpose input/output port
	PPG12			Output pins of PPG timer
	SGA			SGA output pin of sound generator
69	P16_5	I/O	A	General-purpose input/output port
	PPG13			Output pins of PPG timer
	SGO			SGO output pin of sound generator
70	P16_6	I/O	A	General-purpose input/output port
	PPG14			Output pins of PPG timer

Pin no.	Pin name	I/O	I/O circuit type*	Function
71	P16_7	I/O	A	General-purpose input/output port
	PPG15			Output pins of PPG timer
	ATGX			A/D converter external trigger input pin
74 to 76	MD_0 to MD_2	I	G	Mode setting pins
77	MONCLK	O	M	Clock monitor pin
78	MD_3	I	H	Mode setting pin
79	X1	—	J1	Clock (oscillation) output
80	X0	—	J1	Clock (oscillation) input
82	X0A	—	J2	Sub clock (oscillation) input
83	X1A	—	J2	Sub clock (oscillation) output
84	INITX	I	H	External reset input pin
85	NMIX	I	H	Non-maskable interrupt input pin
92	P19_0	I/O	A	General-purpose input/output port
	SIN4			Data input pin of USART4
93	P19_1	I/O	A	General-purpose input/output port
	SOT4			Data output pin of USART4
94	P19_2	I/O	A	General-purpose input/output port
	SCK4			Clock input/output pin of USART4
	CK4			External clock input pin of free-run timer 4
95	P19_4	I/O	A	General-purpose input/output port
	SIN5			Data input pin of USART5
96	P19_5	I/O	A	General-purpose input/output port
	SOT5			Data output pin of USART5
97	P19_6	I/O	A	General-purpose input/output port
	SCK5			Clock input/output pin of USART5
	CK5			External clock input pin of free-run timer 5
98	P18_0	I/O	A	General-purpose input/output port
	SIN6			Data input pin of USART6
99	P18_1	I/O	A	General-purpose input/output port
	SOT6			Data output pin of USART6
100	P18_2	I/O	A	General-purpose input/output port
	SCK6			Clock input/output pin of USART6
	CK6			External clock input pin of free-run timer 6
101	P18_4	I/O	A	General-purpose input/output port
	SIN7			Data input pin of USART7
102	P18_5	I/O	A	General-purpose input/output port
	SOT7			Data output pin of USART7

Pin no.	Pin name	I/O	I/O circuit type*	Function
103	P18_6	I/O	A	General-purpose input/output port
	SCK7			Clock input/output pin of USART7
	CK7			External clock input pin of free-run timer 7
104	ALARM_0	I	N	Alarm comparator input pin
110 to 117	P29_0 to P29_7	I/O	B	General-purpose input/output port
	AN0 to AN7			Analog input pins of A/D converter
118 to 125	P28_0 to P28_7	I/O	B	General-purpose input/output port
	AN8 to AN15			Analog input pins of A/D converter
128	P24_2	I/O	A	General-purpose input/output port
	INT2			External interrupt input pin
129	P24_3	I/O	A	General-purpose input/output port
	INT3			External interrupt input pin
130 to 133	P14_0 to P14_3	I/O	A	General-purpose input/output port
	ICU0 to ICU3			Input capture input pins
	TIN0 to TIN3			External trigger input pins of reload timer
	TTG0/8 to TTG3/11			External trigger input pins of PPG timer
134 to 137	P15_0 to P15_3	I/O	A	General-purpose input/output port
	OCU0 to OCU3			Output compare output pins
	TOT0 to TOT3			Reload timer output pins
138 to 143	P07_0 to P07_5	I/O	B	General-purpose input/output port
	A0 to A5			Signal pins of external address bus (bit0 to bit5)

[Power supply/Ground pins]

Pin no.	Pin name	I/O	Function
1, 19, 37, 55, 73, 81, 86, 91, 109, 127	VSS5	Supply	Ground pins
54, 72, 90, 108, 126	VDD5		Power supply pins
88, 89	VDD5R		Power supply pins for internal regulator
105	AVSS5		Analog ground pin for A/D converter
107	AVCC5		Power supply pin for A/D converter
106	AVRH5		Reference power supply pin for A/D converter
87	VCC18C		Capacitor connection pin for internal regulator
18, 36, 144	VDD35		Power supply pins for external bus part of I/O ring

3.2 CY91F464HB, CY91F466HA with MD_3 = 0

Pin no.	Pin name	I/O	I/O circuit type*	Function
2 to 3	P27_6 to P27_7	I/O	B	General-purpose input/output ports
	AN22 to AN23			Analog input pins of A/D converter
4 to 11	P26_0 to P26_7	I/O	B	General-purpose input/output ports
	AN24 to AN31			Analog input pins of A/D converter
12 to 15	P24_4 to P24_7	I/O	A	General-purpose input/output ports
	INT4 to INT7			External interrupt input pins
16	P21_0	I/O	A	General-purpose input/output ports
	SIN0			Data input pin of USART0
17	P21_1	I/O	A	General-purpose input/output ports
	SOT0			Data output pin of USART0
20 to 23	P14_4 to P14_7	I/O	A	General-purpose input/output ports
	ICU4 to ICU7			Input capture input pins
	TIN4 to TIN7			External trigger input pins of reload timer
	TTG4/12 to TTG7/15			External trigger input pins of PPG timer
24 to 27	P15_4 to P15_7	I/O	A	General-purpose input/output ports
	OCU4 to OCU7			Output compare output pins
	TOT4 to TOT7			Reload timer output pins
28 to 35	P17_0 to P17_7	I/O	A	General-purpose input/output ports
	PPG0 to PPG7			Output pins of PPG timer
38	P20_0	I/O	A	General-purpose input/output ports
	SIN2			Data input pin of USART2
	AIN0			Up/down counter input pin
39	P20_1	I/O	A	General-purpose input/output ports
	SOT2			Data output pin of USART2
	BIN0			Up/down counter input pin
40	P20_2	I/O	A	General-purpose input/output ports
	SCK2			Clock input/output pin of USART2
	ZIN0			Up/down counter input pin
	CK2			External clock input pin of free-run timer 2
41	P20_4	I/O	A	General-purpose input/output ports
	SIN3			Data input pin of USART3
	AIN1			Up/down counter input pin
42	P20_5	I/O	A	General-purpose input/output ports
	SOT3			Data output pin of USART3
	BIN1			Up/down counter input pin

Pin no.	Pin name	I/O	I/O circuit type*	Function
43	P20_6	I/O	A	General-purpose input/output ports
	SCK3			Clock input/output pin of USART3
	ZIN1			Up/down counter input pin
	CK3			External clock input pin of free-run timer 3
44	P24_0	I/O	A	General-purpose input/output ports
	INT0			External interrupt input pin
45	P24_1	I/O	A	General-purpose input/output ports
	INT1			External interrupt input pin
46	P23_0	I/O	A	General-purpose input/output port
	RX0			RX input pin of CAN0
	INT8			External interrupt input pins
47	P23_1	I/O	A	General-purpose input/output port
	TX0			TX output pin of CAN0
48	P23_2	I/O	A	General-purpose input/output port
	INT9			External interrupt input pins
49	P23_3	I/O	A	General-purpose input/output port
50	P23_4	I/O	A	General-purpose input/output port
	INT10			External interrupt input pin
51	P23_5	I/O	A	General-purpose input/output port
52	P23_6	I/O	A	General-purpose input/output port
	INT11			External interrupt input pin
53	P23_7	I/O	A	General-purpose input/output port
56	P22_0	I/O	A	General-purpose input/output port
	INT12			External interrupt input pin
57	P22_1	I/O	A	General-purpose input/output port
58	P22_2	I/O	A	General-purpose input/output port
	INT13			External interrupt input pin
59	P22_3	I/O	A	General-purpose input/output port
60	P22_4	I/O	C	General-purpose input/output ports
	SDA0			I ² C bus DATA input/output pin (open drain)
	INT14			External interrupt input pin
61	P22_5	I/O	C	General-purpose input/output ports
	SCL0			I ² C bus clock input/output pin (open drain)
62	P22_6	I/O	C	General-purpose input/output ports
	SDA1			I ² C bus DATA input/output pin (open drain)
	INT15			External interrupt input pin
63	P22_7	I/O	C	General-purpose input/output ports
	SCL1			I ² C bus clock input/output pin (open drain)

Pin no.	Pin name	I/O	I/O circuit type*	Function
64 to 67	P16_0 to P16_3	I/O	A	General-purpose input/output ports
	PPG8 to PPG11			Output pins of PPG timer
68	P16_4	I/O	A	General-purpose input/output ports
	PPG12			Output pins of PPG timer
	SGA			SGA output pin of sound generator
69	P16_5	I/O	A	General-purpose input/output ports
	PPG13			Output pins of PPG timer
	SGO			SGO output pin of sound generator
70	P16_6	I/O	A	General-purpose input/output ports
	PPG14			Output pins of PPG timer
71	P16_7	I/O	A	General-purpose input/output ports
	PPG15			Output pins of PPG timer
	ATGX			A/D converter external trigger input pin
74 to 76	MD_0 to MD_2	I	G	Mode setting pins
77	MONCLK	O	M	Clock monitor pin
78	MD_3	I	H	Mode setting pins
79	X1	—	J1	Clock (oscillation) output
80	X0	—	J1	Clock (oscillation) input
82	X0A	—	J2	Sub clock (oscillation) input
83	X1A	—	J2	Sub clock (oscillation) output
84	INITX	I	H	External reset input pin
85	NMIX	I	H	Non-maskable interrupt input pin
92	P19_0	I/O	A	General-purpose input/output ports
	SIN4			Data input pin of USART4
93	P19_1	I/O	A	General-purpose input/output ports
	SOT4			Data output pin of USART4
94	P19_2	I/O	A	General-purpose input/output ports
	SCK4			Clock input/output pin of USART4
	CK4			External clock input pin of free-run timer 4
95	P19_4	I/O	A	General-purpose input/output ports
	SIN5			Data input pin of USART5
96	P19_5	I/O	A	General-purpose input/output ports
	SOT5			Data output pin of USART5
97	P19_6	I/O	A	General-purpose input/output ports
	SCK5			Clock input/output pin of USART5
	CK5			External clock input pin of free-run timer 5
98	P18_0	I/O	A	General-purpose input/output ports
	SIN6			Data input pin of USART6

Pin no.	Pin name	I/O	I/O circuit type*	Function
99	P18_1	I/O	A	General-purpose input/output ports
	SOT6			Data output pin of USART6
100	P18_2	I/O	A	General-purpose input/output ports
	SCK6			Clock input/output pin of USART6
	CK6			External clock input pin of free-run timer 6
101	P18_4	I/O	A	General-purpose input/output ports
	SIN7			Data input pin of USART7
102	P18_5	I/O	A	General-purpose input/output ports
	SOT7			Data output pin of USART7
103	P18_6	I/O	A	General-purpose input/output ports
	SCK7			Clock input/output pin of USART7
	CK7			External clock input pin of free-run timer 7
104	ALARM_0	I	N	Alarm comparator input pin
110 to 117	P29_0 to P29_7	I/O	B	General-purpose input/output ports
	AN0 to AN7			Analog input pins of A/D converter
118 to 125	P28_0 to P28_7	I/O	B	General-purpose input/output ports
	AN8 to AN15			Analog input pins of A/D converter
128	P24_2	I/O	A	General-purpose input/output ports
	INT2			External interrupt input pin
129	P24_3	I/O	A	General-purpose input/output ports
	INT3			External interrupt input pin
130 to 133	P14_0 to P14_3	I/O	A	General-purpose input/output ports
	ICU0 to ICU3			Input capture input pins
	TIN0 to TIN3			External trigger input pins of reload timer
	TTG0/8 to TTG3/11			External trigger input pins of PPG timer
134 to 137	P15_0 to P15_3	I/O	A	General-purpose input/output ports
	OCU0 to OCU3			Output compare output pins
	TOT0 to TOT3			Reload timer output pins
138 to 143	P27_0 to P27_5	I/O	B	General-purpose input/output ports
	AN16 to AN21			Analog input pins of A/D converter

*: For information about the I/O circuit type, refer to 4. "I/O Circuit Types".

[Power supply/Ground pins]

Pin no.	Pin name	I/O	Function
1, 19, 37, 55, 73, 81, 86, 91, 109, 127	VSS5	Supply	Ground pins
54, 72, 90, 108, 126	VDD5		Power supply pins
88, 89	VDD5R		Power supply pins for internal regulator
105	AVSS5		Analog ground pin for A/D converter
107	AVCC5		Power supply pin for A/D converter
106	AVRH5		Reference power supply pin for A/D converter
87	VCC18C		Capacitor connection pin for internal regulator
18, 36, 144	VDD35		Power supply pins for external bus part of I/O ring

*: For information about the I/O circuit type, refer to 4. "I/O Circuit Types".

4. I/O Circuit Types

Type	Circuit	Remarks
A		<p>CMOS level output (programmable $I_{OL} = 5\text{ mA}$, $I_{OH} = -5\text{ mA}$ and $I_{OL} = 2\text{ mA}$, $I_{OH} = -2\text{ mA}$) 2 different CMOS hysteresis inputs with input shutdown function Automotive input with input shutdown function TTL input with input shutdown function Programmable pull-up resistor: 50 kΩ approx.</p>
B		<p>CMOS level output (programmable $I_{OL} = 5\text{ mA}$, $I_{OH} = -5\text{ mA}$ and $I_{OL} = 2\text{ mA}$, $I_{OH} = -2\text{ mA}$) 2 different CMOS hysteresis inputs with input shutdown function Automotive input with input shutdown function TTL input with input shutdown function Programmable pull-up resistor: 50 kΩ approx. Analog input</p>

Type	Circuit	Remarks
C	<p>pull-up control</p> <p>data line</p> <p>pull-down control</p> <p>R</p> <p>CMOS hysteresis type1</p> <p>CMOS hysteresis type2</p> <p>Automotive inputs</p> <p>TTL input</p> <p>standby control for input shutdown</p>	<p>CMOS level output ($I_{OL} = 3\text{ mA}$, $I_{OH} = -3\text{ mA}$)</p> <p>2 different CMOS hysteresis inputs with input shutdown function</p> <p>Automotive input with input shutdown function</p> <p>TTL input with input shutdown function</p> <p>Programmable pull-up resistor: 50 kΩ approx.</p>
D	<p>pull-up control</p> <p>data line</p> <p>pull-down control</p> <p>R</p> <p>CMOS hysteresis type1</p> <p>CMOS hysteresis type2</p> <p>Automotive inputs</p> <p>TTL input</p> <p>standby control for input shutdown</p> <p>analog input</p>	<p>CMOS level output ($I_{OL} = 3\text{ mA}$, $I_{OH} = -3\text{ mA}$)</p> <p>2 different CMOS hysteresis inputs with input shutdown function</p> <p>Automotive input with input shutdown function</p> <p>TTL input with input shutdown function</p> <p>Programmable pull-up resistor: 50 kΩ approx.</p> <p>Analog input</p>

Type	Circuit	Remarks
E	<p>pull-up control</p> <p>driver strength control</p> <p>data line</p> <p>pull-down control</p> <p>R</p> <p>CMOS hysteresis type1</p> <p>CMOS hysteresis type2</p> <p>Automotive inputs</p> <p>TTL input</p> <p>standby control for input shutdown</p>	<p>CMOS level output (programmable $I_{OL} = 5\text{ mA}$, $I_{OH} = -5\text{ mA}$ and $I_{OL} = 2\text{ mA}$, $I_{OH} = -2\text{ mA}$, and $I_{OL} = 30\text{ mA}$, $I_{OH} = -30\text{ mA}$)</p> <p>2 different CMOS hysteresis inputs with input shutdown function</p> <p>Automotive input with input shutdown function</p> <p>TTL input with input shutdown function</p> <p>Programmable pull-up resistor: 50 kΩ approx.</p>
F	<p>pull-up control</p> <p>driver strength control</p> <p>data line</p> <p>pull-down control</p> <p>R</p> <p>CMOS hysteresis type1</p> <p>CMOS hysteresis type2</p> <p>Automotive inputs</p> <p>TTL input</p> <p>standby control for input shutdown</p> <p>analog input</p>	<p>CMOS level output (programmable $I_{OL} = 5\text{ mA}$, $I_{OH} = -5\text{ mA}$ and $I_{OL} = 2\text{ mA}$, $I_{OH} = -2\text{ mA}$, and $I_{OL} = 30\text{ mA}$, $I_{OH} = -30\text{ mA}$)</p> <p>2 different CMOS hysteresis inputs with input shutdown function</p> <p>Automotive input with input shutdown function</p> <p>TTL input with input shutdown function</p> <p>Programmable pull-up resistor: 50 kΩ approx.</p> <p>Analog input</p>

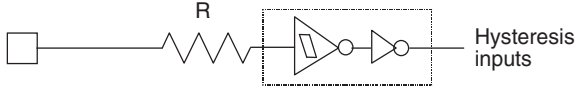
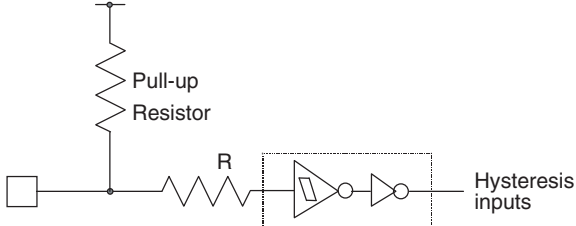
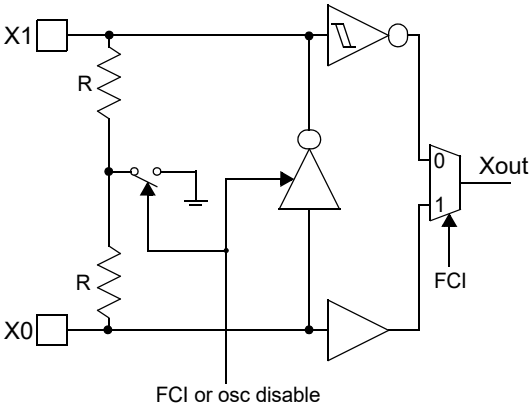
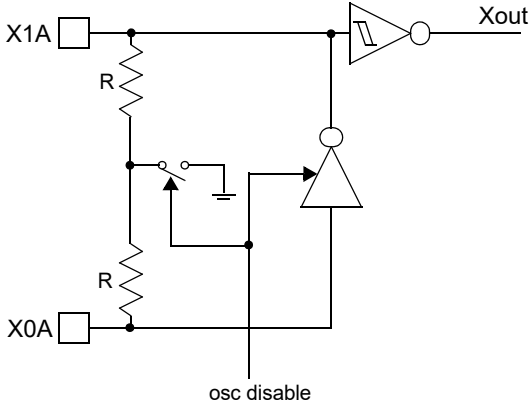
Type	Circuit	Remarks
G		Mask ROM and EVA device: CMOS Hysteresis input pin Flash device: CMOS input pin 12 V withstand (for MD [2:0])
H		CMOS Hysteresis input pin Pull-up resistor value: 50 kΩ approx.
J1		High-speed oscillation circuit: <ul style="list-style-type: none"> • Programmable between oscillation mode (external crystal or resonator connected to X0/X1 pins) and Fast external Clock Input (FCI) mode (external clock connected to X0 pin) • Feedback resistor = approx. 2 * 0.5 MΩ. Feedback resistor is grounded in the center when the oscillator is disabled or in FCI mode.
J2		Low-speed oscillation circuit: <ul style="list-style-type: none"> • Feedback resistor = approx. 2 * 5 MΩ. Feedback resistor is grounded in the center when the oscillator is disabled.

Type	Circuit	Remarks
K	<p>pull-up control</p> <p>driver strength control</p> <p>data line</p> <p>pull-down control</p> <p>R</p> <p>CMOS hysteresis type1</p> <p>CMOS hysteresis type2</p> <p>Automotive inputs</p> <p>TTL input</p> <p>standby control for input shutdown</p> <p>LCD SEG/COM</p>	<p>CMOS level output (programmable $I_{OL} = 5\text{ mA}$, $I_{OH} = -5\text{ mA}$ and $I_{OL} = 2\text{ mA}$, $I_{OH} = -2\text{ mA}$)</p> <p>2 different CMOS hysteresis inputs with input shutdown function</p> <p>Automotive input with input shutdown function</p> <p>TTL input with input shutdown function</p> <p>Programmable pull-up resistor: 50 kΩ approx.</p> <p>LCD SEG/COM output</p>
L	<p>pull-up control</p> <p>driver strength control</p> <p>data line</p> <p>pull-down control</p> <p>R</p> <p>CMOS hysteresis type1</p> <p>CMOS hysteresis type2</p> <p>Automotive inputs</p> <p>TTL input</p> <p>standby control for input shutdown</p> <p>VLCD</p>	<p>CMOS level output (programmable $I_{OL} = 5\text{ mA}$, $I_{OH} = -5\text{ mA}$ and $I_{OL} = 2\text{ mA}$, $I_{OH} = -2\text{ mA}$)</p> <p>2 different CMOS hysteresis inputs with input shutdown function</p> <p>Automotive input with input shutdown function)</p> <p>TTL input with input shutdown function</p> <p>Programmable pull-up resistor: 50 kΩ approx.</p> <p>Analog input</p> <p>LCD Voltage input</p>

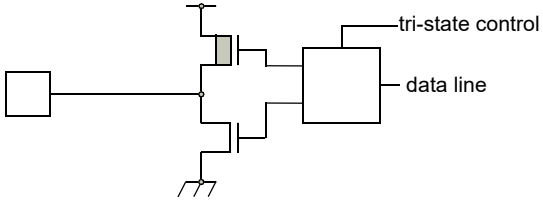
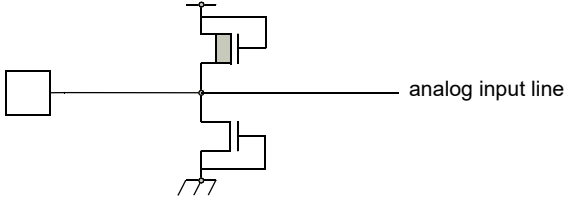
Type	Circuit	Remarks
M		<p>CMOS level tri-state output $(I_{OL} = 5 \text{ mA}, I_{OH} = -5 \text{ mA})$</p>
N		<p>Analog input pin with protection</p>

5. Handling Devices

5.1 Preventing Latch-up

Latch-up may occur in a CMOS IC if a voltage higher than (V_{DD5} , V_{DD35} or HV_{DD5}^{*1}) or less than (V_{SS5} or HV_{SS5}^{*1}) is applied to an input or output pin or if a voltage exceeding the rating is applied between the power supply pins and ground pins. If latch-up occurs, the power supply current increases rapidly, sometimes resulting in thermal breakdown of the device. Therefore, be very careful not to apply voltages in excess of the absolute maximum ratings.

Note *1: HV_{DD5} , HV_{SS5} are available only on devices having Stepper Motor Controller.

5.2 Handling of Unused Input Pins

If unused input pins are left open, abnormal operation may result. Any unused input pins should be connected to pull-up or pull-down resistor (2 k Ω to 10 k Ω) or enable internal pullup or pulldown resistors (PPER/PPCR) before the input enable (PORTEN) is activated by software. The mode pins MD_x can be connected to V_{SS5} or V_{DD5} directly. Unused ALARM input pins can be connected to AV_{SS5} directly.

5.3 Power Supply Pins

In CY91460 series, devices including multiple power supply pins and ground pins are designed as follows; pins necessary to be at the same potential are interconnected internally to prevent malfunctions such as latch-up. All of the power supply pins and ground pins must be externally connected to the power supply and ground respectively in order to reduce unnecessary radiation, to prevent strobe signal malfunctions due to the ground level rising and to follow the total output current ratings. Furthermore, the power supply pins and ground pins of the CY91460 series must be connected to the current supply source via a low impedance.

It is also recommended to connect a ceramic capacitor of approximately 0.1 μ F as a bypass capacitor between power supply pin and ground pin near this device.

This series has a built-in step-down regulator. Connect a bypass capacitor of 4.7 μ F (use a X7R ceramic capacitor) to VCC18C pin for the regulator.

5.4 Crystal Oscillator Circuit

Noise in proximity to the X0 (X0A) and X1 (X1A) pins can cause the device to operate abnormally. Printed circuit boards should be designed so that the X0 (X0A) and X1 (X1A) pins, and crystal oscillator, as well as bypass capacitors connected to ground, are located near the device and ground.

It is recommended that the printed circuit board layout be designed such that the X0 and X1 pins or X0A and X1A pins are surrounded by ground plane for the stable operation.

Please request the oscillator manufacturer to evaluate the oscillational characteristics of the crystal and this device.

5.5 Notes on Using External Clock

When using the external clock, it is necessary to simultaneously supply the X0 (X0A) and the X1 (X1A) pins. In the described combination, X1 (X1A) should be supplied with a clock signal which has the opposite phase to the X0 (X0A) pins. At X0 and X1, a frequency up to 16 MHz is possible.

Example of using opposite phase supply

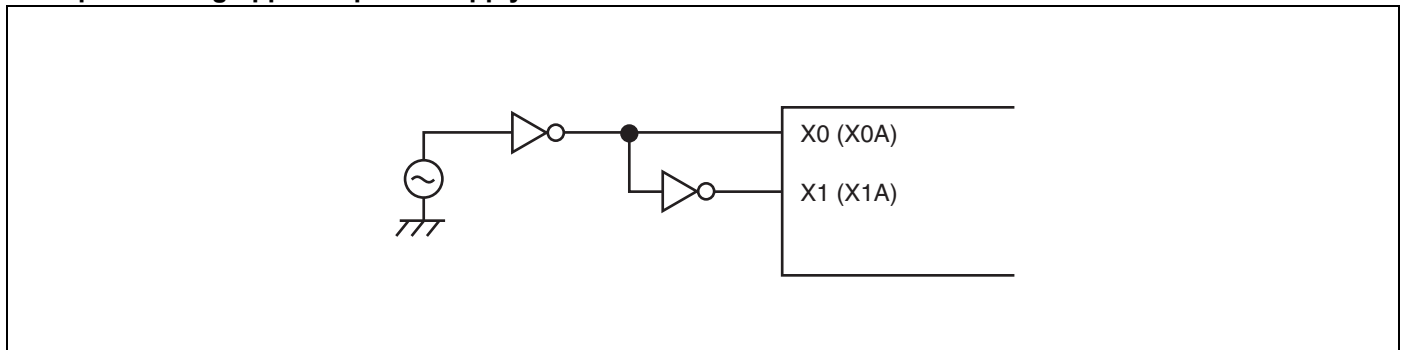

5.6 Mode Pins (MD_x)

These pins should be connected directly to the power supply or ground pins. To prevent the device from entering test mode accidentally due to noise, minimize the lengths of the patterns between each mode pin and power supply pin or ground pin on the printed circuit board as possible and connect them with low impedance.

5.7 Notes on Operating in PLL Clock Mode

If the oscillator is disconnected or the clock input stops when the PLL clock is selected, the microcontroller may continue to operate at the free-running frequency of the self-oscillating circuit of the PLL. However, this self-running operation cannot be guaranteed.

5.8 Pull-up Control

The AC standard is not guaranteed in case a pull-up resistor is connected to the pin serving as an external bus pin.

6. Notes on Debugger

6.1 Execution of the RETI Command

If single-step execution is used in an environment where an interrupt occurs frequently, the corresponding interrupt handling routine will be executed repeatedly to the exclusion of other processing. This will prevent the main routine and the handlers for low priority level interrupts from being executed (For example, if the time-base timer interrupt is enabled, stepping over the RETI instruction will always break on the first line of the time-base timer interrupt handler).

Disable the corresponding interrupts when the corresponding interrupt handling routine no longer needs debugging.

6.2 Break Function

If the range of addresses that cause a hardware break (including event breaks) is set to the address of the current system stack pointer or to an area that contains the stack pointer, execution will break after each instruction regardless of whether the user program actually contains data access instructions.

To prevent this, do not set (word) access to the area containing the address of the system stack pointer as the target of the hardware break (including an event breaks).

6.3 Operand Break

It may cause malfunctions if a stack pointer exists in the area which is set as the DSU operand break. Do not set the access to the areas containing the address of system stack pointer as a target of data event break.

6.4 Notes on PS Register

As the PS register is processed in advance by some instructions, when the debugger is being used, the exception handling may result in execution breaking in an interrupt handling routine or the displayed values of the flags in the PS register being updated.

As the microcontroller is designed to carry out reprocessing correctly upon returning from such an EIT event, the operation before and after the EIT always proceeds according to specification.

The following behavior may occur if any of the following occurs in the instruction immediately after a DIV0U/DIV0S instruction:

- (a) a user interrupt or NMI is accepted;
- (b) single-step execution is performed;
- (c) execution breaks due to a data event or from the emulator menu.
 1. D0 and D1 flags are updated in advance.
 2. An EIT handling routine (user interrupt/NMI or emulator) is executed.
 3. Upon returning from the EIT, the DIV0U/DIV0S instruction is executed and the D0 and D1 flags are updated to the same values as those in 1.

The following behavior occurs when an ORCCR, STILM, MOV Ri,PS instruction is executed to enable a user interrupt or NMI source while that interrupt is in the active state.

1. The PS register is updated in advance.
2. An EIT handling routine (user interrupt/NMI or emulator) is executed.
3. Upon returning from the EIT, the above instructions are executed and the PS register is updated to the same value as in 1.

7. Block Diagram

7.1 CY91F464HB, CY91F466HA with MD_3 = 1

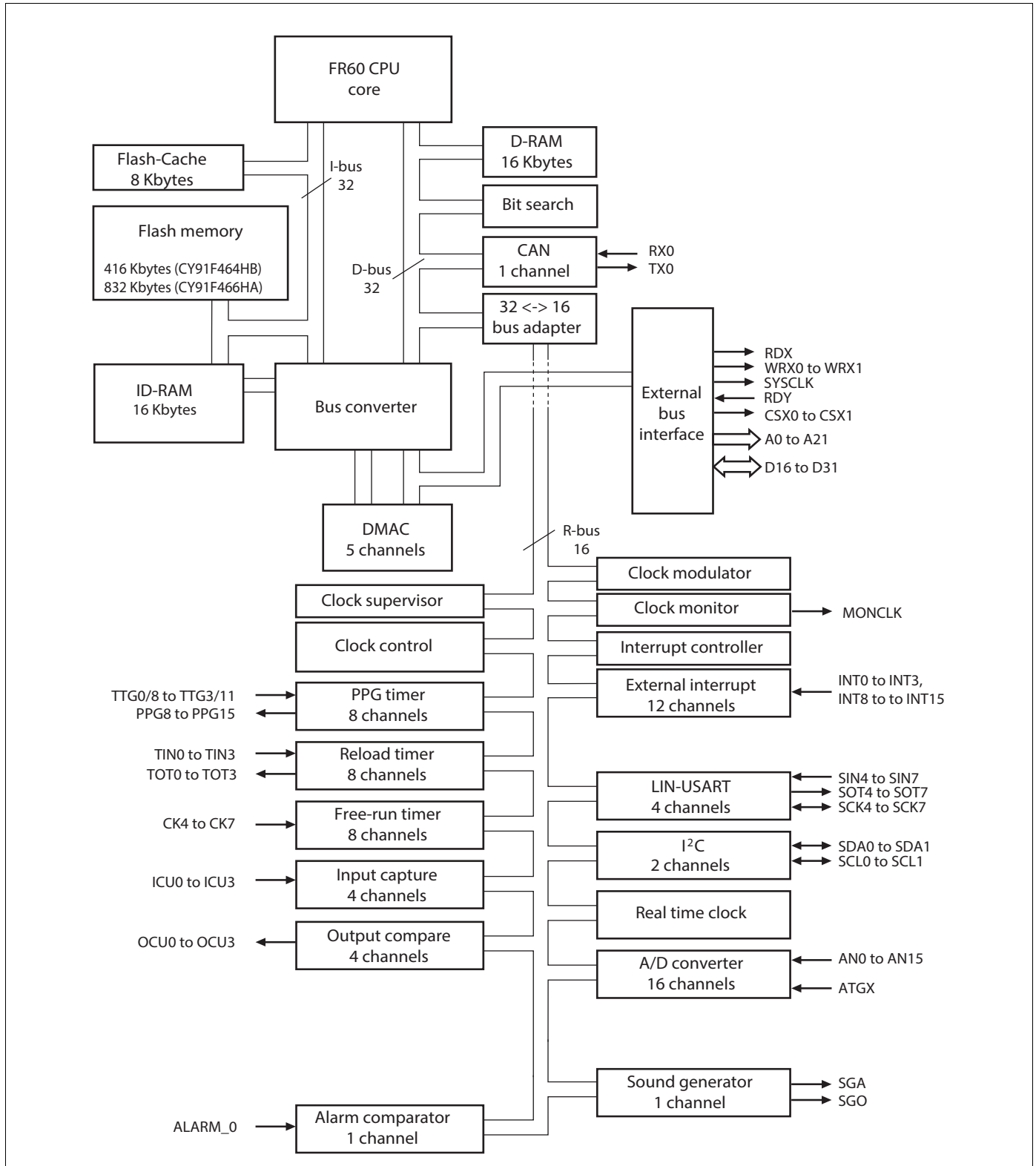

7.2 CY91F464HB, CY91F466HA with MD_3 = 0

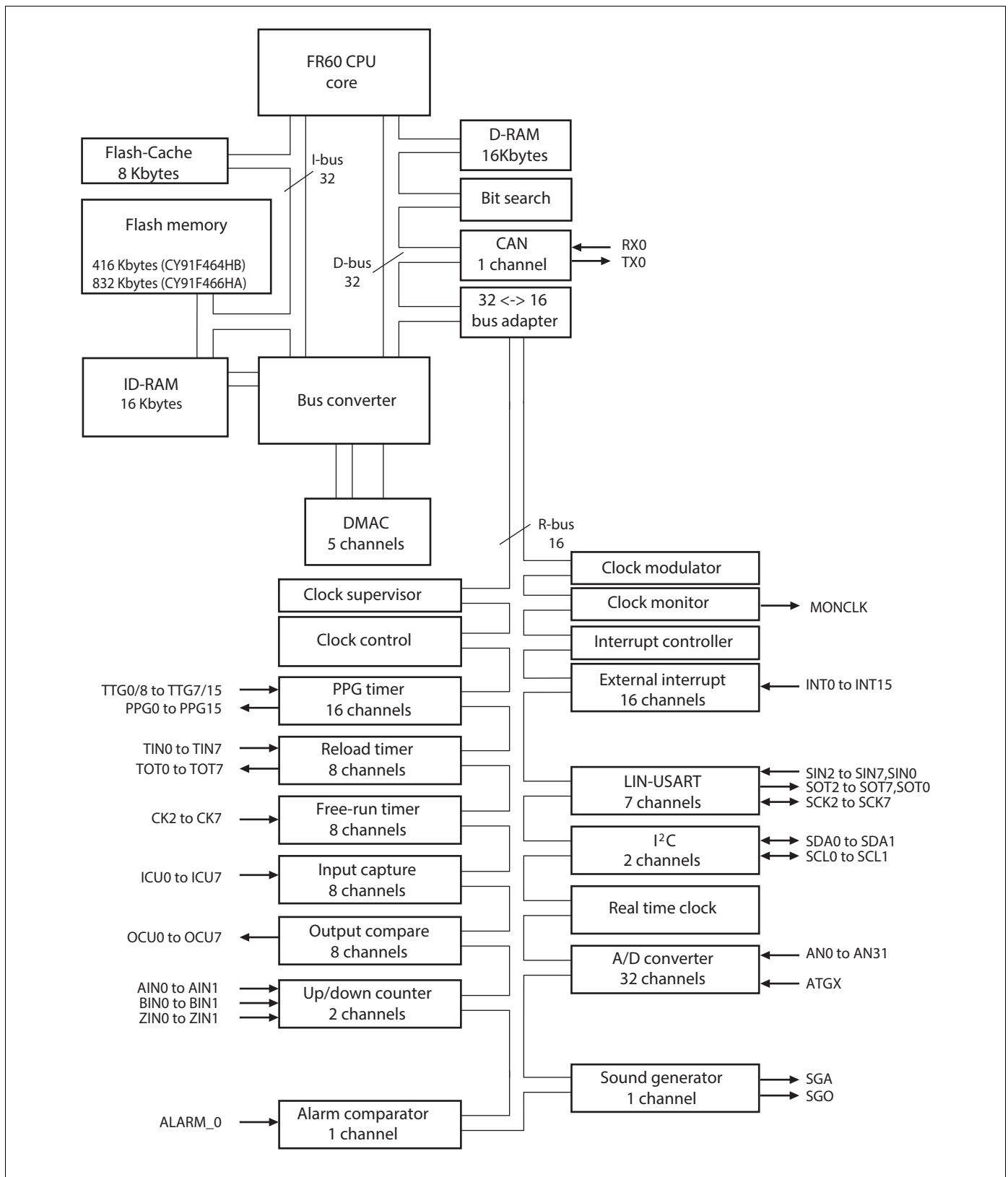

8. CPU and Control Unit

The FR family CPU is a high performance core that is designed based on the RISC architecture with advanced instructions for embedded applications.

8.1 Features

- Adoption of RISC architecture
Basic instruction: 1 instruction per cycle
- General-purpose registers: 32-bit × 16 registers
- 4 Gbytes linear memory space
- Multiplier installed
32-bit × 32-bit multiplication: 5 cycles
16-bit × 16-bit multiplication: 3 cycles
- Enhanced interrupt processing function
Quick response speed (6 cycles)
Multiple-interrupt support
Level mask function (16 levels)
- Enhanced instructions for I/O operation
Memory-to-memory transfer instruction
Bit processing instruction
Basic instruction word length: 16 bits
- Low-power consumption
Sleep mode/stop mode

8.2 Internal Architecture

- The FR family CPU uses the Harvard architecture in which the instruction bus and data bus are independent of each other.
- A 32-bit ↔ 16-bit buffer is connected to the 32-bit bus (D-bus) to provide an interface between the CPU and peripheral resources.
- A Harvard ↔ Princeton bus converter is connected to both the I-bus and D-bus to provide an interface between the CPU and the bus controller.

8.3 Programming Model

8.3.1 Basic Programming Model

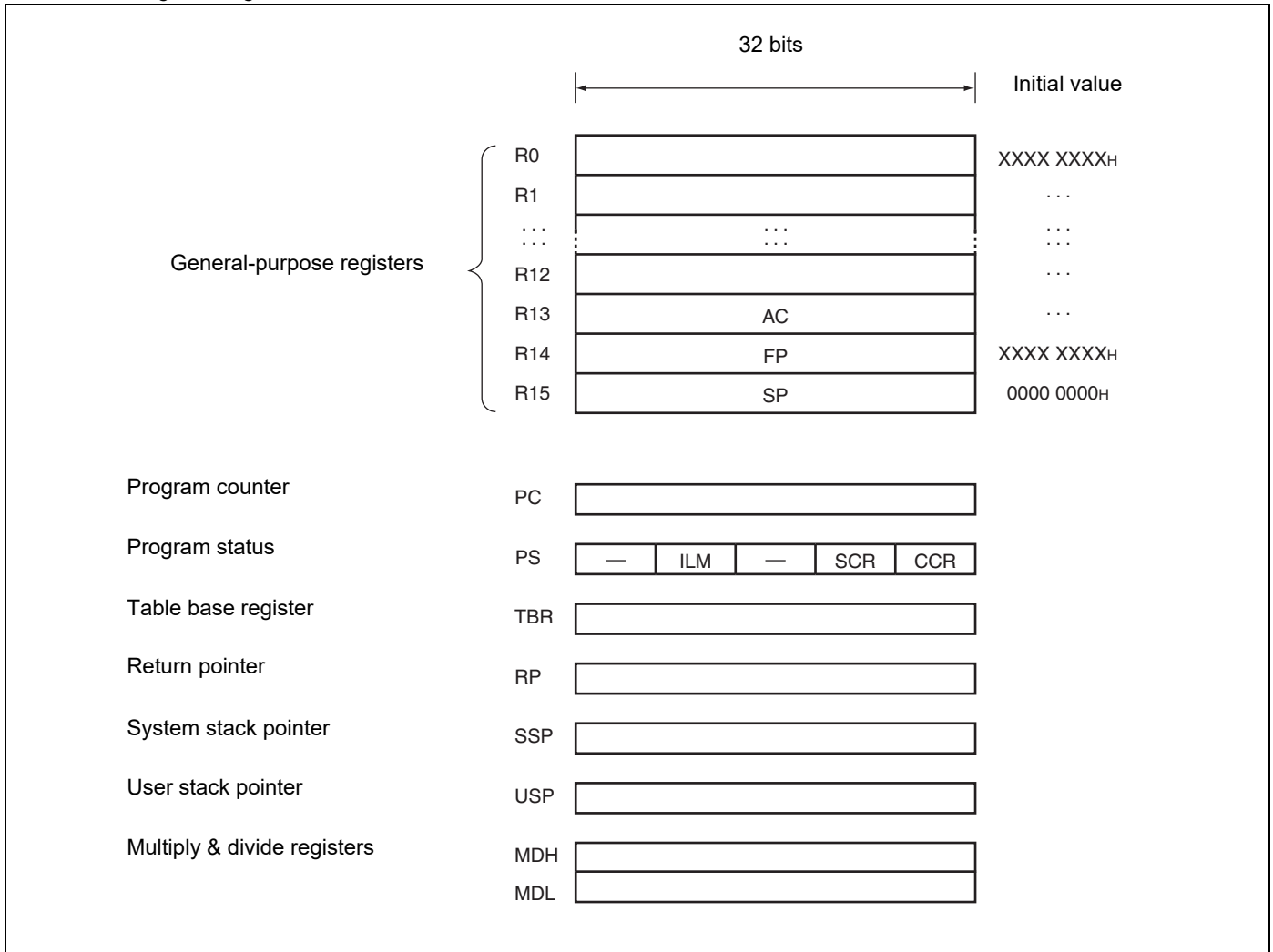

8.4 Registers

8.4.1 General-purpose Register

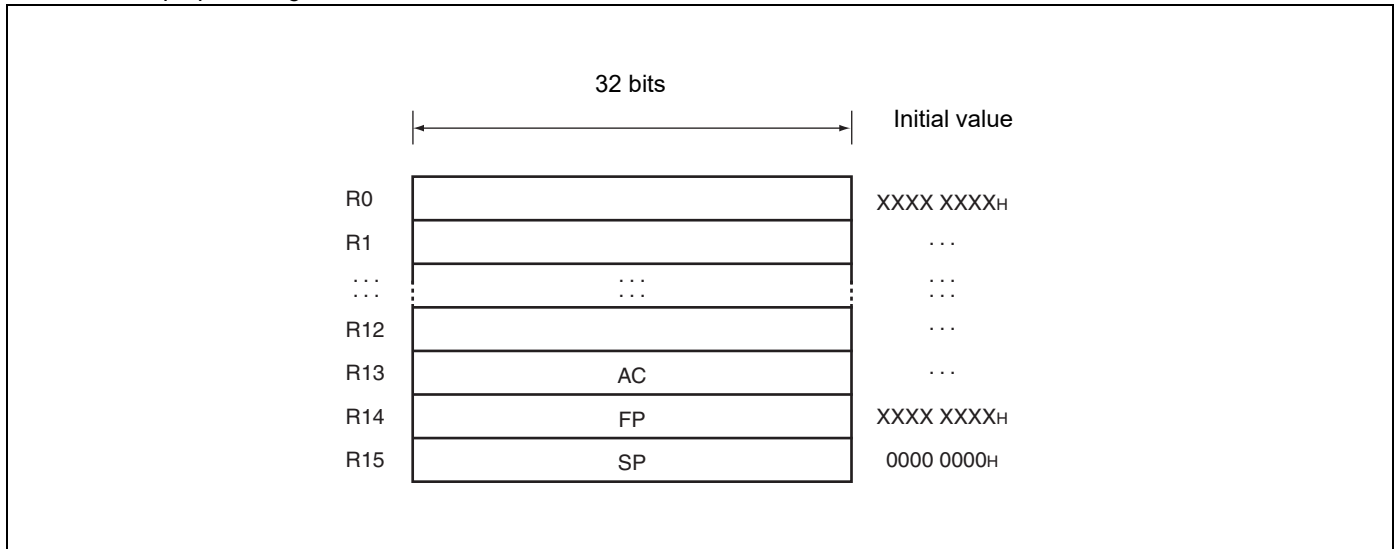

Registers R0 to R15 are general-purpose registers. These registers can be used as accumulators for computation operations and as pointers for memory access.

Of the 16 registers, enhanced commands are provided for the following registers to enable their use for particular applications.

R13: Virtual accumulator

R14: Frame pointer

R15: Stack pointer

Initial values at reset are undefined for R0 to R14. The value for R15 is 00000000_H (SSP value).

8.4.2 PS (Program Status)

This register holds the program status, and is divided into three parts, ILM, SCR, and CCR.

All undefined bits (-) in the diagram are reserved bits. The read values are always "0". Write access to these bits is invalid.

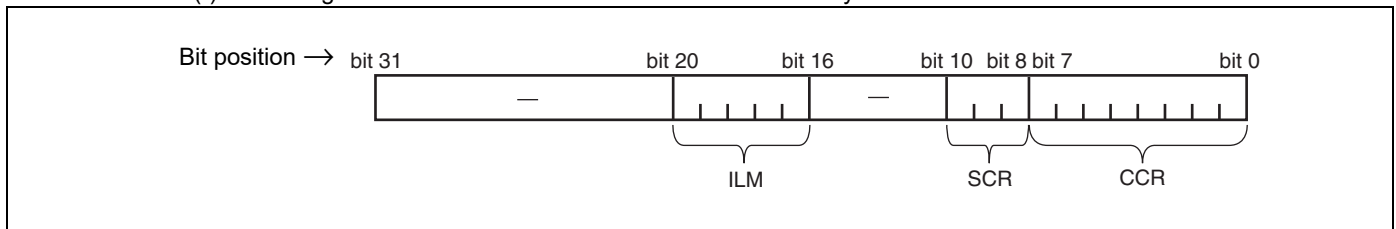

8.4.3 CCR (Condition Code Register)

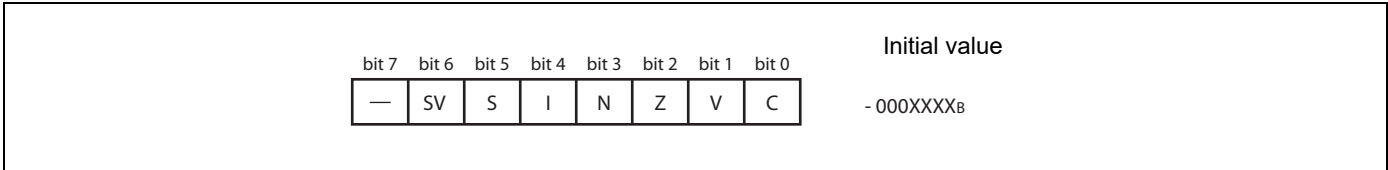

- SV: Supervisor flag
- S: Stack flag
- I: Interrupt enable flag
- N: Negative enable flag
- Z: Zero flag
- V: Overflow flag
- C: Carry flag

8.4.4 SCR (System Condition Register)

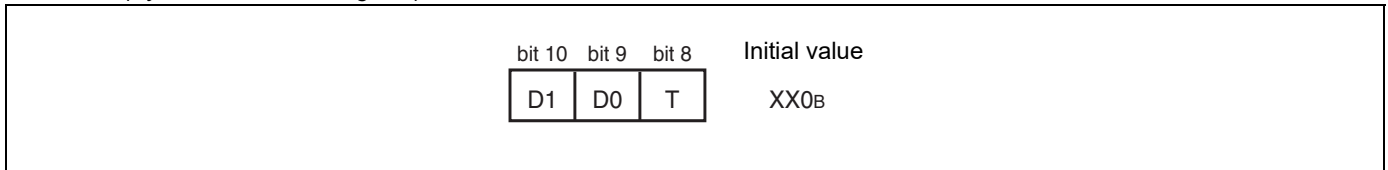

- Flag for step division (D1, D0)
This flag stores interim data during execution of step division.
- Step trace trap flag (T)
This flag indicates whether the step trace trap is enabled or disabled.
The step trace trap function is used by emulators. When an emulator is in use, it cannot be used in execution of user programs.

8.4.5 ILM (Interrupt Level Mask register)

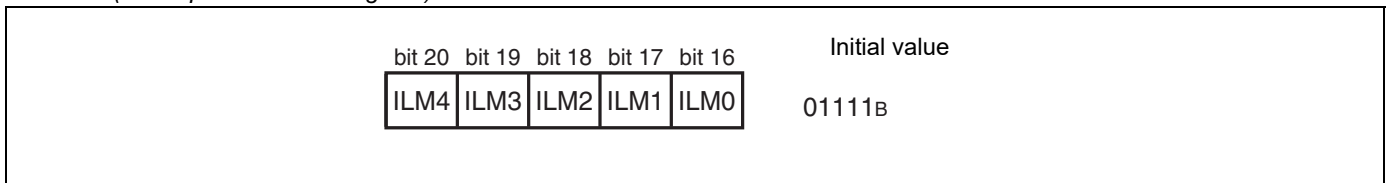

This register stores interrupt level mask values, and the values stored in ILM4 to ILM0 are used for level masking. The register is initialized to value “01111_B” at reset.

8.4.6 PC (Program Counter)

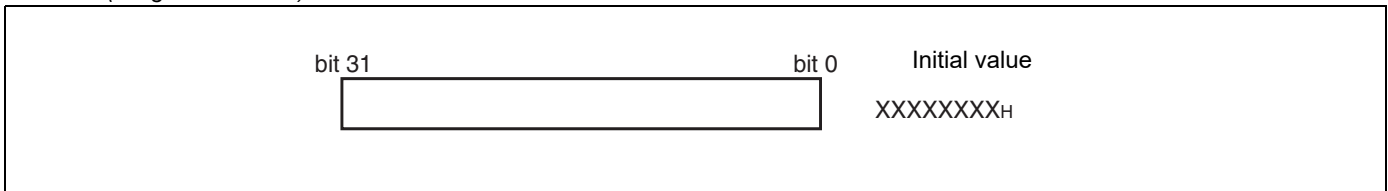

The program counter indicates the address of the instruction that is being executed. The initial value at reset is undefined.

8.4.7 TBR (Table Base Register)

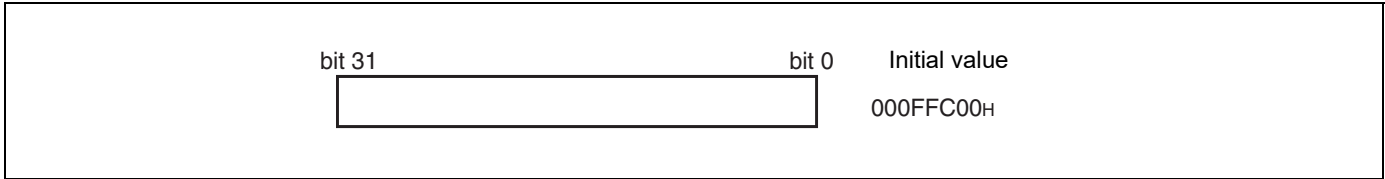

The table base register stores the starting address of the vector table used in EIT processing.
The initial value at reset is 000FFC00_H.

8.4.8 RP (Return Pointer)

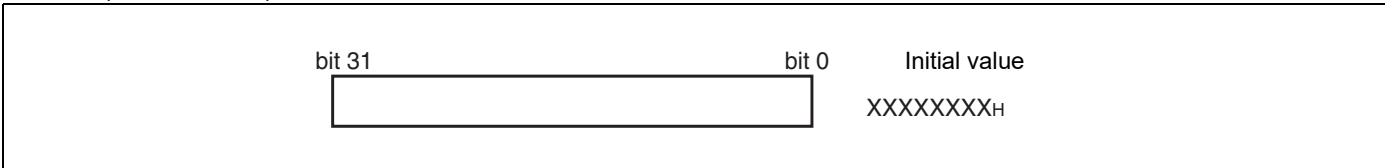

The return pointer stores the address for return from subroutines.
During execution of a CALL instruction, the PC value is transferred to this RP register.
During execution of a RET instruction, the contents of the RP register are transferred to PC.
The initial value at reset is undefined.

8.4.9 USP (User Stack Pointer)

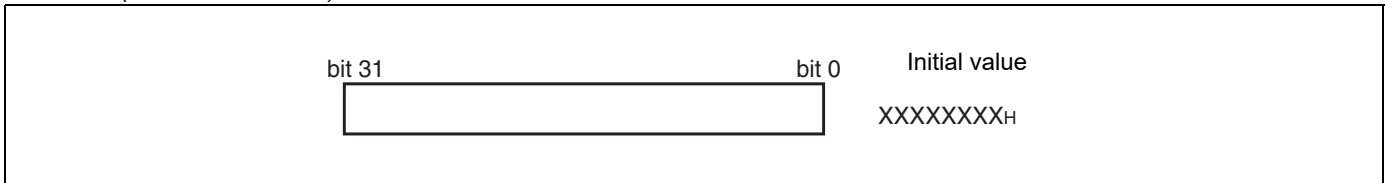

The user stack pointer, when the S flag is "1", this register functions as the R15 register.

- The USP register can also be explicitly specified.
The initial value at reset is undefined.
- This register cannot be used with RETI instructions.

8.4.10 Multiply & Divide Registers

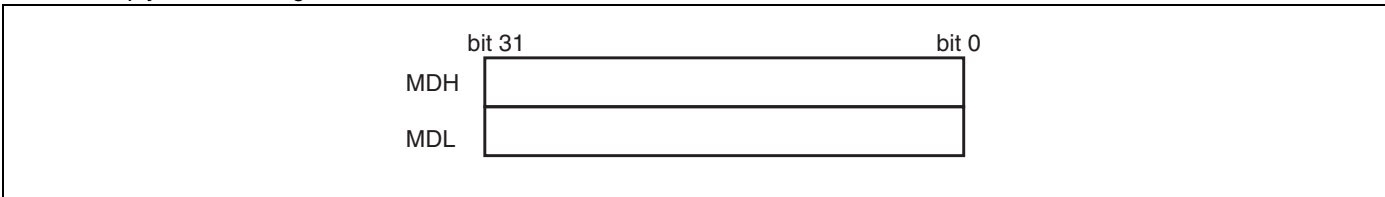

These registers are for multiplication and division, and are each 32 bits in length.
The initial value at reset is undefined.

9. Embedded Program/Data Memory (Flash)

9.1 Flash Features

- CY91F464HB: 416 Kbytes ($6 \times 64 \text{ Kbytes} + 4 \times 8 \text{ Kbytes} = 3.25 \text{ Mbits}$)
- CY91F466HA: 832 Kbytes ($12 \times 64 \text{ Kbytes} + 8 \times 8 \text{ Kbytes} = 6.5 \text{ Mbits}$)
- Programmable wait states for read/write access
- Flash and Boot security with security vector at 0x0014:8000 - 0x0014:800F
- Boot security
- Basic specification: Same as MBM29LV400TC (except size and part of sector configuration)

9.2 Operation Modes:

1. 64-bit CPU mode (available on CY91F466HA only):
 - CPU reads and executes programs in word (32-bit) length units.
 - Flash writing is not possible.
 - Actual Flash Memory access is performed in d-word (64-bit) length units.
2. 32-bit CPU mode:
 - CPU reads and executes programs in word (32-bit) length units.
 - Actual Flash Memory access is performed in word (32-bit) length units.
3. 16-bit CPU mode:
 - CPU reads and writes in half-word (16-bit) length units.
 - Program execution from the Flash is not possible.
 - Actual Flash Memory access is performed in word (16-bit) length units.
4. Flash memory mode (external access to Flash memory enabled)

Note: The operation mode of the flash memory can be selected using a Boot-ROM function. The function start address is 0xBF60. The parameter description is given in the Hardware Manual in chapter 54.6 "Flash Access Mode Switching".

9.3 Flash Access in CPU Mode

9.3.1 Flash Configuration

Flash memory map CY91F464HB, CY91F466HA

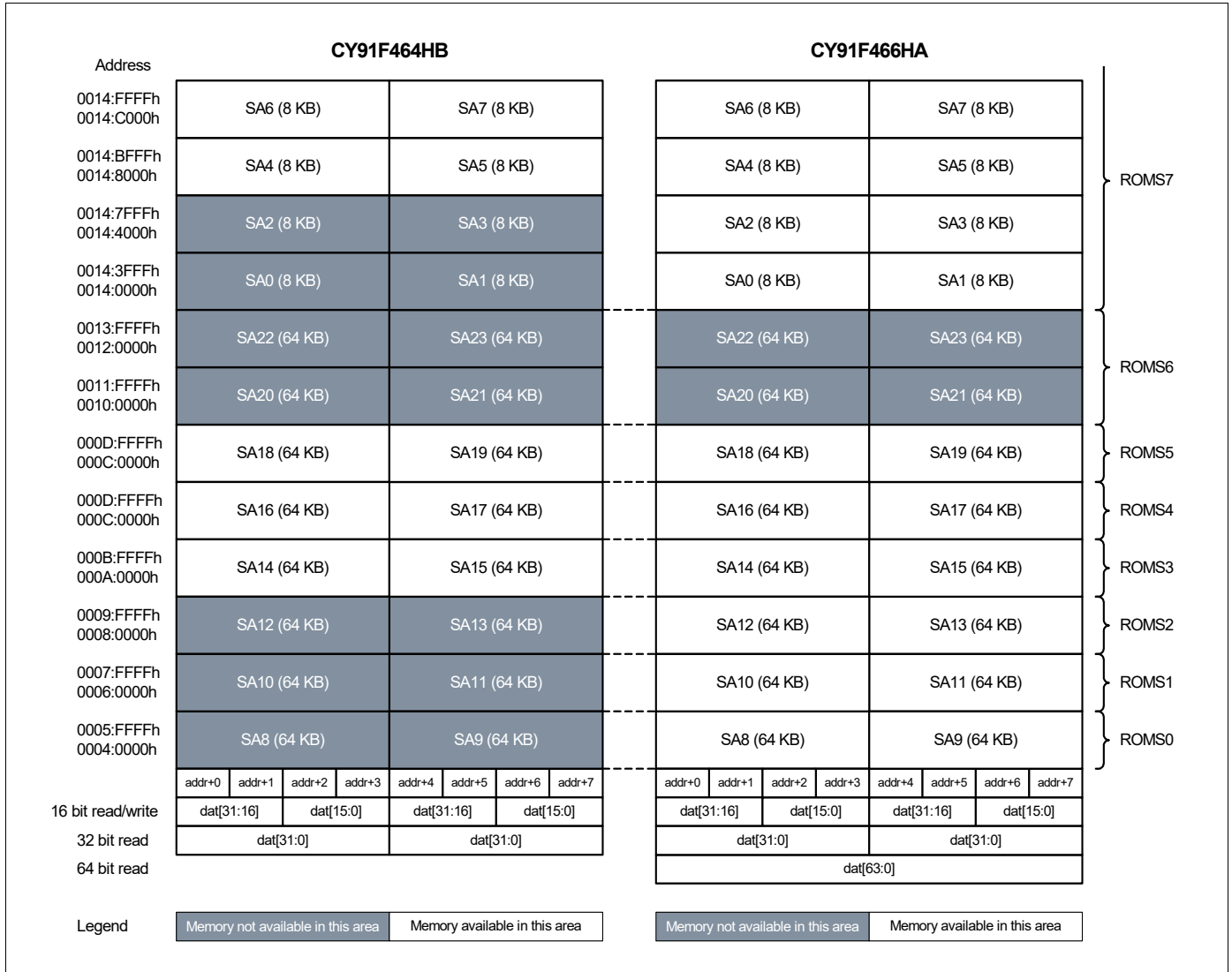

9.3.2 Flash Access Timing Settings in CPU Mode

The following tables list all settings for a given maximum Core Frequency (through the setting of CLKB or maximum clock modulation) for Flash read and write access.

Flash read timing settings (synchronous read)

Core clock (CLKB)	ATD	ALEH	EQ	WEXH	WTC	Remark
to 24 MHz	0	0	0	-	1	
to 48 MHz	0	0	1	-	2	
to 96 MHz	1	1	3	-	4	
to 100 MHz	1	1	3	-	4	not available on CY91F466HA

Flash write timing settings (synchronous write)

Core clock (CLKB)	ATD	ALEH	EQ	WEXH	WTC	Remark
to 16 MHz	0	-	-	0	3	
to 32 MHz	0	-	-	0	4	
to 48 MHz	0	-	-	0	5	
to 64 MHz	1	-	-	0	6	
to 96 MHz	1	-	-	0	7	
to 100 MHz	1	-	-	0	7	not available on CY91F466HA

9.3.3 Address Mapping from CPU to Parallel Programming mode

The following tables show the calculation from CPU addresses to flash macro addresses which are used in parallel programming.

Address mapping CY91F464HB

CPU Address (addr)	Condition	Flash sectors	FA (flash address) Calculation
14:8000h to 14:FFFFh	addr[2]==0	SA4, SA6 (8 Kbyte)	$FA := addr - addr\%00:4000h + (addr\%00:4000h)/2 - (addr/2)\%4 + addr\%4 - 0D:0000h$
14:8000h to 14:FFFFh	addr[2]==1	SA5, SA7 (8 Kbyte)	$FA := addr - addr\%00:4000h + (addr\%00:4000h)/2 + 00:2000h - (addr/2)\%4 + addr\%4 - 0D:0000h$
0A:0000h to 0F:FFFFh	addr[2]==0	SA14, SA16, SA18 (64 Kbyte)	$FA := addr - addr\%02:0000 + (addr\%02:0000h)/2 - (addr/2)\%4 + addr\%4$
0A:0000h to 0F:FFFFh	addr[2]==1	SA15, SA17, SA19 (64 Kbyte)	$FA := addr - addr\%02:0000h + (addr\%02:0000h)/2 + 01:0000h - (addr/2)\%4 + addr\%4$

Note: FA result is without 20:0000h offset for parallel Flash programming.

Set offset by keeping FA[21] = 1 as described in section "Parallel Flash programming mode".

Address mapping CY91F466HA

CPU Address (addr)	Condition	Flash sectors	FA (flash address) Calculation
14:0000h to 14:FFFFh	addr[2]==0	SA0, SA2, SA4, SA6 (8 Kbyte)	$FA := addr - addr\%00:4000h + (addr\%00:4000h)/2 - (addr/2)\%4 + addr\%4 - 05:0000h$
14:0000h to 14:FFFFh	addr[2]==1	SA1, SA3, SA5, SA7 (8 Kbyte)	$FA := addr - addr\%00:4000h + (addr\%00:4000h)/2 + 00:2000h - (addr/2)\%4 + addr\%4 - 05:0000h$
04:0000h to 0F:FFFFh	addr[2]==0	SA8, SA10, SA12, SA14, SA16, SA18 (64 Kbyte)	$FA := addr - addr\%02:0000 + (addr\%02:0000h)/2 - (addr/2)\%4 + addr\%4 + 0C:0000h$
04:0000h to 0F:FFFFh	addr[2]==1	SA9, SA11, SA13, SA15, SA17, SA19 (64 Kbyte)	$FA := addr - addr\%02:0000h + (addr\%02:0000h)/2 + 01:0000h - (addr/2)\%4 + addr\%4 + 0C:0000h$

Note: FA result is without 20:0000h offset for parallel Flash programming.

Set offset by keeping FA[21] = 1 as described in section "Parallel Flash programming mode".

9.4 Parallel Flash Programming Mode

9.4.1 Flash Configuration in Parallel Flash Programming Mode

Parallel Flash programming mode (MD[2:0] = 111)

FA[20:0]	CY91F464HB		FA[21:0]	CY91F466HA	
001F:FFFFh 001F:0000h	SA19 (64 KB)			SA23 (64 KB)	
001E:FFFFh 001E:0000h	SA18 (64 KB)			SA22 (64 KB)	
001D:FFFFh 001D:0000h	SA17 (64 KB)			SA21 (64 KB)	
001C:FFFFh 001C:0000h	SA16 (64 KB)			SA20 (64 KB)	
001B:FFFFh 001B:0000h	SA15 (64 KB)		003B:FFFFh 003B:0000h	SA19 (64 KB)	
001A:FFFFh 001A:0000h	SA14 (64 KB)		003A:FFFFh 003A:0000h	SA18 (64 KB)	
	SA13 (64 KB)		0039:FFFFh 0039:0000h	SA17 (64 KB)	
	SA12 (64 KB)		0038:FFFFh 0038:0000h	SA16 (64 KB)	
	SA11 (64 KB)		0037:FFFFh 0037:0000h	SA15 (64 KB)	
	SA10 (64 KB)		0036:FFFFh 0036:0000h	SA14 (64 KB)	
	SA9 (64 KB)		0035:FFFFh 0035:0000h	SA13 (64 KB)	
	SA8 (64 KB)		0034:FFFFh 0034:0000h	SA12 (64 KB)	
0017:FFFFh 0017:E000h	SA7 (8 KB)		0033:FFFFh 0033:0000h	SA11 (64 KB)	
0017:DFFFh 0017:C000h	SA6 (8 KB)		0032:FFFFh 0032:0000h	SA10 (64 KB)	
0017:BFFFh 0017:A000h	SA5 (8 KB)		0031:FFFFh 0031:0000h	SA9 (64 KB)	
0017:9FFFh 0017:8000h	SA4 (8 KB)		0030:FFFFh 0030:0000h	SA8 (64 KB)	
	SA3 (8 KB)		002F:FFFFh 002F:E000h	SA7 (8 KB)	
	SA2 (8 KB)		002F:DFFFh 002F:C000h	SA6 (8 KB)	
	SA1 (8 KB)		002F:BFFFh 002F:A000h	SA5 (8 KB)	
001C:FFFFh 001C:0000h	SA0 (8 KB)		002F:9FFFh 002F:8000h	SA4 (8 KB)	
	FA[1:0]=00	FA[1:0]=10	002F:7FFFh 002F:6000h	SA3 (8 KB)	
16 bit write mode	DQ[15:0]		002F:5FFFh 002F:4000h	SA2 (8 KB)	
			002F:3FFFh 002F:2000h	SA1 (8 KB)	
			002F:1FFFh 002F:0000h	SA0 (8 KB)	
				FA[1:0]=00	FA[1:0]=10
			16 bit write mode	DQ[15:0]	

Remark: Always keep FA[0] = 0 and FA[20] = 1
Legend
Memory available in this area
Memory not available in this area

9.4.2 Pin connections in Parallel Programming Mode

Resetting after setting the MD[2:0] pins to [111] will halt CPU functioning. At this time, the Flash memory's interface circuit enables direct control of the Flash memory unit from external pins by directly linking some of the signals to GP-Ports. Please see table below for signal mapping.

In this mode, the Flash memory appears to the external pins as a stand-alone unit. This mode is generally set when writing/erasing using the parallel Flash programmer. In this mode, all operations of the 8.5 Mbits Flash memory's Auto Algorithms are available.

Correspondence between MBM29LV400TC and Flash Memory Control Signals

MBM29LV400TC External pins	FR-CPU mode	CY91F464HB, CY91F466HA external pins			Comment
		Flash memory mode	Normal function	Pin number	
-	INITX	-	INITX	84	
RESET	-	FRSTX	P16_6	70	
-	-	MD2	MD2	76	Set to '1'
-	-	MD1	MD1	75	Set to '1'
-	-	MD0	MD0	74	Set to '1'
RY/BY	FMCS:RDY bit	RY/BYX	P18_2	100	
BYTE	Internally fixed to 'H'	BYTEX	P16_4	68	
WE	Internal control signal + control via interface circuit	WEX	P16_7	71	
OE		OEX	P07_7	3	
CE		CEX	P07_6	2	
-		ATDIN	P18_6	103	Set to '0'
-		EQIN	P18_5	102	Set to '0'
-		TESTX	P16_5	69	Set to '1'
-		RDYI	P18_4	101	Set to '0'
A-1		FA0	P05_5	17	Set to '0'
A0 to A3	Internal address bus	FA1 to FA4	P19_0 to P19_2, P19_4	92 to 95	
A4 to A7		FA5 to FA8	P19_5 to P19_6, P18_0 to P18_1	96 to 99	
A8 to A11		FA9 to FA12	P06_0 to P06_3	4 to 7	
A12 to A15		FA13 to FA16	P06_4 to P06_7	8 to 11	
A16 to A18		FA17 to FA19	P05_0 to P05_2	12 to 14	
A19		FA20	P05_3	15	*1
-		FA21	P05_4	16	*2
DQ0 to DQ7		Internal data bus	DQ0 to DQ7	P00_0 to P00_7	28 to 35
DQ8 to DQ15	DQ8 to DQ15		P01_0 to P01_7	20 to 27	

*1. A19 is used as address bit on CY91F466HA. For CY91F464HB, set this pin to '1'.

*2. For CY91F466HA, set this pin to '1'. For CY91F464HB, this pin can be left open.

9.5 Poweron Sequence in Parallel Programming Mode

The flash memory can be accessed in programming mode after a certain wait time, which is needed for Security Vector fetch:

- Minimum wait time after VDD5/VDD5R power on: 2.76 ms
- Minimum wait time after INITX rising: 1.0 ms

9.6 Flash Security

9.6.1 Vector Addresses

Two Flash Security Vectors (FSV1, FSV2) are located parallel to the Boot Security Vectors (BSV1, BSV2) controlling the protection functions of the Flash Security Module:

FSV1: 0x14:8000 BSV1: 0x14:8004
 FSV2: 0x14:8008 BSV2: 0x14:800C

9.6.2 Security Vector FSV1

The setting of the Flash Security Vector FSV1 is responsible for the read and write protection modes and the individual write protection of the 8 KBytes sectors.

9.6.3 FSV1 (bit31 to bit16)

The setting of the Flash Security Vector FSV1 bits [31:16] is responsible for the read and write protection modes.

Explanation of the bits in the Flash Security Vector FSV1[31:16]

FSV1[31:19]	FSV1[18] Write Protection Level	FSV1[17] Write Protection	FSV1[16] Read Protection	Flash Security Mode
set all to '0'	set to '0'	set to '0'	set to '1'	Read Protection (all device modes, except INTVEC mode MD[2:0]="000")
set all to '0'	set to '0'	set to '1'	set to '0'	Write Protection (all device modes, without exception)
set all to '0'	set to '0'	set to '1'	set to '1'	Read Protection (all device modes, except INTVEC mode MD[2:0]="000") and Write Protection (all device modes)
set all to '0'	set to '1'	set to '0'	set to '1'	Read Protection (all device modes, except INTVEC mode MD[2:0]="000")
set all to '0'	set to '1'	set to '1'	set to '0'	Write Protection (all device modes, except INTVEC mode MD[2:0]="000")
set all to '0'	set to '1'	set to '1'	set to '1'	Read Protection (all device modes, except INTVEC mode MD[2:0]="000") and Write Protection (all device modes except INTVEC mode MD[2:0]="000")

FSV1 (bit15 to bit0) CY91F464HB

The setting of the Flash Security Vector FSV1 bits [15:0] is responsible for the individual write protection of the 8 KBytes sectors. It is only evaluated if write protection bit FSV1[17] is set.

Explanation of the bits in the Flash Security Vector FSV1[15:0]

FSV1 bit	Sector	Enable Write Protection	Disable Write Protection	Comment
FSV1[3:0]	—	—	—	not available
FSV1[4]	SA4	set to "0"	—	Write protection is mandatory!
FSV1[5]	SA5	set to "0"	set to "1"	
FSV1[6]	SA6	set to "0"	set to "1"	
FSV1[7]	SA7	set to "0"	set to "1"	
FSV1[15:8]	—	—	—	not available

Note: It is mandatory to always set the sector where the Flash Security Vectors FSV1 and FSV2 are located to write protected (here sector SA4). Otherwise it is possible to overwrite the Security Vector to a setting where it is possible to either read out the Flash content or manipulate data by writing.

See section "Flash access in CPU mode" for an overview about the sector organisation of the Flash Memory.

FSV1 (bit15 to bit0) CY91F466HA

The setting of the Flash Security Vector FSV1 bits [15:0] is responsible for the individual write protection of the 8 KBytes sectors. It is only evaluated if write protection bit FSV1[17] is set.

Explanation of the bits in the Flash Security Vector FSV1[15:0]

FSV1 bit	Sector	Enable Write Protection	Disable Write Protection	Comment
FSV1[0]	SA0	set to "0"	set to "1"	
FSV1[1]	SA1	set to "0"	set to "1"	
FSV1[2]	SA2	set to "0"	set to "1"	
FSV1[3]	SA3	set to "0"	set to "1"	
FSV1[4]	SA4	set to "0"	—	Write protection is mandatory!
FSV1[5]	SA5	set to "0"	set to "1"	
FSV1[6]	SA6	set to "0"	set to "1"	
FSV1[7]	SA7	set to "0"	set to "1"	
FSV1[15:8]	—	—	—	not available

Note: It is mandatory to always set the sector where the Flash Security Vectors FSV1 and FSV2 are located to write protected (here sector SA4). Otherwise it is possible to overwrite the Security Vector to a setting where it is possible to either read out the Flash content or manipulate data by writing.

See section "Flash access in CPU mode" for an overview about the sector organisation of the Flash Memory.

9.6.4 Security Vector FSV2 CY91F464HB

The setting of the Flash Security Vector FSV2 bits [31:0] is responsible for the individual write protection of the 64 KByte sectors. It is only evaluated if write protection bit FSV1[17] is set.

Explanation of the bits in the Flash Security Vector FSV2[31:0]

FSV2 bit	Sector	Enable Write Protection	Disable Write Protection	Comment
FSV2[5:0]	—	—	—	not available
FSV2[6]	SA14	set to "0"	set to "1"	
FSV2[7]	SA15	set to "0"	set to "1"	
FSV2[8]	SA16	set to "0"	set to "1"	
FSV2[9]	SA17	set to "0"	set to "1"	
FSV2[10]	SA18	set to "0"	set to "1"	
FSV2[11]	SA19	set to "0"	set to "1"	
FSV2[31:12]	—	—	—	not available

Note : See section "Flash access in CPU mode" for an overview about the sector organisation of the Flash Memory.

9.6.5 Security Vector FSV2 CY91F466HA

The setting of the Flash Security Vector FSV2 bits [31:0] is responsible for the individual write protection of the 64 KByte sectors. It is only evaluated if write protection bit FSV1[17] is set.

Explanation of the bits in the Flash Security Vector FSV2[31:0]

FSV2 bit	Sector	Enable Write Protection	Disable Write Protection	Comment
FSV2[0]	SA8	set to "0"	set to "1"	
FSV2[1]	SA9	set to "0"	set to "1"	
FSV2[2]	SA10	set to "0"	set to "1"	
FSV2[3]	SA11	set to "0"	set to "1"	
FSV2[4]	SA12	set to "0"	set to "1"	
FSV2[5]	SA13	set to "0"	set to "1"	
FSV2[6]	SA14	set to "0"	set to "1"	
FSV2[7]	SA15	set to "0"	set to "1"	
FSV2[8]	SA16	set to "0"	set to "1"	
FSV2[9]	SA17	set to "0"	set to "1"	
FSV2[10]	SA18	set to "0"	set to "1"	
FSV2[11]	SA19	set to "0"	set to "1"	
FSV2[31:12]	—	—	—	not available

Note : See section "Flash access in CPU mode" for an overview about the sector organisation of the Flash Memory.

10. Memory Space

The FR family has 4 Gbytes of logical address space (2^{32} addresses) available to the CPU by linear access.

Direct addressing area

The following address space area is used for I/O.

This area is called direct addressing area, and the address of an operand can be specified directly in an instruction.

The size of directly addressable area depends on the length of the data being accessed as shown below.

Byte data access : 000_H to 0FF_H

Half word access : 000_H to 1FF_H

Word data access : 000_H to 3FF_H

11. Memory Maps

11.1 CY91F464HB, CY91466HA

CY91F464HB		CY91F466HA	
0000_0000h	I/O (direct addressing area)	0000_0000h	I/O (direct addressing area)
0000_0400h	I/O	0000_0400h	I/O
0000_1000h	DMA	0000_1000h	DMA
0000_2000h	Access prohibited areas	0000_2000h	Access prohibited areas
0000_4000h	Flash-Cache (8 Kbytes)	0000_4000h	Flash-Cache (8 Kbytes)
0000_6000h	Access prohibited areas	0000_6000h	Access prohibited areas
0000_7000h	Flash memory control	0000_7000h	Flash memory control
0000_8000h	Access prohibited areas	0000_8000h	Access prohibited areas
0000_B000h	Boot ROM (4 Kbytes)	0000_B000h	Boot ROM (4 Kbytes)
0000_C000h	CAN	0000_C000h	CAN
0000_D000h	Access prohibited areas	0000_D000h	Access prohibited areas
0002_C000h	D-RAM (0 wait, 16 Kbytes)	0002_A000h	D-RAM (0 wait, 24 Kbytes)
0003_0000h	ID-RAM (16 Kbytes)	0003_0000h	ID-RAM (16 Kbytes)
0003_4000h	Access prohibited areas	0003_4000h	Access prohibited areas
0004_0000h	External bus area	0004_0000h	External bus area
0008_0000h	Access prohibited areas	0008_0000h	Access prohibited areas
000A_0000h	Flash memory (384 Kbytes)	0008_0000h	Flash memory (768 Kbytes)
0010_0000h	External bus area	0010_0000h	Access prohibited areas
0014_8000h	Flash memory (32 Kbytes)	0014_0000h	Flash memory (64 Kbytes)
0015_0000h	Access prohibited areas	0015_0000h	Access prohibited areas
0018_0000h	External bus area	0018_0000h	External bus area
0050_0000h	External data bus	0050_0000h	External data bus
FFFF_FFFFh	Access prohibited areas	FFFF_FFFFh	Access prohibited areas

12. I/O Map

12.1 CY91F464HB, CY91F466HA

Address	Register				Block
	+ 0	+ 1	+ 2	+ 3	
000000 _H	PDR0 [R/W] XXXXXXXX	PDR1 [R/W] XXXXXXXX	PDR2 [R/W] XXXXXXXX	PDR3 [R/W] XXXXXXXX	T-unit port data register

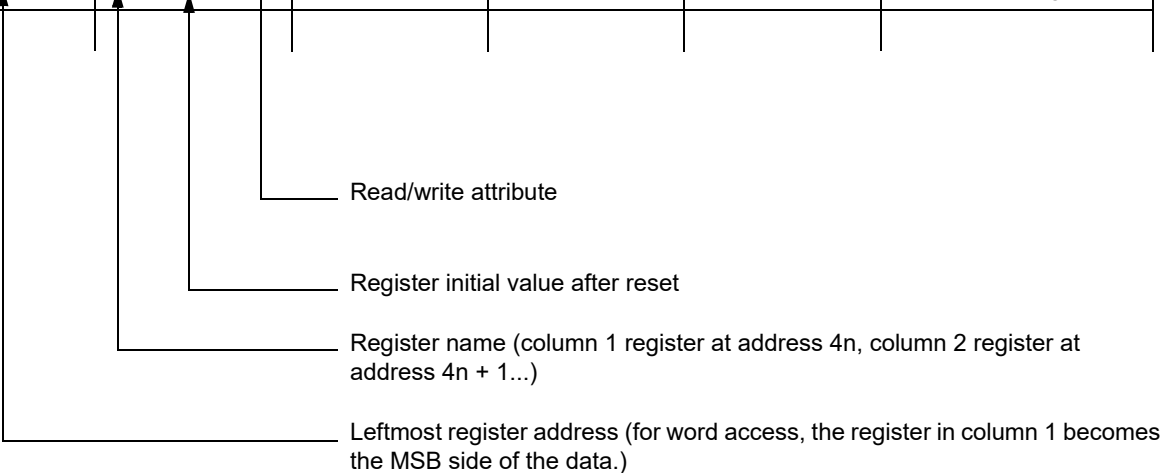

Note : Initial values of register bits are represented as follows:

“ 1 ” : Initial value “ 1 ”

“ 0 ” : Initial value “ 0 ”

“ X ” : Initial value “ undefined ”

“ - ” : No physical register at this location

Access is barred with an undefined data access attribute.

Address	Register				Block
	+0	+1	+2	+3	
000000 _H	PDR00 [R/W] XXXXXXXX	PDR01 [R/W] XXXXXXXX	Reserved	Reserved	R-bus Port Data Register
000004 _H	Reserved	PDR05 [R/W] -- XXXXXX	PDR06 [R/W] XXXXXXXX	PDR07 [R/W] XXXXXXXX	
000008 _H	PDR08 [R/W] X -- X --- X	PDR09 [R/W] ----- XX	PDR10 [R/W] ----- X	Reserved	
00000C _H	Reserved	Reserved	PDR14 [R/W] XXXXXXXX	PDR15 [R/W] XXXXXXXX	
000010 _H	PDR16 [R/W] XXXXXXXX	PDR17 [R/W] XXXXXXXX	PDR18 [R/W] - XXX - XXX	PDR19 [R/W] - XXX - XXX	
000014 _H	PDR20 [R/W] - XXX - XXX	PDR21 [R/W] ----- XX	PDR22 [R/W] XXXXXXXX	PDR23 [R/W] XXXXXXXX	
000018 _H	PDR24 [R/W] XXXXXXXX	Reserved	PDR26 [R/W] XXXXXXXX	PDR27 [R/W] XXXXXXXX	
00001C _H	PDR28 [R/W] XXXXXXXX	PDR29 [R/W] XXXXXXXX	Reserved	Reserved	

Address	Register				Block
	+0	+1	+2	+3	
000020 _H to 00002C _H	Reserved				
000030 _H	EIRR0 [R/W] XXXXXXXX	ENIR0 [R/W] 00000000	ELVR0 [R/W] 00000000 00000000		External interrupt (INT 0 to INT 7)
000034 _H	EIRR1 [R/W] XXXXXXXX	ENIR1 [R/W] 00000000	ELVR1 [R/W] 00000000 00000000		External interrupt (INT 8 to INT 15)
000038 _H	DICR [R/W] ----- 0	HRCL [R/W] 0 - - 11111	RBSYNC		Delay interrupt
00003C _H	Reserved				Reserved
000040 _H	SCR00 [R/W,W] 00000000	SMR00 [R/W,W] 00000000	SSR00 [R/W,R] 00001000	RDR00/TDR00 [R/W] 00000000	LIN-USART 0
000044 _H	ESCR00 [R/W] 00000X00	ECCR00 [R/W,R,W] -00000XX	Reserved		
000048 _H 00004C _H	Reserved				Reserved
000050 _H	SCR02 [R/W,W] 00000000	SMR02 [R/W,W] 00000000	SSR02 [R/W,R] 00001000	RDR02/TDR02 [R/W] 00000000	LIN-USART 2
000054 _H	ESCR02 [R/W] 00000X00	ECCR02 [R/W,R,W] -00000XX	Reserved		
000058 _H	SCR03 [R/W,W] 00000000	SMR03 [R/W,W] 00000000	SSR03 [R/W,R] 00001000	RDR03/TDR03 [R/W] 00000000	LIN-USART 3
00005C _H	ESCR03 [R/W] 00000X00	ECCR03 [R/W,R,W] -00000XX	Reserved		
000060 _H	SCR04 [R/W,W] 00000000	SMR04 [R/W,W] 00000000	SSR04 [R/W,R] 00001000	RDR04/TDR04 [R/W] 00000000	LIN-USART 4 with FIFO
000064 _H	ESCR04 [R/W] 00000X00	ECCR04 [R/W,R,W] -00000XX	FSR04 [R] - - - 00000	FCR04 [R/W] 0001 - 000	
000068 _H	SCR05 [R/W,W] 00000000	SMR05 [R/W,W] 00000000	SSR05 [R/W,R] 00001000	RDR05/TDR05 [R/W] 00000000	LIN-USART 5 with FIFO
00006C _H	ESCR05 [R/W] 00000X00	ECCR05 [R/W,R,W] -00000XX	FSR05 [R] - - - 00000	FCR05 [R/W] 0001 - 000	
000070 _H	SCR06 [R/W,W] 00000000	SMR06 [R/W,W] 00000000	SSR06 [R/W,R] 00001000	RDR06/TDR06 [R/W] 00000000	LIN-USART 6 with FIFO
000074 _H	ESCR06 [R/W] 00000X00	ECCR06 [R/W,R,W] -00000XX	FSR06 [R] - - - 00000	FCR06 [R/W] 0001 - 000	
000078 _H	SCR07 [R/W,W] 00000000	SMR07 [R/W,W] 00000000	SSR07 [R/W,R] 00001000	RDR07/TDR07 [R/W] 00000000	LIN-USART 7 with FIFO
00007C _H	ESCR07 [R/W] 00000X00	ECCR07 [R/W,R,W] -00000XX	FSR07 [R] - - - 00000	FCR07 [R/W] 0001 - 000	

Address	Register				Block
	+0	+1	+2	+3	
000080 _H	BGR100 [R/W] 00000000	BGR000 [R/W] 00000000	Reserved	Reserved	Baud rate Generator LIN-USART 0 to 7
000084 _H	BGR102 [R/W] 00000000	BGR002 [R/W] 00000000	BGR103 [R/W] 00000000	BGR003 [R/W] 00000000	
000088 _H	BGR104 [R/W] 00000000	BGR004 [R/W] 00000000	BGR105 [R/W] 00000000	BGR005 [R/W] 00000000	
00008C _H	BGR106 [R/W] 00000000	BGR006 [R/W] 00000000	BGR107 [R/W] 00000000	BGR007 [R/W] 00000000	
000090 _H to 0000CC _H	Reserved				Reserved
0000D0 _H	IBCR0 [R/W] 00000000	IBSR0 [R] 00000000	ITBAH0 [R/W] ----- 00	ITBAL0 [R/W] 00000000	I ² C 0
0000D4 _H	ITMKH0 [R/W] 00 ---- 11	ITMKL0 [R/W] 11111111	ISMK0 [R/W] 01111111	ISBA0 [R/W] - 00000000	
0000D8 _H	Reserved	IDAR0 [R/W] 00000000	ICCR0 [R/W] - 00111111	Reserved	
0000DC _H	IBCR1 [R/W] 00000000	IBSR1 [R] 00000000	ITBAH1 [R/W] ----- 00	ITBAL1 [R/W] 00000000	I ² C 1
0000E0 _H	ITMKH1 [R/W] 00 ---- 11	ITMKL1 [R/W] 11111111	ISMK1 [R/W] 01111111	ISBA1 [R/W] - 00000000	
0000E4 _H	Reserved	IDAR1 [R/W] 00000000	ICCR1 [R/W] - 00111111	Reserved	
0000E8 _H to 0000FC _H	Reserved				Reserved
000100 _H	GCN10 [R/W] 00110010 00010000		Reserved	GCN20 [R/W] ---- 0000	PPG Control 0 to 3
000104 _H	GCN11 [R/W] 00110010 00010000		Reserved	GCN21 [R/W] ---- 0000	PPG Control 4 to 7
000108 _H	GCN12 [R/W] 00110010 00010000		Reserved	GCN22 [R/W] ---- 0000	PPG Control 8 to 11
000110 _H	PTMR00 [R] 11111111 11111111		PCSR00 [W] XXXXXXXX XXXXXXXX		PPG 0
000114 _H	PDUT00 [W] XXXXXXXX XXXXXXXX		PCNH00 [R/W] 0000000 -	PCNL00 [R/W] 000000 - 0	
000118 _H	PTMR01 [R] 11111111 11111111		PCSR01 [W] XXXXXXXX XXXXXXXX		PPG 1
00011C _H	PDUT01 [W] XXXXXXXX XXXXXXXX		PCNH01 [R/W] 0000000 -	PCNL01 [R/W] 000000 - 0	
000120 _H	PTMR02 [R] 11111111 11111111		PCSR02 [W] XXXXXXXX XXXXXXXX		PPG 2
000124 _H	PDUT02 [W] XXXXXXXX XXXXXXXX		PCNH02 [R/W] 0000000 -	PCNL02 [R/W] 000000 - 0	

Address	Register				Block
	+0	+1	+2	+3	
000128 _H	PTMR03 [R] 11111111 11111111		PCSR03 [W] XXXXXXXX XXXXXXXX		PPG 3
00012C _H	PDUT03 [W] XXXXXXXX XXXXXXXX		PCNH03 [R/W] 0000000 -	PCNL03 [R/W] 000000 - 0	
000130 _H	PTMR04 [R] 11111111 11111111		PCSR04 [W] XXXXXXXX XXXXXXXX		PPG 4
000134 _H	PDUT04 [W] XXXXXXXX XXXXXXXX		PCNH04 [R/W] 0000000 -	PCNL04 [R/W] 000000 - 0	
000138 _H	PTMR05 [R] 11111111 11111111		PCSR05 [W] XXXXXXXX XXXXXXXX		PPG 5
00013C _H	PDUT05 [W] XXXXXXXX XXXXXXXX		PCNH05 [R/W] 0000000 -	PCNL05 [R/W] 000000 - 0	
000140 _H	PTMR06 [R] 11111111 11111111		PCSR06 [W] XXXXXXXX XXXXXXXX		PPG 6
000144 _H	PDUT06 [W] XXXXXXXX XXXXXXXX		PCNH06 [R/W] 0000000 -	PCNL06 [R/W] 000000 - 0	
000148 _H	PTMR07 [R] 11111111 11111111		PCSR07 [W] XXXXXXXX XXXXXXXX		PPG 7
00014C _H	PDUT07 [W] XXXXXXXX XXXXXXXX		PCNH07 [R/W] 0000000 -	PCNL07 [R/W] 000000 - 0	
000150 _H	PTMR08 [R] 11111111 11111111		PCSR08 [W] XXXXXXXX XXXXXXXX		PPG 8
000154 _H	PDUT08 [W] XXXXXXXX XXXXXXXX		PCNH08 [R/W] 0000000 -	PCNL08 [R/W] 000000 - 0	
000158 _H	PTMR09 [R] 11111111 11111111		PCSR09 [W] XXXXXXXX XXXXXXXX		PPG 9
00015C _H	PDUT09 [W] XXXXXXXX XXXXXXXX		PCNH09 [R/W] 0000000 -	PCNL09 [R/W] 000000 - 0	
000160 _H	PTMR10 [R] 11111111 11111111		PCSR10 [W] XXXXXXXX XXXXXXXX		PPG 10
000164 _H	PDUT10 [W] XXXXXXXX XXXXXXXX		PCNH10 [R/W] 0000000 -	PCNL10 [R/W] 000000 - 0	
000168 _H	PTMR11 [R] 11111111 11111111		PCSR11 [W] XXXXXXXX XXXXXXXX		PPG 11
00016C _H	PDUT11 [W] XXXXXXXX XXXXXXXX		PCNH11 [R/W] 0000000 -	PCNL11 [R/W] 000000 - 0	
000170 _H to 00017C _H	Reserved				Reserved
000180 _H	Reserved	ICS01 [R/W] 00000000	Reserved	ICS23 [R/W] 00000000	Input Capture 0 to 3
000184 _H	IPCP0 [R] XXXXXXXX XXXXXXXX		IPCP1 [R] XXXXXXXX XXXXXXXX		
000188 _H	IPCP2 [R] XXXXXXXX XXXXXXXX		IPCP3 [R] XXXXXXXX XXXXXXXX		

Address	Register				Block
	+0	+1	+2	+3	
00018C _H	OCS01 [R/W] --- 0 -- 00 0000 -- 00		OCS23 [R/W] --- 0 -- 00 0000 -- 00		Output Compare 0 to 3
000190 _H	OCCP0 [R/W] XXXXXXXX XXXXXXXX		OCCP1 [R/W] XXXXXXXX XXXXXXXX		
000194 _H	OCCP2 [R/W] XXXXXXXX XXXXXXXX		OCCP3 [R/W] XXXXXXXX XXXXXXXX		
000198 _H	SGCRH [R/W] 0000 -- 00	SGCRL [R/W] -- 0 -- 000	SGFR [R/W, R] XXXXXXXX XXXXXXXX		Sound Generator
00019C _H	SGAR [R/W] 00000000	Reserved	SGTR [R/W] XXXXXXXX	SGDR [R/W] XXXXXXXX	
0001A0 _H	ADERH [R/W] 00000000 00000000		ADERL [R/W] 00000000 00000000		A/D Converter
0001A4	ADCS1 [R/W] 00000000	ADCS0 [R/W] 00000000	ADCR1 [R] 000000XX	ADCR0 [R] XXXXXXXX	
0001A8 _H	ADCT1 [R/W] 00010000	ADCT0 [R/W] 00101100	ADSCH [R/W] --- 00000	ADECH [R/W] --- 00000	
0001AC _H	Reserved	ACSR0 [R/W] -11XXX00	Reserved	Reserved	Alarm Comparator 0 to 1
0001B0 _H	TMRLR0 [W] XXXXXXXX XXXXXXXX		TMR0 [R] XXXXXXXX XXXXXXXX		Reload Timer 0 (PPG 0, PPG 1)
0001B4 _H	Reserved		TMCSRH0 [R/W] --- 00000	TMCSRL0 [R/W] 0 - 000000	
0001B8 _H	TMRLR1 [W] XXXXXXXX XXXXXXXX		TMR1 [R] XXXXXXXX XXXXXXXX		Reload Timer 1 (PPG 2, PPG 3)
0001BC _H	Reserved		TMCSRH1 [R/W] --- 00000	TMCSRL1 [R/W] 0 - 000000	
0001C0 _H	TMRLR2 [W] XXXXXXXX XXXXXXXX		TMR2 [R] XXXXXXXX XXXXXXXX		Reload Timer 2 (PPG 4, PPG 5)
0001C4 _H	Reserved		TMCSRH2 [R/W] --- 00000	TMCSRL2 [R/W] 0 - 000000	
0001C8 _H	TMRLR3 [W] XXXXXXXX XXXXXXXX		TMR3 [R] XXXXXXXX XXXXXXXX		Reload Timer 3 (PPG 6, PPG 7)
0001CC _H	Reserved		TMCSRH3 [R/W] --- 00000	TMCSRL3 [R/W] 0 - 000000	
0001D0 _H	TMRLR4 [W] XXXXXXXX XXXXXXXX		TMR4 [R] XXXXXXXX XXXXXXXX		Reload Timer 4 (PPG 8, PPG 9)
0001D4 _H	Reserved		TMCSRH4 [R/W] --- 00000	TMCSRL4 [R/W] 0 - 000000	

Address	Register				Block
	+0	+1	+2	+3	
0001D8 _H	TMRLR5 [W] XXXXXXXX XXXXXXXX		TMR5 [R] XXXXXXXX XXXXXXXX		Reload Timer 5 (PPG 10, PPG 11)
0001DC _H	Reserved		TMCSRH5 [R/W] --- 00000	TMCSRL5 [R/W] 0 - 000000	
0001E0 _H	TMRLR6 [W] XXXXXXXX XXXXXXXX		TMR6 [R] XXXXXXXX XXXXXXXX		Reload Timer 6 (PPG 12, PPG 13)
0001E4 _H	Reserved		TMCSRH6 [R/W] --- 00000	TMCSRL6 [R/W] 0 - 000000	
0001E8 _H	TMRLR7 [W] XXXXXXXX XXXXXXXX		TMR7 [R] XXXXXXXX XXXXXXXX		Reload Timer 7 (PPG 14, PPG 15) (A/D Converter)
0001EC _H	Reserved		TMCSRH7 [R/W] --- 00000	TMCSRL7 [R/W] 0 - 000000	
0001F0 _H	TCDT0 [R/W] XXXXXXXX XXXXXXXX		Reserved	TCCS0 [R/W] 00000000	Free Running Timer 0 (ICU 0, ICU 1)
0001F4 _H	TCDT1 [R/W] XXXXXXXX XXXXXXXX		Reserved	TCCS1 [R/W] 00000000	Free Running Timer 1 (ICU 2, ICU 3)
0001F8 _H	TCDT2 [R/W] XXXXXXXX XXXXXXXX		Reserved	TCCS2 [R/W] 00000000	Free Running Timer 2 (OCU 0, OCU 1)
0001FC _H	TCDT3 [R/W] XXXXXXXX XXXXXXXX		Reserved	TCCS3 [R/W] 00000000	Free Running Timer 3 (OCU 2, OCU 3)
000200 _H	DMACA0 [R/W] 00000000 0000XXXX XXXXXXXX XXXXXXXX				DMAC
000204 _H	DMACB0 [R/W] 00000000 00000000 XXXXXXXX XXXXXXXX				
000208 _H	DMACA1 [R/W] 00000000 0000XXXX XXXXXXXX XXXXXXXX				
00020C _H	DMACB1 [R/W] 00000000 00000000 XXXXXXXX XXXXXXXX				
000210 _H	DMACA2 [R/W] 00000000 0000XXXX XXXXXXXX XXXXXXXX				
000214 _H	DMACB2 [R/W] 00000000 00000000 XXXXXXXX XXXXXXXX				
000218 _H	DMACA3 [R/W] 00000000 0000XXXX XXXXXXXX XXXXXXXX				
00021C _H	DMACB3 [R/W] 00000000 00000000 XXXXXXXX XXXXXXXX				

Address	Register				Block
	+0	+1	+2	+3	
000220 _H	DMACA4 [R/W] 00000000 0000XXXX XXXXXXXX XXXXXXXX				DMAC
000224 _H	DMACB4 [R/W] 00000000 00000000 XXXXXXXX XXXXXXXX				
000228 _H to 00023C _H	Reserved				
000240 _H	DMACR [R/W] 00 - - 0000	Reserved			
000244 _H to 0002CC _H	Reserved				Reserved
0002D0 _H	Reserved	ICS045 [R/W] 00000000	Reserved	ICS67 [R/W] 00000000	Input Capture 4 to 7
0002D4 _H	IPCP4 [R] XXXXXXXX XXXXXXXX		IPCP5 [R] XXXXXXXX XXXXXXXX		
0002D8 _H	IPCP6 [R] XXXXXXXX XXXXXXXX		IPCP7 [R] XXXXXXXX XXXXXXXX		
0002DC _H	OCS45 [R/W] --- 0 -- 00 0000 -- 00		OCS67 [R/W] --- 0 -- 00 0000 -- 00		Output Compare 4 to 7
0002E0 _H	OCCP4 [R/W] XXXXXXXX XXXXXXXX		OCCP5 [R/W] XXXXXXXX XXXXXXXX		
0002E4 _H	OCCP6 [R/W] XXXXXXXX XXXXXXXX		OCCP7 [R/W] XXXXXXXX XXXXXXXX		
0002E8 _H to 0002EC _H	Reserved				Reserved
0002F0 _H	TCDT4 [R/W] XXXXXXXX XXXXXXXX		Reserved	TCCS4 [R/W] 00000000	Free Running Timer 4 (ICU 4, ICU 5)
0002F4 _H	TCDT5 [R/W] XXXXXXXX XXXXXXXX		Reserved	TCCS5 [R/W] 00000000	Free Running Timer 5 (ICU 6, ICU 7)
0002F8 _H	TCDT6 [R/W] XXXXXXXX XXXXXXXX		Reserved	TCCS6 [R/W] 00000000	Free Running Timer 6 (OCU 4, OCU 5)
0002FC _H	TCDT7 [R/W] XXXXXXXX XXXXXXXX		Reserved	TCCS7 [R/W] 00000000	Free Running Timer 7 (OCU 6, OCU 7)
000300 _H	UDRC1 [W] 00000000	UDRC0 [W] 00000000	UDCR1 [R] 00000000	UDCR0 [R] 00000000	Up/Down Counter 0 to 1
000304 _H	UDCCH0 [R/W] 00000000	UDCCL0 [R/W] 00001000	Reserved	UDCS0 [R/W] 00000000	
000308 _H	UDCCH1 [R/W] 00000000	UDCCL1 [R/W] 00001000	Reserved	UDCS1 [R/W] 00000000	
00030C _H to 00031C _H	Reserved				Reserved

Address	Register				Block
	+0	+1	+2	+3	
000320 _H	GCN13 [R/W] 00110010 00010000		Reserved	GCN23 [R/W] ---- 0000	PPG Control 12 to 15
000324 _H to 00032C _H	Reserved				Reserved
000330 _H	PTMR12 [R] 11111111 11111111		PCSR12 [W] XXXXXXXX XXXXXXXX		PPG 12
000334 _H	PDUT12 [W] XXXXXXXX XXXXXXXX		PCNH12 [R/W] 0000000 -	PCNL12 [R/W] 000000 - 0	
000338 _H	PTMR13 [R] 11111111 11111111		PCSR13 [W] XXXXXXXX XXXXXXXX		PPG 13
00033C _H	PDUT13 [W] XXXXXXXX XXXXXXXX		PCNH13 [R/W] 0000000 -	PCNL13 [R/W] 000000 - 0	
000340 _H	PTMR14 [R] 11111111 11111111		PCSR14 [W] XXXXXXXX XXXXXXXX		PPG 14
000344 _H	PDUT14 [W] XXXXXXXX XXXXXXXX		PCNH14 [R/W] 0000000 -	PCNL14 [R/W] 000000 - 0	
000348 _H	PTMR15 [R] 11111111 11111111		PCSR15 [W] XXXXXXXX XXXXXXXX		PPG 15
00034C _H	PDUT15 [W] XXXXXXXX XXXXXXXX		PCNH15 [R/W] 0000000 -	PCNL15 [R/W] 000000 - 0	
000350 _H to 00038C _H	Reserved				Reserved
000390 _H	ROMS [R] 11111111 01000011		Reserved		ROM Select Register
000394 _H to 0003EC _H	Reserved				Reserved
0003F0 _H	BSD0 [W] XXXXXXXX XXXXXXXX XXXXXXXX XXXXXXXX				Bit Search Module
0003F4 _H	BSD1 [R/W] XXXXXXXX XXXXXXXX XXXXXXXX XXXXXXXX				
0003F8 _H	BSDC [W] XXXXXXXX XXXXXXXX XXXXXXXX XXXXXXXX				
0003FC _H	BSRR [R] XXXXXXXX XXXXXXXX XXXXXXXX XXXXXXXX				
000400 _H to 00043C _H	Reserved				

Address	Register				Block
	+0	+1	+2	+3	
000440 _H	ICR00 [R/W] ---11111	ICR01 [R/W] ---11111	ICR02 [R/W] ---11111	ICR03 [R/W] ---11111	Interrupt Controller
000444 _H	ICR04 [R/W] ---11111	ICR05 [R/W] ---11111	ICR06 [R/W] ---11111	ICR07 [R/W] ---11111	
000448 _H	ICR08 [R/W] ---11111	ICR09 [R/W] ---11111	ICR10 [R/W] ---11111	ICR11 [R/W] ---11111	
00044C _H	ICR12 [R/W] ---11111	ICR13 [R/W] ---11111	ICR14 [R/W] ---11111	ICR15 [R/W] ---11111	
000450 _H	ICR16 [R/W] ---11111	ICR17 [R/W] ---11111	ICR18 [R/W] ---11111	ICR19 [R/W] ---11111	
000454 _H	ICR20 [R/W] ---11111	ICR21 [R/W] ---11111	ICR22 [R/W] ---11111	ICR23 [R/W] ---11111	
000458 _H	ICR24 [R/W] ---11111	ICR25 [R/W] ---11111	ICR26 [R/W] ---11111	ICR27 [R/W] ---11111	
00045C _H	ICR28 [R/W] ---11111	ICR29 [R/W] ---11111	ICR30 [R/W] ---11111	ICR31 [R/W] ---11111	
000460 _H	ICR32 [R/W] ---11111	ICR33 [R/W] ---11111	ICR34 [R/W] ---11111	ICR35 [R/W] ---11111	
000464 _H	ICR36 [R/W] ---11111	ICR37 [R/W] ---11111	ICR38 [R/W] ---11111	ICR39 [R/W] ---11111	
000468 _H	ICR40 [R/W] ---11111	ICR41 [R/W] ---11111	ICR42 [R/W] ---11111	ICR43 [R/W] ---11111	
00046C _H	ICR44 [R/W] ---11111	ICR45 [R/W] ---11111	ICR46 [R/W] ---11111	ICR47 [R/W] ---11111	
000470 _H	ICR48 [R/W] ---11111	ICR49 [R/W] ---11111	ICR50 [R/W] ---11111	ICR51 [R/W] ---11111	
000474 _H	ICR52 [R/W] ---11111	ICR53 [R/W] ---11111	ICR54 [R/W] ---11111	ICR55 [R/W] ---11111	
000478 _H	ICR56 [R/W] ---11111	ICR57 [R/W] ---11111	ICR58 [R/W] ---11111	ICR59 [R/W] ---11111	
00047C _H	ICR60 [R/W] ---11111	ICR61 [R/W] ---11111	ICR62 [R/W] ---11111	ICR63 [R/W] ---11111	Interrupt Controller
000480 _H	RSRR [R/W] 10000000	STCR [R/W] 00110011	TBCR [R/W] 00XXXX00	CTBR [W] XXXXXXXXXX	Clock Control
000484 _H	CLKR [R/W] ---- 0000	WPR [W] XXXXXXXXXX	DIVR0 [R/W] 00000011	DIVR1 [R/W] 00000000	
000488 _H	Reserved				Reserved
00048C _H	PLLDIVM [R/W] ---- 0000	PLLDIVN [R/W] -- 000000	PLLDIVG [R/W] ---- 0000	PLLMULG [R/W] 00000000	PLL Interface
000490 _H	PLLCTRL [R/W] ---- 0000	Reserved			
000494 _H	OSCC1 [R/W] ----- 010	OSCS1 [R/W] 00001111	OSCC2 [R/W] ----- 010	OSCS2 [R/W] 00001111	Main/Sub Oscillator Control (Reserved)

Address	Register				Block
	+0	+1	+2	+3	
000498 _H	PORTEN [R/W] ----- 00	Reserved			Port Input Enable Control
0004A0 _H	Reserved	WTCER [R/W] ----- 00	WTCR [R/W] 00000000 000 - 00 - 0		Real Time Clock (Watch Timer)
0004A4 _H	Reserved	WTBR [R/W] --- XXXXX XXXXXXXXX XXXXXXXXX			
0004A8 _H	WTHR [R/W] --- 00000	WTMR [R/W] -- 000000	WTSR [R/W] -- 000000	Reserved	
0004AC _H	CSVTR [R/W] --- 00010	CSVCR [R/W] - 011100	CSCFG [R/W] 0X000000	CMCFG [R/W] 00000000	Clock- Supervisor /Selector/ Monitor
0004B0 _H	CUCR [R/W] ----- 0 --- 00		CUTD [R/W] 10000000 00000000		Calibration of Sub Clock
0004B4 _H	CUTR1 [R] ----- 00000000		CUTR2 [R] 00000000 00000000		
0004B8 _H	CMPR [R/W] -- 000010 11111101		Reserved	CMCR [R/W] - 001 -- 00	Clock Modulator
0004BC _H	CMT1 [R/W] 00000000 1 --- 0000		CMT2 [R/W] -- 000000 -- 000000		
0004C0 _H	CANPRE [R/W] 0 --- 0000	CANCKD [R/W] ----- 0	Reserved		CAN Clock Control
0004C4 _H	LVSEL [R/W] 00000111	LVDET [R/W] 00000 - 00	HWWDE [R/W] ----- 00	HWWD [R/W,W] 00011000	Low Voltage Detection/ Hardware Watchdog
0004C8 _H	OSCRH [R/W] 000 -- 001	OSCR [R/W] ----- 000	WPCR [R/W] 000 -- 001	WPCRL [R/W] ----- 00	Main-/Sub-Oscillation Stabilisation Timer
0004CC _H	OSCCR [R/W] ----- 00	Reserved	REGSEL [R/W] -- 000110	REGCTR [R/W] --- 0 -- 00	Main- Oscillation Standby Control / Main/Sub Regulator Control
0004D0 _H to 00063C _H	Reserved				Reserved
000640 _H	ASR0 [R/W] 00000000 00000000		ACR0 [R/W] 1111**00 00000000*2		External Bus Unit
000644 _H	ASR1 [R/W] XXXXXXXX XXXXXXXXX		ACR1 [R/W] XXXXXXXX XXXXXXXXX		
000648 _H	ASR2 [R/W] XXXXXXXX XXXXXXXXX		ACR2 [R/W] XXXXXXXX XXXXXXXXX		
00064C _H	ASR3 [R/W] XXXXXXXX XXXXXXXXX		ACR3 [R/W] XXXXXXXX XXXXXXXXX		
000650 _H	ASR4 [R/W] XXXXXXXX XXXXXXXXX		ACR4 [R/W] XXXXXXXX XXXXXXXXX		
000654 _H	ASR5 [R/W] XXXXXXXX XXXXXXXXX		ACR5 [R/W] XXXXXXXX XXXXXXXXX		

Address	Register				Block	
	+0	+1	+2	+3		
000658 _H	ASR6 [R/W] XXXXXXXX XXXXXXXX		ACR6 [R/W] XXXXXXXX XXXXXXXX		External Bus Unit	
00065C _H	ASR7 [R/W] XXXXXXXX XXXXXXXX		ACR7 [R/W] XXXXXXXX XXXXXXXX			
000660 _H	AWR0 [R/W] 01111111 11111*11		AWR1 [R/W] XXXXXXXX XXXXXXXX			
000664 _H	AWR2 [R/W] XXXXXXXX XXXXXXXX		AWR3 [R/W] XXXXXXXX XXXXXXXX			
000668 _H	AWR4 [R/W] XXXXXXXX XXXXXXXX		AWR5 [R/W] XXXXXXXX XXXXXXXX			
00066C _H	AWR6 [R/W] XXXXXXXX XXXXXXXX		AWR7 [R/W] XXXXXXXX XXXXXXXX			
000670 _H	MCRA [R/W] XXXXXXXX	MCRB [R/W] XXXXXXXX	Reserved			
000674 _H	Reserved					
000678 _H	IOWR0 [R/W] XXXXXXXX	IOWR1 [R/W] XXXXXXXX	IOWR2 [R/W] XXXXXXXX	IOWR3 [R/W] XXXXXXXX		
00067C _H	Reserved					
000680 _H	CSER [R/W] 00000001	CHER [R/W] 11111111	Reserved	TCR [R/W] 0000**** *3		
000684 _H	RCRH [R/W] 00XXXXXX	RCRL [R/W] XXXX0XXX	Reserved			
000688 _H to 0007F8 _H	Reserved					
0007FC _H	Reserved	MODR [W] XXXXXXXX	Reserved			Mode Register
000800 _H to 000CFC _H	Reserved					Reserved
000D00 _H	PDRD00 [R] XXXXXXXX	PDRD01 [R] XXXXXXXX	Reserved		R-bus Port Data Direct Read Register	
000D04 _H	Reserved	PDRD05 [R] -- XXXXXX	PDRD06 [R] XXXXXXXX	PDRD07 [R] XXXXXXXX		
000D08 _H	PDRD08 [R] X--X---X	PDRD09 [R] -----XX	PDRD10 [R] -----X	Reserved		
000D0C _H	Reserved		PDRD14 [R] XXXXXXXX	PDRD15 [R] XXXXXXXX		
000D10 _H	PDRD16 [R] XXXXXXXX	PDRD17 [R] XXXXXXXX	PDRD18 [R] -XXX-XXX	PDRD19 [R] -XXX-XXX		
000D14 _H	PDRD20 [R] -XXX-XXX	PDRD21 [R] -----X	PDRD22 [R] XXXXXXXX	PDRD23 [R] XXXXXXXX		
000D18 _H	PDRD24 [R] XXXXXXXX	Reserved	PDRD26 [R] XXXXXXXX	PDRD27 [R] XXXXXXXX		
000D1C _H	PDRD28 [R] XXXXXXXX	PDRD29 [R] XXXXXXXX	Reserved			

Address	Register				Block
	+0	+1	+2	+3	
000D20 _H to 000D3C _H	Reserved				
000D40 _H	DDR00 [R/W] 00000000	DDR01 [R/W] 00000000	Reserved		R-bus Port Direction Register
000D44 _H	Reserved	DDR05 [R/W] -- 000000	DDR06 [R/W] 00000000	DDR07 [R/W] 00000000	
000D48 _H	DDR08 [R/W] 0--0--0	DDR09 [R/W] -----00	DDR10 [R/W] -----0	Reserved	
000D4C _H	Reserved		DDR14 [R/W] 00000000	DDR15 [R/W] 00000000	
000D50 _H	DDR16 [R/W] 00000000	DDR17 [R/W] 00000000	DDR18 [R/W] -000-000	DDR19 [R/W] -000-000	
000D54 _H	DDR20 [R/W] -000-000	DDR21 [R/W] -----00	DDR22 [R/W] 00000000	DDR23 [R/W] 00000000	
000D58 _H	DDR24 [R/W] 00000000	Reserved	DDR26 [R/W] 00000000	DDR27 [R/W] 00000000	
000D5C _H	DDR28 [R/W] 00000000	DDR29 [R/W] 00000000	Reserved		
000D60 _H to 000D7C _H	Reserved				
000D80 _H	PFR00 [R/W] 11111111	PFR01 [R/W] 11111111	Reserved		R-bus Port Function Register
000D84 _H	Reserved	PFR05 [R/W] -- 111111	PFR06 [R/W] 11111111	PFR07 [R/W] 11111111	
000D88 _H	PFR08 [R/W] 1--1--11	PFR09 [R/W] -----11	PFR10 [R/W] -----1	Reserved	
000D8C _H	Reserved		PFR14 [R/W] 00000000	PFR15 [R/W] 00000000	
000D90 _H	PFR16 [R/W] 00000000	PFR17 [R/W] 00000000	PFR18 [R/W] -000-000	PFR19 [R/W] -000-000	
000D94 _H	PFR20 [R/W] -000-000	PFR21 [R/W] -----00	PFR22 [R/W] 0000-0-0	PFR23 [R/W] -0000000	
000D98 _H	PFR24 [R/W] 00000000	Reserved	PFR26 [R/W] 00000000	PFR27 [R/W] 00000000	
000D9C _H	PFR28 [R/W] 00000000	PFR29 [R/W] 00000000	Reserved		
000DA0 _H to 000DC4 _H	Reserved				

Address	Register				Block
	+0	+1	+2	+3	
000DC8 _H	Reserved		EPFR10 [R/W] ----- 0	Reserved	R-bus Port Extra Function Register
000DCC _H	Reserved		EPFR14 [R/W] 00000000	EPFR15 [R/W] 00000000	
000DD0 _H	EPFR16 [R/W] 0 - 00 ----	Reserved	EPFR18 [R/W] - 000 - 000	EPFR19 [R/W] - 0 - - 0 - -	
000DD4 _H	EPFR20 [R/W] - 000 - 000	EPFR21 [R/W] -----	Reserved		
000DD8 _H	Reserved		EPFR26 [R/W] 00000000	EPFR27 [R/W] 00000000	
000DDC _H to 000DFC _H	Reserved				Reserved
000E00 _H	PODR00 [R/W] 00000000	PODR01 [R/W] 00000000	Reserved		R-bus Port Output Drive Select Register
000E04 _H	Reserved	PODR05 [R/W] -- 000000	PODR06 [R/W] 00000000	PODR07 [R/W] 00000000	
000E08 _H	PODR08 [R/W] 0 - - 0 - - - 0	PODR09 [R/W] ----- 00	PODR10 [R/W] ----- 0	Reserved	
000E0C _H	Reserved		PODR14 [R/W] 00000000	PODR15 [R/W] 00000000	
000E10 _H	PODR16 [R/W] 00000000	PODR17 [R/W] 00000000	PODR18 [R/W] - 000 - 000	PODR19 [R/W] - 000 - 000	
000E14 _H	PODR20 [R/W] - 000 - 000	PODR21 [R/W] ----- 00	PODR22 [R/W] 00000000	PODR23 [R/W] 00000000	
000E18 _H	PODR24 [R/W] 00000000	Reserved	PODR26 [R/W] 00000000	PODR27 [R/W] 00000000	
000E1C _H	PODR28 [R/W] 00000000	PODR29 [R/W] 00000000	Reserved		
000E20 _H to 000E3C _H	Reserved				Reserved

Address	Register				Block
	+0	+1	+2	+3	
000E40 _H	PILR00 [R/W] 00000000	PILR01 [R/W] 00000000	Reserved		R-bus Port Input Level Select Register
000E44 _H	Reserved	PILR05 [R/W] -- 000000	PILR06 [R/W] 00000000	PILR07 [R/W] 00000000	
000E48 _H	PILR08 [R/W] 0--0---0	PILR09 [R/W] -----00	PILR10 [R/W] -----0	Reserved	
000E4C _H	Reserved		PILR14 [R/W] 00000000	PILR15 [R/W] 00000000	
000E50 _H	PILR16 [R/W] 00000000	PILR17 [R/W] 00000000	PILR18 [R/W] -----000	PILR19 [R/W] -000-000	
000E54 _H	PILR20 [R/W] -000-000	PILR21 [R/W] -----00	PILR22 [R/W] 00000000	PILR23 [R/W] 00000000	
000E58 _H	PILR24 [R/W] 00000000	Reserved	PILR26 [R/W] 00000000	PILR27 [R/W] 00000000	
000E5C _H	PILR28 [R/W] 00000000	PILR29 [R/W] 00000000	Reserved		
000E60 _H to 000E7C _H	Reserved				Reserved
000E80 _H	EPILR00 [R/W] 00000000	EPILR01 [R/W] 00000000	Reserved		R-bus Port Extra Input Level Select Register
000E84 _H	Reserved	EPILR05 [R/W] -- 000000	EPILR06 [R/W] 00000000	EPILR07 [R/W] 00000000	
000E88 _H	EPILR08 [R/W] 0--0---0	EPILR09 [R/W] -----00	EPILR10 [R/W] -----0	Reserved	
000E8C _H	Reserved		EPILR14 [R/W] 00000000	EPILR15 [R/W] 00000000	
000E90 _H	EPILR16 [R/W] 00000000	EPILR17 [R/W] 00000000	EPILR18 [R/W] -----000	EPILR19 [R/W] -000-000	
000E94 _H	EPILR20 [R/W] -000-000	EPILR21 [R/W] -----00	EPILR22 [R/W] 00000000	EPILR23 [R/W] 00000000	
000E98 _H	EPILR24 [R/W] 00000000	Reserved	EPILR26 [R/W] 00000000	EPILR27 [R/W] 00000000	
000E9C _H	EPILR28 [R/W] 00000000	EPILR29 [R/W] 00000000	Reserved		
000EA0 _H to 000EBC _H	Reserved				Reserved

Address	Register				Block
	+0	+1	+2	+3	
000EC0 _H	PPER00 [R/W] 00000000	PPER01 [R/W] 00000000	Reserved		R-bus Port Pull-Up/Down Enable Register
000EC4 _H	Reserved	PPER05 [R/W] -- 000000	PPER06 [R/W] 00000000	PPER07 [R/W] 00000000	
000EC8 _H	PPER08 [R/W] 0--0---0	PPER09 [R/W] -----00	PPER10 [R/W] -----0	Reserved	
000ECC _H	Reserved		PPER14 [R/W] 00000000	PPER15 [R/W] 00000000	
000ED0 _H	PPER16 [R/W] 00000000	PPER17 [R/W] 00000000	PPER18 [R/W] -000-000	PPER19 [R/W] -000-000	
000ED4 _H	PPER20 [R/W] -000-000	PPER21 [R/W] -----00	PPER22 [R/W] 00000000	PPER23 [R/W] 00000000	
000ED8 _H	PPER24 [R/W] 00000000	Reserved	PPER26 [R/W] 00000000	PPER27 [R/W] 00000000	
000EDC _H	PPER28 [R/W] 00000000	PPER29 [R/W] 00000000	Reserved		
000EE0 _H to 000EFC _H	Reserved				Reserved
000F00 _H	PPCR00 [R/W] 11111111	PPCR01 [R/W] 11111111	Reserved		R-bus Port Pull-Up/Down Control Register
000F04 _H	Reserved	PPCR05 [R/W] -- 111111	PPCR06 [R/W] 11111111	PPCR07 [R/W] 11111111	
000F08 _H	PPCR08 [R/W] 1--1---1	PPCR09 [R/W] -----11	PPCR10 [R/W] -----1	Reserved	
000F0C _H	Reserved		PPCR14 [R/W] 00000000	PPCR15 [R/W] 11111111	
000F10 _H	PPCR16 [R/W] 00000000	PPCR17 [R/W] 00000000	PPCR18 [R/W] -111-111	PPCR19 [R/W] -111-111	
000F14 _H	PPCR20 [R/W] -111-111	PPCR21 [R/W] -----11	PPCR22 [R/W] 11111111	PPCR23 [R/W] 11111111	
000F18 _H	PPCR24 [R/W] 11111111	Reserved	PPCR26 [R/W] 11111111	PPCR27 [R/W] 11111111	
000F1C _H	PPCR28 [R/W] 11111111	PPCR29 [R/W] 11111111	Reserved		
000F20 _H to 000F3C _H	Reserved				Reserved

Address	Register				Block
	+0	+1	+2	+3	
001000 _H	DMASA0 [R/W] XXXXXXXX XXXXXXXX XXXXXXXX XXXXXXXX				DMAC
001004 _H	DMADA0 [R/W] XXXXXXXX XXXXXXXX XXXXXXXX XXXXXXXX				
001008 _H	DMASA1 [R/W] XXXXXXXX XXXXXXXX XXXXXXXX XXXXXXXX				
00100C _H	DMADA1 [R/W] XXXXXXXX XXXXXXXX XXXXXXXX XXXXXXXX				
001010 _H	DMASA2 [R/W] XXXXXXXX XXXXXXXX XXXXXXXX XXXXXXXX				
001014 _H	DMADA2 [R/W] XXXXXXXX XXXXXXXX XXXXXXXX XXXXXXXX				
001018 _H	DMASA3 [R/W] XXXXXXXX XXXXXXXX XXXXXXXX XXXXXXXX				
00101C _H	DMADA3 [R/W] XXXXXXXX XXXXXXXX XXXXXXXX XXXXXXXX				
001020 _H	DMASA4 [R/W] XXXXXXXX XXXXXXXX XXXXXXXX XXXXXXXX				
001024 _H	DMADA4 [R/W] XXXXXXXX XXXXXXXX XXXXXXXX XXXXXXXX				
001028 _H to 003FFC _H	Reserved				Reserved
002000 _H to 006FFC _H	Flash-cache size is 8 Kbytes: 004000 _H to 005FFC _H				Flash-cache / I-RAM area
007000 _H	FMCS [R/W] 01101000	FMCR [R/W] ---- 0000	FCHCR [R/W] ----- 00 10000011		Flash Memory/ I-Cache Control Register
007004 _H	FMWT [R/W] 11111111 11111111		Reserved	FMPS [R/W] ----- 000	
007008 _H	FMAC [R] 00000000 00000000 00000000 00000000				
00700C _H	FCHA0 [R/W] ----- -- 000000 00000000 00000000				I-Cache Non-cacheable area setting Register
007010 _H	FCHA1 [R/W] ----- -- 000000 00000000 00000000				
007014 _H to 007FFC _H	Reserved				Reserved
008000 _H to 00BFFC _H	Boot-ROM size is 4 Kbytes: 00B000 _H to 00BFFC _H (instruction access is 1 wait cycle, data access is 1 wait cycle)				Boot ROM area

Address	Register				Block
	+0	+1	+2	+3	
00C000 _H	CTRLR0 [R/W] 00000000 00000001		STATR0 [R/W] 00000000 00000000		CAN 0 Control Register
00C004 _H	ERRCNT0 [R] 00000000 00000000		BTR0 [R/W] 00100011 00000001		
00C008 _H	INTR0 [R] 00000000 00000000		TESTR0 [R/W] 00000000 X0000000		
00C00C _H	BRPE0 [R/W] 00000000 00000000		CBSYNC0		
00C010 _H	IF1CREQ0 [R/W] 00000000 00000001		IF1CMSK0 [R/W] 00000000 00000000		CAN 0 IF 1 Register
00C014 _H	IF1MSK20 [R/W] 11111111 11111111		IF1MSK10 [R/W] 11111111 11111111		
00C018 _H	IF1ARB20 [R/W] 00000000 00000000		IF1ARB10 [R/W] 00000000 00000000		
00C01C _H	IF1MCTR0 [R/W] 00000000 00000000		Reserved		
00C020 _H	IF1DTA10 [R/W] 00000000 00000000		IF1DTA20 [R/W] 00000000 00000000		
00C024 _H	IF1DTB10 [R/W] 00000000 00000000		IF1DTB20 [R/W] 00000000 00000000		
00C028 _H to 00C02C _H	Reserved				
00C030 _H	IF1DTA20 [R/W] 00000000 00000000		IF1DTA10 [R/W] 00000000 00000000		
00C034 _H	IF1DTB20 [R/W] 00000000 00000000		IF1DTB10 [R/W] 00000000 00000000		
00C038 _H to 00C03C _H	Reserved				
00C040 _H	IF2CREQ0 [R/W] 00000000 00000001		IF2CMSK0 [R/W] 00000000 00000000		CAN 0 IF 2 Register
00C044 _H	IF2MSK20 [R/W] 11111111 11111111		IF2MSK10 [R/W] 11111111 11111111		
00C048 _H	IF2ARB20 [R/W] 00000000 00000000		IF2ARB10 [R/W] 00000000 00000000		

Address	Register				Block
	+0	+1	+2	+3	
00C04 _C H	IF2MCTR0 [R/W] 00000000 00000000		Reserved		
00C05 _H	IF2DTA10 [R/W] 00000000 00000000		IF2DTA20 [R/W] 00000000 00000000		
00C05 ₄ H	IF2DTB10 [R/W] 00000000 00000000		IF2DTB20 [R/W] 00000000 00000000		
00C05 ₈ H to 00C05 _C H	Reserved				
00C06 ₀ H	IF2DTA20 [R/W] 00000000 00000000		IF2DTA10 [R/W] 00000000 00000000		
00C06 ₄ H	IF2DTB20 [R/W] 00000000 00000000		IF2DTB10 [R/W] 00000000 00000000		
00C06 ₈ H to 00C07 _C H	Reserved				
00C08 ₀ H	TREQR20 [R] 00000000 00000000		TREQR10 [R] 00000000 00000000		CAN 0 Status Flags
00C08 ₄ H to 00C08 _C H	Reserved		Reserved		
00C09 ₀ H	NEWDT20 [R] 00000000 00000000		NEWDT10 [R] 00000000 00000000		
00C09 ₄ H to 00C09 _C H	Reserved		Reserved		
00C0A ₀ H	INTPND20 [R] 00000000 00000000		INTPND10 [R] 00000000 00000000		
00C0A ₄ H to 00C0A _C H	Reserved		Reserved		
00C0B ₀ H	MSGVAL20 [R] 00000000 00000000		MSGVAL10 [R] 00000000 00000000		
00C0B ₄ H to 00C0B _C H	Reserved		Reserved		
00C10 ₀ H to 00E _{FF} C _H	Reserved				

Address	Register				Block
	+0	+1	+2	+3	
00F00 _H	BCTRL [R/W] ----- 11111100 00000000				EDSU / MPU
00F004 _H	BSTAT [R/W] ----- 000 00000000 10 -- 000000				
00F008 _H	BIAC [R] ----- 00000000 00000000				
00F00C _H	BOAC [R] ----- 00000000 00000000				
00F010 _H	BIRQ [R/W] ----- 00000000 00000000				
00F014 _H to 00F01C _H	Reserved				
00F020 _H	BCR0 [R/W] ----- 00000000 00000000 00000000				
00F024 _H	BCR1 [R/W] ----- 00000000 00000000 00000000				
00F028 _H	BCR2 [R/W] ----- 00000000 00000000 00000000				
00F02C _H	BCR3 [R/W] ----- 00000000 00000000 00000000				
00F030 _H to 00F07C _H	Reserved				Reserved

Address	Register				Block
	+0	+1	+2	+3	
00F080 _H	BAD0 [R/W] XXXXXXXX XXXXXXXX XXXXXXXX XXXXXXXX				EDSU / MPU
00F084 _H	BAD1 [R/W] XXXXXXXX XXXXXXXX XXXXXXXX XXXXXXXX				
00F088 _H	BAD2 [R/W] XXXXXXXX XXXXXXXX XXXXXXXX XXXXXXXX				
00F08C _H	BAD3 [R/W] XXXXXXXX XXXXXXXX XXXXXXXX XXXXXXXX				
00F090 _H	BAD4 [R/W] XXXXXXXX XXXXXXXX XXXXXXXX XXXXXXXX				
00F094 _H	BAD5 [R/W] XXXXXXXX XXXXXXXX XXXXXXXX XXXXXXXX				
00F098 _H	BAD6 [R/W] XXXXXXXX XXXXXXXX XXXXXXXX XXXXXXXX				
00F09C _H	BAD7 [R/W] XXXXXXXX XXXXXXXX XXXXXXXX XXXXXXXX				
00F0A0 _H	BAD8 [R/W] XXXXXXXX XXXXXXXX XXXXXXXX XXXXXXXX				
00F0A4 _H	BAD9 [R/W] XXXXXXXX XXXXXXXX XXXXXXXX XXXXXXXX				
00F0A8 _H	BAD10 [R/W] XXXXXXXX XXXXXXXX XXXXXXXX XXXXXXXX				
00F0AC _H	BAD11 [R/W] XXXXXXXX XXXXXXXX XXXXXXXX XXXXXXXX				
00F0B0 _H	BAD12 [R/W] XXXXXXXX XXXXXXXX XXXXXXXX XXXXXXXX				
00F0B4 _H	BAD13 [R/W] XXXXXXXX XXXXXXXX XXXXXXXX XXXXXXXX				
00F0B8 _H	BAD14 [R/W] XXXXXXXX XXXXXXXX XXXXXXXX XXXXXXXX				
00F0BC _H	BAD15 [R/W] XXXXXXXX XXXXXXXX XXXXXXXX XXXXXXXX				
00F0C0 _H to 01FFFC _H	Reserved				
020000 _H to 02FFFC _H	CY91F466HA D-RAM size is 24 Kbytes: 02A000H - 02FFFC CY91F464HB D-RAM size is 16 Kbytes: 02C000H - 02FFFC (data access is 0 wait cycles)				D-RAM area
030000 _H to 03FFFC _H	ID-RAM size is 16 Kbytes: 030000 _H - 03FFFC _H (instruction access is 0 wait cycles, data access is 1 wait cycle)				ID-RAM area

*1: depends on the number of available CAN channels

*2: ACR0 [11 : 10] depends on Mode vector fetch information on bus width

*3: TCR [3 : 0] INIT value = 0000, keeps value after RST

12.2 Flash Memory and External Bus Area

12.2.1 CY91F464HB, CY91F466HA

CY91F464HB

32 bit read 16 bit read/write	dat[31:0]				dat[31:0]				Block		
	dat[31:16]	dat[15:0]	dat[31:16]	dat[15:0]	Register						
Address	Register								Block		
	+0	+1	+2	+3	+4	+5	+6	+7			
040000h to 05FFF8h	Reserved				Reserved				ROMS0		
060000h to 07FFF8h	Reserved				Reserved				ROMS1		
080000h to 09FFF8h	Reserved				Reserved				ROMS2		
0A0000h to 0BFFF8h	SA14 (64 KB)				SA15 (64 KB)				ROMS3		
0C0000h to 0DFFF8h	SA16 (64 KB)				SA17 (64 KB)				ROMS4		
0E0000h to 0FFFF0h	SA18 (64 KB)				SA19 (64 KB)				ROMS5		
0FFFF8h	FMV [R] 06 00 00 00h				FMV [R] 00 00 BF F8h						
100000h to 11FFF8h	External Bus Area								ROMS6		
120000h to 13FFF8h											
140000h to 143FF8h	External Bus Area								ROMS7		
144000h to 147FF8h											
148000h to 14BFF8h	SA4 (8 KB)				SA5 (8 KB)				ROMS7		
14C000h to 14FFF8h	SA6 (8 KB)				SA7 (8 KB)						
150000h to 17FFF8h	Reserved										
180000h to 1BFFF8h	External Bus Area								ROMS8		
1C0000h to 1FFFF8h									ROMS9		
200000h to 27FFF8h									ROMS10		
280000h to 2FFFF8h									ROMS11		
300000h to 37FFF8h									ROMS12		
380000h to 3FFFF8h									ROMS13		
400000h to 47FFF8h									ROMS14		
480000h to 4FFFF8h									ROMS15		

CY91F466HA

64 bit read 32 bit read/write 16 bit read/write	dat[63:0]								Block
	dat[31:0]				dat[31:0]				
Address	Register								Block
	+0	+1	+2	+3	+4	+5	+6	+7	
040000h to 05FFF8h	SA8 (64 KB)				SA9 (64 KB)				ROMS0
060000h to 07FFF8h	SA10 (64 KB)				SA11 (64 KB)				ROMS1
080000h to 09FFF8h	SA12 (64 KB)				SA13 (64 KB)				ROMS2
0A0000h to 0BFFF8h	SA14 (64 KB)				SA15 (64 KB)				ROMS3
0C0000h to 0DFFF8h	SA16 (64 KB)				SA17 (64 KB)				ROMS4
0E0000h to 0FFFF0h	SA18 (64 KB)				SA19 (64 KB)				ROMS5
0FFFF8h	FMV [R] 06 00 00 00h				FMV [R] 00 00 BF F8h				
100000h to 11FFF8h	External Bus Area								ROMS6
120000h to 13FFF8h									
140000h to 143FF8h	SA0 (8 KB)				SA1 (8 KB)				ROMS7
144000h to 147FF8h	SA2 (8 KB)				SA3 (8 KB)				
148000h to 14BFF8h	SA4 (8 KB)				SA5 (8 KB)				
14C000h to 14FFF8h	SA6 (8 KB)				SA7 (8 KB)				
150000h to 17FFF8h	Reserved								
180000h to 1BFFF8h	External Bus Area								ROMS8
1C0000h to 1FFFF8h									ROMS9
200000h to 27FFF8h									ROMS10
280000h to 2FFFF8h									ROMS11
300000h to 37FFF8h									ROMS12
380000h to 3FFFF8h									ROMS13
400000h to 47FFF8h									ROMS14
480000h to 4FFFF8h									ROMS15

Note: Write operations to address 0FFFF8h and 0FFFFCh are not possible. When reading these addresses, the values shown above will be read.

13. Interrupt Vector Table

Interrupt	Interrupt number		Interrupt level *1		Interrupt vector *2		DMA Resource number
	Decimal	Hexa-decimal	Setting Register	Register address	Offset	Default vector address	
Reset	0	00	—	—	3FC _H	000FFFC _H	—
Mode vector	1	01	—	—	3F8 _H	000FFF8 _H	—
System reserved	2	02	—	—	3F4 _H	000FFF4 _H	—
System reserved	3	03	—	—	3F0 _H	000FFF0 _H	—
System reserved	4	04	—	—	3EC _H	000FFEC _H	—
CPU supervisor mode (INT #5 instruction) *5	5	05	—	—	3E8 _H	000FFE8 _H	—
Memory Protection exception *5	6	06	—	—	3E4 _H	000FFE4 _H	—
System reserved	7	07	—	—	3E0 _H	000FFE0 _H	—
System reserved	8	08	—	—	3DC _H	000FFDC _H	—
System reserved	9	09	—	—	3D8 _H	000FFD8 _H	—
System reserved	10	0A	—	—	3D4 _H	000FFD4 _H	—
System reserved	11	0B	—	—	3D0 _H	000FFD0 _H	—
System reserved	12	0C	—	—	3CC _H	000FFCC _H	—
System reserved	13	0D	—	—	3C8 _H	000FFC8 _H	—
Undefined instruction exception	14	0E	—	—	3C4 _H	000FFC4 _H	—
NMI request	15	0F	F _H fixed		3C0 _H	000FFC0 _H	—
External Interrupt 0	16	10	ICR00	440 _H	3BC _H	000FFBC _H	0, 16
External Interrupt 1	17	11			3B8 _H	000FFB8 _H	1, 17
External Interrupt 2	18	12	ICR01	441 _H	3B4 _H	000FFB4 _H	2, 18
External Interrupt 3	19	13			3B0 _H	000FFB0 _H	3, 19
External Interrupt 4	20	14	ICR02	442 _H	3AC _H	000FFAC _H	20
External Interrupt 5	21	15			3A8 _H	000FFA8 _H	21
External Interrupt 6	22	16	ICR03	443 _H	3A4 _H	000FFA4 _H	22
External Interrupt 7	23	17			3A0 _H	000FFA0 _H	23
External Interrupt 8	24	18	ICR04	444 _H	39C _H	000FFF9C _H	—
External Interrupt 9	25	19			398 _H	000FFF98 _H	—
External Interrupt 10	26	1A	ICR05	445 _H	394 _H	000FFF94 _H	—
External Interrupt 11	27	1B			390 _H	000FFF90 _H	—
External Interrupt 12	28	1C	ICR06	446 _H	38C _H	000FFF8C _H	—
External Interrupt 13	29	1D			388 _H	000FFF88 _H	—
External Interrupt 14	30	1E	ICR07	447 _H	384 _H	000FFF84 _H	—
External Interrupt 15	31	1F			380 _H	000FFF80 _H	—
Reload Timer 0	32	20	ICR08	448 _H	37C _H	000FFF7C _H	4, 32
Reload Timer 1	33	21			378 _H	000FFF78 _H	5, 33

Interrupt	Interrupt number		Interrupt level *1		Interrupt vector *2		DMA Resource number
	Decimal	Hexa-decimal	Setting Register	Register address	Offset	Default vector address	
Reload Timer 2	34	22	ICR09	449 _H	374 _H	000FFF74 _H	34
Reload Timer 3	35	23			370 _H	000FFF70 _H	35
Reload Timer 4	36	24	ICR10	44A _H	36C _H	000FFF6C _H	36
Reload Timer 5	37	25			368 _H	000FFF68 _H	37
Reload Timer 6	38	26	ICR11	44B _H	364 _H	000FFF64 _H	38
Reload Timer 7	39	27			360 _H	000FFF60 _H	39
Free Run Timer 0	40	28	ICR12	44C _H	35C _H	000FFF5C _H	40
Free Run Timer 1	41	29			358 _H	000FFF58 _H	41
Free Run Timer 2	42	2A	ICR13	44D _H	354 _H	000FFF54 _H	42
Free Run Timer 3	43	2B			350 _H	000FFF50 _H	43
Free Run Timer 4	44	2C	ICR14	44E _H	34C _H	000FFF4C _H	44
Free Run Timer 5	45	2D			348 _H	000FFF48 _H	45
Free Run Timer 6	46	2E	ICR15	44F _H	344 _H	000FFF44 _H	46
Free Run Timer 7	47	2F			340 _H	000FFF40 _H	47
CAN 0	48	30	ICR16	450 _H	33C _H	000FFF3C _H	—
Reserved	49	31			338 _H	000FFF38 _H	—
Reserved	50	32	ICR17	451 _H	334 _H	000FFF34 _H	—
Reserved	51	33			330 _H	000FFF30 _H	—
Reserved	52	34	ICR18	452 _H	32C _H	000FFF2C _H	—
Reserved	53	35			328 _H	000FFF28 _H	—
LIN-USART 0 RX	54	36	ICR19	453 _H	324 _H	000FFF24 _H	6, 48
LIN-USART 0 TX	55	37			320 _H	000FFF20 _H	7, 49
Reserved	56	38	ICR20	454 _H	31C _H	000FFF1C _H	8, 50
Reserved	57	39			318 _H	000FFF18 _H	9, 51
LIN-USART 2 RX	58	3A	ICR21	455 _H	314 _H	000FFF14 _H	52
LIN-USART 2 TX	59	3B			310 _H	000FFF10 _H	53
LIN-USART 3 RX	60	3C	ICR22	456 _H	30C _H	000FFF0C _H	54
LIN-USART 3 TX	61	3D			308 _H	000FFF08 _H	55
System Reserved	62	3E	ICR23 *3	457 _H	304 _H	000FFF04 _H	—
Delayed Interrupt	63	3F			300 _H	000FFF00 _H	—
System Reserved *4	64	40	ICR24	458 _H	2FC _H	000FFEFC _H	—
System Reserved *4	65	41			2F8 _H	000FFE8 _H	—
LIN-USART (FIFO) 4 RX	66	42	ICR25	459 _H	2F4 _H	000FEF4 _H	10, 56
LIN-USART (FIFO) 4 TX	67	43			2F0 _H	000FEF0 _H	11, 57
LIN-USART (FIFO) 5 RX	68	44	ICR26	45A _H	2EC _H	000FEEC _H	12, 58
LIN-USART (FIFO) 5 TX	69	45			2E8 _H	000FEE8 _H	13, 59

Interrupt	Interrupt number		Interrupt level *1		Interrupt vector *2		DMA Resource number
	Decimal	Hexa-decimal	Setting Register	Register address	Offset	Default vector address	
LIN-USART (FIFO) 6 RX	70	46	ICR27	45B _H	2E4 _H	000FFEE4 _H	60
LIN-USART (FIFO) 6 TX	71	47			2E0 _H	000FFEE0 _H	61
LIN-USART (FIFO) 7 RX	72	48	ICR28	45C _H	2DC _H	000FFEDC _H	62
LIN-USART (FIFO) 7 TX	73	49			2D8 _H	000FFED8 _H	63
I ² C 0	74	4A	ICR29	45D _H	2D4 _H	000FFED4 _H	—
I ² C 1	75	4B			2D0 _H	000FFED0 _H	—
Reserved	76	4C	ICR30	45E _H	2CC _H	000FFEC _C	64
Reserved	77	4D			2C8 _H	000FFEC8 _H	65
Reserved	78	4E	ICR31	45F _H	2C4 _H	000FFEC4 _H	66
Reserved	79	4F			2C0 _H	000FFEC0 _H	67
Reserved	80	50	ICR32	460 _H	2BC _H	000FFEB _C	68
Reserved	81	51			2B8 _H	000FFEB8 _H	69
Reserved	82	52	ICR33	461 _H	2B4 _H	000FFEB4 _H	70
Reserved	83	53			2B0 _H	000FFEB0 _H	71
Reserved	84	54	ICR34	462 _H	2AC _H	000FFEAC _H	72
Reserved	85	55			2A8 _H	000FFEA8 _H	73
Reserved	86	56	ICR35	463 _H	2A4 _H	000FFEA4 _H	74
Reserved	87	57			2A0 _H	000FFEA0 _H	75
Reserved	88	58	ICR36	464 _H	29C _H	000FFE9 _C	76
Reserved	89	59			298 _H	000FFE98 _H	77
Reserved	90	5A	ICR37	465 _H	294 _H	000FFE94 _H	78
Reserved	91	5B			290 _H	000FFE90 _H	79
Input Capture 0	92	5C	ICR38	466 _H	28C _H	000FFE8 _C	80
Input Capture 1	93	5D			288 _H	000FFE88 _H	81
Input Capture 2	94	5E	ICR39	467 _H	284 _H	000FFE84 _H	82
Input Capture 3	95	5F			280 _H	000FFE80 _H	83
Input Capture 4	96	60	ICR40	468 _H	27C _H	000FFE7 _C	84
Input Capture 5	97	61			278 _H	000FFE78 _H	85
Input Capture 6	98	62	ICR41	469 _H	274 _H	000FFE74 _H	86
Input Capture 7	99	63			270 _H	000FFE70 _H	87
Output Compare 0	100	64	ICR42	46A _H	26C _H	000FFE6 _C	88
Output Compare 1	101	65			268 _H	000FFE68 _H	89
Output Compare 2	102	66	ICR43	46B _H	264 _H	000FFE64 _H	90
Output Compare 3	103	67			260 _H	000FFE60 _H	91
Output Compare 4	104	68	ICR44	46C _H	25C _H	000FFE5 _C	92
Output Compare 5	105	69			258 _H	000FFE58 _H	93

Interrupt	Interrupt number		Interrupt level *1		Interrupt vector *2		DMA Resource number
	Decimal	Hexa-decimal	Setting Register	Register address	Offset	Default vector address	
Output Compare 6	106	6A	ICR45	46D _H	254 _H	000FFE54 _H	94
Output Compare 7	107	6B			250 _H	000FFE50 _H	95
Sound Generator	108	6C	ICR46	46E _H	24C _H	000FFE4C _H	—
Reserved	109	6D			248 _H	000FFE48 _H	—
System Reserved	110	6E	ICR47 *3	46F _H	244 _H	000FFE44 _H	—
System Reserved	111	6F			240 _H	000FFE40 _H	—
PPG 0	112	70	ICR48	470 _H	23C _H	000FFE3C _H	15, 96
PPG 1	113	71			238 _H	000FFE38 _H	97
PPG 2	114	72	ICR49	471 _H	234 _H	000FFE34 _H	98
PPG 3	115	73			230 _H	000FFE30 _H	99
PPG 4	116	74	ICR50	472 _H	22C _H	000FFE2C _H	100
PPG 5	117	75			228 _H	000FFE28 _H	101
PPG 6	118	76	ICR51	473 _H	224 _H	000FFE24 _H	102
PPG 7	119	77			220 _H	000FFE20 _H	103
PPG 8	120	78	ICR52	474 _H	21C _H	000FFE1C _H	104
PPG 9	121	79			218 _H	000FFE18 _H	105
PPG 10	122	7A	ICR53	475 _H	214 _H	000FFE14 _H	106
PPG 11	123	7B			210 _H	000FFE10 _H	107
PPG 12	124	7C	ICR54	476 _H	20C _H	000FFE0C _H	108
PPG 13	125	7D			208 _H	000FFE08 _H	109
PPG 14	126	7E	ICR55	477 _H	204 _H	000FFE04 _H	110
PPG 15	127	7F			200 _H	000FFE00 _H	111
Up/Down Counter 0	128	80	ICR56	478 _H	1FC _H	000FFDFC _H	—
Up/Down Counter 1	129	81			1F8 _H	000FFDF8 _H	—
Reserved	130	82	ICR57	479 _H	1F4 _H	000FFDF4 _H	—
Reserved	131	83			1F0 _H	000FFDF0 _H	—
Real Time Clock	132	84	ICR58	47A _H	1EC _H	000FFDEC _H	—
Calibration Unit	133	85			1E8 _H	000FFDE8 _H	—
A/D Converter 0	134	86	ICR59	47B _H	1E4 _H	000FFDE4 _H	14, 112
System reserved	135	87			1E0 _H	000FFDE0 _H	—
Alarm Comparator 0	136	88	ICR60	47C _H	1DC _H	000FFDDC _H	—
Reserved	137	89			1D8 _H	000FFDD8 _H	—
Low Voltage Detection	138	8A	ICR61	47D _H	1D4 _H	000FFDD4 _H	—
Reserved	139	8B			1D0 _H	000FFDD0 _H	—
Time base Overflow	140	8C	ICR62	47E _H	1CC _H	000FFDCC _H	—
PLL Clock Gear	141	8D			1C8 _H	000FFDC8 _H	—

Interrupt	Interrupt number		Interrupt level *1		Interrupt vector *2		DMA Resource number
	Decimal	Hexa-decimal	Setting Register	Register address	Offset	Default vector address	
DMA Controller	142	8E	ICR63	47F _H	1C4 _H	000FFDC4 _H	—
Main/Sub OSC stability wait	143	8F			1C0 _H	000FFDC0 _H	—
Security vector	144	90	—	—	1BC _H	000FFDBC _H	—
Used by the INT instruction.	145 to 255	91 to FF	—	—	1B8 _H to 000 _H	000FFDB8 _H to 000FFC00 _H	—

*1 : The Interrupt Control Registers (ICRs) are located in the interrupt controller and set the interrupt level for each interrupt request. An ICR is provided for each interrupt request.

*2 : The vector address for each EIT (exception, interrupt or trap) is calculated by adding the listed offset to the table base register value (TBR) . The TBR specifies the top of the EIT vector table. The addresses listed in the table are for the default TBR value (000FFC00_H) . The TBR is initialized to this value by a reset. The TBR is set to 000FFC00_H after the internal boot ROM is executed.

*3 : ICR23 and ICR47 can be exchanged by setting the REALOS compatibility bit (addr 0C03_H : IOS[0])

*4 : Used by REALOS

*5 : Memory Protection Unit (MPU) support

14. Recommended Settings

14.1 PLL and Clockgear Settings

Please note that for CY91F464HB the core base clock frequencies are valid in the 1.8 V operation mode of the Main regulator and Flash.

Please refer to “Absolute maximum ratings” on page 77 to find the maximum allowed frequency of Core Base Clock (f_{CLKB}) at high temperature.

Recommended PLL divider and clockgear settings

PLL Input (CLK) [MHz]	Frequency Parameter		Clockgear Parameter		PLL Output (X) [MHz]	Core Base Clock [MHz]	Remarks
	DIVM	DIVN	DIVG	MULG			
4	2	25	16	24	200	100	*1
4	2	24	16	24	192	96	
4	2	23	16	24	184	92	
4	2	22	16	24	176	88	
4	2	21	16	20	168	84	
4	2	20	16	20	160	80	
4	2	19	16	20	152	76	
4	2	18	16	20	144	72	
4	2	17	16	16	136	68	
4	2	16	16	16	128	64	
4	2	15	16	16	120	60	
4	2	14	16	16	112	56	
4	2	13	16	12	104	52	
4	2	12	16	12	96	48	
4	2	11	16	12	88	44	
4	4	10	16	24	160	40	
4	4	9	16	24	144	36	
4	4	8	16	24	128	32	
4	4	7	16	24	112	28	
4	6	6	16	24	144	24	
4	8	5	16	28	160	20	
4	10	4	16	32	160	16	
4	12	3	16	32	144	12	

*1. This setting is not possible at CY91F466HA.

14.2 Clock Modulator Settings

The following table shows all possible settings for the Clock Modulator in a base clock frequency range from 32 MHz up to 88 MHz. The Flash access time settings need to be adjusted according to Fmax while the PLL and clockgear settings should be set according to base clock frequency.

Please refer to “Absolute maximum ratings” on page 77 to find the maximum allowed frequency of Fmax (f_{CLKB}) at high temperature.

Clock Modulator settings, frequency range and supported supply voltage

Modulation Degree (k)	Random No (N)	CMPR [hex]	Baseclk [MHz]	Fmin [MHz]	Fmax [MHz]	Remarks
1	3	026F	88	79.5	98.5	*1
1	3	026F	84	76.1	93.8	
1	3	026F	80	72.6	89.1	
1	5	02AE	80	68.7	95.8	
2	3	046E	80	68.7	95.8	
1	3	026F	76	69.1	84.5	
1	5	02AE	76	65.3	90.8	
1	7	02ED	76	62	98.1	*1
2	3	046E	76	65.3	90.8	
3	3	066D	76	62	98.1	*1
1	3	026F	72	65.5	79.9	
1	5	02AE	72	62	85.8	
1	7	02ED	72	58.8	92.7	
2	3	046E	72	62	85.8	
3	3	066D	72	58.8	92.7	
1	3	026F	68	62	75.3	
1	5	02AE	68	58.7	80.9	
1	7	02ED	68	55.7	87.3	
1	9	032C	68	53	95	
2	3	046E	68	58.7	80.9	
2	5	04AC	68	53	95	
3	3	066D	68	55.7	87.3	
4	3	086C	68	53	95	
1	3	026F	64	58.5	70.7	
1	5	02AE	64	55.3	75.9	
1	7	02ED	64	52.5	82	
1	9	032C	64	49.9	89.1	
1	11	036B	64	47.6	97.6	*1
2	3	046E	64	55.3	75.9	
2	5	04AC	64	49.9	89.1	
3	3	066D	64	52.5	82	
4	3	086C	64	49.9	89.1	
5	3	0A6B	64	47.6	97.6	

Modulation Degree (k)	Random No (N)	CMPR [hex]	Baseclk [MHz]	Fmin [MHz]	Fmax [MHz]	Remarks
1	3	026F	60	54.9	66.1	
1	5	02AE	60	51.9	71	
1	7	02ED	60	49.3	76.7	
1	9	032C	60	46.9	83.3	
1	11	036B	60	44.7	91.3	
2	3	046E	60	51.9	71	
2	5	04AC	60	46.9	83.3	
3	3	066D	60	49.3	76.7	
4	3	086C	60	46.9	83.3	
5	3	0A6B	60	44.7	91.3	
1	3	026F	56	51.4	61.6	
1	5	02AE	56	48.6	66.1	
1	7	02ED	56	46.1	71.4	
1	9	032C	56	43.8	77.6	
1	11	036B	56	41.8	84.9	
1	13	03AA	56	39.9	93.8	
2	3	046E	56	48.6	66.1	
2	5	04AC	56	43.8	77.6	
2	7	04EA	56	39.9	93.8	
3	3	066D	56	46.1	71.4	
3	5	06AA	56	39.9	93.8	
4	3	086C	56	43.8	77.6	
5	3	0A6B	56	41.8	84.9	
6	3	0C6A	56	39.9	93.8	
1	3	026F	52	47.8	57	
1	5	02AE	52	45.2	61.2	
1	7	02ED	52	42.9	66.1	
1	9	032C	52	40.8	71.8	
1	11	036B	52	38.8	78.6	
1	13	03AA	52	37.1	86.8	
1	15	03E9	52	35.5	96.9	*1
2	3	046E	52	45.2	61.2	
2	5	04AC	52	40.8	71.8	
2	7	04EA	52	37.1	86.8	
3	3	066D	52	42.9	66.1	
3	5	06AA	52	37.1	86.8	
4	3	086C	52	40.8	71.8	
5	3	0A6B	52	38.8	78.6	

Modulation Degree (k)	Random No (N)	CMPR [hex]	Baseclk [MHz]	Fmin [MHz]	Fmax [MHz]	Remarks
6	3	0C6A	52	37.1	86.8	
7	3	0E69	52	35.5	96.9	*1
1	3	026F	48	44.2	52.5	
1	5	02AE	48	41.8	56.4	
1	7	02ED	48	39.6	60.9	
1	9	032C	48	37.7	66.1	
1	11	036B	48	35.9	72.3	
1	13	03AA	48	34.3	79.9	
1	15	03E9	48	32.8	89.1	
2	3	046E	48	41.8	56.4	
2	5	04AC	48	37.7	66.1	
2	7	04EA	48	34.3	79.9	
3	3	066D	48	39.6	60.9	
3	5	06AA	48	34.3	79.9	
4	3	086C	48	37.7	66.1	
5	3	0A6B	48	35.9	72.3	
6	3	0C6A	48	34.3	79.9	
7	3	0E69	48	32.8	89.1	
1	3	026F	44	40.6	48.1	
1	5	02AE	44	38.4	51.6	
1	7	02ED	44	36.4	55.7	
1	9	032C	44	34.6	60.4	
1	11	036B	44	33	66.1	
1	13	03AA	44	31.5	73	
1	15	03E9	44	30.1	81.4	
2	3	046E	44	38.4	51.6	
2	5	04AC	44	34.6	60.4	
2	7	04EA	44	31.5	73	
2	9	0528	44	28.9	92.1	
3	3	066D	44	36.4	55.7	
3	5	06AA	44	31.5	73	
4	3	086C	44	34.6	60.4	
4	5	08A8	44	28.9	92.1	
5	3	0A6B	44	33	66.1	
6	3	0C6A	44	31.5	73	
7	3	0E69	44	30.1	81.4	
8	3	1068	44	28.9	92.1	
1	3	026F	40	37	43.6	

Modulation Degree (k)	Random No (N)	CMPR [hex]	Baseclk [MHz]	Fmin [MHz]	Fmax [MHz]	Remarks
1	5	02AE	40	34.9	46.8	
1	7	02ED	40	33.1	50.5	
1	9	032C	40	31.5	54.8	
1	11	036B	40	30	59.9	
1	13	03AA	40	28.7	66.1	
1	15	03E9	40	27.4	73.7	
2	3	046E	40	34.9	46.8	
2	5	04AC	40	31.5	54.8	
2	7	04EA	40	28.7	66.1	
2	9	0528	40	26.3	83.3	
3	3	066D	40	33.1	50.5	
3	5	06AA	40	28.7	66.1	
3	7	06E7	40	25.3	95.8	
4	3	086C	40	31.5	54.8	
4	5	08A8	40	26.3	83.3	
5	3	0A6B	40	30	59.9	
6	3	0C6A	40	28.7	66.1	
7	3	0E69	40	27.4	73.7	
8	3	1068	40	26.3	83.3	
9	3	1267	40	25.3	95.8	
1	3	026F	36	33.3	39.2	
1	5	02AE	36	31.5	42	
1	7	02ED	36	29.9	45.3	
1	9	032C	36	28.4	49.2	
1	11	036B	36	27.1	53.8	
1	13	03AA	36	25.8	59.3	
1	15	03E9	36	24.7	66.1	
2	3	046E	36	31.5	42	
2	5	04AC	36	28.4	49.2	
2	7	04EA	36	25.8	59.3	
2	9	0528	36	23.7	74.7	
3	3	066D	36	29.9	45.3	
3	5	06AA	36	25.8	59.3	
3	7	06E7	36	22.8	85.8	
4	3	086C	36	28.4	49.2	
4	5	08A8	36	23.7	74.7	
5	3	0A6B	36	27.1	53.8	
6	3	0C6A	36	25.8	59.3	

Modulation Degree (k)	Random No (N)	CMPR [hex]	Baseclk [MHz]	Fmin [MHz]	Fmax [MHz]	Remarks
7	3	0E69	36	24.7	66.1	
8	3	1068	36	23.7	74.7	
9	3	1267	36	22.8	85.8	
1	3	026F	32	29.7	34.7	
1	5	02AE	32	28	37.3	
1	7	02ED	32	26.6	40.2	
1	9	032C	32	25.3	43.6	
1	11	036B	32	24.1	47.7	
1	13	03AA	32	23	52.5	
1	15	03E9	32	22	58.6	
2	3	046E	32	28	37.3	
2	5	04AC	32	25.3	43.6	
2	7	04EA	32	23	52.5	
2	9	0528	32	21.1	66.1	
2	11	0566	32	19.5	89.1	
3	3	066D	32	26.6	40.2	
3	5	06AA	32	23	52.5	
3	7	06E7	32	20.3	75.9	
4	3	086C	32	25.3	43.6	
4	5	08A8	32	21.1	66.1	
5	3	0A6B	32	24.1	47.7	
5	5	0AA6	32	19.5	89.1	
6	3	0C6A	32	23	52.5	
7	3	0E69	32	22	58.6	
8	3	1068	32	21.1	66.1	
9	3	1267	32	20.3	75.9	
10	3	1466	32	19.5	89.1	

*1. These settings are not possible at CY91F466HA.

15. Electrical Characteristics

15.1 Absolute Maximum Ratings

Parameter	Symbol	Rating		Unit	Remarks
		Min	Max		
Power supply slew rate	—	—	50	V/ms	
Power supply voltage 1 *1	V _{DD5R}	- 0.3	+ 6.0	V	
Power supply voltage 2 *1	V _{DD5}	- 0.3	+ 6.0	V	
Relationship of the supply voltages	AV _{CC5}	V _{DD5} -0.3 V _{DD35} -0.3	V _{DD5} +0.3 V _{DD35} +0.3	V	At least one pin of the Ports 26 to 29 (ANn) is used as digital input or output.
		V _{SS5} -0.3 V _{DD35} -0.3	V _{DD5} +0.3 V _{DD35} +0.3	V	All pins of the Ports 26 to 29 (ANn) follow the condition of V _{IA}
Analog power supply voltage *1	AV _{CC5}	- 0.3	+ 6.0	V	*2
Analog reference power supply voltage *1	AVRH	- 0.3	+ 6.0	V	*2
Input voltage 1 *1	V _{I1}	V _{SS5} - 0.3	V _{DD5} + 0.3	V	
Analog pin input voltage *1	V _{IA}	AV _{SS5} - 0.3	AV _{CC5} + 0.3	V	
Output voltage 1 *1	V _{O1}	V _{SS5} - 0.3	V _{DD5} + 0.3	V	
Maximum clamp current	I _{CLAMP}	- 4.0	+ 4.0	mA	*3
Total maximum clamp current	∑ I _{CLAMP}	—	20	mA	*3
"L" level maximum output current *4	I _{OL}	—	10	mA	
"L" level average output current *5	I _{OLAV}	—	8	mA	
"L" level total maximum output current	∑ I _{OL}	—	100	mA	
"L" level total average output current *6	∑ I _{OLAV}	—	50	mA	
"H" level maximum output current *4	I _{OH}	—	- 10	mA	
"H" level average output current *5	I _{OHAV}	—	- 4	mA	
"H" level total maximum output current	∑ I _{OH}	—	- 100	mA	
"H" level total average output current *6	∑ I _{OHAV}	—	- 25	mA	
Permitted operating frequency CY91F464HB	f _{max} , CLKB	—	100	MHz	T _A ≤ 105 °C
	f _{max} , CLKP	—	50		
	f _{max} , CLKT	—	50		
	f _{max} , CLKCAN	—	50		
	f _{max} , CLKB	—	96	MHz	T _A ≤ 125 °C
	f _{max} , CLKP	—	48		
	f _{max} , CLKT	—	48		
	f _{max} , CLKCAN	—	48		

Parameter	Symbol	Rating		Unit	Remarks
		Min	Max		
Permitted operating frequency CY91F466HA	$f_{\max, \text{CLKB}}$	—	96	MHz	$T_A \leq 105^\circ\text{C}$
	$f_{\max, \text{CLKP}}$	—	48		
	$f_{\max, \text{CLKT}}$	—	48		
	$f_{\max, \text{CLKCAN}}$	—	48		
	$f_{\max, \text{CLKB}}$	—	92	MHz	$T_A \leq 125^\circ\text{C}$
	$f_{\max, \text{CLKP}}$	—	46		
	$f_{\max, \text{CLKT}}$	—	46		
	$f_{\max, \text{CLKCAN}}$	—	46		
Permitted power dissipation ^{*7}	P_D	—	1200 ^{*8}	mW	$T_A \leq 85^\circ\text{C}$
		—	600 ^{*8}		$T_A \leq 105^\circ\text{C}$
		—	1300 ^{*8}		$T_A \leq 105^\circ\text{C}$, no Flash program/erase ^{*9}
		—	1000 ^{*8}		$T_A \leq 115^\circ\text{C}$, no Flash program/erase ^{*9}
		—	750 ^{*8}		$T_A \leq 125^\circ\text{C}$, no Flash program/erase ^{*9}
Operating temperature	T_A	- 40	+ 125	$^\circ\text{C}$	
Storage temperature	T_{stg}	- 55	+ 150	$^\circ\text{C}$	

*1 : The parameter is based on $V_{\text{SS}5} = \text{AV}_{\text{SS}5} = 0.0\text{ V}$.

*2 : $\text{AV}_{\text{CC}5}$ and $\text{AV}_{\text{RH}5}$ must not exceed $V_{\text{DD}5} + 0.3\text{ V}$.

- *3 :
- Use within recommended operating conditions.
 - Use with DC voltage (current).
 - +B signals are input signals that exceed the $V_{\text{DD}5}$ voltage. +B signals should always be applied by connecting a limiting resistor between the +B signal and the microcontroller.
 - The value of the limiting resistor should be set so that the current input to the microcontroller pin does not exceed the rated value at any time, either instantaneously or for an extended period, when the +B signal is input.
 - Note that when the microcontroller drive current is low, such as in the low power consumption modes, the +B input potential can increase the potential at the power supply pin via a protective diode, possibly affecting other devices.
 - Note that if the +B signal is input when the microcontroller is off (not fixed at 0 V), power is supplied through the +B input pin; therefore, the microcontroller may partially operate.
 - Note that if the +B signal is input at power-on, since the power is supplied through the pin, the power-on reset may not function in the power supply voltage.

- Do not leave +B input pins open.
- Example of recommended circuit :

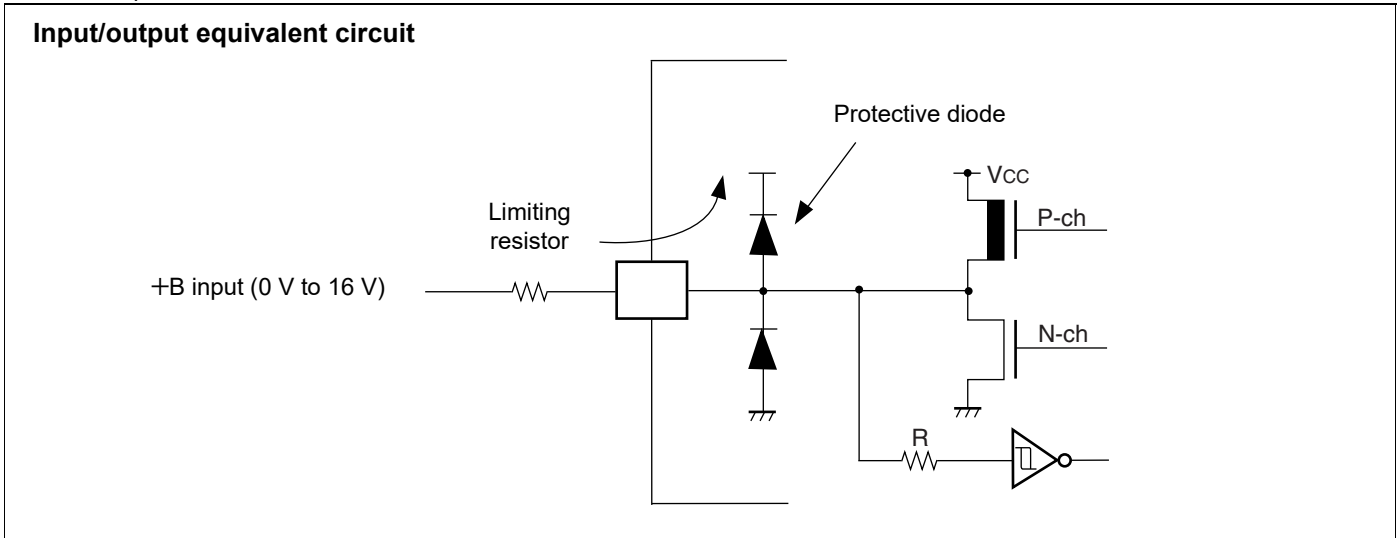

- *4 : Maximum output current is defined as the value of the peak current flowing through any one of the corresponding pins.
 - *5 : Average output current is defined as the value of the average current flowing through any one of the corresponding pins for a 100 ms period.
 - *6 : Total average output current is defined as the value of the average current flowing through all of the corresponding pins for a 100 ms period.
 - *7 : The maximum permitted power dissipation depends on the ambient temperature, the air flow velocity and the thermal conductance of the package on the PCB.
The actual power dissipation depends on the customer application and can be calculated as follows:

$$P_D = P_{IO} + P_{INT}$$

$$P_{IO} = \sum (V_{OL} * I_{OL} + V_{OH} * I_{OH})$$
 (IO load power dissipation, sum is performed on all IO ports)

$$P_{INT} = V_{DD}5R * I_{CC} + AV_{CC}5 * IA + AVRH5 * IR$$
 (internal power dissipation)
 - *8 : Worst case value for the QFP package mounted on a 4-layer PCB at specified TA without air flow.
 - *9 : Please contact Fujitsu for reliability limitations when using under these conditions.
- WARNING:** Semiconductor devices can be permanently damaged by application of stress (voltage, current, temperature, etc.) in excess of absolute maximum ratings. Do not exceed these ratings.

15.2 Recommended Operating Conditions

 ($V_{SS5} = AV_{SS5} = 0.0\text{ V}$)

Parameter	Symbol	Value			Unit	Remarks
		Min	Typ	Max		
Power supply voltage	V_{DD5}	3.0	—	5.5	V	
	V_{DD5R}	3.0	—	5.5	V	Internal regulator
	AV_{CC5}	3.0	—	5.5	V	A/D converter
Smoothing capacitor at VCC18C pin	C_S	—	4.7	—	μF	Use a X7R ceramic capacitor or a capacitor that has similar frequency characteristics.
Power supply slew rate		—	—	50	V/ms	
Operating temperature	T_A	- 40	—	+ 125	$^{\circ}\text{C}$	
Main Oscillation stabilisation time		10			ms	
Lock-up time PLL (4 MHz ->16 ...100MHz)				0.6	ms	
ESD Protection (Human body model)	Vsurge	2			kV	$R_{\text{discharge}} = 1.5\text{ k}\Omega$ $C_{\text{discharge}} = 100\text{ pF}$
RC Oscillator	$f_{RC100kHz}$ f_{RC2MHz}	50 1	100 2	200 4	kHZ MHZ	$V_{DD\text{CORE}} \geq 1.65\text{ V}$

WARNING: The recommended operating conditions are required in order to ensure the normal operation of the semiconductor device. All of the device's electrical characteristics are warranted when the device is operated within these ranges. Always use semiconductor devices within their recommended operating condition ranges. Operation outside these ranges may adversely affect reliability and could result in device failure. No warranty is made with respect to uses, operating conditions, or combinations not represented on the data sheet. Users considering application outside the listed conditions are advised to contact their representatives beforehand.

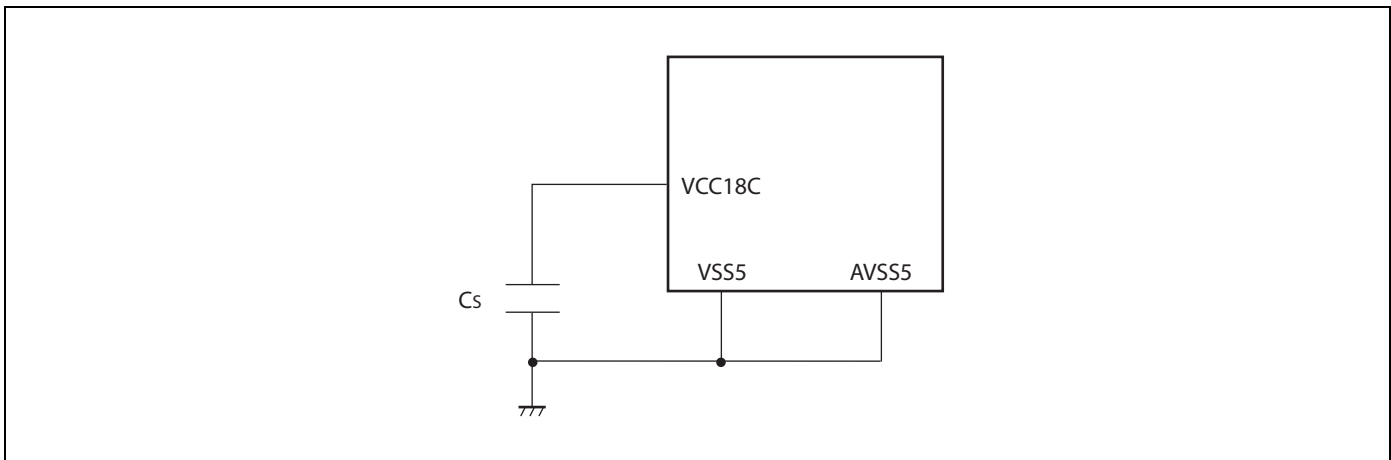

15.3 DC Characteristics
 $(V_{DD5} = AV_{CC5} = 3.0\text{ V to } 5.5\text{ V}, V_{SS5} = AV_{SS5} = 0\text{ V}, T_A = -40\text{ }^\circ\text{C to } +125\text{ }^\circ\text{C})$

Parameter	Symbol	Pin name	Condition	Value			Unit	Remarks
				Min	Typ	Max		
Input "H" voltage	V_{IH}	—	Port inputs if CMOS Hysteresis 0.8/0.2 input is selected	$0.8 \times V_{DD}$	—	$V_{DD} + 0.3$	V	CMOS hysteresis input
		—	Port inputs if CMOS Hysteresis 0.7/0.3 input is selected	$0.7 \times V_{DD}$	—	$V_{DD} + 0.3$	V	$4.5\text{ V} \leq V_{DD} \leq 5.5\text{ V}$
				$0.74 \times V_{DD}$	—	$V_{DD} + 0.3$	V	$3\text{ V} \leq V_{DD} < 4.5\text{ V}$
		—	AUTOMOTIVE Hysteresis input is selected	$0.8 \times V_{DD}$	—	$V_{DD} + 0.3$	V	
	—	Port inputs if TTL input is selected	2.0	—	$V_{DD} + 0.3$	V		
	V_{IHR}	INITX	—	$0.8 \times V_{DD}$	—	$V_{DD} + 0.3$	V	INITX input pin (CMOS Hysteresis)
	V_{IHM}	MD_3 to MD_0	—	$V_{DD} - 0.3$	—	$V_{DD} + 0.3$	V	Mode input pins
	V_{IHX0S}	X0, X0A	—	2.5	—	$V_{DD} + 0.3$	V	External clock in "Oscillation mode"
V_{IHX0F}	X0	—	$0.8 \times V_{DD}$	—	$V_{DD} + 0.3$	V	External clock in "Fast Clock Input mode"	
Input "L" voltage	V_{IL}	—	Port inputs if CMOS Hysteresis 0.8/0.2 input is selected	$V_{SS} - 0.3$	—	$0.2 \times V_{DD}$	V	
		—	Port inputs if CMOS Hysteresis 0.7/0.3 input is selected	$V_{SS} - 0.3$	—	$0.3 \times V_{DD}$	V	
				—	Port inputs if AUTOMOTIVE Hysteresis input is selected	$V_{SS} - 0.3$	—	$0.5 \times V_{DD}$
		$V_{SS} - 0.3$	—			$0.46 \times V_{DD}$	V	$3\text{ V} \leq V_{DD} < 4.5\text{ V}$
	—	Port inputs if TTL input is selected	$V_{SS} - 0.3$	—	0.8	V		
	V_{ILR}	INITX	—	$V_{SS} - 0.3$	—	$0.2 \times V_{DD}$	V	INITX input pin (CMOS Hysteresis)
	V_{ILM}	MD_3 to MD_0	—	$V_{SS} - 0.3$	—	$V_{SS} + 0.3$	V	Mode input pins
	V_{ILXDS}	X0, X0A	—	$V_{SS} - 0.3$	—	0.5	V	External clock in "Oscillation mode"
Input "L" voltage	V_{ILXDF}	X0	—	$V_{SS} - 0.3$	—	$0.2 \times V_{DD}$	V	External clock in "Fast Clock Input mode"

Parameter	Symbol	Pin name	Condition	Value			Unit	Remarks
				Min	Typ	Max		
Output "H" voltage	V _{OH2}	Normal outputs	4.5V ≤ V _{DD} ≤ 5.5V, I _{OH} = - 2mA	V _{DD} - 0.5	—	—	V	Driving strength set to 2 mA
			3.0V ≤ V _{DD} < 4.5V, I _{OH} = - 1.6mA					
	V _{OH5}	Normal outputs	4.5V ≤ V _{DD} ≤ 5.5V, I _{OH} = - 5mA	V _{DD} - 0.5	—	—	V	Driving strength set to 5 mA
3.0V ≤ V _{DD} < 4.5V, I _{OH} = - 3mA								
V _{OH3}	I ² C outputs	3.0V ≤ V _{DD} ≤ 5.5V, I _{OH} = - 3mA	V _{DD} - 0.5	—	—	V		
Output "L" voltage	V _{OL2}	Normal outputs	4.5V ≤ V _{DD} ≤ 5.5V, I _{OL} = + 2mA	—	—	0.4	V	Driving strength set to 2 mA
			3.0V ≤ V _{DD} < 4.5V, I _{OL} = + 1.6mA					
	V _{OL5}	Normal outputs	4.5V ≤ V _{DD} ≤ 5.5V, I _{OL} = + 5mA	—	—	0.4	V	Driving strength set to 5 mA
3.0V ≤ V _{DD} < 4.5V, I _{OL} = + 3mA								
V _{OL3}	I ² C outputs	3.0V ≤ V _{DD} ≤ 5.5V, I _{OL} = + 3mA	—	—	0.4	V		
Input leakage current	I _{IL}	Pnn_m*1	3.0V ≤ V _{DD} ≤ 5.5V V _{SS5} < V _I < V _{DD} T _A =25 °C	- 1	—	+ 1	μA	
			3.0V ≤ V _{DD} ≤ 5.5V V _{SS5} < V _I < V _{DD} T _A =125 °C	- 3	—	+ 3		
Analog input leakage current	I _{AIN}	ANn*2	3.0V ≤ V _{DD} ≤ 5.5V T _A =25 °C	- 1	—	+ 1	μA	
			3.0V ≤ V _{DD} ≤ 5.5V T _A =125 °C	- 3	—	+ 3	μA	
Pull-up resistance	R _{UP}	Pnn_m*3 INITX	3.0V ≤ V _{DD} ≤ 3.6V	40	100	160	kΩ	
			4.5V ≤ V _{DD} ≤ 5.5V	25	50	100		
Pull-down resistance	R _{DOWN}	Pnn_m*4	3.0V ≤ V _{DD} ≤ 3.6V	40	100	180	kΩ	
			4.5V ≤ V _{DD} ≤ 5.5V	25	50	100		
Input capacitance	C _{IN}	All except V _{DD5} , V _{DD5R} , V _{SS5} , AV _{CC5} , AV _{SS5} , AV _{RH5}	f = 1 MHz	—	5	15	pF	

Parameter	Symbol	Pin name	Condition	Value			Unit	Remarks
				Min	Typ	Max		
Power supply current CY91F464HB	I _{CC}	V _{DD5R}	CLKB: 100 MHz CLKP: 50 MHz CLKT: 50 MHz CLKCAN: 50 MHz	—	100	130	mA	Code fetch from Flash
	I _{CC} H	V _{DD5R}	T _A = + 25 °C	—	30	150	μA	At stop mode*5
			T _A = + 105 °C	—	0.3	2.0	mA	
			T _A = + 125 °C	—	0.75	5.0	mA	
	I _{CC} H	V _{DD5R}	T _A = + 25 °C	—	100	500	μA	RTC : 4 MHz mode*5
			T _A = + 105 °C	—	0.5	2.4	mA	
T _A = + 125 °C			—	0.85	5.4	mA		
I _{CC} H	V _{DD5R}	T _A = + 25 °C	—	50	250	μA	RTC : 100 kHz mode*5	
		T _A = + 105 °C	—	0.4	2.2	mA		
		T _A = + 125 °C	—	0.8	5.2	mA		
I _{LVI}	V _{DD5R}	—	—	50	100	μA	Internal low voltage detection	
I _{OSC}	V _{DD5}	—	—	250	500	μA	Main clock (4 MHz)	
		—	—	20	40	μA	Sub clock (32 kHz)	
Power supply current CY91F466HA	I _{CC}	V _{DD5R}	CLKB: 96 MHz CLKP: 48 MHz CLKT: 48 MHz CLKCAN: 48 MHz	—	110	140	mA	Code fetch from Flash
	I _{CC} H	V _{DD5R}	T _A = + 25 °C	—	30	150	μA	At stop mode*5
			T _A = + 105 °C	—	0.4	2.0	mA	
			T _A = + 125 °C	—	1.0	5.0	mA	
	I _{CC} H	V _{DD5R}	T _A = + 25 °C	—	100	500	μA	RTC : 4 MHz mode*5
			T _A = + 105 °C	—	0.5	2.4	mA	
T _A = + 125 °C			—	1.1	5.4	mA		
I _{CC} H	V _{DD5R}	T _A = + 25 °C	—	50	250	μA	RTC : 100 kHz mode*5	
		T _A = + 105 °C	—	0.45	2.2	mA		
		T _A = + 125 °C	—	1.05	5.2	mA		
I _{LVE}	V _{DD5}	—	—	70	150	μA	External low voltage detection	
I _{LVI}	V _{DD5R}	—	—	50	100	μA	Internal low voltage detection	
I _{OSC}	V _{DD5}	—	—	250	500	μA	Main clock (4 MHz)	
		—	—	20	40	μA	Sub clock (32 kHz)	

*1. Pnn_m includes all GPIO pins. Analog (AN) channels and PullUp/PullDown are disabled.

*2. ANn includes all pins where AN channels are enabled.

*3. Pnn_m includes all GPIO pins. The pull up resistors must be enabled by PPER/PPCR setting and the pins must be in input direction.

*4. Pnn_m includes all GPIO pins. The pull down resistors must be enabled by PPER/PPCR setting and the pins must be in input direction.

*5. Main regulator OFF, sub regulator set to 1.2V, Low voltage detection disabled.

15.4 A/D Converter Characteristics
 $(V_{DD5} = AV_{CC5} = 3.0\text{ V to }5.5\text{ V}, V_{SS5} = AV_{SS5} = 0\text{ V}, T_A = -40^\circ\text{C to }+125^\circ\text{C})$

Parameter	Symbol	Pin name	Value			Unit	Remarks
			Min	Typ	Max		
Resolution	—	—	—	—	10	bit	
Total error	—	—	- 3	—	+ 3	LSB	
Nonlinearity error	—	—	- 2.5	—	+ 2.5	LSB	
Differential nonlinearity error	—	—	- 1.9	—	+ 1.9	LSB	
Zero reading voltage	V_{OT}	ANn	AVRL-1.5	AVRL + 0.5	AVRL + 2.5	LSB	
Full scale reading voltage	V_{FST}	ANn	AVRH-3.5	AVRH-1.5	AVRH + 0.5	LSB	
Compare time	T_{comp}	—	0.6	—	16,500	μs	$4.5\text{ V} \leq AV_{CC5} \leq 5.5\text{ V}$
			2.0	—	—	μs	$3.0\text{ V} \leq AV_{CC5} \leq 4.5\text{ V}$
Sampling time	T_{samp}	—	0.4	—	—	μs	$4.5\text{ V} \leq AV_{CC5} \leq 5.5\text{ V}$, $R_{EXT} < 2\text{ k}\Omega$
			1.0	—	—	μs	$3.0\text{ V} \leq AV_{CC5} \leq 4.5\text{ V}$, $R_{EXT} < 1\text{ k}\Omega$
Conversion time	T_{conv}	—	1.0	—	—	μs	$4.5\text{ V} \leq AV_{CC5} \leq 5.5\text{ V}$
			3.0	—	—	μs	$3.0\text{ V} \leq AV_{CC5} \leq 4.5\text{ V}$
Input capacitance	C_{IN}	ANn	—	—	11	pF	
Input resistance	R_{IN}	ANn	—	—	2.6	k Ω	$4.5\text{ V} \leq AV_{CC5} \leq 5.5\text{ V}$
			—	—	12.1	k Ω	$3.0\text{ V} \leq AV_{CC5} \leq 4.5\text{ V}$
Analog input leakage current	I_{AIN}	ANn	- 1	—	+ 1	μA	$T_A = +25^\circ\text{C}$
			- 3	—	+ 3	μA	$T_A = +125^\circ\text{C}$
Analog input voltage range	V_{AIN}	ANn	AVRL	—	AVRH	V	
Offset between input channels	—	ANn	—	—	4	LSB	
			—	—	—	—	—
Reference voltage range	AVRH	AVRH5	$0.75 \times AV_{CC5}$	—	AV_{CC5}	V	
	AVRL	AVSS5	AV_{SS5}	—	$AV_{CC5} \times 0.25$	V	
Power supply current per ADC macro *3	I_A	AV_{CC5}	—	2.5	5	mA	A/D Converter active
	I_{AH}	AV_{CC5}	—	—	5	μA	A/D Converter not operated *1
Reference voltage current per ADC macro *3	I_R	AVRH5	—	0.7	1	mA	A/D Converter active
	I_{RH}	AVRH5	—	—	5	μA	A/D Converter not operated *2

Note : The accuracy gets worse as AVRH - AVRL becomes smaller

*1 : Supply current at AV_{CC5} , if A/D converter and ALARM comparator are not operating, ($V_{DD5} = AV_{CC5} = AVRH = 5.0\text{ V}$)

*2 : Input current at AVRH5, if A/D converter is not operating, ($V_{DD5} = AV_{CC5} = AVRH = 5.0\text{ V}$)

*3 : The current consumption per ADC macro is given here. On devices having more than one A/D converter, the current values have to be multiplied by the number of macros.

Sampling Time Calculation

$$T_{\text{samp}} = (2.6 \text{ k}\Omega + R_{\text{EXT}}) \times 11 \text{ pF} \times 7; \text{ for } 4.5\text{V} \leq AV_{\text{CC5}} \leq 5.5\text{V}$$

$$T_{\text{samp}} = (12.1 \text{ k}\Omega + R_{\text{EXT}}) \times 11 \text{ pF} \times 7; \text{ for } 3.0\text{V} \leq AV_{\text{CC5}} < 4.5\text{V}$$

Conversion Time Calculation

$$T_{\text{conv}} = T_{\text{samp}} + T_{\text{comp}}$$

Definition of A/D converter terms

■ Resolution

Analog variation that is recognizable by the A/D converter.

■ Nonlinearity error

Deviation between actual conversion characteristics and a straight line connecting the zero transition point (00 0000 0000_B ↔ 00 0000 0001_B) and the full scale transition point (11 1111 1110_B ↔ 11 1111 1111_B).

■ Differential nonlinearity error

Deviation of the input voltage from the ideal value that is required to change the output code by 1 LSB.

■ Total error

This error indicates the difference between actual and theoretical values, including the zero transition error, full scale transition error, and nonlinearity error.

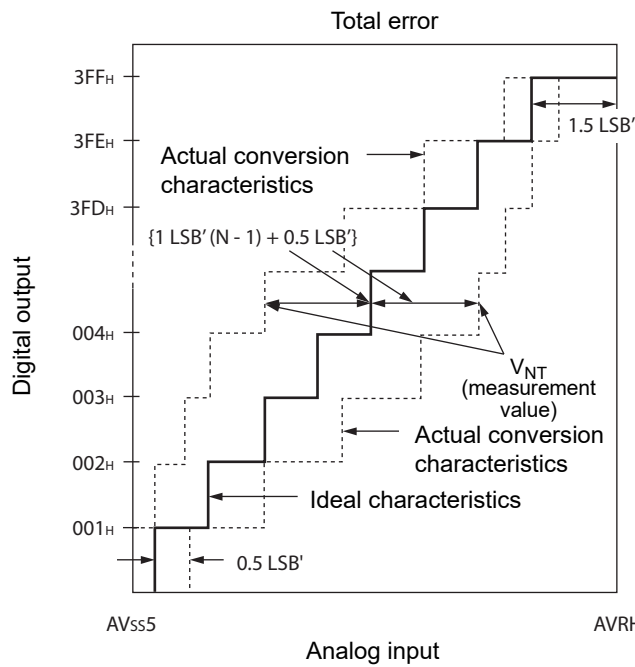

$$1\text{LSB}' (\text{ideal value}) = \frac{\text{AVRH} - \text{AV}_{\text{SS5}}}{1024} \text{ [V]}$$

$$\text{Total error of digital output } N = \frac{V_{\text{NT}} - \{1 \text{LSB}' \times (N - 1) + 0.5 \text{LSB}'\}}{1 \text{LSB}'}$$

N : A/D converter digital output value

V_{OT}' (ideal value) = $\text{AV}_{\text{SS5}} + 0.5 \text{LSB}'$ [V]

V_{FST}' (ideal value) = $\text{AVRH} - 1.5 \text{LSB}'$ [V]

V_{NT} : Voltage at which the digital output changes from $(N + 1)_{\text{H}}$ to N_{H}

(Continued)

(Continued)

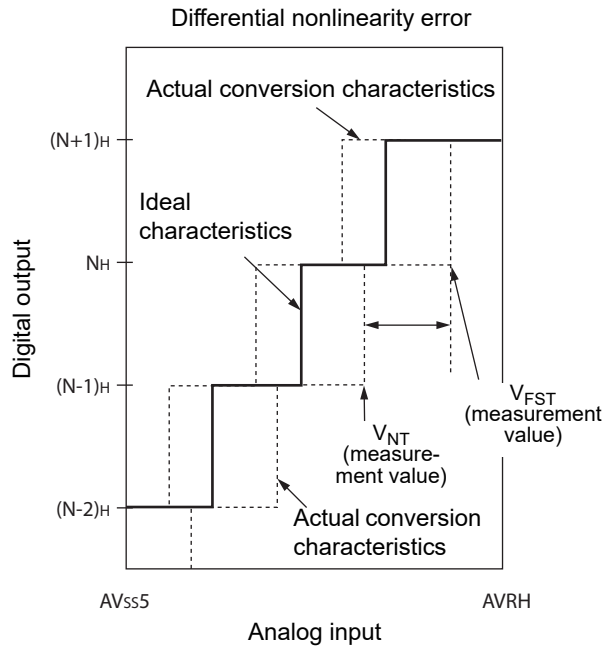
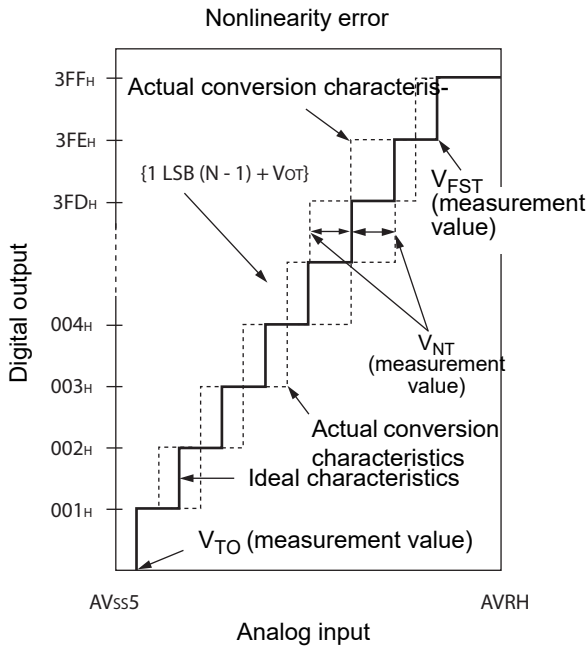

$$\text{Nonlinearity error of digital output } N = \frac{V_{NT} - \{1\text{LSB} \times (N - 1) + V_{OT}\}}{1\text{LSB}} \text{ [LSB]}$$

$$\text{Differential nonlinearity error of digital output } N = \frac{V_{(N+1)T} - V_{NT}}{1\text{LSB}} - 1 \text{ [LSB]}$$

$$1\text{LSB} = \frac{V_{FST} - V_{OT}}{1022} \text{ [V]}$$

N : A/D converter digital output value

V_{OT} : Voltage at which the digital output changes from 000_H to 001_H.

V_{FST} : Voltage at which the digital output changes from 3FE_H to 3FF_H.

15.5 Alarm Comparator Characteristics

Parameter	Symbol	Pin name	Value			Unit	Remarks
			Min	Typ	Max		
Power supply current	I_{A5ALMF}	AV_{CC5}	—	25	40	μA	Alarm comparator enabled in fast mode (per channel) *1
	I_{A5ALMS}		—	7	10	μA	Alarm comparator enabled in normal mode (per channel) *1
	I_{A5ALMH}		—	—	5	μA	Alarm comparator disabled
ALARM pin input current	I_{ALIN}	ALARM_n	- 1	—	+ 1	μA	$T_A=25\text{ }^\circ C$
			- 3	—	+ 3	μA	$T_A=125\text{ }^\circ C$
ALARM pin input voltage range	V_{ALIN}		0	—	AV_{CC5}	V	
Alarm upper limit voltage	V_{IAH}		$AV_{CC5} \times 0.78$ - 3%	$AV_{CC5} \times 0.78$	$AV_{CC5} \times 0.78$ + 3%	V	
Alarm lower limit voltage	V_{IAL}		$AV_{CC5} \times 0.36$ - 5%	$AV_{CC5} \times 0.36$	$AV_{CC5} \times 0.36$ + 5%	V	
Alarm hysteresis voltage	V_{IAHYS}		50	—	250	mV	
Alarm input resistance	R_{IN}		5	—	—	$M\Omega$	
Comparison time	t_{COMPF}		—	0.1	0.2	μs	Alarm comparator enabled in fast mode *1
	t_{COMPS}	—	1	2	μs	Alarm comparator enabled in normal mode *1	

Note: *1: The fast Alarm Comparator mode is enabled by setting ACSR.MD=1
Setting ACSR.MD=0 sets the normal mode.

15.6 FLASH Memory Program/Erase Characteristics
15.6.1 CY91F464HB
 $(V_{DD5} = 3.0\text{ V to }5.5\text{ V}, V_{DD5R} = 3.0\text{ V to }5.5\text{ V}, V_{SS5} = 0\text{ V}, T_A = -40\text{ }^{\circ}\text{C to }+105\text{ }^{\circ}\text{C})$

Parameter	Value			Unit	Remarks
	Min	Typ	Max		
Sector erase time	-	0.9	3.6	s	Erasure programming time not included
Chip erase time	-	n*0.9	n*3.6	s	n is the number of Flash sector of the device
Word (16-bit or 32-bit width) programming time	-	23	370	μs	System overhead time not included
Program/Erase cycle	10 000			cycle	
Flash data retention time	20			year	*1

*1. This value was converted from the results of evaluating the reliability of the technology (using Arrhenius equation to convert high temperature measurements into normalized value at 85 °C)

15.6.2 CY91F466HA
 $(V_{DD5} = 3.0\text{ V to }5.5\text{ V}, V_{DD5R} = 3.0\text{ V to }5.5\text{ V}, V_{SS5} = 0\text{ V}, T_A = -40\text{ }^{\circ}\text{C to }+105\text{ }^{\circ}\text{C})$

Parameter	Value			Unit	Remarks
	Min	Typ	Max		
Sector erase time	-	0.5	2.0	s	Erasure programming time not included
Chip erase time	-	n*0.5	n*2.0	s	n is the number of Flash sector of the device
Word (16-bit or 32-bit width) programming time	-	6	100	μs	System overhead time not included
Program/Erase cycle	10 000			cycle	
Flash data retention time	20			year	*1

*1. This value was converted from the results of evaluating the reliability of the technology (using Arrhenius equation to convert high temperature measurements into normalized value at 85 °C)

15.7 AC Characteristics

15.7.1 Clock Timing

($V_{DD5} = 3.0\text{ V to } 5.5\text{ V}$, $V_{SS5} = AV_{SS5} = 0\text{ V}$, $T_A = -40\text{ }^\circ\text{C to } +125\text{ }^\circ\text{C}$)

Parameter	Symbol	Pin name	Value			Unit	Condition
			Min	Typ	Max		
Clock frequency	f_C	X0 X1	3.5	4	16	MHz	Opposite phase external supply or crystal
		X0A X1A	32	32.768	100	kHz	

Clock timing condition

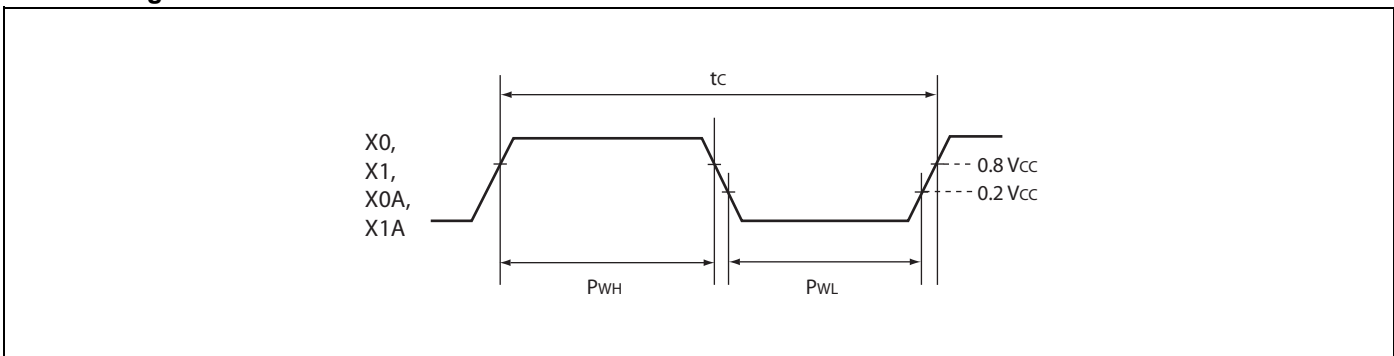

15.7.2 Reset Input Ratings

($V_{DD5} = 3.0\text{ V to } 5.5\text{ V}$, $V_{SS5} = AV_{SS5} = 0\text{ V}$, $T_A = -40\text{ }^\circ\text{C to } +125\text{ }^\circ\text{C}$)

Parameter	Symbol	Pin name	Condition	Value		Unit
				Min	Max	
INITX input time (at power-on)	t_{INTL}	INITX	—	8	—	ms
INITX input time (other than the above)				20	—	μs

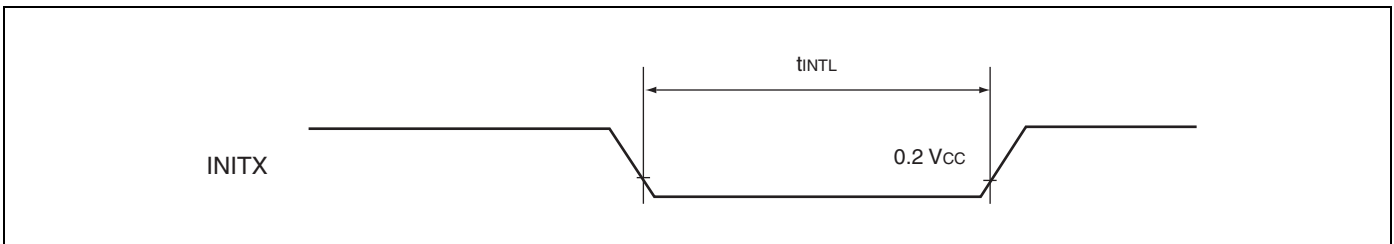

15.7.3 LIN-USART Timings at $V_{DD5} = 3.0$ to 5.5 V

- Conditions during AC measurements

All AC tests were measured under the following conditions:

- $I_{Odrive} = 5$ mA
- $V_{DD5} = 3.0$ V to 5.5 V, $I_{load} = 3$ mA
- $V_{SS5} = 0$ V
- $T_a = -40$ °C to $+125$ °C
- $C_l = 50$ pF (load capacity value of pins when testing)
- $V_{OL} = 0.2 \times V_{DD5}$
- $V_{OH} = 0.8 \times V_{DD5}$
- EPILR = 0, PILR = 1 (Automotive Level = worst case)

($V_{DD5} = 3.0$ V to 5.5 V, $V_{SS5} = AV_{SS5} = 0$ V, $T_A = -40$ °C to $+125$ °C)

Parameter	Symbol	Pin name	Condition	$V_{DD5} = 3.0$ V to 4.5 V		$V_{DD5} = 4.5$ V to 5.5 V		Unit
				Min	Max	Min	Max	
Serial clock cycle time	t_{SCYCI}	SCKn	Internal clock operation (master mode)	$4 t_{CLKP}$	—	$4 t_{CLKP}$	—	ns
SCK ↓ → SOT delay time	t_{SLOVI}	SCKn SOTn		- 30	30	- 20	20	ns
SOT → SCK ↓ delay time	t_{OVSHI}	SCKn SOTn		$m \times t_{CLKP} - 30^*$	—	$m \times t_{CLKP} - 20^*$	—	ns
Valid SIN → SCK ↑ setup time	t_{IVSHI}	SCKn SINn		$t_{CLKP} + 55$	—	$t_{CLKP} + 45$	—	ns
SCK ↑ → valid SIN hold time	t_{SHIXI}	SCKn SINn		0	—	0	—	ns
Serial clock "H" pulse width	t_{SHSLE}	SCKn	External clock operation (slave mode)	$t_{CLKP} + 10$	—	$t_{CLKP} + 10$	—	ns
Serial clock "L" pulse width	t_{SLSHE}	SCKn		$t_{CLKP} + 10$	—	$t_{CLKP} + 10$	—	ns
SCK ↓ → SOT delay time	t_{SLOVE}	SCKn SOTn		—	$2 t_{CLKP} + 55$	—	$2 t_{CLKP} + 45$	ns
Valid SIN → SCK ↑ setup time	t_{IVSHE}	SCKn SINn		10	—	10	—	ns
SCK ↑ → valid SIN hold time	t_{SHIXE}	SCKn SINn		$t_{CLKP} + 10$	—	$t_{CLKP} + 10$	—	ns
SCK rising time	t_{FE}	SCKn		—	20	—	20	ns
SCK falling time	t_{RE}	SCKn		—	20	—	20	ns

* : Parameter m depends on t_{SCYCI} and can be calculated as :

- if $t_{SCYCI} = 2 \times k \times t_{CLKP}$, then $m = k$, where k is an integer > 2
- if $t_{SCYCI} = (2 \times k + 1) \times t_{CLKP}$, then $m = k + 1$, where k is an integer > 1

Notes : • The above values are AC characteristics for CLK synchronous mode.

- t_{CLKP} is the cycle time of the peripheral clock.

Internal clock mode (master mode)

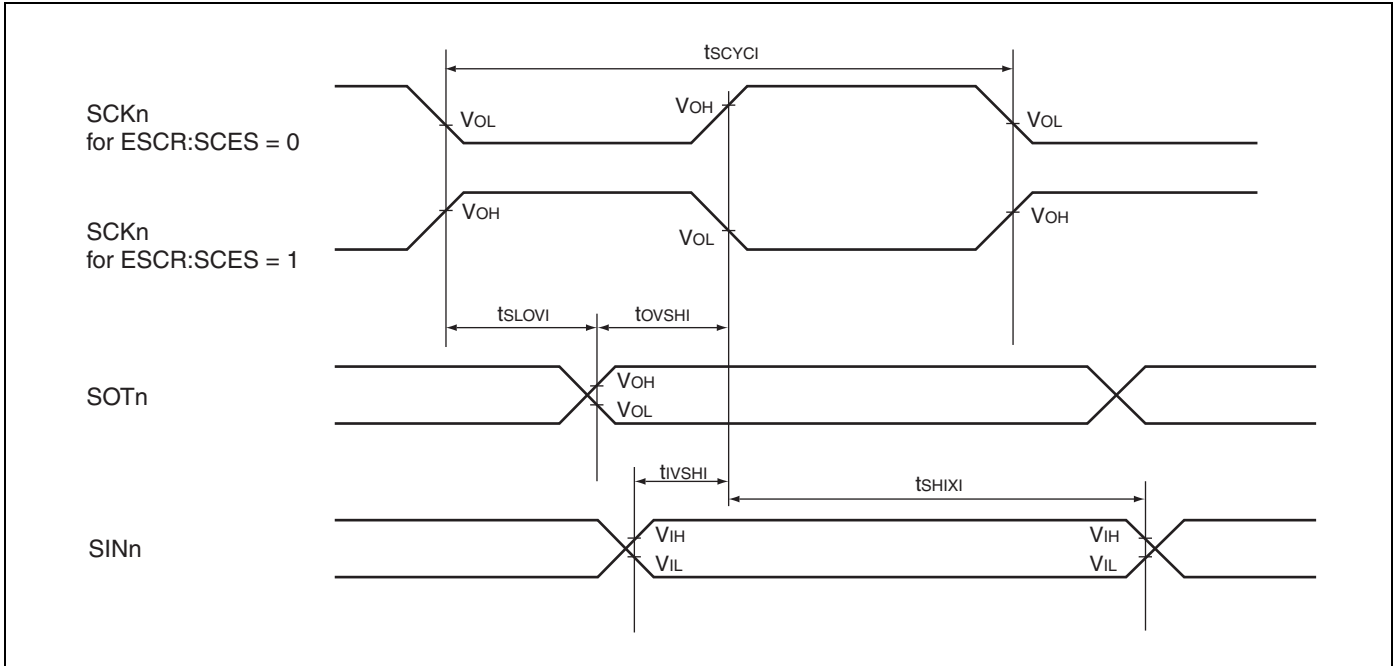

External clock mode (slave mode)

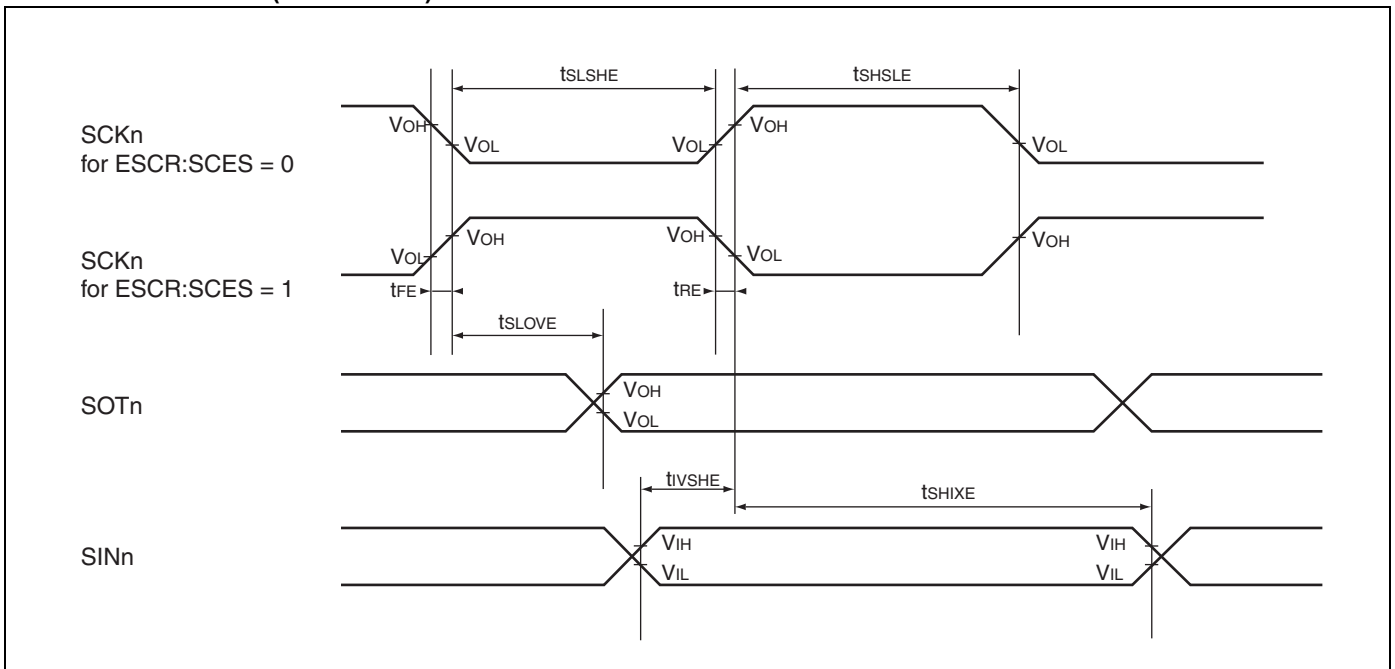

15.7.4 I²C AC Timings at V_{DD5} = 3.0 to 5.5 V

- Conditions during AC measurements

All AC tests were measured under the following conditions:

- I_{Odrive} = 3 mA
- V_{DD5} = 3.0 V to 5.5 V, I_{load} = 3 mA
- V_{SS5} = 0 V
- T_a = - 40 °C to + 125 °C
- C_l = 50 pF
- VOL = 0.3 × V_{DD5}
- VOH = 0.7 × V_{DD5}
- EPILR = 0, PILR = 0 (CMOS Hysteresis 0.3 × V_{DD5}/0.7 × V_{DD5})

Fast mode:

(V_{DD5} = 3.5 V to 5.5 V, V_{SS5} = AV_{SS5} = 0 V, T_A = -40 °C to + 125 °C)

Parameter	Symbol	Pin name	Value		Unit	Remark
			Min	Max		
SCL clock frequency	f _{SCL}	SCLn	0	400	kHz	
Hold time (repeated) START condition. After this period, the first clock pulse is generated	t _{HD;STA}	SCLn, SDAn	0.6	—	μs	
LOW period of the SCL clock	t _{LOW}	SCLn	1.3	—	μs	
HIGH period of the SCL clock	t _{HIGH}	SCLn	0.6	—	μs	
Setup time for a repeated START condition	t _{SU;STA}	SCLn, SDAn	0.6	—	μs	
Data hold time for I ² C-bus devices	t _{HD;DAT}	SCLn, SDAn	0	0.9	μs	
Data setup time	t _{SU;DAT}	SCLn, SDAn	100	—	ns	
Rise time of both SDA and SCL signals	t _r	SCLn, SDAn	20 + 0.1Cb	300	ns	
Fall time of both SDA and SCL signals	t _f	SCLn, SDAn	20 + 0.1Cb	300	ns	
Setup time for STOP condition	t _{SU;STO}	SCLn, SDAn	0.6	—	μs	
Bus free time between a STOP and START condition	t _{BUF}	SCLn, SDAn	1.3	—	μs	
Capacitive load for each bus line	C _b	SCLn, SDAn	—	400	pF	
Pulse width of spike suppressed by input filter	t _{SP}	SCLn, SDAn	0	(1..1.5) × t _{CLKP}	ns	*1

*1: The noise filter will suppress single spikes with a pulse width of 0ns and between (1 to 1.5) cycles of peripheral clock, depending on the phase relationship between I²C signals (SDA, SCL) and peripheral clock.

Note: t_{CLKP} is the cycle time of the peripheral clock.

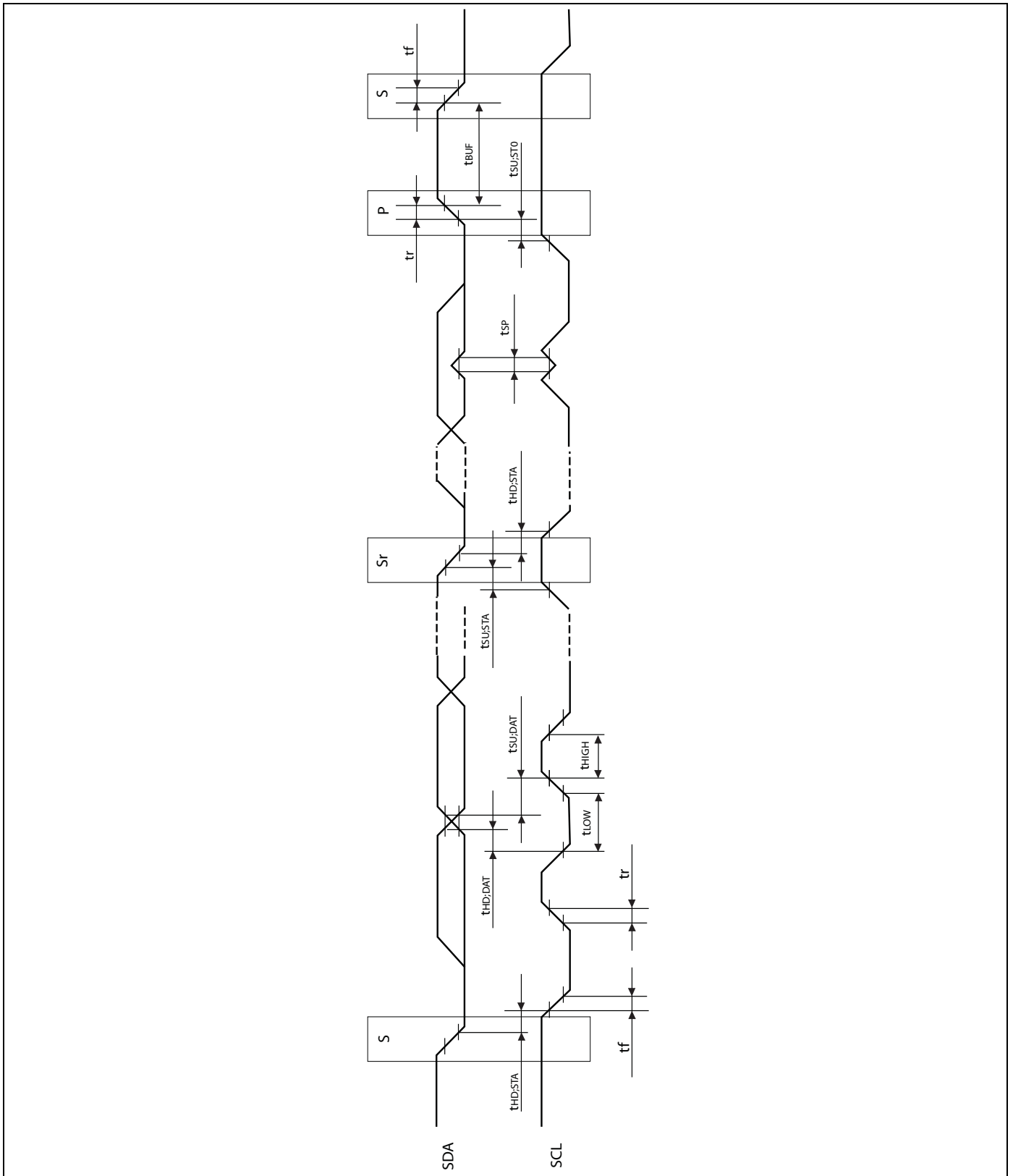

15.7.5 Free-run Timer Clock

($V_{DD5} = 3.0\text{ V to } 5.5\text{ V}$, $V_{SS5} = AV_{SS5} = 0\text{ V}$, $T_A = -40\text{ }^\circ\text{C to } +125\text{ }^\circ\text{C}$)

Parameter	Symbol	Pin name	Condition	Value		Unit
				Min	Max	
Input pulse width	t_{TIWH} t_{TIWL}	CKn	—	$4t_{CLKP}$	—	ns

Note : t_{CLKP} is the cycle time of the peripheral clock.

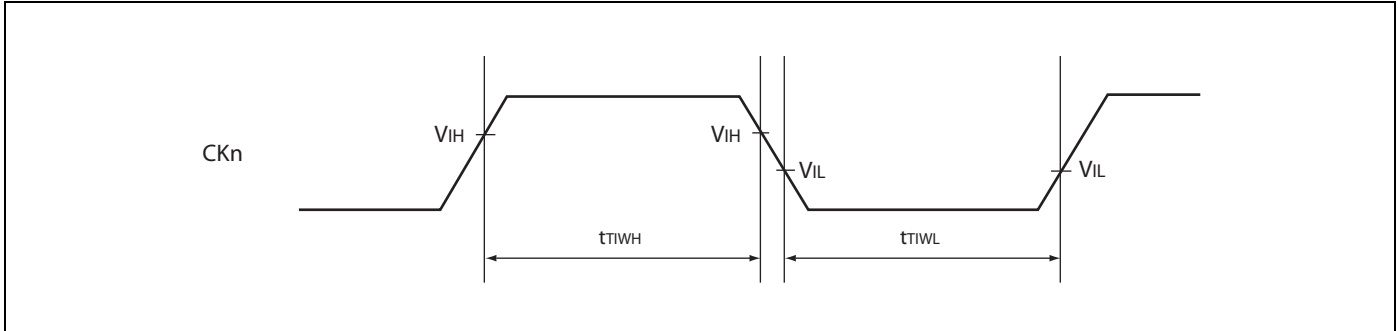

15.7.6 Trigger Input Timing

($V_{DD5} = 3.0\text{ V to } 5.5\text{ V}$, $V_{SS5} = AV_{SS5} = 0\text{ V}$, $T_A = -40\text{ }^\circ\text{C to } +125\text{ }^\circ\text{C}$)

Parameter	Symbol	Pin name	Condition	Value		Unit
				Min	Max	
Input capture input trigger	t_{INP}	ICUn	—	$5t_{CLKP}$	—	ns
A/D converter trigger	t_{ATGX}	ATGX	—	$5t_{CLKP}$	—	ns

Note : t_{CLKP} is the cycle time of the peripheral clock.

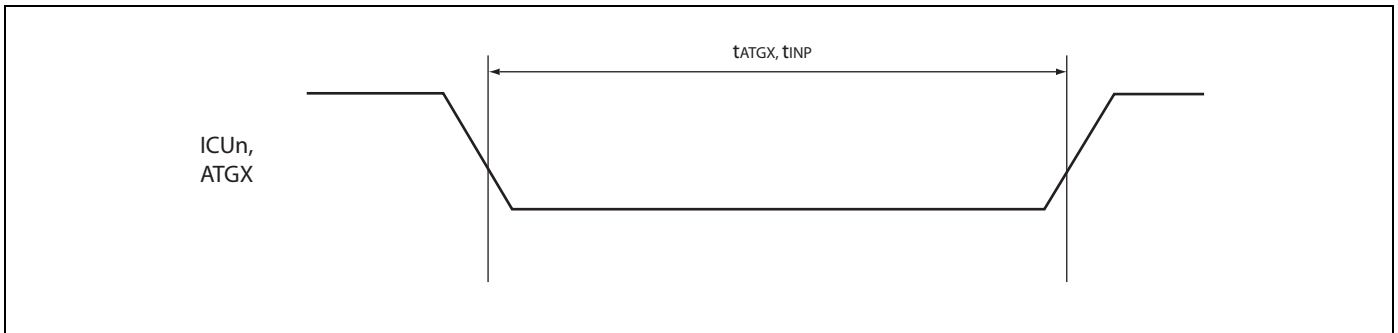

15.7.7 External Bus AC Timings at $V_{DD35} = 3.0$ to 5.5 V

- Conditions during AC measurements

All AC tests were measured under the following conditions:

- $I_{Odrive} = 5$ mA
- $V_{DD35} = 4.5$ V to 5.5 V, $I_{load} = 3$ mA
- $V_{SS5} = 0$ V
- $T_a = -40$ °C to $+125$ °C
- $C_1 = 50$ pF
- $VOL = 0.5 \times V_{DD35}$
- $VOH = 0.5 \times V_{DD35}$
- EPILR = 0, PILR = 1 (Automotive Level = worst case)

Basic Timing

($V_{DD35} = 3.0$ V to 5.5 V, $V_{SS5} = AV_{SS5} = 0$ V, $T_A = -40$ °C to $+125$ °C)

Parameter	Symbol	Pin name	Value		Unit
			Min	Max	
SYSCLK	t_{CLCH}	SYSCLK	$1/2 \times t_{CLKT} - 1$	$1/2 \times t_{CLKT} + 9$	ns
	t_{CHCL}		$1/2 \times t_{CLKT} - 9$	$1/2 \times t_{CLKT} + 1$	ns
SYSCLK ↓ to CSXn delay time	t_{CLCSL}	SYSCLK CSXn	—	8	ns
	t_{CLCSH}		—	12	ns
SYSCLK ↑ to CSXn delay time (Addr → CS delay)	t_{CHCSL}		- 6	+ 1	ns
SYSCLK ↓ to Address valid delay time	t_{CLAV}	SYSCLK A21 to A0	—	13	ns

Note : t_{CLKT} is the cycle time of the external bus clock.

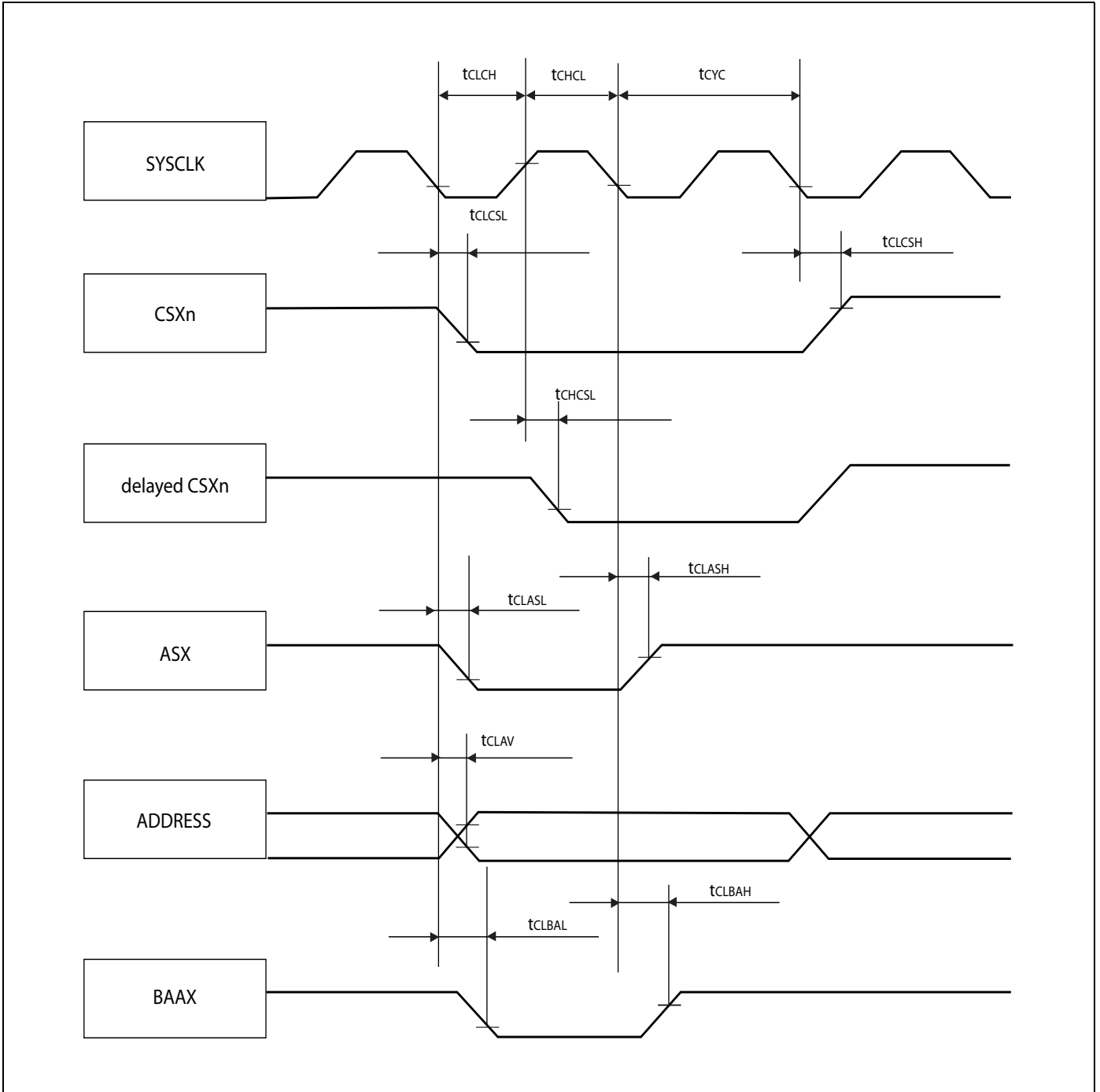

Synchronous/Asynchronous read access

($V_{DD35} = 3.0\text{ V to }5.5\text{ V}$, $V_{SS5} = AV_{SS5} = 0\text{ V}$, $T_A = -40\text{ }^\circ\text{C to }+125\text{ }^\circ\text{C}$)

Parameter	Symbol	Pin name	Value		Unit
			Min	Max	
SYSCLK \uparrow to RDX delay time	TCHRL	SYSCLK RDX	- 7	1	ns
	TCHRH		- 4	2	ns
Data valid to RDX \uparrow setup time	TDSRH	RDX D31 to D16	33	—	ns
RDX \uparrow to Data valid hold time	TRHDX	RDX D31 to D16	0	—	ns
SYSCLK \downarrow to WRXn (as byte enable) delay time	TCLWRL	SYSCLK WRXn	—	8	ns
	TCLWRH		0	—	ns
SYSCLK \downarrow to CSXn delay time	TCLCSL	SYSCLK CSXn	—	8	ns
	TCLCSH		—	12	ns

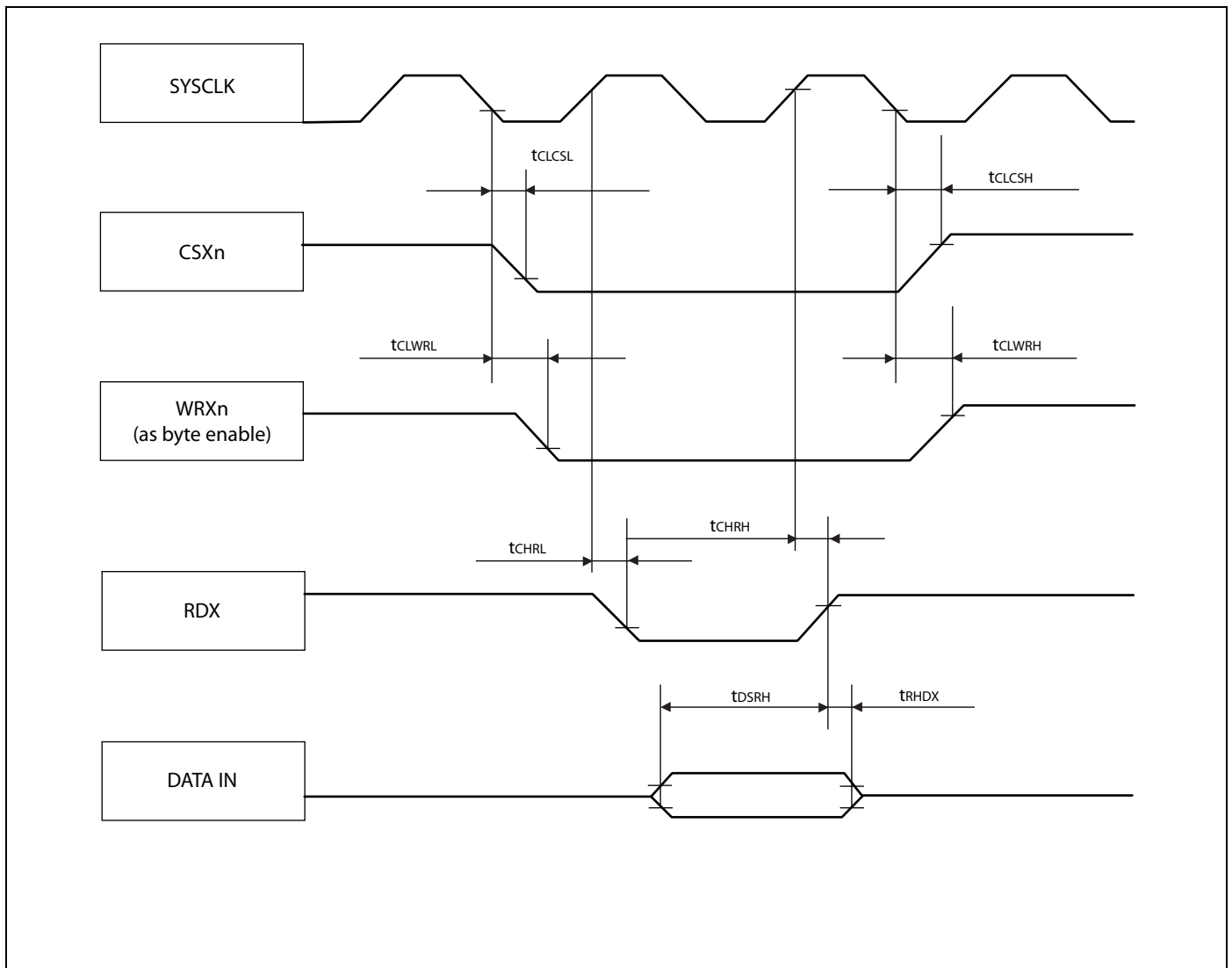

Synchronous write access

($V_{DD35} = 3.0\text{ V to }5.5\text{ V}$, $V_{SS5} = AV_{SS5} = 0\text{ V}$, $T_A = -40\text{ }^\circ\text{C to }+125\text{ }^\circ\text{C}$)

Parameter	Symbol	Pin name	Value		Unit
			Min	Max	
SYSCLK ↓ to WRXn delay time	TCLWRL	SYSCLK WRXn	—	8	ns
	TCLWRH		0	—	ns
Data valid to WRXn ↓ setup time	TDSWRL	WRXn D31 to D16	-7	—	ns
WRXn ↑ to Data valid hold time	TWRHDH	WRXn D31 to D16	$t_{CLKT} - 20$	—	ns
SYSCLK ↓ to CSXn delay time	TCLCSL	SYSCLK CSXn	—	8	ns
	TCLCSH		—	12	ns

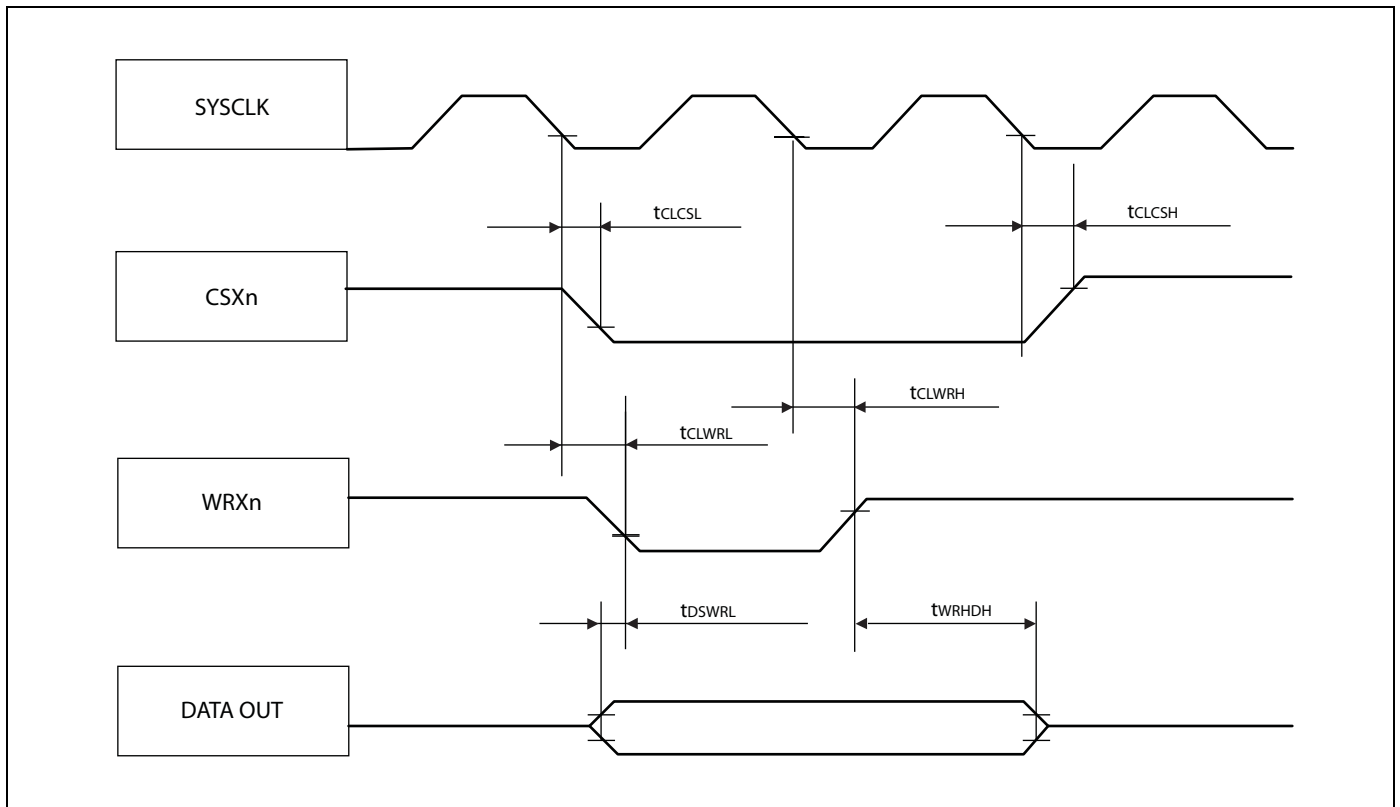

Asynchronous write access

($V_{DD35} = 3.0\text{ V to } 5.5\text{ V}$, $V_{SS5} = AV_{SS5} = 0\text{ V}$, $T_A = -40\text{ }^\circ\text{C to } +125\text{ }^\circ\text{C}$)

Parameter	Symbol	Pin name	Value		Unit
			Min	Max	
WRXn ↓ to WRXn ↑ pulse width	TWRLWRH	WRXn	t_{CLKT}	—	ns
Data valid to WRXn ↓ setup time	TDSWRL	WRXn D31 to D16	$1/2 \times t_{CLKT} - 10$	—	ns
WRXn ↑ to Data valid hold time	TWRHDH	WRXn D31 to D16	$1/2 \times t_{CLKT} - 19$	—	ns
WRXn to CSXn delay time	TCLWRL	WRXn CSXn	—	$1/2 \times t_{CLKT}$	ns
	TWRHCH		$1/2 \times t_{CLKT}$	—	ns

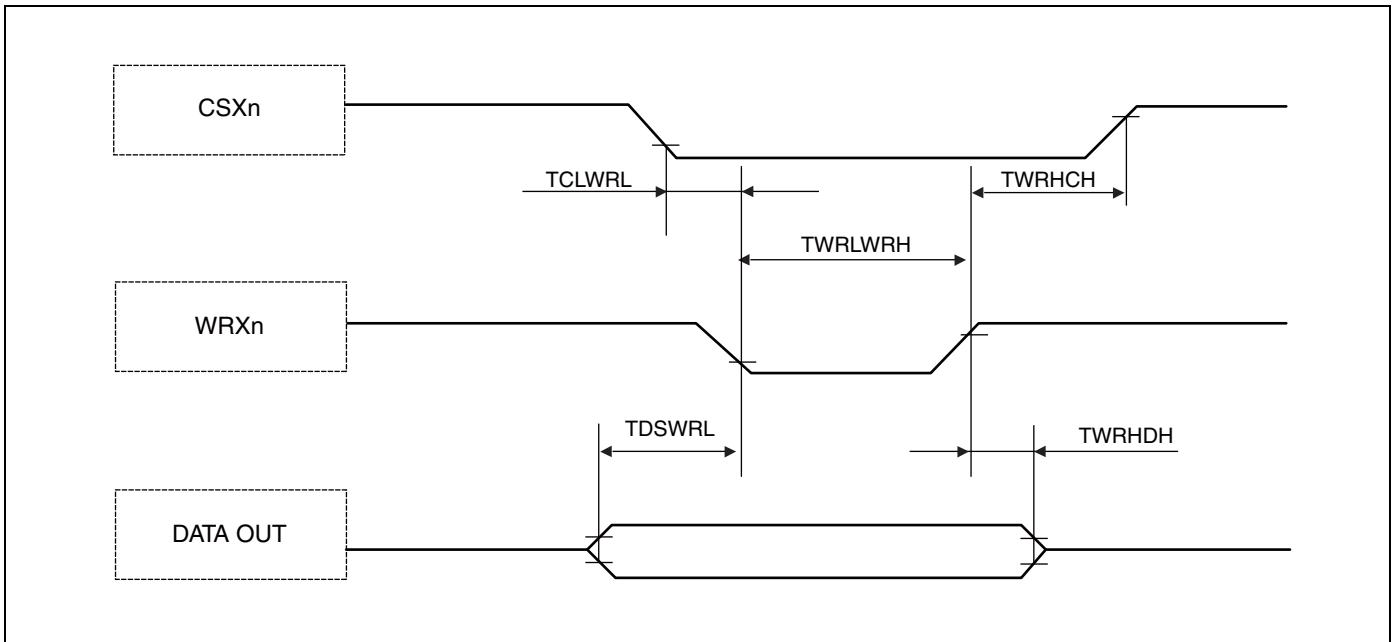

RDY waitcycle insertion

 ($V_{DD35} = 3.0\text{ V to }5.5\text{ V}$, $V_{SS5} = AV_{SS5} = 0\text{ V}$, $T_A = -40\text{ }^\circ\text{C to }+125\text{ }^\circ\text{C}$)

Parameter	Symbol	Pin name	Value		Unit
			Min	Max	
RDY setup time	TRDYS	SYSCLK RDY	34	—	ns
RDY hold time	TRDYH	SYSCLK RDY	0	—	ns

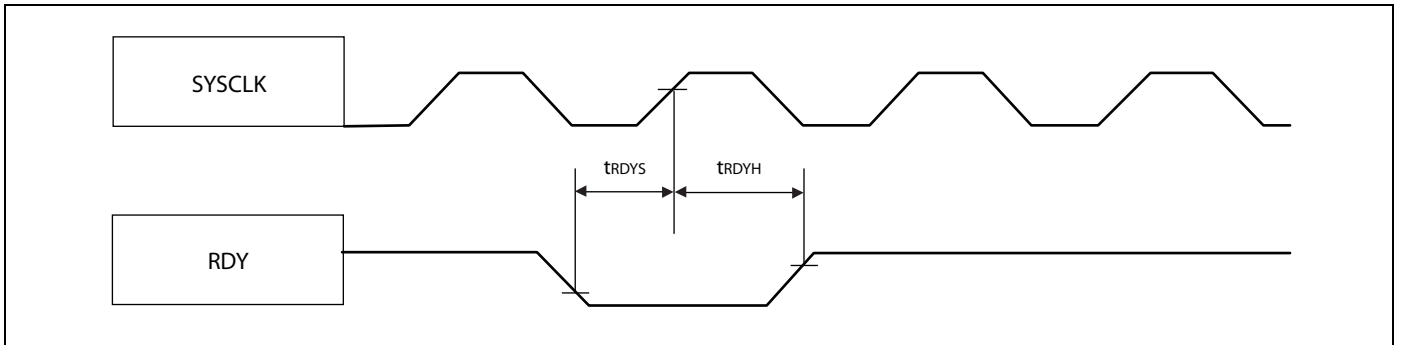

16. Ordering Information

Part Number	Package	Remarks
CY91F466HAPMC-GS-UJE2	144-pin plastic LQFP (LQS144)	Lead-free package

17. Package Dimension

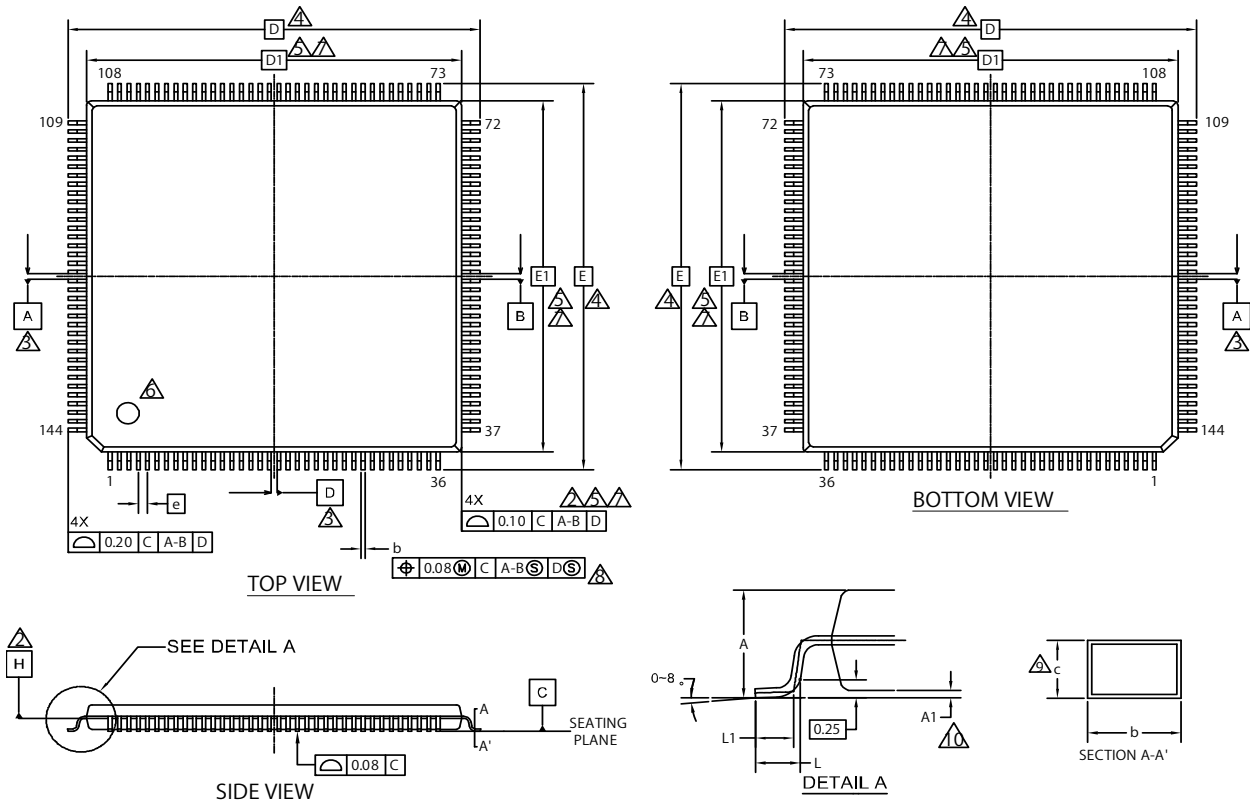

SYMBOL	DIMENSIONS		
	MIN.	NOM.	MAX.
A	—	—	1.70
A1	0.05	—	0.15
b	0.17	0.22	0.27
c	0.09	—	0.20
D	22.00 BSC		
D1	20.00 BSC		
e	0.50 BSC		
E	22.00 BSC		
E1	20.00 BSC		
L	0.45	0.60	0.75
L1	0.30	0.50	0.70

NOTES

- ALL DIMENSIONS ARE IN MILLIMETERS
- DATUM PLANE H IS LOCATED AT THE BOTTOM OF THE MOLD PARTING LINE COINCIDENT WITH WHERE THE LEAD EXITS THE BODY.
- DATUMS A-B AND D TO BE DETERMINED AT DATUM PLANE H.
- DATUMS A-B AND D TO BE DETERMINED AT SEATING PLANE C.
- DIMENSIONS D1 AND E1 DO NOT INCLUDE MOLD PROTRUSION. ALLOWABLE PROTRUSION IS 0.25mm PRE SIDE.
- DIMENSIONS D1 AND E1 INCLUDE MOLD MISMATCH AND ARE DETERMINED AT DATUM PLANE H.
- DETAILS OF PIN 1 IDENTIFIER ARE OPTIONAL BUT MUST BE LOCATED WITHIN THE ZONE INDICATED.
- REGARDLESS OF THE RELATIVE SIZE OF THE UPPER AND LOWER BODY SECTIONS. DIMENSIONS D1 AND E1 ARE DETERMINED AT THE LARGEST FEATURE OF THE BODY EXCLUSIVE OF MOLD FLASH AND GATE BURRS. BUT INCLUDING ANY MISMATCH BETWEEN THE UPPER AND LOWER SECTIONS OF THE MOLDER BODY.
- DIMENSION b DOES NOT INCLUDE DAMBAR PROTRUSION. THE DAMBAR PROTRUSION (S) SHALL NOT CAUSE THE LEAD WIDTH TO EXCEED b MAXIMUM BY MORE THAN 0.08mm. DAMBAR CANNOT BE LOCATED ON THE LOWER RADIUS OR THE LEAD FOOT.
- THESE DIMENSIONS APPLY TO THE FLAT SECTION OF THE LEAD BETWEEN 0.10mm AND 0.25mm FROM THE LEAD TIP.
- A1 IS DEFINED AS THE DISTANCE FROM THE SEATING PLANE TO THE LOWEST POINT OF THE PACKAGE BODY.

002-13015 *A

PACKAGE OUTLINE, 144 LEAD LQFP
20.0X20.0X1.7 MM LQS144 REV*A

18. Revision History

Version	Date	Remark
2.0	2009-01-07	Initial version

19. Major Changes

Spanion Publication Number: DS07-16616-1E

Page	Section	Change Results
87	4. A/D converter characteristics	Corrected “Zero reading voltage” and “Full scale reading voltage”.

NOTE: Please see “Document History” about later revised information.

Page	Section	Change Results
Rev. *B		
—	Marketing Part Numbers changed from a prefix MB to a prefix CY.	
—	1. Product Lineup 2. Pin Assignment 3. Pin Description 7. Block Diagram 9. Embedded Program/Data Memory (Flash) 11. Memory Maps 12. I/O Map 14. Recommended Settings 15. Electrical Characteristics	- Added device CY91F466HA - Added Ta=125 °C characteristics - Product Lineup: CY91F464HB has 16KB D-Bus RAM (not 24KB) - Flash memory and external bus area: Changed table formatting for CY91F464HB - IO-Map: Corrected CANCKD register (only bit 0 applicable)
6, 7 102 103	2.Pin Assignment 16.Ordering Information 17.Package Dimension	Package description modified to JEDEC description.
102	16.Ordering Information	Deleted Marketing Part Number as follows: MB91F464HBPMC-GSE2 Added Marketing Part Number as follows: CY91F466HAPMC-GS-UJE2

Document History

Document Title: CY91460H Series FR60 32-bit Microcontroller Document Number: 002-04621				
Revision	ECN	Orig. of Change	Submission Date	Description of Change
**	—	AKIH	08/27/2009	Migrated to Cypress and assigned document number 002-04621. No change to document contents or format.
*A	5221965	AKIH	04/15/2016	Updated to Cypress format.
*B	6459657	SHUS	01/25/2019	<ul style="list-style-type: none"> - Added device CY91F466HA - Added Ta=125 °C characteristics - Product Lineup: CY91F464HB has 16KB D-Bus RAM (not 24KB) - Flash memory and external bus area: Changed table formatting for CY91F464HB - IO-Map: Corrected CANCKD register (only bit 0 applicable) - Package description modified to JEDEC description. - Updated the ordering information For details, please see 19. Major Changes.

Sales, Solutions, and Legal Information

Worldwide Sales and Design Support

Cypress maintains a worldwide network of offices, solution centers, manufacturer's representatives, and distributors. To find the office closest to you, visit us at [Cypress Locations](#).

Products

Arm [®] Cortex [®] Microcontrollers	cypress.com/arm
Automotive	cypress.com/automotive
Clocks & Buffers	cypress.com/clocks
Interface	cypress.com/interface
Internet of Things	cypress.com/iot
Memory	cypress.com/memory
Microcontrollers	cypress.com/mcu
PSoC	cypress.com/psoc
Power Management ICs	cypress.com/pmic
Touch Sensing	cypress.com/touch
USB Controllers	cypress.com/usb
Wireless Connectivity	cypress.com/wireless

PSoC[®] Solutions

[PSoC 1](#) | [PSoC 3](#) | [PSoC 4](#) | [PSoC 5LP](#) | [PSoC 6 MCU](#)

Cypress Developer Community

[Community](#) | [Projects](#) | [Video](#) | [Blogs](#) | [Training](#) | [Components](#)

Technical Support

cypress.com/support

© Cypress Semiconductor Corporation, 2009–2019. This document is the property of Cypress Semiconductor Corporation and its subsidiaries, including Spansion LLC ("Cypress"). This document, including any software or firmware included or referenced in this document ("Software"), is owned by Cypress under the intellectual property laws and treaties of the United States and other countries worldwide. Cypress reserves all rights under such laws and treaties and does not, except as specifically stated in this paragraph, grant any license under its patents, copyrights, trademarks, or other intellectual property rights. If the Software is not accompanied by a license agreement and you do not otherwise have a written agreement with Cypress governing the use of the Software, then Cypress hereby grants you a personal, non-exclusive, nontransferable license (without the right to sublicense) (1) under its copyright rights in the Software (a) for Software provided in source code form, to modify and reproduce the Software solely for use with Cypress hardware products, only internally within your organization, and (b) to distribute the Software in binary code form externally to end users (either directly or indirectly through resellers and distributors), solely for use on Cypress hardware product units, and (2) under those claims of Cypress's patents that are infringed by the Software (as provided by Cypress, unmodified) to make, use, distribute, and import the Software solely for use with Cypress hardware products. Any other use, reproduction, modification, translation, or compilation of the Software is prohibited.

TO THE EXTENT PERMITTED BY APPLICABLE LAW, CYPRESS MAKES NO WARRANTY OF ANY KIND, EXPRESS OR IMPLIED, WITH REGARD TO THIS DOCUMENT OR ANY SOFTWARE OR ACCOMPANYING HARDWARE, INCLUDING, BUT NOT LIMITED TO, THE IMPLIED WARRANTIES OF MERCHANTABILITY AND FITNESS FOR A PARTICULAR PURPOSE. No computing device can be absolutely secure. Therefore, despite security measures implemented in Cypress hardware or software products, Cypress does not assume any liability arising out of any security breach, such as unauthorized access to or use of a Cypress product. In addition, the products described in these materials may contain design defects or errors known as errata which may cause the product to deviate from published specifications. To the extent permitted by applicable law, Cypress reserves the right to make changes to this document without further notice. Cypress does not assume any liability arising out of the application or use of any product or circuit described in this document. Any information provided in this document, including any sample design information or programming code, is provided only for reference purposes. It is the responsibility of the user of this document to properly design, program, and test the functionality and safety of any application made of this information and any resulting product. Cypress products are not designed, intended, or authorized for use as critical components in systems designed or intended for the operation of weapons, weapons systems, nuclear installations, life-support devices or systems, other medical devices or systems (including resuscitation equipment and surgical implants), pollution control or hazardous substances management, or other uses where the failure of the device or system could cause personal injury, death, or property damage ("Unintended Uses"). A critical component is any component of a device or system whose failure to perform can be reasonably expected to cause the failure of the device or system, or to affect its safety or effectiveness. Cypress is not liable, in whole or in part, and you shall and hereby do release Cypress from any claim, damage, or other liability arising from or related to all Unintended Uses of Cypress products. You shall indemnify and hold Cypress harmless from and against all claims, costs, damages, and other liabilities, including claims for personal injury or death, arising from or related to any Unintended Uses of Cypress products.

Cypress, the Cypress logo, Spansion, the Spansion logo, and combinations thereof, WICED, PSoC, CapSense, EZ-USB, F-RAM, and Traveo are trademarks or registered trademarks of Cypress in the United States and other countries. For a more complete list of Cypress trademarks, visit cypress.com. Other names and brands may be claimed as property of their respective owners.