

# USB-UART Automotive single-channel bridge controller

## Features

- USB 2.0-complaint, Full-Speed (12 Mbps)
  - Supports communication driver class (CDC), personal health care device class (PHDC), and vendor-device class
  - Battery charger detection (BCD) compliant with USB Battery Charging Specification, Rev. 1.2 (Peripheral Detect only)
  - Integrated USB termination resistors
- Single-channel configurable UART interface
  - Data rates up to 3 Mbps
  - 190 bytes for each transmit and receive buffer
  - Supports 2-pin, 4-pin, 6-pin, and 8-pin UART interface
  - Data format:
    - 7 to 8 data bits
    - 1 to 2 stop bits
    - No parity, even, odd, mark, or space parity
  - Supports parity, overrun, and framing errors
  - Supports software flow control and flow control using CTS, RTS
  - Supports UART break signal
  - CY7C65223 supports RS232/RS422/RS485 interfaces
- General-purpose input/output (GPIO) pins: 4
- Supports unique serial number feature for each device, which fixes the COM port number permanently when USB-serial Bridge controller as CDC device plugs in
- 512-byte flash for storing configuration parameters
- Configuration utility (Windows) to configure the following:
  - Vendor ID (VID), Product ID (PID), and Product and Manufacturer descriptors
  - UART
  - Charger detection
  - GPIO
- Driver support for VCOM and DLL
  - Windows 10: 32- and 64-bit versions
  - Windows 8.1: 32- and 64-bit versions
  - Windows 8: 32- and 64-bit versions
  - Windows 7: 32- and 64-bit versions
  - Windows Vista: 32- and 64-bit versions
  - Windows XP: 32- and 64-bit versions
  - Windows CE
  - Mac OS-X: 10.6, 10.7
  - Linux: Kernel version 2.6.35 onwards.
- Clocking: Integrated 48-MHz clock oscillator
- Supports bus-/self-powered configurations
- USB Suspend mode for low power
- Operating voltage: 1.71 V to 5.5 V

---

## Applications

- Operating temperature
  - Commercial: 0°C to 70°C
  - Industrial: -40°C to 85°C
  - Automotive: -40°C to 105°C
- ESD protection: 2.2-kV HBM
- RoHS-compliant package
  - 24-pin QFN (4.0 mm × 4.0 mm, 0.55 mm, 0.5 mm pitch)
- Ordering part number
  - CY7C65223-24LTXI
  - CY7C65223-24LTXIT
  - CY7C65223-24LQXS
  - CY7C65223-24LQXST

## Applications

- Automotive
- Medical/healthcare devices
- Point-of-Sale (POS) terminals
- Test and measurement system
- Gaming systems
- Set-top box PC-USB interface
- Industrial
- Networking
- Enabling USB connectivity in legacy peripherals

## Functional description

For a complete list of related resources, click [here](#).

**Note:** The USB-UART Single Channel Bridge Controller is fully compliant with the USB 2.0 Specification and Battery Charging Specification v1.2.

**Errata:** For information on silicon errata, see [Errata](#). Details include trigger conditions, devices affected, and proposed workaround.

Block diagram

**Block diagram**

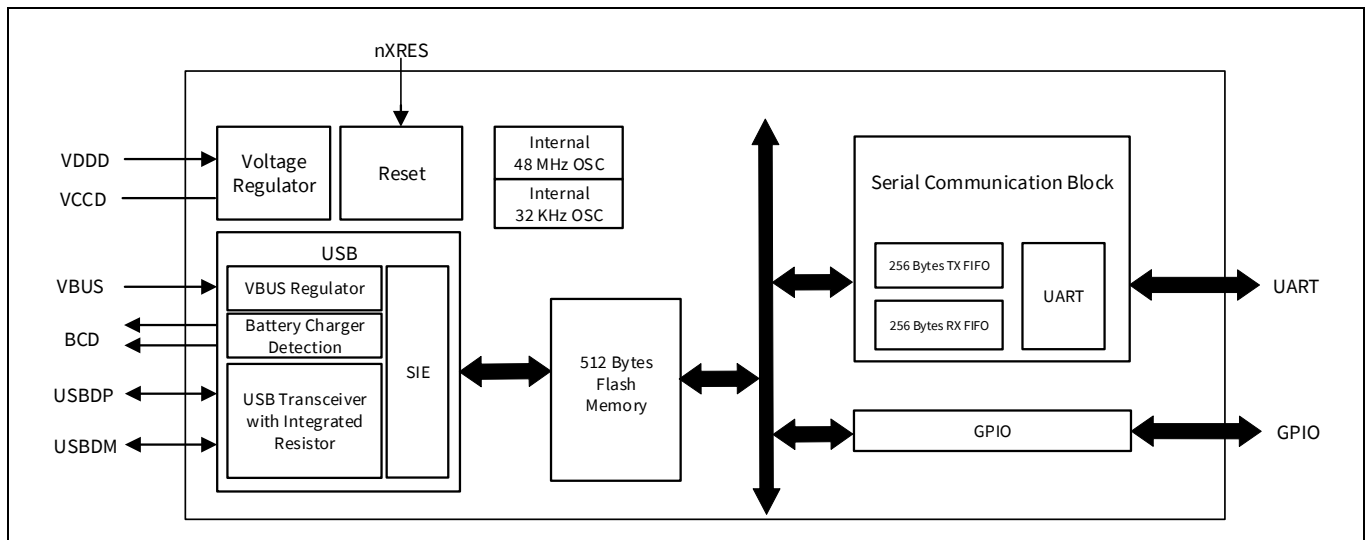

## 1 USB serial bridge controller family

USB Serial bridge Controllers are a family of configurable products for most common applications requiring no firmware changes.

Configuration utility is provided to Configure USB-VID, USB-PID, USB Product and Manufacturer Descriptors. The same configuration utility can be used to configure UART, I<sup>2</sup>C, SPI, Battery Charger Detection, GPIOs, Power mode, and so on.

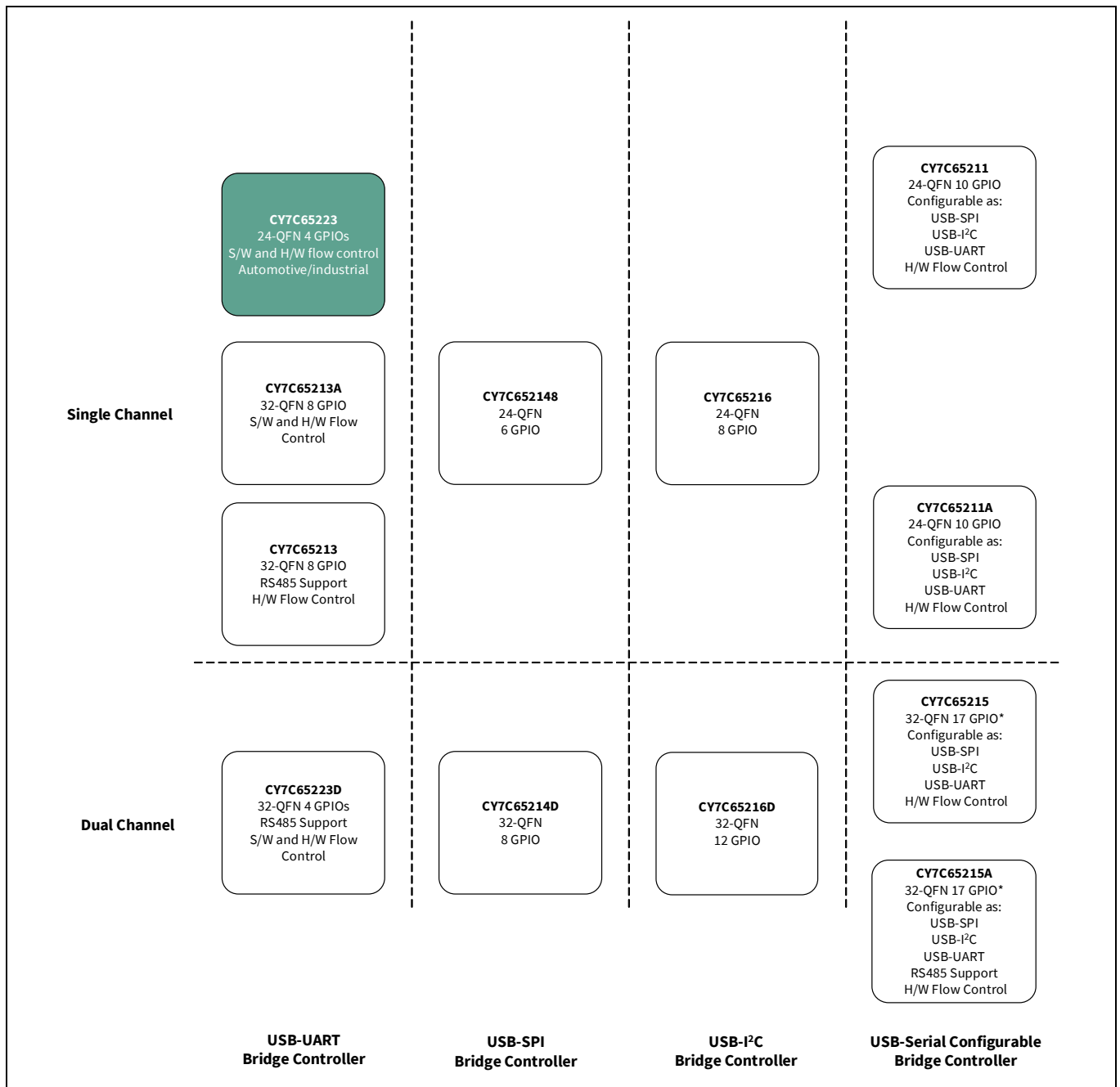

Figure 1 USB serial bridge controller family

**Table 1 USB Serial Family Feature Comparison**

MPN	# of Channels	GPIO	USB-UART				USB-SPI		USB-I <sup>2</sup> C
			RS485 Support	Software Flow Control	Hardware Flow Control	UART Pins**	SPI Serial Data Width (bit)	SPI Master/Slave	I <sup>2</sup> C Master/Slave
CY7C65213	1	8	N	N	Y	8	-	-	-
CY7C65213A	1	8	Y	N	Y	8	-	-	-
CY7C65223	1	4	Y	Y	Y	2 / 4 / 6	-	-	-
CY7C65223D	2	4	Y	Y	Y	2 / 4 / 6 / 8	-	-	-
CY7C652148	1	6	-	-	-	-	4-16 bits	Master/Slave	-
CY7C65214D	2	8	-	-	-	-	4-16 bits	Master/Slave	-
CY7C65216	1	8	-	-	-	-	-	-	Master/Slave
CY7C65216D	2	12	-	-	-	-	-	-	Master/Slave
CY7C65211	1	10*	N	N	Y	2 / 4 / 6	4-16 bits	Master/Slave	Master/Slave
CY7C65211A	1	10*	Y	N	Y	2 / 4 / 6	4-16 bits	Master/Slave	Master/Slave
CY7C65215	2	17*	N	N	Y	2 / 4 / 6	4-16 bits	Master/Slave	Master/Slave
CY7C65215A	2	17*	Y	N	Y	2 / 4 / 6 / 8	4-16 bits	Master/Slave	Master/Slave

**Legend**

\* Represents the total GPIO count offered by the part. This count can dynamically change based on UART / SPI / I<sup>2</sup>C pin configuration.

\*\* UART pins

\*\*\* Hardware flow control is enabled by default when 4/6 UART is configured.

**UART pins	UART signal
2	RxD and TxD
4	RxD, TxD, RTS#, CTS#
6	RxD, TxD, RTS#, CTS#, DTR#, DSR#
8	RxD, TxD, RTS#, CTS#, DTR#, DSR#, DCD#, RI#

**Table 2 Default Serial Channel Configuration**

MPN	# of Channels	GPIO	USB Protocol	USB-UART		USB-SPI	USB-I <sup>2</sup> C
				Is RS485 Enabled	UART pins	SPI Master/Slave	I <sup>2</sup> C Master/Slave
CY7C65213	1	4	CDC**	N	8	-	-
CY7C65213A	1	4	CDC**	N	8	-	-
CY7C65223	1	4	CDC**	Y	4	-	-
CY7C65223D	2	4	CDC**	Y	4	-	-
CY7C652148	1	6	Vendor***	-	-	Master	-
CY7C65214D	2	8	Vendor***	-	-	Master	-
CY7C65216	1	8	Vendor***	-	-	-	Slave
CY7C65216D	2	12	Vendor***	-	-	-	Master
CY7C65211	1	3	CDC**	N	6	-	-
CY7C65211A	1	3	CDC**	N	6	-	-
CY7C65215	2	4	CDC**	N	6	-	-
CY7C65215A	2	4	CDC**	N	6	-	-

\*\* USB CDC Protocol allows the USB host Operating System to detect the device as Virtual COM Port Device.

\*\*\* USB Vendor Protocol allows the USB host operating system to detect the device as general USB device. This device is accessible using Infineon Application Library.

More information

## 2 More information

Infineon provides a wealth of data at [www.infineon.com](http://www.infineon.com) to help you to select the right device for your design, and to help you to quickly and effectively integrate the device into your design. For a comprehensive list of resources, see the document [USB-Serial Bridge Controller Product Overview](#).

- Overview: [USB Portfolio](#)
- USB 2.0 Product Selectors: [USB-Serial Bridge Controller](#)
- Knowledge Base Articles: Cypress offers a large number of USB knowledge base articles covering a broad range of topics, from basic to advanced level. Recommended knowledge base articles for getting started with USB-Serial Bridge Controller are:
  - [KBA85909](#) – Key Features of the Infineon USB-Serial Bridge Controller
  - [KBA85920](#) – USB-UART and USB-Serial
  - [KBA85921](#) – Replacing FT232R with CY7C65213 USB-UART LP Bridge Controller
  - [KBA85913](#) – Voltage supply range for USB-Serial
  - [KBA89355](#) – USB Serial Cypress Default VID and PID
  - [KBA92641](#) – USB-Serial Bridge Controller Managing I/Os using API
  - [KBA92442](#) – Non-Standard Baud Rates in USB-Serial Bridge Controllers
  - [KBA91366](#) – Binding a USB-Serial Device to a Microsoft® CDC Driver
  - [KBA92551](#) – Testing a USB-Serial Bridge Controller Configured as USB-UART with Linux®
  - [KBA91299](#) – Interfacing an External I<sup>2</sup>C Device with the CYUSBS234/236 DVK

For complete list of knowledge base articles, click [here](#).

- Code examples: [USB Full-Speed](#)
- Development Kits:
  - [CYUSBS232](#), USB-UART LP Reference Design Kit
  - [CYUSBS234](#), USB-Serial (Single Channel) Development Kit
  - [CYUSBS236](#), USB-Serial (Dual Channel) Development Kit
- Models: [IBIS](#)

## Table of contents

<b>Features</b> .....	<b>1</b>
<b>Applications</b> .....	<b>2</b>
<b>Functional description</b> .....	<b>2</b>
<b>Block diagram</b> .....	<b>3</b>
<b>1 USB serial bridge controller family</b> .....	<b>4</b>
<b>2 More information</b> .....	<b>7</b>
<b>Table of contents</b> .....	<b>8</b>
<b>3 Functional overview</b> .....	<b>10</b>
3.1 USB and Charger Detect .....	10
3.1.1 USB .....	10
3.1.2 Charger detection .....	10
3.2 Serial communication .....	10
3.2.1 UART interface .....	10
3.2.2 UART flow control .....	10
3.3 GPIO interface .....	11
3.4 Default configuration.....	11
3.5 Memory.....	12
3.6 System resources.....	12
3.6.1 Power system .....	12
3.6.2 Clock system .....	12
3.6.3 Internal 48-MHz oscillator .....	12
3.6.4 Internal 32-kHz oscillator .....	12
3.6.5 Reset.....	12
3.7 Suspend and resume .....	12
3.8 WAKEUP.....	12
3.9 Software .....	13
3.9.1 Drivers for Linux operating systems.....	13
3.9.2 Drivers for Mac OSx.....	13
3.9.3 Drivers for Windows operating systems .....	13
3.9.4 Windows-CE support .....	13
3.10 Internal flash configuration.....	14
<b>4 Electrical specifications</b> .....	<b>15</b>
4.1 Absolute maximum ratings .....	15
4.2 Operating conditions.....	15
4.3 Device-level specifications .....	16
4.4 GPIO .....	17
4.5 nXRES.....	19
4.6 Flash memory specifications.....	19
<b>5 Pin description</b> .....	<b>20</b>
<b>6 USB power configurations</b> .....	<b>23</b>
6.1 USB bus-powered configuration.....	23
6.2 Self-powered configuration .....	24
6.3 USB bus-powered with variable I/O voltage .....	25
<b>7 Application examples</b> .....	<b>26</b>
7.1 USB to RS232 bridge .....	26
7.2 USB to RS485 bridge .....	27
7.3 Battery-operated, bus-powered USB to MCU with Battery Charge Detection .....	28
<b>8 Ordering information</b> .....	<b>31</b>
8.1 Ordering code definitions.....	31
<b>9 Package information</b> .....	<b>32</b>



---

Table of contents

<b>10 Acronyms .....</b>	<b>33</b>
<b>11 Document conventions.....</b>	<b>34</b>
11.1 Units of measure .....	34
<b>12 Errata .....</b>	<b>35</b>
<b>Revision history .....</b>	<b>36</b>

### 3 Functional overview

The CY7C65223 is a Full-Speed USB controller that enables seamless PC connectivity for peripherals with UART interface. CY7C65223 also integrates BCD functionality compliant with the USB Battery Charging Specification, Rev. 1.2. It integrates a voltage regulator, an oscillator, and flash memory for storing configuration parameters, offering a cost-effective solution. CY7C65223 supports bus-powered and self-powered modes and enables efficient system power management with suspend and remote wake-up signals. It is available in a 24-pin QFN package.

#### 3.1 USB and Charger Detect

##### 3.1.1 USB

CY7C65223 has a built-in USB 2.0 Full-Speed transceiver. The transceiver incorporates the internal USB series termination resistors on the USB data lines and a 1.5-k $\Omega$  pull-up resistor on USBDP.

##### 3.1.2 Charger detection

CY7C65223 supports BCD for Peripheral Detect only and complies with the USB Battery Charging Specification, Rev. 1.2. It supports the following charging ports:

- Standard Downstream Port (SDP): Allows the system to draw up to 500 mA current from the host
- Charging Downstream Port (CDP): Allows the system to draw up to 1.5 A current from the host
- Dedicated Charging Port (DCP): Allows the system to draw up to 1.5 A of current from the wall charger

#### 3.2 Serial communication

CY7C65223 has a serial communication block (SCB). Each SCB can implement UART interface. A 256-byte buffer is available in both the TX and RX lines.

##### 3.2.1 UART interface

The UART interface provides asynchronous serial communication with other UART devices operating at speeds of up to 3 Mbps. It supports 7 to 8 data bits, 1 to 2 stop bits, odd, even, mark, space, and no parity. The UART interface supports full-duplex communication with a signaling format that is compatible with the standard UART protocol. In CY7C65223 UART pins may be interfaced to RS232/RS422/RS485 drivers.

Common UART functions, such as parity error and frame error, are supported. CY7C65223 supports baud rates ranging from 300 baud to 3 Mbaud. The UART baud rates can be set using the configuration utility.

##### Notes

- Parity error gets detected when UART transmitter device is configured for odd parity and UART receiver device is configured for even parity.
- Frame error gets detected when UART transmitter device is configured for 7 bits data width and 1 stop bit, whereas UART receiver device is configured for 8 bit data width and 2 stop bits.

##### 3.2.2 UART flow control

UART Data Flow control is the process of signaling the UART partner device to WAIT or RESUME the data transmission. This flow control process is required for the slower device to catch up with the partner device without data loss. The CY7C65223 device supports both UART hardware and software flow control.

By default, flow control is disabled. USB host UART terminal applications can enable or disable either hardware or software flow control through operating system software interfaces. CYUSB223T has hardware flow control enabled by default when 4/6 UART is configured.

Hardware flow control uses signal pairs such as RTS# (Request to Send) / CTS# (Clear to Send) to control the data flow between partner UART devices.

Software flow control do not use additional hardware signaling pairs. But, software flow control uses in-band communication using special characters called XON or XOFF. These XON or XOFF characters are exchanged at UART PHY level for data flow control. These XON or XOFF characters doesn't reflect in the actual data received by the USB host application.

---

## Functional overview

The following section describes the flow control signals:

- CTS# (Input) / RTS# (Output)

CTS# can pause or resume data transmission over the UART interface. Data transmission can be paused by de-asserting the CTS signal and resumed with CTS# assertion. The pause and resume operation does not affect data integrity. With flow control enabled, receive buffer has a watermark level of 93%. After the data in the receive buffer reaches that level, the RTS# signal is de-asserted, instructing the transmitting device to stop data transmission. The start of data consumption by application reduces the device data backlog; when it reaches the 75% watermark level, the RTS# signal is asserted to resume data reception.

- DSR# (Input) /DTR# (Output)

The DSR#/DTR# signals are used to establish a communication link with the UART. These signals complement each other in their functionality, similar to CTS# and RTS#.

### 3.3 GPIO interface

CY7C65223 has 4 GPIOs. The maximum available GPIOs for configuration is 10 if one two-pin UART serial interface is implemented. The configuration utility allows configuration of the GPIO pins. The configurable options are as follows:

- TRISTATE: GPIO can be tristated through Config Utility
- DRIVE 1: Output static 1
- DRIVE 0: Output static 0
- POWER#: Power control for bus power designs
- TXLED#: Drives LED during USB transmit
- RXLED#: Drives LED during USB receive
- TX or RX LED#: Drives LED during USB transmit or receive GPIO can be configured to drive LED at 8-mA drive strength.
- BCD0/BCD1: Two-pin output to indicate the type of USB charger
- BUSDETECT: Connects the VBUS pin for USB host detection

### 3.4 Default configuration

CY7C65223 is configured as single-channel 4-pin UART.

## 3.5 Memory

CY7C65223 has a 512-byte flash. Flash is used to store USB parameters, such as VID/PID, serial number, product and manufacturer descriptors, which can be programmed by the configuration utility.

## 3.6 System resources

### 3.6.1 Power system

CY7C65223 supports the USB Suspend mode to control power usage. CY7C65223 operates in bus-powered or self-powered modes over a range of 3.15 to 5.5 V.

### 3.6.2 Clock system

CY7C65223 has a fully integrated clock with no external components required. The clock system is responsible for providing clocks to all subsystems.

### 3.6.3 Internal 48-MHz oscillator

The internal 48-MHz oscillator is the primary source of internal clocking in CY7C65223.

### 3.6.4 Internal 32-kHz oscillator

The internal 32-kHz oscillator is primarily used to generate clocks for peripheral operation in the USB Suspend mode.

### 3.6.5 Reset

The reset block ensures reliable power-on reset and brings the device back to the default known state. The nXRES (active low) pin can be used by the external devices to reset the CY7C65223.

## 3.7 Suspend and resume

The CY7C65223 device asserts the SUSPEND pin when the USB bus enters the suspend state. This helps in meeting the stringent suspend current requirement of the USB 2.0 specification, while using the device in bus-powered mode. The device resumes from the suspend state under either of the two following conditions:

1. Any activity is detected on the USB bus
2. The WAKEUP pin is asserted to generate remote wakeup to the host

## 3.8 WAKEUP

The WAKEUP pin is used to generate the remote wakeup signal on the USB bus. The remote wakeup signal is sent only if the host enables this feature through the SET\_FEATURE request. The device communicates support for the remote wakeup to the host through the configuration descriptor during the USB enumeration process. The CY7C65223 device allows enabling/disabling and polarity of the remote wakeup feature through the configuration utility.

## 3.9 Software

Infineon delivers a complete set of software drivers and a configuration utility to enable configuration of the product during system development.

### 3.9.1 Drivers for Linux operating systems

Infineon provides a User Mode USB driver library (*libcyusbserial.so*) that abstracts vendor commands for the UART interface and provides a simplified API interface for user applications. This library uses the standard open-source libUSB library to enable USB communication. The Infineon serial library supports the USB plug-and-play feature using the Linux ‘udev’ mechanism.

CY7C65223 supports the standard USB CDC UART class driver, which is bundled with the Linux kernel.

### 3.9.2 Drivers for Mac OSx

Infineon delivers a dynamically linked shared library (*CyUSBSerial.dylib*) based on libUSB, which enables communication to the CY7C65223 device.

In addition, CY7C65223 supports native Mac OSx CDC UART driver.

### 3.9.3 Drivers for Windows operating systems

For Windows operating systems (XP, Vista, Win7, Win 8, and Win 8.1), Infineon delivers a user-mode dynamically linked library–CyUSBSerial DLL–that abstracts a vendor-specific interface of the CY7C65223 devices and provides convenient APIs to the user. It provides interface APIs for vendor-specific UART and class-specific APIs for PHDC.

USB-Serial Bridge Controller works with the Windows-standard USB CDC class driver, when CY7C65223 is configured as CDC USB to UART device. A virtual COM port driver–CyUSBSerial.sys–is also delivered, which implements the USB CDC class driver. The Infineon Windows drivers are Windows hardware certification kit-compliant.

These drivers are bound to device through WU (Windows Update) services.

Infineon drivers also support Windows plug-and-play and power management and USB Remote Wake-up.

### 3.9.4 Windows-CE support

The CY7C65223 solution includes a CDC UART driver library for Windows-CE platforms.

#### Device Configuration Utility (Windows only)

A Windows-based configuration utility is available to configure device initialization parameters. This graphical user application provides an interactive interface to define the boot parameters stored in the device flash.

This utility allows the user to save a user-selected configuration to text or xml formats. It also allows users to load a selected configuration from text or xml formats. The configuration utility allows the following operations:

- View current device configuration
- Select and configure UART, battery charging, and GPIOs
- Configure USB VID, PID, and string descriptors
- Save or Load configuration

You can download the free configuration utility and drivers at [www.infineon.com](http://www.infineon.com).

## 3.10 Internal flash configuration

The internal flash memory can be used to store the configuration parameters shown in **Table 3**. A free configuration utility is provided to configure the parameters listed in the table to meet application-specific requirements over the USB interface. The configuration utility can be downloaded at [www.infineon.com/usbserial](http://www.infineon.com/usbserial).

**Table 3 Internal flash configuration for CY7C65223**

Parameter	Default value	Description
<b>USB Configuration</b>		
USB Vendor ID (VID)	0x04B4	Default Infineon VID. Can be configured to customer VID.
USB Product ID (PID)	0x00FB	Default Infineon PID. Can be configured to customer PID.
Manufacturer string	Cypress	Can be configured with any string up-to 64 characters.
Product string	USB-Serial (Single Channel)	Can be configured with any string up-to 64 characters.
Serial string		Can be configured with any string up-to 64 characters.
Power mode	Bus powered	Can be configured to bus-powered or self-powered mode.
Max current draw	100 mA	Can be configured to any value from 0 to 500 mA. The configuration descriptor will be updated based on this.
Remote wakeup	Enabled	Can be disabled. Remote wakeup is initiated by asserting the WAKEUP pin.
USB interface protocol	CDC	Can be configured to function in CDC, PHDC, or Infineon vendor class.
BCD	Disabled	Charger detect is disabled by default. When BCD is enabled, three of the GPIOs must be configured for BCD.

## 4 Electrical specifications

### 4.1 Absolute maximum ratings

Exceeding maximum ratings<sup>[1]</sup> may shorten the useful life of the device.

**Table 4 Absolute maximum ratings**

Parameter	Max ratings
Storage temperature (Industrial, commercial)	-55°C to +100°C
Storage temperature (Automotive)	-55°C to +150°C
Ambient temperature with power supplied (Industrial, commercial)	-40°C to +85°C
Ambient temperature with power supplied (Automotive)	-40°C to +105°C
Supply voltage to ground potential	
$V_{DDD}$	6.0 V
$V_{BUS}$	6.0 V
$V_{CCD}$	1.95 V
$V_{GPIO}$	$V_{DDD} + 0.5 V$
Static discharge voltage ESD protection levels: 2.2-kV HBM per JESD22-A114	
Latch-up current	140 mA
Current per GPIO	25 mA

### 4.2 Operating conditions

**Table 5 Operating conditions**

Parameter	Values
$T_A$ (ambient temperature under bias)	
Industrial	-40°C to +85°C
Automotive	-40°C to +105°C
$V_{BUS}$ supply voltage	3.15 V to 5.25 V
$V_{DDD}$ supply voltage	1.71 V to 5.50 V
$V_{CCD}$ supply voltage	1.71 V to 1.89 V

#### Note

- Usage above the Absolute Maximum conditions may cause permanent damage to the device. Exposure to Absolute Maximum conditions for extended periods of time may affect device reliability. When used below Absolute Maximum conditions but above normal operating conditions, the device may not operate to specification.

## Electrical specifications

**4.3 Device-level specifications**

 All specifications are valid for  $-40^{\circ}\text{C} \leq T_A \leq 105^{\circ}\text{C}$ ,  $T_J \leq 120^{\circ}\text{C}$ , and 1.71 V to 5.50 V, except where noted.

**Table 6 DC specifications**

Parameter	Description	Min	Typ	Max	Units	Details/conditions
$V_{\text{BUS}}$	$V_{\text{BUS}}$ supply voltage	3.15	3.30	3.45	V	Set and configure the correct voltage range using a configuration utility for $V_{\text{BUS}}$ . Default 5 V.
		4.35	5.00	5.25	V	
$V_{\text{DDD}}$	$V_{\text{DDD}}$ supply voltage	1.71	1.80	1.89	V	Used to set I/O and core voltage. Set and configure the correct voltage range using a configuration utility for $V_{\text{DDD}}$ . Default 3.3 V.
		2.0	3.3	5.5	V	
$V_{\text{CCD}}$	Output voltage (for core logic)	–	1.80	–	V	Do not use this supply to drive the external device. <ul style="list-style-type: none"> <li><math>1.71\text{ V} \leq V_{\text{DDD}} \leq 1.89\text{ V}</math>: Short the <math>V_{\text{CCD}}</math> pin with the <math>V_{\text{DDD}}</math> pin.</li> <li><math>V_{\text{DDD}} &gt; 2\text{ V}</math> – connect a 1-<math>\mu\text{F}</math> capacitor (Cefc) between the <math>V_{\text{CCD}}</math> pin and ground.</li> </ul>
Cefc	External regulator voltage bypass	1.00	1.30	1.60	$\mu\text{F}$	X5R ceramic or better
$I_{\text{DD1}}$	Operating supply current	–	20	–	mA	USB 2.0 FS, UART at 1-Mbps single channel, no GPIO switching.
$I_{\text{DD2}}$	USB Suspend supply current	–	5	–	$\mu\text{A}$	Does not include current through a pull-up resistor on USBDP. In USB suspend mode, the D+ voltage can go up to a maximum of 3.8 V.

**Table 7 AC specifications**

Parameter	Description	Min	Typ	Max	Units	Details/conditions
Zout	USB driver output impedance	28	–	44	$\Omega$	–
Twakeup	Wakeup from USB Suspend mode	–	25	–	$\mu\text{s}$	–



## Electrical specifications

**4.4 GPIO**
**Table 8 GPIO DC specifications**

Parameter	Description	Min	Typ	Max	Units	Details/conditions
$V_{IH}^{[2]}$	Input voltage high threshold	$0.7 \times V_{DDD}$	-	-	V	CMOS Input
$V_{IL}$	Input voltage low threshold	-	-	$0.3 \times V_{DDD}$	V	CMOS Input
$V_{IH}^{[2]}$	LVTTL input, $V_{DDD} < 2.7\text{ V}$	$0.7 \times V_{DDD}$	-	-	V	-
$V_{IL}$	LVTTL input, $V_{DDD} < 2.7\text{ V}$	-	-	$0.3 \times V_{DDD}$	V	-
$V_{IH}^{[2]}$	LVTTL input, $V_{DDD} \geq 2.7\text{ V}$	2	-	-	V	-
$V_{IL}$	LVTTL input, $V_{DDD} \geq 2.7\text{ V}$	-	-	0.8	V	-
$V_{OH}$	CMOS output voltage high level	$V_{DDD} - 0.4$	-	-	V	$I_{OH} = 4\text{ mA}$ , $V_{DDD} = 5\text{ V} \pm 10\%$
$V_{OH}$	CMOS output voltage high level	$V_{DDD} - 0.6$	-	-	V	$I_{OH} = 4\text{ mA}$ , $V_{DDD} = 3.3\text{ V} \pm 10\%$
$V_{OH}$	CMOS output voltage high level	$V_{DDD} - 0.5$	-	-	V	$I_{OH} = 1\text{ mA}$ , $V_{DDD} = 1.8\text{ V} \pm 5\%$
$V_{OL}$	CMOS output voltage low level	-	-	0.4	V	$I_{OL} = 8\text{ mA}$ , $V_{DDD} = 5\text{ V} \pm 10\%$
$V_{OL}$	CMOS output voltage low level	-	-	0.6	V	$I_{OL} = 8\text{ mA}$ , $V_{DDD} = 3.3\text{ V} \pm 10\%$
$V_{OL}$	CMOS output voltage low level	-	-	0.6	V	$I_{OL} = 4\text{ mA}$ , $V_{DDD} = 1.8\text{ V} \pm 5\%$
Rpullup	Pull-up resistor	3.5	5.6	8.5	k $\Omega$	-
Rpulldown	Pull-down resistor	3.5	5.6	8.5	k $\Omega$	-
$I_{IL}$	Input leakage current (absolute value)	-	-	2	nA	25°C, $V_{DDD} = 3.0\text{ V}$
$C_{IN}$	Input capacitance	-	-	7	pF	-
Vhysttl	Input hysteresis LVTTL; $V_{DDD} > 2.7\text{ V}$	25	40	C	mV	-
Vhyscmos	Input hysteresis CMOS	$0.05 \times V_{DDD}$	-	-	mV	-

**Note**

 2.  $V_{IH}$  must not exceed  $V_{DDD} + 0.2\text{ V}$ .

## Electrical specifications

**Table 9** GPIO AC specifications

Parameter	Description	Min	Typ	Max	Units	Details/conditions
$T_{\text{RiseFast1}}$	Rise Time in Fast mode	2	-	12	ns	$V_{\text{DDD}} = 3.3 \text{ V} / 5.5 \text{ V}$ , Load = 25 pF
$T_{\text{FallFast1}}$	Fall Time in Fast mode	2	-	12	ns	$V_{\text{DDD}} = 3.3 \text{ V} / 5.5 \text{ V}$ , Load = 25 pF
$T_{\text{RiseSlow1}}$	Rise Time in Slow mode	10	-	60	ns	$V_{\text{DDD}} = 3.3 \text{ V} / 5.5 \text{ V}$ , Load = 25 pF
$T_{\text{FallSlow1}}$	Fall Time in Slow mode	10	-	60	ns	$V_{\text{DDD}} = 3.3 \text{ V} / 5.5 \text{ V}$ , Load = 25 pF
$T_{\text{RiseFast2}}$	Rise Time in Fast mode	2	-	20	ns	$V_{\text{DDD}} = 1.8 \text{ V}$ , Load = 25 pF
$T_{\text{FallFast2}}$	Fall Time in Fast mode	20	-	100	ns	$V_{\text{DDD}} = 1.8 \text{ V}$ , Load = 25 pF
$T_{\text{RiseSlow2}}$	Rise Time in Slow mode	2	-	20	ns	$V_{\text{DDD}} = 1.8 \text{ V}$ , Load = 25 pF
$T_{\text{FallSlow2}}$	Fall Time in Slow mode	20	-	100	ns	$V_{\text{DDD}} = 1.8 \text{ V}$ , Load = 25 pF

## Electrical specifications

### 4.5 nXRES

**Table 10 nXRES DC specifications**

Parameter	Description	Min	Typ	Max	Units	Details/conditions
$V_{IH}$	Input voltage high threshold	$0.7 \times V_{DDD}$	–	–	V	–
$V_{IL}$	Input voltage low threshold	–	–	$0.3 \times V_{DDD}$	V	–
Rpullup	Pull-up resistor	3.5	5.6	8.5	k $\Omega$	–
$C_{IN}$	Input capacitance	–	5	–	pF	–
Vhysxres	Input voltage hysteresis	–	100	–	mV	–

**Table 11 nXRES AC specifications**

Parameter	Description	Min	Typ	Max	Units	Details/conditions
Tresetwidth	Reset pulse width	1	–	–	$\mu$ s	–

**Table 12 UART AC specifications**

Parameter	Description	Min	Typ	Max	Units	Details/conditions
$F_{UART}$	UART bit rate	0.3	–	3000	kbps	–

### 4.6 Flash memory specifications

**Table 13 Flash memory specifications**

Parameter	Description	Min	Typ	Max	Units	Details/conditions
Fend	Flash endurance	100K	–	–	cycles	–
Fret	Flash retention. $T_A \leq 85^\circ\text{C}$ , 10 K program/erase cycles	10	–	–	years	–

Pin description

## 5 Pin description

**Table 14 Pin description**

Pin <sup>[3]</sup>	Type	Name	Default	Description
1	SCB/GPIO	RxD		UART Receive Pin
2	SCB/GPIO	GPIO_7	GPIO IN	GPIO Input Pin (see <a href="#">Table 16</a> )
3	Power	VSSD		Digital Ground
4	GPIO	Tx_EN		UART RS485 Transmit Enable
5	GPIO	GPIO_9	GPIO IN	GPIO Input Pin (see <a href="#">Table 16</a> )
6	GPIO	GPIO_10	GPIO OUT	GPIO Output Pin (see <a href="#">Table 16</a> )
7	Output	POWER#		Signal to external logic to indicate USB Unconfigured state and USB Suspend
8	Output	Suspend		Indicates device in suspend mode. Can be configured as active low/high using the configuration utility.
9	Input	Wakeup		Wakeup device from suspend mode. Can be configured as active low/high using the configuration utility.
10	USBIO	USBDP		USB Data Signal Plus, integrates termination resistor and a 1.5-kΩ pull-up resistor
11	USBIO	USBDM		USB Data Signal Minus, integrates termination resistor
12	Power	VCCD		This pin should be decoupled to ground using a 1-μF capacitor or by connecting a 1.8-V supply (Internal LDO Output).
13	Power	VSSD		Digital Ground
14	Reset	nXRES		Chip Reset active, low. Can be left unconnected or have a pull up resistor connected when not in use.
15	Power	VBUS		VBUS Supply, 3.15 V to 5.25 V
16	Power	VSSD (VBUS)		Digital Ground
17	Power	VSSA		Analog Ground
18	GPIO	TXLED_0		Notification LED for SCB0 UART Tx
19	GPIO	RXLED_0		Notification LED for SCB0 UART Rx
20	SCB/GPIO	GPIO_2	GPIO OUT	GPIO Output Pin (see <a href="#">Table 16</a> )
21	SCB/GPIO	RTS		SCB0 UART Hardware Flow Control
22	SCB/GPIO	CTS#		SCB0 UART Hardware Flow Control
23	SCB/GPIO	TxD		SCB0 UART Tx
24	Power	VDDD		VDDD Core

**Note**

3. Any pin acting as an Input pin should not be left unconnected.

## Pin description

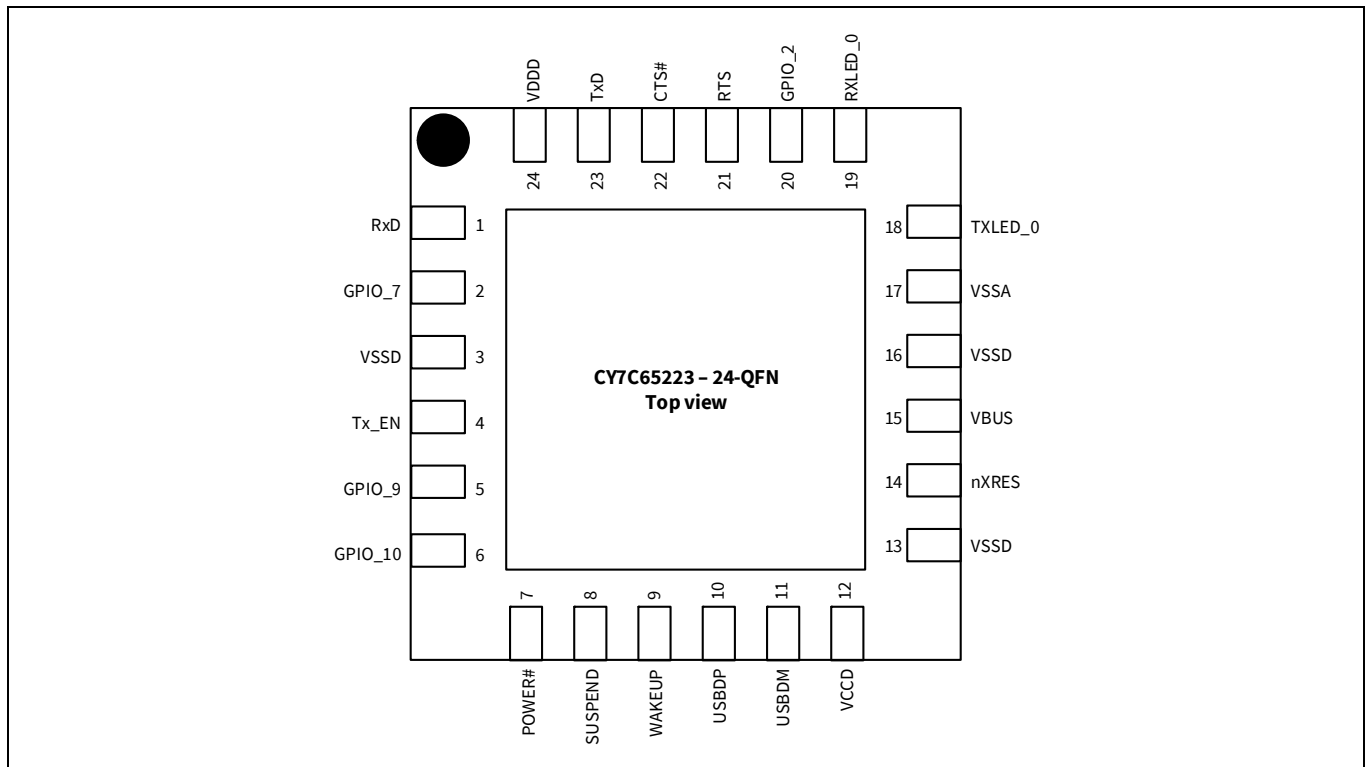

**Figure 2** 24-pin QFN pinout

**Table 15** Serial Communication Block Configuration

Pin	Serial Port	Mode 0 <sup>[4]</sup>	Mode 1	Mode 2
		6-pin UART	4-pin UART	2-pin UART
1	SCB_0	RxD	RxD	RxD
20	SCB_1	DSR#	GPIO_2	GPIO_2
21	SCB_2	RTS#	RTS#	GPIO_3
22	SCB_3	CTS#	CTS#	GPIO_4
23	SCB_4	TxD	TxD	TxD
2	SCB_5	DTR#	GPIO_7	GPIO_7

### Legend

	GPIO
	SCB

### Note

4. The device is configured in Mode 0 as the default. Other modes can be configured using the configuration utility provided by Infineon.

Pin description

**Table 16** GPIO Configuration<sup>[5]</sup>

GPIO Configuration option	Description
TRISTATE	I/O tristated
DRIVE 1	Output static 1
DRIVE 0	Output static 0
POWER#	This output is used to control power to an external logic through a switch to cut power off during an unconfigured USB device and USB suspend. 0 - USB device in Configured state 1 - USB device in Unconfigured state or during USB suspend mode
TXLED#	Drives LED during USB transmit
RXLED#	Drives LED during USB receive
TX or RX LED#	Drives LED during USB transmit or receive
BCD0 BCD1	Configurable battery charger detect pins to indicate the type of USB charger (SDP, CDP, or DCP) Configuration example: 00 - Draw up to 100 mA (unconfigured state) 01 - SDP (up to 500 mA) 10 - CDP/DCP (up to 1.5 A) 11 - Suspend (up to 2.5 mA) This truth table can be configured using a configuration utility
BUSDETECT	VBUS detection. Connect the VBUS to this pin through a resistor network for VBUS detection when using the BCD feature (refer to <a href="#">Figure 10</a> , <a href="#">Figure 11</a> , and <a href="#">Figure 12</a> ).

**Note**

5. These signal options can be configured on any of the available GPIO pins using the configuration utility provided by Infineon.

## 6 USB power configurations

The following section describes possible USB power configurations for the CY7C65223. Refer to the “[Pin description](#)” on page 20 for signal details.

### 6.1 USB bus-powered configuration

**Figure 3** shows an example of the CY7C65223 in a bus-powered design. The VBUS is connected directly to the CY7C65223 because it has an internal regulator.

The USB bus-powered system must comply with the following requirements:

1. The system should not draw more than 100 mA prior to USB enumeration (Unconfigured state).
2. The system should not draw more than 2.5 mA during the USB Suspend mode.
3. A high-power bus-powered system (can draw more than 100 mA when operational) must use POWER# (configured over GPIO) to keep the current consumption below 100 mA prior to USB enumeration, and 2.5 mA during USB Suspend state.
4. The system should not draw more than 500 mA from the USB host.

The configuration descriptor in the CY7C65223 flash should be updated to indicate bus power and the maximum current required by the system using the configuration utility.

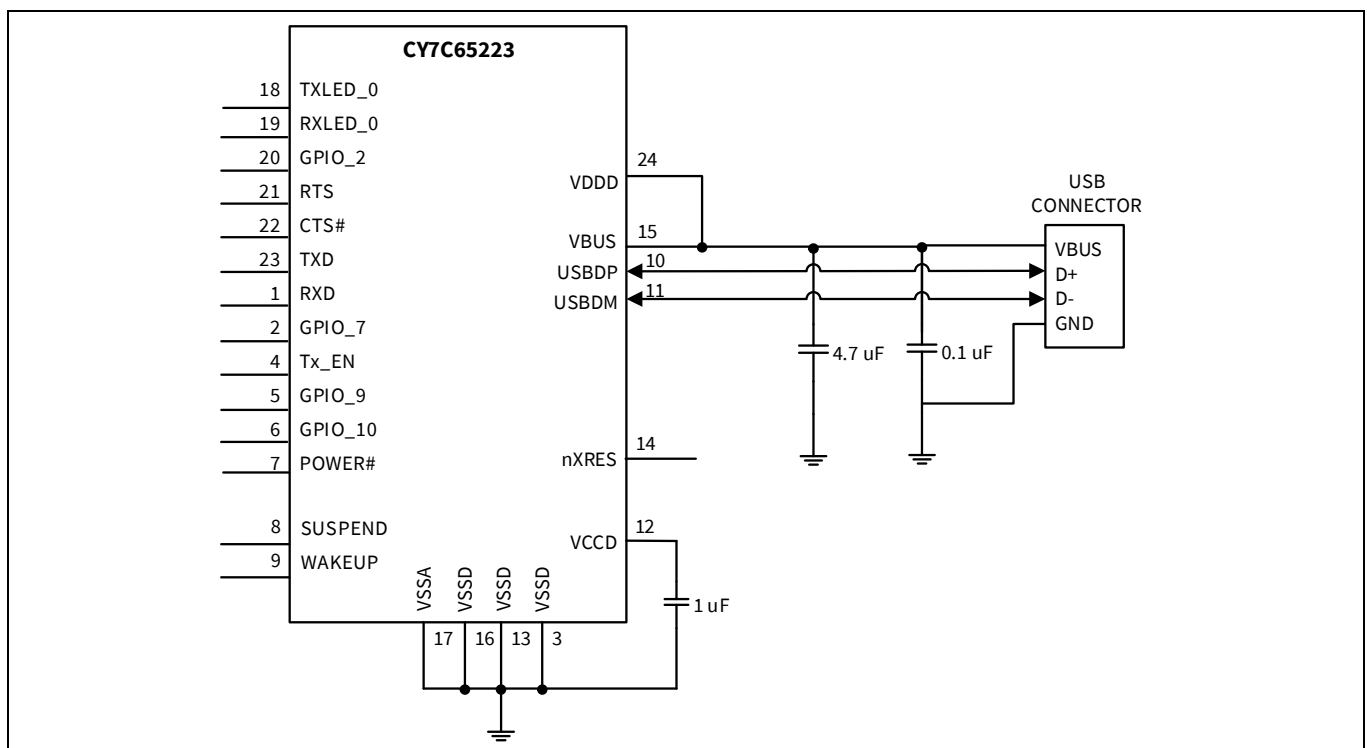

**Figure 3 Bus-powered configuration**

### 6.2 Self-powered configuration

**Figure 4** shows an example of CY7C65223 in a self-powered design. A self-powered system does not use the VBUS from the host to power the system, but it has its own power supply. A self-powered system has no restriction on current consumption because it does not draw any current from the VBUS.

When the VBUS is present, CY7C65223 enables an internal, 1.5-k $\Omega$  pull-up resistor on USBDP. When the VBUS is absent (USB host is powered down), CY7C65223 removes the 1.5-k $\Omega$  pull-up resistor on USBDP. This ensures that no current flows from the USBDP to the USB host through a 1.5-k $\Omega$  pull-up resistor, to comply with the USB 2.0 specification.

When reset is asserted to CY7C65223, all the I/O pins are tristated.

The configuration descriptor in the CY7C65223 flash should be updated to indicate self-power using the configuration utility.

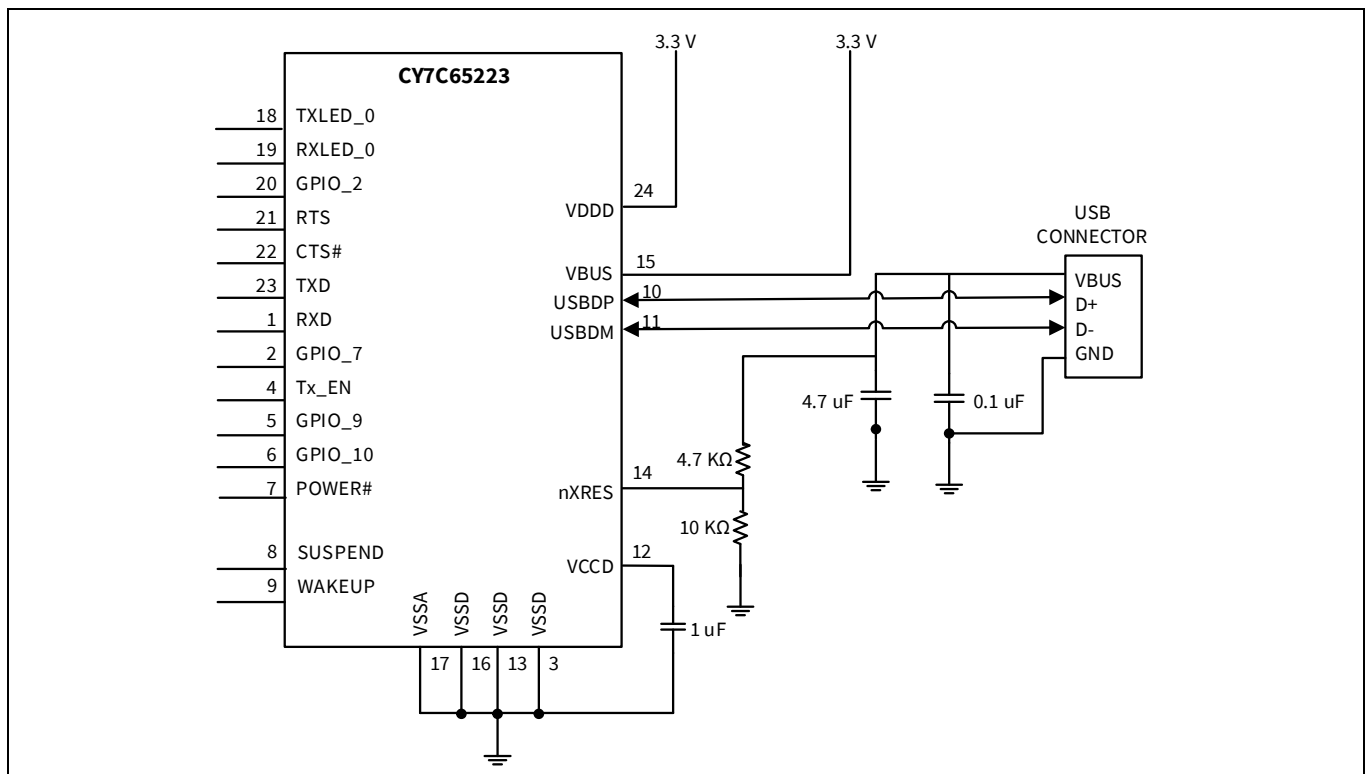

**Figure 4** Self-powered configuration



### 6.3 USB bus-powered with variable I/O voltage

**Figure 5** shows CY7C65223 in a bus-powered system with variable I/O voltage. A low dropout (LDO) regulator is used to supply 1.8 V or 3.3 V, using a jumper switch the input of which is 5 V from the VBUS. Another jumper switch is used to select 1.8/3.3 V or 5 V from the VBUS for the VDDD pin of CY7C65223. This allows I/O voltage and supply to external logic to be selected among 1.8 V, 3.3 V, or 5 V.

The USB bus-powered system must comply with the following conditions:

- The system should not draw more than 100 mA prior to USB enumeration (unconfigured state).
- The system should not draw more than 2.5 mA during USB Suspend mode.
- A high-power bus-powered system (can draw more than 100 mA when operational) must use POWER# (configured over GPIO) to keep the current consumption below 100 mA prior to USB enumeration and 2.5 mA during the USB Suspend state.

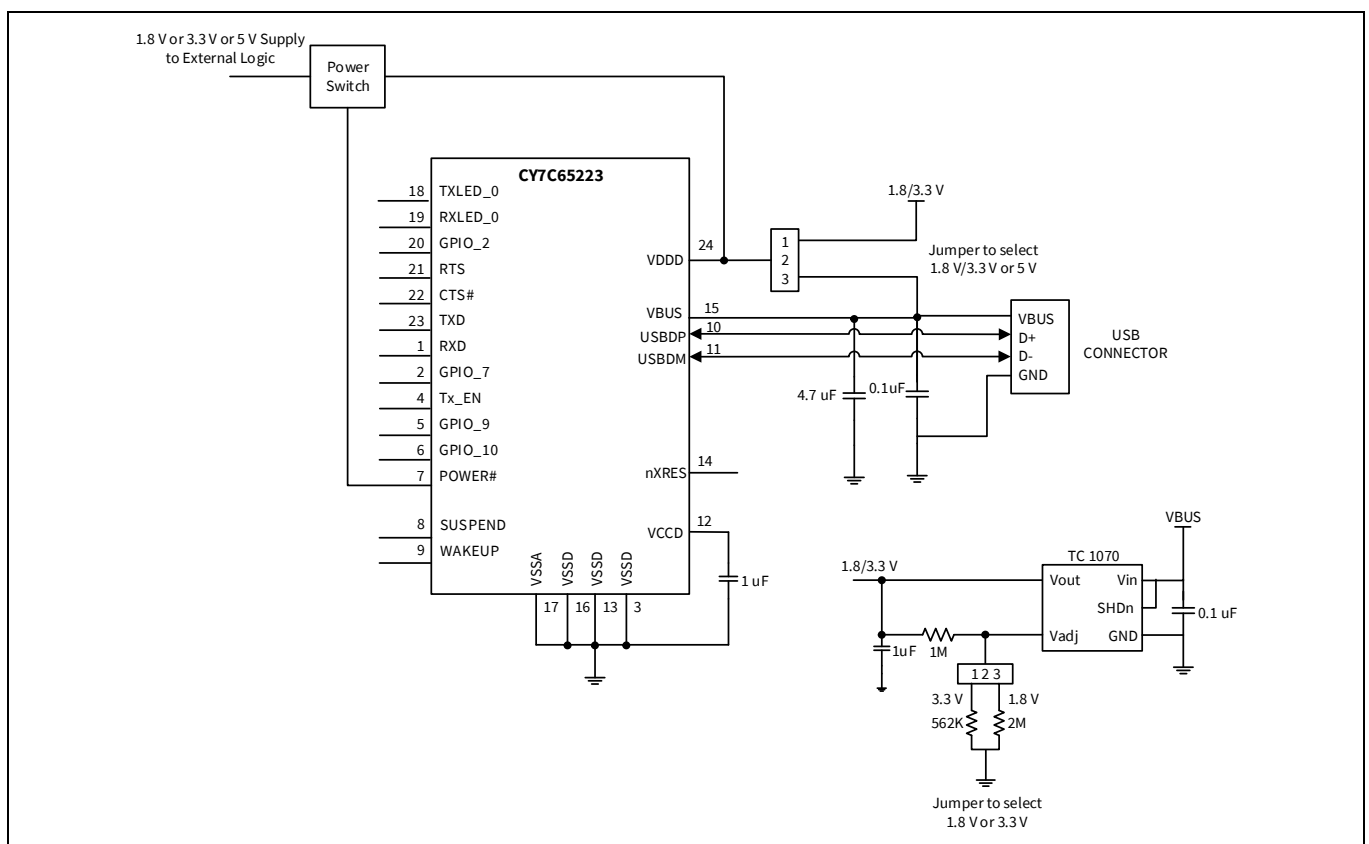

**Figure 5** USB bus-powered with 1.8-V, 3.3-V, or 5-V variable I/O voltage [6]

#### Note

1.  $1.71\text{ V} \leq \text{VDDD} \leq 1.89\text{ V}$  - Short VCCD pin with VDDD pin;  $\text{VDDD} > 2\text{ V}$  - connect a 1- $\mu\text{F}$  decoupling capacitor to the VCCD pin.

## 7 Application examples

The following section provides CY7C65223 application examples.

### 7.1 USB to RS232 bridge

CY7C65223 can connect any embedded system, with a serial port, to a host PC through USB. CY7C65223 enumerates as a COM port on the host PC.

The RS232 protocol follows bipolar signaling – that is, the output signal toggles between negative and positive polarity. The valid RS232 signal is either in the  $-3\text{V}$  to  $-15\text{V}$  range or in the  $+3\text{V}$  to  $+15\text{V}$  range, and the range between  $-3\text{V}$  to  $+3\text{V}$  is invalid. In the RS232, Logic 1 is called “Mark” and it corresponds to a negative voltage range. Logic 0 is called “Space” and it corresponds to a positive voltage range. The RS232 level converter facilitates this polarity inversion and the voltage-level translation between the CY7C65223’s UART interface and RS232 signaling.

In this application, as shown in **Figure 6**, SUSPEND is connected to the SHDN# pin of the RS232-level converter to indicate USB suspend or USB not enumerated.

GPIO8 and GPIO9 are configured as RXLED# and TXLED# to drive two LEDs, indicating data transmit and receive.

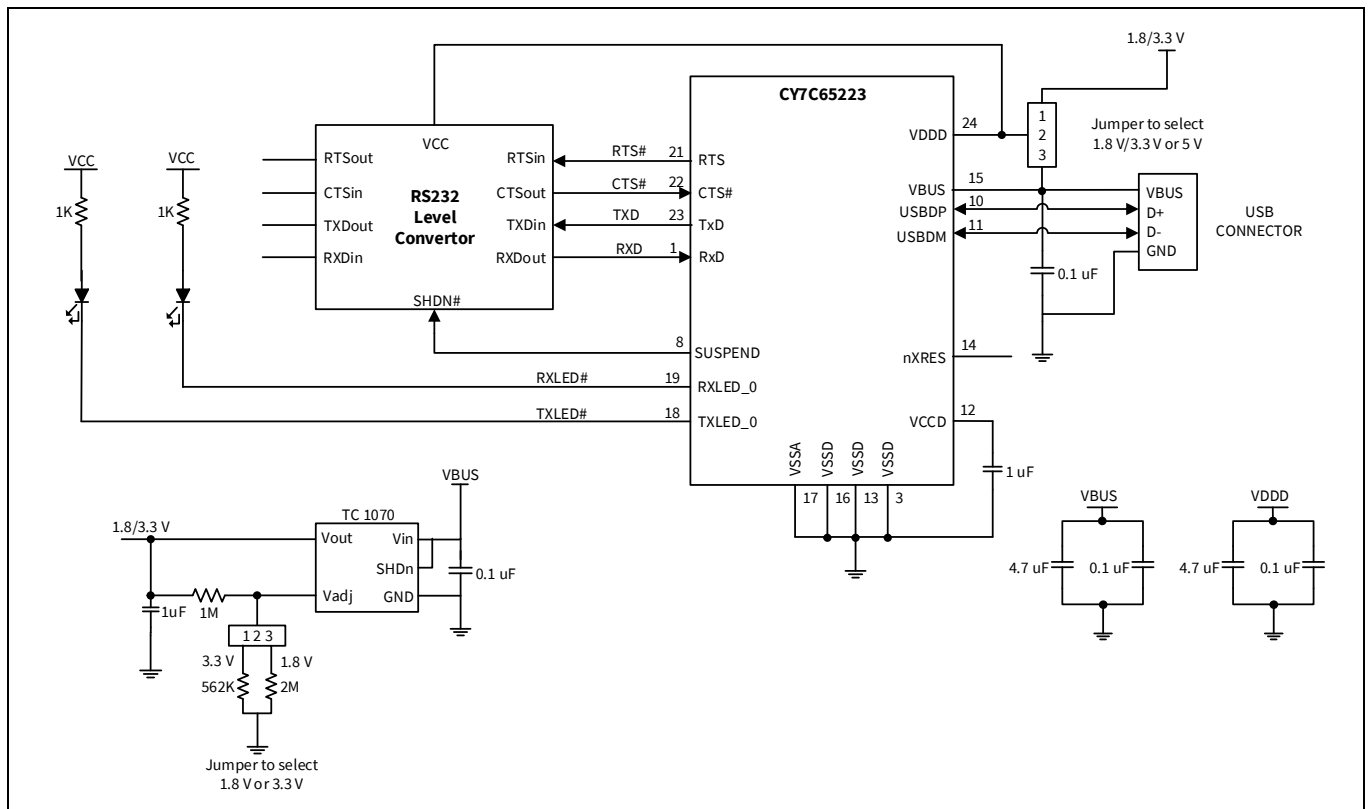

**Figure 6** USB to RS232 bridge

Application examples

## 7.2 USB to RS485 bridge

CY7C65223 can be configured as USB to UART interface. This UART interface operates at TTL level and it can be converted to RS485 interface using a GPIO and any half duplex RS485 transceiver IC (to convert TTL level to RS485 level) as shown in **Figure 7**. This GPIO (TXDEN) enables or disables the transmission of data through RS485 transceiver IC based on availability of character in UART buffer of CY7C65223. This GPIO can be configured using Infineon USB-Serial Configuration utility. **Figure 8** shows timing diagram of this GPIO.

RS485 is a multi-drop network – i.e. many devices can communicate with each other over a single two wire cable connection. The RS485 cable requires to be terminated at each end of the cable.

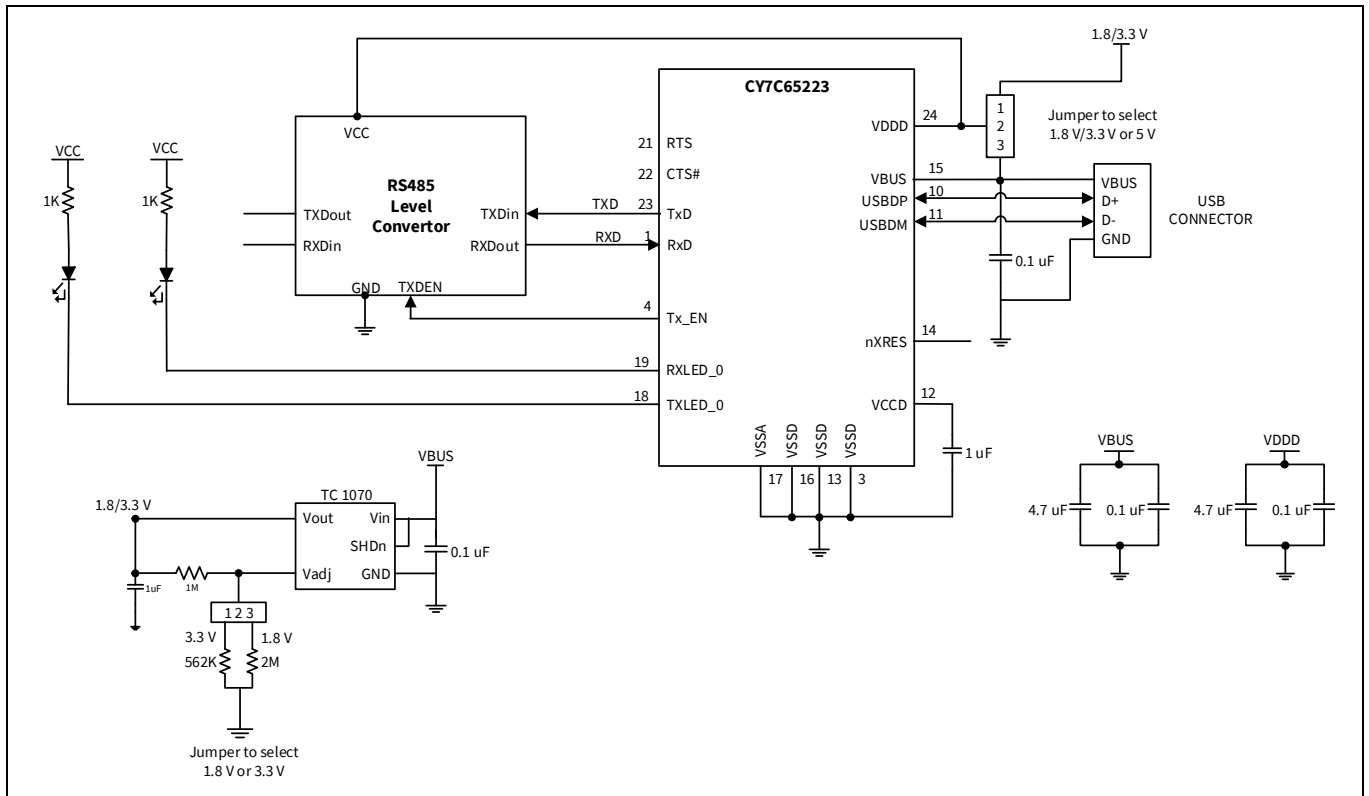

**Figure 7** USB to RS485 bridge

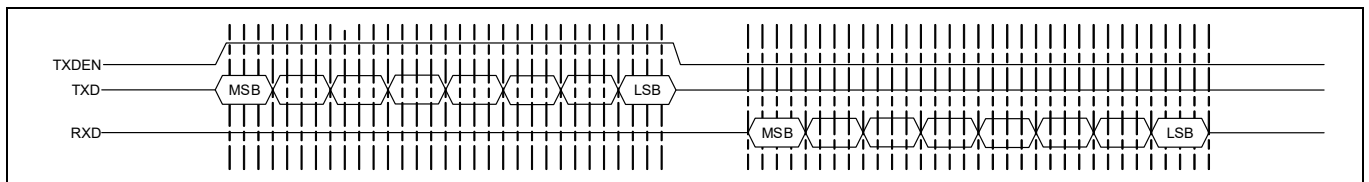

**Figure 8** RS485 GPIO (TXDEN) timing diagram

### 7.3 Battery-operated, bus-powered USB to MCU with Battery Charge Detection

**Figure 9** illustrates CY7C65223 as a USB-to-microcontroller interface. The TXD and RXD lines are used for data transfer, and the RTS# and CTS# lines are used for handshaking. The SUSPEND pin indicates to the MCU if the device is in USB Suspend, and the WAKEUP pin is used to wake up CY7C65223, which in turn issues a remote wakeup to the USB host.

This application illustrates a battery-operated system, which is bus-powered. CY7C65223 implements the battery charger detection functionality based on the USB Battery Charging Specification, Rev. 1.2.

Battery-operated bus power systems must comply with the following conditions:

- The system can be powered from the battery (if not discharged) and can be operational if the VBUS is not connected or powered down.
- The system should not draw more than 100 mA from the VBUS prior to USB enumeration and USB Suspend.
- The system should not draw more than 500 mA for SDP and 1.5 A for CDP/DCP

To comply with the first requirement, the VBUS from the USB host is connected to the battery charger as well as to CY7C65223, as shown in **Figure 9**. When the VBUS is connected, CY7C65223 initiates battery charger detection and indicates the type of USB charger over BCD0 and BCD1. If the USB charger is SDP or CDP, CY7C65223 enables a 1.5-k $\Omega$  pull-up resistor on the USBDP for Full-Speed enumeration. When the VBUS is disconnected, CY7C65223 indicates an absence of the USB charger over BCD0 and BCD1, and removes the 1.5-k $\Omega$  pull-up resistor on USBDP. Removing this resistor ensures that no current flows from the supply to the USB host through the USBDP, to comply with the USB 2.0 specification.

To comply with the second and third requirements, two signals (BCD0 and BCD1) are configured over GPIO to communicate the type of USB host charger and the amount of current it can draw from the battery charger. BCD0 and BCD1 signals can be configured using the configuration utility.

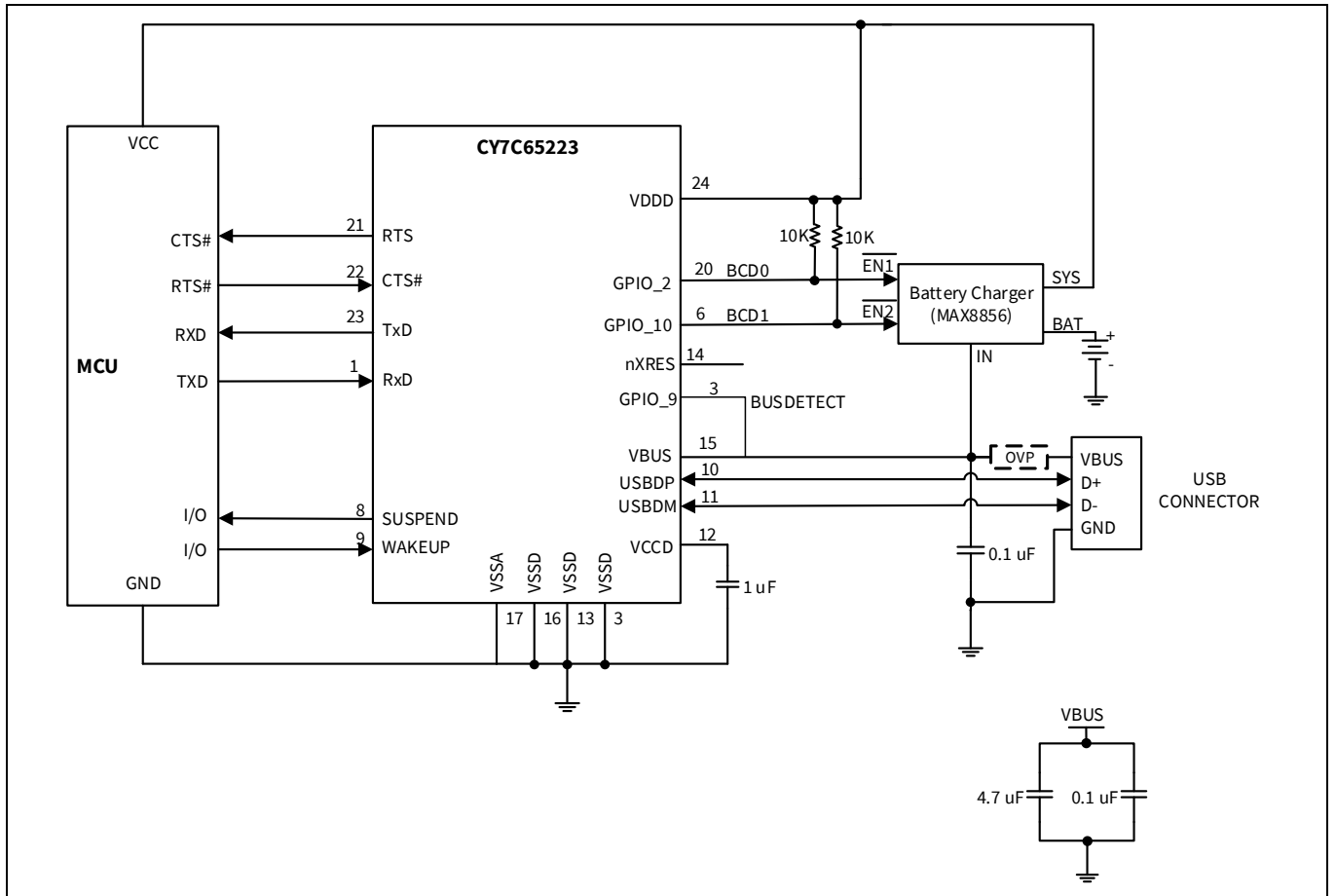

**Figure 9** USB to MCU Interface with Battery Charge Detection<sup>[7, 8, 9]</sup>

### Notes

7. Add a 100-k $\Omega$  pull-down resistor on the V<sub>BUS</sub> pin for quick discharge.
8. Refer [Figure 10](#), [Figure 11](#), [Figure 12](#) and the corresponding descriptions for handling VBUS Over Voltage Protection (OVP).
9. BCD and BUSDETECT functionality are not enabled by default. USB-Serial Configuration Utility is provided to enable BCD and BUSDETECT functionality.

## Application examples

In a battery charger system, a 9-V spike on the VBUS is possible. The CY7C65223 VBUS pin is intolerant to voltage above 6 V. In the absence of over-voltage protection (OVP) on the VBUS line, the VBUS should be connected to BUSDETECT (GPIO configured) using the resistive network and the output of the battery charger to the VBUS pin of CY7C65223, as shown in **Figure 10**.

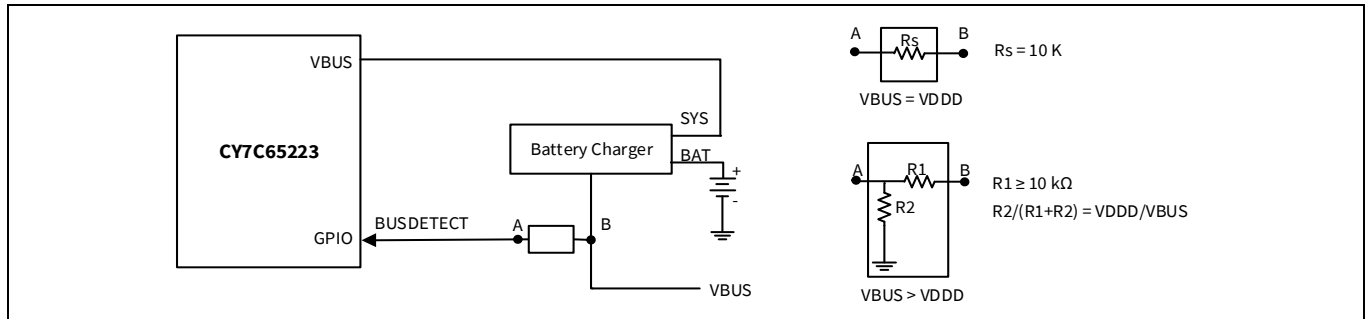

**Figure 10** 9-V tolerant

When the VBUS and VDD are at the same voltage potential, the VBUS can be connected to the GPIO using a series resistor ( $R_s$ ) (see **Figure 11**). If there is a charger failure and the VBUS becomes 9 V, then the 10-k $\Omega$  resistor plays two roles. It reduces the amount of current flowing into the forward-biased diodes in the GPIO, and it reduces the voltage seen on the pad.

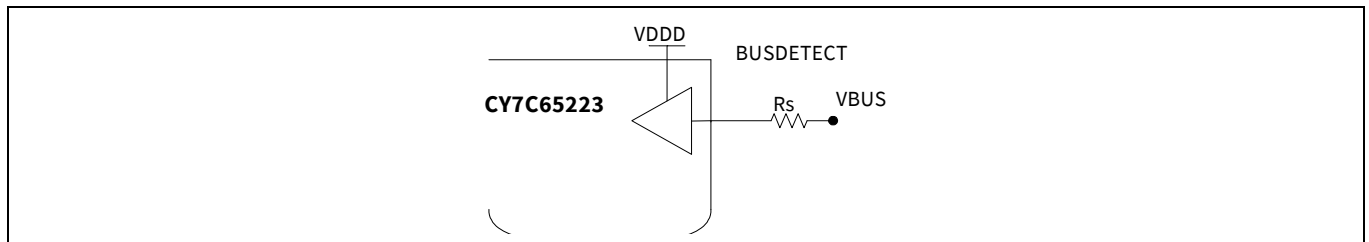

**Figure 11** GPIO VBUS detection, VBUS = VDD

When the VBUS > VDD, a resistor voltage divider is required to reduce the voltage from the VBUS down to VDD for the GPIO sensing the VBUS voltage (see **Figure 12**). The resistors should be sized as follows:

$$R_1 \geq 10 \text{ k}$$

$$R_2 / (R_1 + R_2) = VDD / VBUS$$

The first condition limits the voltage and current for the charger failure situation, as described in the previous paragraph, while the second condition allows for normal-operation VBUS detection.

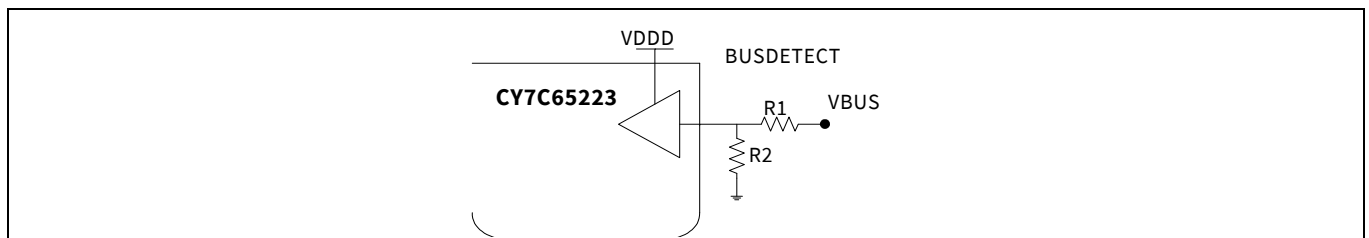

**Figure 12** GPIO VBUS detection, VBUS > VDD

Ordering information

## 8 Ordering information

**Table 17** lists the key package features and ordering codes of the CY7C65223. For more information, contact your local sales representative.

**Table 17 Key features and ordering information**

Package	Product	Operating range
24-pin QFN (4.00 × 4.00 × 0.55 mm, 0.5 mm pitch) (Pb-free)	CY7C65223-24LTXI	Industrial
24-pin QFN (4.00 × 4.00 × 0.55 mm, 0.5 mm pitch) (Pb-free)	CY7C65223-24LQXS	Automotive
24-pin QFN (4.00 × 4.00 × 0.55 mm, 0.5 mm pitch) (Pb-free) – Tape and Reel	CY7C65223-24LTXIT	Industrial
24-pin QFN (4.00 × 4.00 × 0.55 mm, 0.5 mm pitch) (Pb-free) – Tape and Reel	CY7C65223-24LQXST	Automotive

### 8.1 Ordering code definitions

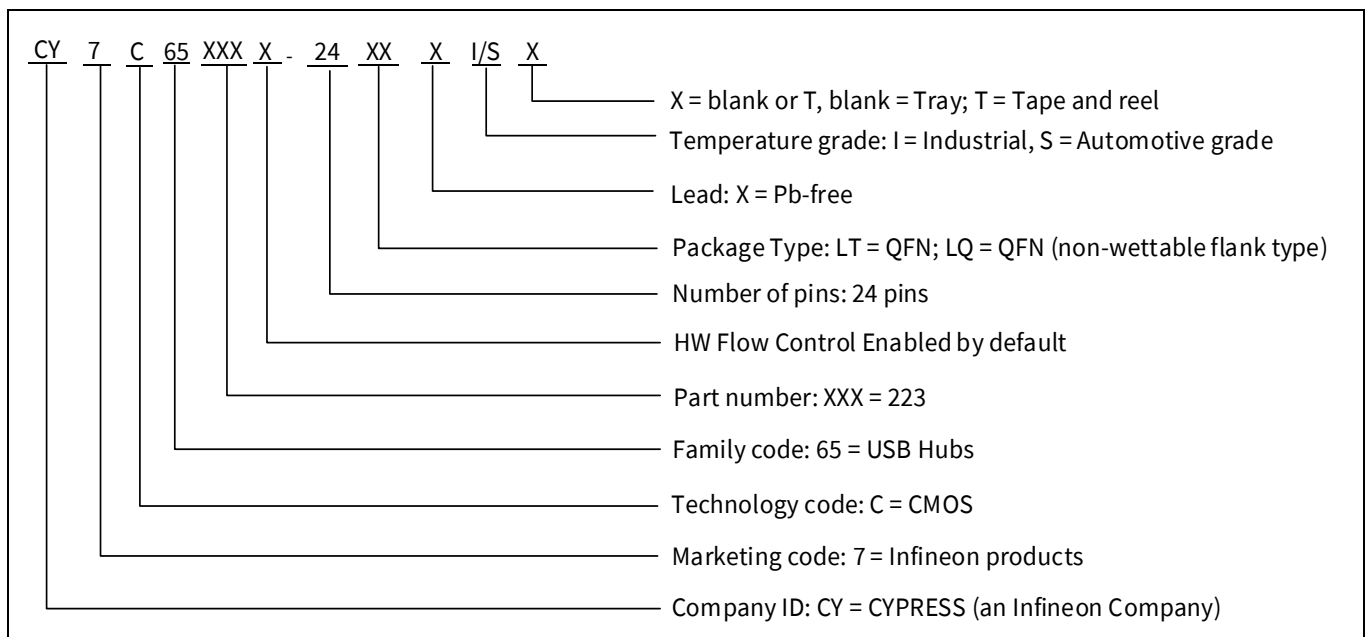

Package information

## 9 Package information

This device currently supports the 24-pin QFN package.

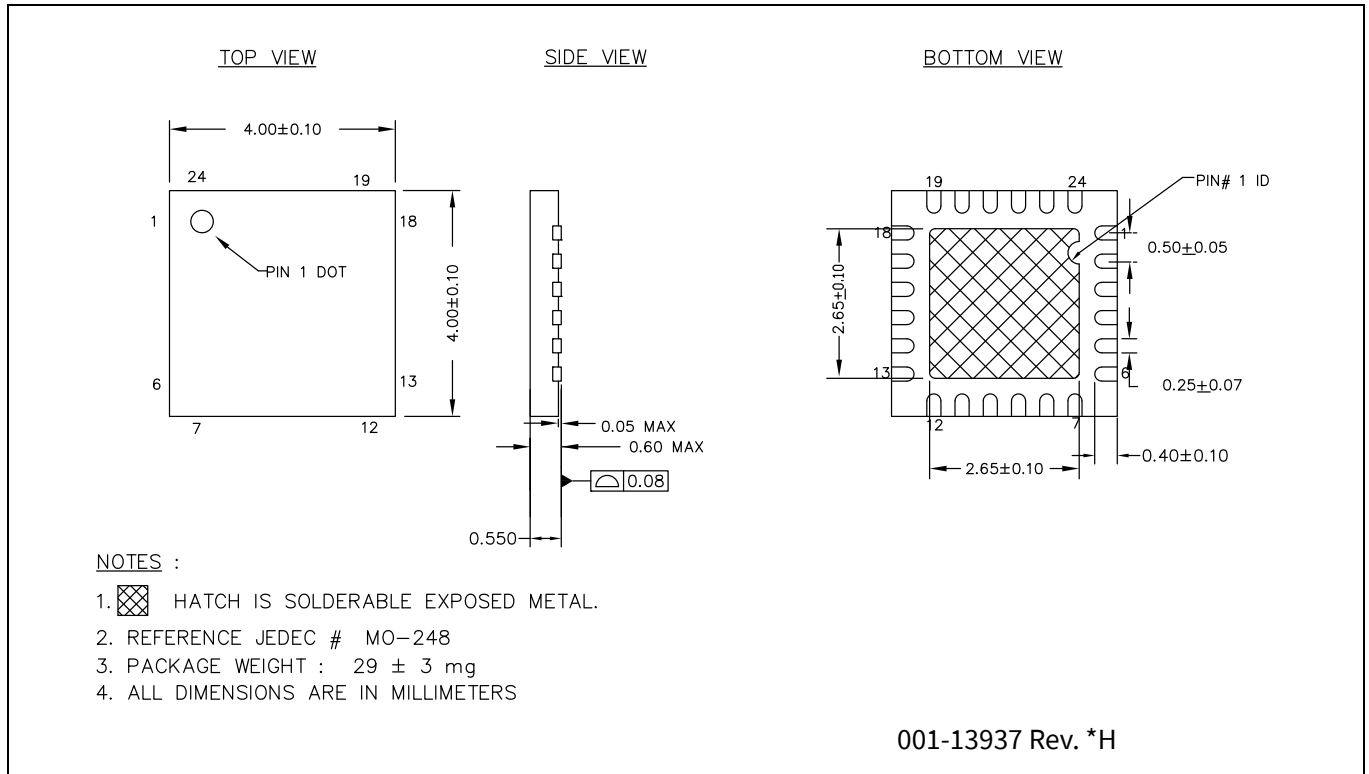

**Figure 13** 24-pin QFN ((4 × 4 × 0.60 mm) LQ24A/LQ24B 2.65 × 2.65 E-Pad (Sawn)) package outline (PG-VQFN-24), 001-13937

**Table 18** Package characteristics

Parameter	Description	Min	Typ	Max	Units
T <sub>A</sub>	Operating ambient temperature (industrial)	-40	25	85	°C
	Operating ambient temperature (automotive)	-40	25	105	
THJ	Package θ <sub>JA</sub>	-	18.4	-	°C/W

**Table 19** Solder reflow peak temperature

Package	Maximum peak temperature	Maximum time at peak temperature
24-pin QFN	260°C	30 seconds

**Table 20** Package moisture sensitivity level (MSL), IPC/JEDEC J-STD-2

Package	MSL
24-pin QFN	MSL 3



## 10 Acronyms

**Table 21** Acronyms used in this document

Acronym	Description
BCD	battery charger detection
CDC	communication driver class
CDP	charging downstream port
DCP	dedicated charging port
DLL	dynamic link library
ESD	electrostatic discharge
GPIO	general purpose input/output
HBM	human-body model
MCU	microcontroller unit
OSC	oscillator
PHDC	personal health care device class
PID	product identification
SCB	serial communication block
SDP	standard downstream port
SIE	serial interface engine
VCOM	virtual communication port
USB	Universal Serial Bus
UART	universal asynchronous receiver transmitter
VID	vendor identification

## 11 Document conventions

### 11.1 Units of measure

**Table 22** Units of measure

Symbol	Unit of measure
°C	degree Celsius
DMIPS	Dhrystone million instructions per second
kΩ	kilo-ohm
KB	kilobyte
kHz	kilohertz
kV	kilovolt
Mbps	megabits per second
MHz	megahertz
mm	millimeter
V	volt

## 12 Errata

This section describes the errata for the CY7C65223 USB-Serial family. Details include errata trigger conditions, scope of impact, and available workaround.

Contact your local Infineon Sales Representative if you have questions.

### Part numbers affected

Part number	Device characteristics
CY7C65223	All variants

### Qualification status

Production

### Errata summary

The following table defines the errata applicability to available USB-Serial devices.

Items	Affected part number	Fix status
[1.] <b>USB-Serial does not report UART Frame errors.</b>	CY7C65223	No fix
[2.] <b>USB-Serial does not report MARK or SPACE Parity errors.</b>	CY7C65223	No fix

#### 1. USB-Serial does not report UART Frame errors.

Problem Definition	USB-Serial does not report UART Frame Errors while receiving UART data when the number of stop bits is set as '1'.
Parameters Affected	NA
Trigger Condition(s)	USB-Serial fails to report a UART Frame error when the number of stop bits is set as '1'. It correctly reports the error when the stop bits is not '1'.
Scope of Impact	No impact
Workaround	No workaround. In general, applications using UART will have to include checksum or CRC in the data to ensure frame integrity.
Fix Status	No fix

#### 2. USB-Serial does not report MARK or SPACE Parity errors.

Problem Definition	USB-Serial does not report UART Parity error while receiving the data when configured for MARK or SPACE parity.
Parameters Affected	NA
Trigger Condition(s)	USB Serial fails to report UART Parity errors while receiving data when configured for MARK or SPACE parity. Note that USB-Serial detects parity errors when configured for ODD or EVEN parity settings.
Scope of Impact	No impact
Workaround	No workaround. In general, applications using UART will have to include checksum or CRC in the data to ensure frame integrity.
Fix Status	No fix

## Revision history

### Revision history

Document revision	Date	Description of changes
**	2020-11-26	Final datasheet (for NSO).
*A	2023-04-06	Updated Document Title to read as “CY7C65223, CY7C65223T, USB-UART single-channel bridge controller”. Added CY7C65223T part related information in all instances across the document. Updated <b>Ordering information</b> : Updated part numbers. Migrated to Infineon template.
*B	2024-02-20	Updated Document Title to read as “Auto CY7C65223, USB-UART Automotive single-channel bridge controller”. Removed CY7C65223T part related information in all instances across the document. Updated <b>Ordering information</b> : Updated part numbers. Updated to new template.

## Trademarks

All referenced product or service names and trademarks are the property of their respective owners.

**Edition 2024-02-20**

**Published by**

**Infineon Technologies AG  
81726 Munich, Germany**

**© 2024 Infineon Technologies AG.  
All Rights Reserved.**

**Do you have a question about this document?**

**Email:**

[erratum@infineon.com](mailto:erratum@infineon.com)

**Document reference**

**002-31599 Rev. \*B**

## IMPORTANT NOTICE

The information given in this document shall in no event be regarded as a guarantee of conditions or characteristics ("Beschaffenheitsgarantie").

With respect to any examples, hints or any typical values stated herein and/or any information regarding the application of the product, Infineon Technologies hereby disclaims any and all warranties and liabilities of any kind, including without limitation warranties of non-infringement of intellectual property rights of any third party.

In addition, any information given in this document is subject to customer's compliance with its obligations stated in this document and any applicable legal requirements, norms and standards concerning customer's products and any use of the product of Infineon Technologies in customer's applications.

The data contained in this document is exclusively intended for technically trained staff. It is the responsibility of customer's technical departments to evaluate the suitability of the product for the intended application and the completeness of the product information given in this document with respect to such application.

## WARNINGS

Due to technical requirements products may contain dangerous substances. For information on the types in question please contact your nearest Infineon Technologies office.

Except as otherwise explicitly approved by Infineon Technologies in a written document signed by authorized representatives of Infineon Technologies, Infineon Technologies' products may not be used in any applications where a failure of the product or any consequences of the use thereof can reasonably be expected to result in personal injury.