



Please note that Cypress is an Infineon Technologies Company.

The document following this cover page is marked as “Cypress” document as this is the company that originally developed the product. Please note that Infineon will continue to offer the product to new and existing customers as part of the Infineon product portfolio.

Continuity of document content

The fact that Infineon offers the following product as part of the Infineon product portfolio does not lead to any changes to this document. Future revisions will occur when appropriate, and any changes will be set out on the document history page.

Continuity of ordering part numbers

Infineon continues to support existing part numbers. Please continue to use the ordering part numbers listed in the datasheet for ordering.

Excelon LP 16-Mbit (2048K × 8) Serial (SPI) F-RAM

Features

- 16-Mbit ferroelectric random access memory (F-RAM) logically organized as 2048K × 8
 - Virtually unlimited endurance 1000 trillion (10^{15}) read/writes
 - 151-year data retention (See [Data Retention and Endurance on page 19](#))
 - NoDelay™ writes
 - Advanced high-reliability ferroelectric process
- Fast serial peripheral interface (SPI)
 - Up to 20 MHz frequency
 - Supports SPI mode 0 (0, 0) and mode 3 (1, 1)
- Sophisticated write protection scheme
 - Hardware protection using the Write Protect (\overline{WP}) pin
 - Software protection using Write Disable (WRDI) instruction
 - Software block protection for 1/4, 1/2, or entire array
- Device ID and Serial Number
 - Manufacturer ID and Product ID
 - Unique Device ID
 - Serial Number
- Dedicated 256-byte special sector F-RAM
 - Dedicated special sector write and read
 - Stored content can survive up to three standard reflow soldering cycles
- Low-power consumption
 - 1.50 mA (typ) active current at 20 MHz
 - 14 μ A (typ) standby current
 - 1.10 μ A (typ) Deep Power Down mode current
 - 0.1 μ A (typ) Hibernate mode current
 - 1.90 mA (typ) Inrush current during power up
- Low-voltage operation
 - CY15V116QI: $V_{DD} = 1.71$ V to 1.89 V
 - CY15B116QI: $V_{DD} = 1.8$ V to 3.6 V
- Commercial operating temperature: 0 °C to +70 °C
- 24-ball Fine Pitch Ball Grid Array (24-ball FBGA)
- Restriction of hazardous substances (RoHS) compliant

Functional Description

The Excelon LP CY15X116QI is a low power, 16-Mbit nonvolatile memory employing an advanced ferroelectric process. A ferroelectric random access memory or F-RAM is nonvolatile and performs reads and writes similar to a RAM. It provides reliable data retention for 151 years while eliminating the complexities, overhead, and system-level reliability problems caused by serial flash, EEPROM, and other nonvolatile memories.

Unlike serial flash and EEPROM, the CY15X116QI performs write operations at bus speed. No write delays are incurred. Data is written to the memory array immediately after each byte is successfully transferred to the device. The next bus cycle can commence without the need for data polling. In addition, the product offers substantial write endurance compared to other nonvolatile memories. The CY15X116QI is capable of supporting 10^{15} read/write cycles, or 1000 million times more write cycles than EEPROM.

These capabilities make the CY15X116QI ideal for nonvolatile memory applications, requiring frequent or rapid writes. Examples range from data collection, where the number of write cycles may be critical, to demanding industrial controls where the long write time of serial flash or EEPROM can cause data loss.

The CY15X116QI provides substantial benefits to users of serial EEPROM or flash as a hardware drop-in replacement. The CY15X116QI uses the high-speed SPI bus, which enhances the high-speed write capability of F-RAM technology. The device incorporates a read-only Device ID and Unique ID features, which allow the host to determine the manufacturer, product density, product revision, and unique ID for each part. The device also provides a writable, 8-byte serial number registers, which can be used to identify a specific board or a system.

For a complete list of related resources, [click here](#).

Logic Block Diagram

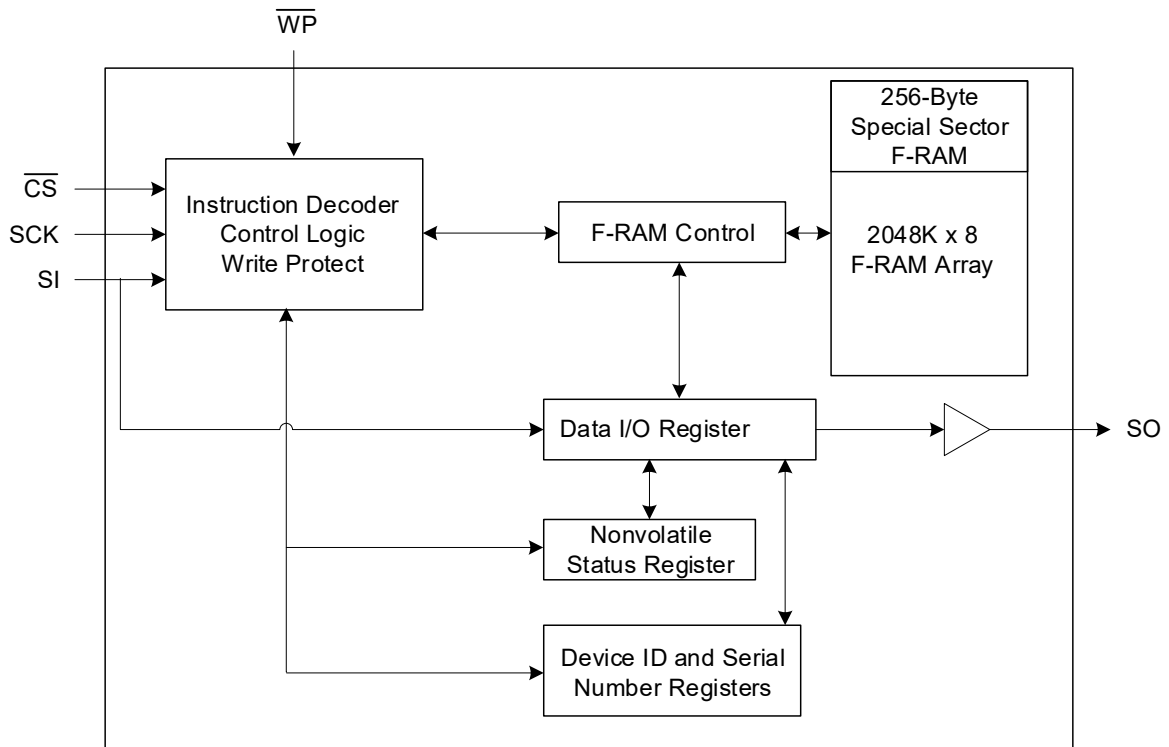

Contents

Pinouts	4	AC Test Conditions	19
Pin Definitions	4	AC Switching Characteristics	20
Functional Overview	5	Power Cycle Timing	22
Memory Architecture	5	Ordering Information	23
SPI Bus	5	Ordering Code Definitions	23
SPI Overview	5	Package Diagram	24
Terms used in SPI Protocol	5	Acronyms	25
SPI Modes	6	Document Conventions	25
Power-Up to First Access	6	Units of Measure	25
Functional Description	7	Document History Page	26
Command Structure	7	Sales, Solutions, and Legal Information	27
Maximum Ratings	17	Worldwide Sales and Design Support	27
Operating Range	17	Products	27
DC Electrical Characteristics	17	PSoC® Solutions	27
Data Retention and Endurance	19	Cypress Developer Community	27
Capacitance	19	Technical Support	27
Thermal Resistance	19		

Pinouts

Figure 1. 24-ball FBGA Pinout

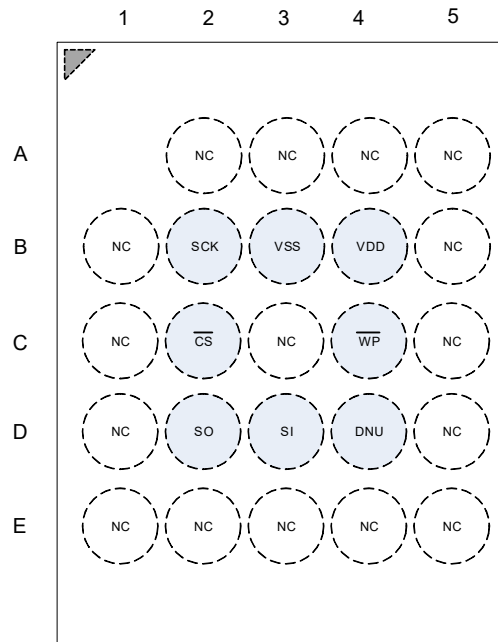

Pin Definitions

Pin Name	I/O Type	Description
$\overline{\text{CS}}$	Input	Chip Select. This active LOW input activates the device. When HIGH, the device enters low-power standby mode, ignores other inputs, and the output is tristated. When LOW, the device internally activates the SCK signal. A falling edge on $\overline{\text{CS}}$ must occur before every opcode.
SCK	Input	Serial Clock. All I/O activity is synchronized to the serial clock. Inputs are latched on the rising edge and outputs occur on the falling edge of the serial clock. The clock frequency may be any value between 0 and 20 MHz and may be interrupted at any time due to its synchronous behavior.
SI ^[1]	Input	Serial Input. All data is input to the device on this pin. The pin is sampled on the rising edge of SCK and is ignored at other times. It should always be driven to a valid logic level to meet the power (I_{DD}) specifications.
SO ^[1]	Output	Serial Output. This is the data output pin. It is driven during a read and remains tristated at all other times. Data transitions are driven on the falling edge of the serial clock SCK.
$\overline{\text{WP}}$	Input	Write Protect. This Active LOW pin prevents write operation to the Status Register when WPEN bit in the Status Register is set to '1'. This is critical because other write protection features are controlled through the Status Register. A complete explanation of write protection is provided in Status Register and Write Protection on page 9 . This pin has an internal weak pull-up resistor which keeps this pin HIGH if left floating (not connected on the board). This pin can also be tied to V_{DD} if not used.
DNU	Do Not Use	Do not use. Either leave this pin floating (not connected on the board) or tie to V_{DD} .
V_{SS}	Power supply	Ground for the device. Must be connected to the ground of the system.
V_{DD}	Power supply	Power supply input to the device.

Note

1. SI may be connected to SO for a single pin data interface.

Functional Overview

The CY15X116QI is a serial F-RAM memory. The memory array is logically organized as 1,048,576 × 8 bits and is accessed using an industry-standard serial peripheral interface (SPI) bus. The functional operation of the F-RAM is similar to serial flash and serial EEPROMs. The major difference between the CY15X116QI and a serial flash or EEPROM with the same pinout is the F-RAM's superior write performance, high endurance, and low power consumption.

Memory Architecture

When accessing CY15X116QI, the user addresses 1,024K locations of eight data bits each. These eight data bits are shifted in or out serially. The addresses are accessed using the SPI protocol, which includes a chip select (to permit multiple devices on the bus), an opcode, and a three-byte address. The upper four bits of the address range are 'don't care' values. The complete address of 20 bits specifies each byte address uniquely.

Most functions of the CY15X116QI are either controlled by the SPI interface or handled by on-board circuitry. The access time for the memory operation is essentially zero, beyond the time needed for the serial protocol. That is, the memory is read or written at the speed of the SPI bus. Unlike a serial flash or EEPROM, it is not necessary to poll the device for a ready condition because writes occur at bus speed. By the time a new bus transaction can be shifted into the device, a write operation is complete. This is explained in more detail in the interface section.

SPI Bus

The CY15X116QI is an SPI slave device and operates at speeds of up to 20 MHz. This high-speed serial bus provides high-performance serial communication to an SPI master. Many common microcontrollers have hardware SPI ports allowing a direct interface. It is simple to emulate the port using ordinary port pins for microcontrollers that do not have this feature. The CY15X116QI operates in SPI Modes 0 and 3.

SPI Overview

The SPI is a four-pin interface with Chip Select (\overline{CS}), Serial Input (SI), Serial Output (SO), and Serial Clock (SCK) pins.

The SPI is a synchronous serial interface, which uses clock and data pins for memory access and supports multiple devices on the data bus. A device on the SPI bus is activated using the \overline{CS} pin.

The relationship between chip select, clock, and data is dictated by the SPI mode. This device supports SPI modes 0 and 3. In both of these modes, data is clocked into the F-RAM on the rising edge of SCK starting from the first rising edge after \overline{CS} goes active.

The SPI protocol is controlled by opcodes. These opcodes specify the commands from the bus master to the slave device. After \overline{CS} is activated, the first byte transferred from the bus master is the opcode. Following the opcode, any addresses and data are then transferred. The \overline{CS} must go inactive after an operation is complete and before a new opcode can be issued.

Terms used in SPI Protocol

The commonly used terms in the SPI protocol are as follows.

SPI Master

The SPI master device controls the operations on the SPI bus. An SPI bus may have only one master with one or more slave devices. All the slaves share the same SPI bus lines and the master may select any of the slave devices using the \overline{CS} pin. All of the operations must be initiated by the master activating a slave device by pulling the \overline{CS} pin of the slave LOW. The master also generates the SCK and all the data transmission on SI and SO lines are synchronized with this clock.

SPI Slave

The SPI slave device is activated by the master through the Chip Select line. A slave device gets the SCK as an input from the SPI master and all the communication is synchronized with this clock. An SPI slave never initiates a communication on the SPI bus and acts only on the instruction from the master.

The CY15X116QI operates as an SPI slave and may share the SPI bus with other SPI slave devices.

Chip Select (\overline{CS})

To select any slave device, the master needs to pull down the corresponding \overline{CS} pin. Any instruction can be issued to a slave device only while the \overline{CS} pin is LOW. When the device is not selected, data through the SI pin is ignored and the serial output pin (SO) remains in a high-impedance state.

Note A new instruction must begin with the falling edge of \overline{CS} . Therefore, only one opcode can be issued for each active Chip Select cycle.

Serial Clock (SCK)

The serial clock is generated by the SPI master and the communication is synchronized with this clock after \overline{CS} goes LOW.

The CY15X116QI supports SPI modes 0 and 3 for data communication. In both of these modes, the inputs are latched by the slave device on the rising edge of SCK and outputs are issued on the falling edge. Therefore, the first rising edge of SCK signifies the arrival of the first Most Significant Bit (MSb) of an SPI instruction on the SI pin. Further, all data inputs and outputs are synchronized with SCK.

Data Transmission (SI/SO)

The SPI data bus consists of two lines, SI and SO, for serial data communication. SI is also referred to as Master Out Slave In (MOSI) and SO is referred to as Master In Slave Out (MISO). The master issues instructions to the slave through the SI pin, while the slave responds through the SO pin. Multiple slave devices may share the SI and SO lines as described earlier.

The CY15X116QI has two separate pins for SI and SO, which can be connected with the master as shown in Figure 2. For a microcontroller that has no dedicated SPI bus, a general-purpose port may be used. To reduce hardware resources on the controller, it is possible to connect the two data pins (SI, SO) together and tie off (HIGH) the \overline{WP} pin. Figure 3 shows such a configuration, which uses only three pins.

Figure 2. System Configuration with SPI Port

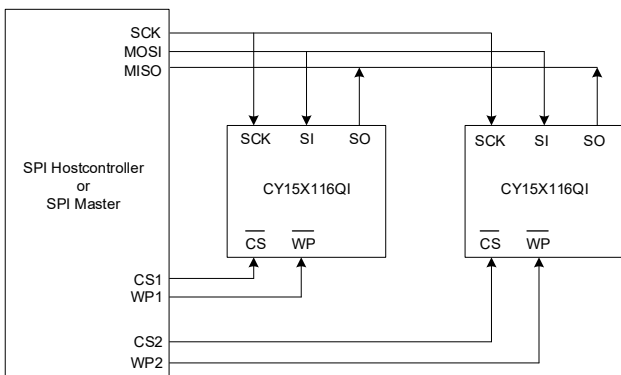
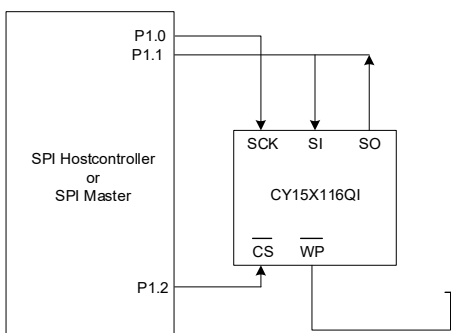

Figure 3. System Configuration without SPI Port



Most Significant Bit (MSb)

The SPI protocol requires that the first bit to be transmitted is the MSb. This is valid for both address and data transmission.

The 16-Mbit serial F-RAM requires a 3-byte address for any read or write operation. Because the address is only 20 bits, the first four bits, which are fed in are ignored by the device. Although these four bits are 'don't care', Cypress recommends that these bits be set to 0s to enable seamless transition to higher memory densities.

Serial Opcode

After the slave device is selected with \overline{CS} going LOW, the first byte received is treated as the opcode for the intended operation. CY15X116QI uses the standard opcodes for memory accesses.

Invalid Opcode

If an invalid opcode is received, the opcode is ignored and the device ignores any additional serial data on the SI pin until the next falling edge of \overline{CS} , and the SO pin remains tristated.

Status Register

CY15X116QI has an 8-bit Status Register. The bits in the Status Register are used to configure the device. These bits are described in Table 3 on page 9.

SPI Modes

CY15X116QI may be driven by a microcontroller with its SPI peripheral running in either of the following two modes:

- SPI Mode 0 (CPOL = 0, CPHA = 0)
- SPI Mode 3 (CPOL = 1, CPHA = 1)

For both these modes, the input data is latched in on the rising edge of SCK starting from the first rising edge after \overline{CS} goes active. If the clock starts from a HIGH state (in mode 3), the first rising edge after the clock toggles is considered. The output data is available on the falling edge of SCK. The two SPI modes are shown in Figure 4 and Figure 5. The status of the clock when the bus master is not transferring data is:

- SCK remains at 0 for Mode 0
- SCK remains at 1 for Mode 3

The device detects the SPI mode from the status of the SCK pin when the device is selected by bringing the \overline{CS} pin LOW. If the SCK pin is LOW when the device is selected, SPI Mode 0 is assumed and if the SCK pin is HIGH, it works in SPI Mode 3.

Figure 4. SPI Mode 0

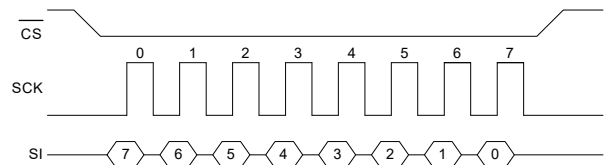
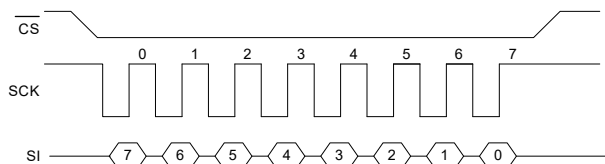

Figure 5. SPI Mode 3



Power-Up to First Access

The CY15X116QI is not accessible for a t_{PU} time after power-up. Users must comply with the timing parameter, t_{PU} , which is the minimum time from V_{DD} (min) to the first \overline{CS} LOW. Refer to Power Cycle Timing on page 22 for details.

Functional Description

Command Structure

There are 15 commands, called opcodes, that can be issued by the bus master to the CY15X116QI (see [Table 1](#)). These opcodes control the functions performed by the memory.

Table 1. Opcode Commands

Name	Description	Opcode	
		Hex	Binary
Write Enable Control			
WREN	Set write enable latch	06h	0000 0110b
WRDI	Reset write enable latch	04h	0000 0100b
Register Access			
RDSR	Read Status Register	05h	0000 0101b
WRSR	Write Status Register	01h	0000 0001b
Memory Write			
WRITE	Write memory data	02h	0000 0010b
Memory Read			
READ	Read memory data	03h	0000 0011b
FSTRD	Fast read memory data	0Bh	0000 1011b
Special Sector Memory Access			
SSWR	Special Sector Write	42h	0100 0010b
SSRD	Special Sector Read	4Bh	0100 1011b
Identification & Serial Number			
RDID	Read device ID	9Fh	1001 1111b
RUID	Read Unique ID	4Ch	0100 1100b
WRSN	Write Serial Number	C2h	1100 0010b
RDSN	Read Serial Number	C3h	11000 011b
Low Power Modes			
DPD	Enter Deep Power-Down	BAh	1011 1010b
HBN	Enter Hibernate Mode	B9h	1011 1001b
Reserved	Reserved	Unused opcodes are reserved for future use.	

Write Enable Control Commands

Set Write Enable Latch (WREN, 06h)

The CY15X116QI will power up with writes disabled. The WREN command must be issued before any write operation. Sending the WREN opcode allows the user to issue subsequent opcodes for write operations. These include writing to the Status Register (WRSR), the memory (WRITE), Special Sector (SSWR), and Write Serial Number (WRSN).

Sending the WREN opcode causes the internal Write Enable Latch to be set. A flag bit in the Status Register, called WEL, indicates the state of the latch. WEL = '1' indicates that writes are permitted. Attempting to write the WEL bit in the Status Register has no effect on the state of this bit - only the WREN opcode can set this bit. The WEL bit will be automatically cleared on the rising edge of CS following a WRDI, a WRSR, a WRITE, a SSWR, or a WRSN operation. This prevents further writes to the Status Register or the F-RAM array without another WREN command. [Figure 6](#) illustrates the WREN command bus configuration.

Figure 6. WREN Bus Configuration

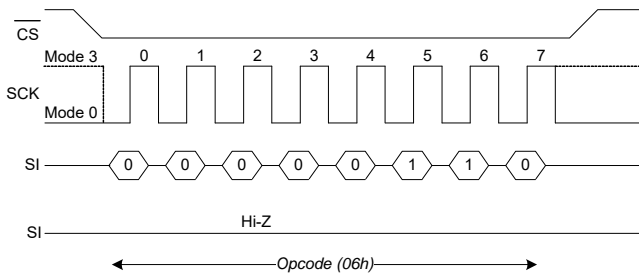

Reset Write Enable Latch (WRDI, 04h)

The WRDI command disables all write activity by clearing the Write Enable Latch. Verify that the writes are disabled by reading the WEL bit in the Status Register and verify that WEL is equal to '0'. [Figure 7](#) illustrates the WRDI command bus configuration.

Figure 7. WRDI Bus Configuration

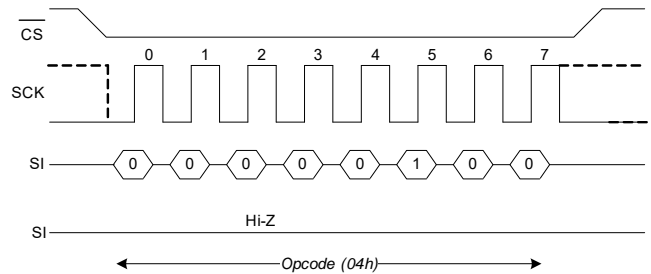

Register Access Commands

Status Register and Write Protection

The write protection features of the CY15X116QI are multi-tiered and are enabled through the status register. The Status Register is organized as follows (The default value shipped from the factory for WEL, BP0, BP1, bits 4–5, and WPEN is '0', and for bit 6 is '1').

Table 2. Status Register

Bit 7	Bit 6	Bit 5	Bit 4	Bit 3	Bit 2	Bit 1	Bit 0
WPEN (0)	X (1)	X (0)	X (0)	BP1 (0)	BP0 (0)	WEL (0)	X (0)

Table 3. Status Register Bit Definition

Bit	Definition	Description
Bit 0	Don't care	This bit is non-writable and always returns '0' upon read.
Bit 1 (WEL)	Write Enable	WEL indicates if the device is write enabled. This bit defaults to '0' (disabled) on power-up. WEL = '1' --> Write enabled WEL = '0' --> Write disabled
Bit 2 (BP0)	Block Protect bit '0'	Used for block protection. For details, see Table 4 .
Bit 3 (BP1)	Block Protect bit '1'	Used for block protection. For details, see Table 4 .
Bit 4–5	Don't care	These bits are non-writable and always return '0' upon read.
Bit 6	Don't care	This bit is non-writable and always returns '1' upon read.
Bit 7 (WPEN)	Write Protect Enable	Used to enable the function of Write Protect Pin (\overline{WP}). For details, see Table 5 .

Bits 0 and 4–5 are fixed at '0' and bit 6 is fixed at '1'; none of these bits can be modified. Note that bit 0 ("Ready or Write in progress" bit in serial flash and EEPROM) is unnecessary, as the F-RAM writes in real-time and is never busy, so it reads out as a '0'. An exception to this is when the device is waking up either from [Deep Power-Down Mode \(DPD, BAh\)](#) or [Hibernate Mode \(HBN, B9h\)](#). The BP1 and BP0 control the software write-protection features and are nonvolatile bits. The WEL flag indicates the state of the Write Enable Latch. Attempting to directly write the WEL bit in the Status Register has no effect on its state. This bit is internally set and cleared via the WREN and WRDI commands, respectively.

BP1 and BP0 are memory block write protection bits. They specify portions of memory that are write-protected as shown in [Table 4](#).

Table 4. Block Memory Write Protection

BP1	BP0	Protected Address Range
0	0	None
0	1	0x180000h to 0x1FFFFFFh (upper 1/4)
1	0	0x100000h to 0x1FFFFFFh (upper 1/2)
1	1	0x000000h to 0x1FFFFFFh (all)

The BP1 and BP0 bits and the Write Enable Latch are the only mechanisms that protect the memory from writes. The remaining write protection features protect inadvertent changes to the block protect bits.

The write protect enable bit (WPEN) in the Status Register controls the effect of the hardware write protect (\overline{WP}) pin. Refer to [Figure 23 on page 21](#) for the \overline{WP} pin timing diagram. When the WPEN bit is set to '0', the status of the \overline{WP} pin is ignored. When the WPEN bit is set to '1', a LOW on the \overline{WP} pin inhibits a write to the Status Register. Thus the Status Register is write-protected only when WPEN = '1' and \overline{WP} = '0'. [Table 5](#) summarizes the write protection conditions.

Table 5. Write Protection

WEL	WPEN	\overline{WP}	Protected Blocks	Unprotected Blocks	Status Register
0	X	X	Protected	Protected	Protected
1	0	X	Protected	Unprotected	Unprotected
1	1	0	Protected	Unprotected	Protected
1	1	1	Protected	Unprotected	Unprotected

Read Status Register (RDSR, 05h)

The RDSR command allows the bus master to verify the contents of the Status Register. Reading the status register provides information about the current state of the write-protection features. Following the RDSR opcode, the CY15X116QI will return one byte with the contents of the Status Register.

Figure 8. RDSR Bus Configuration

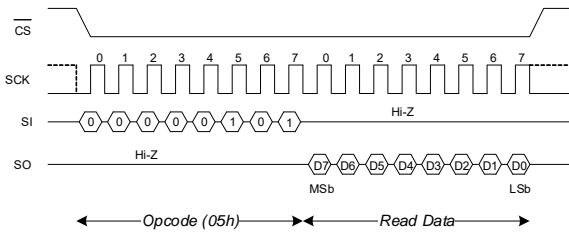

Write Status Register (WRSR, 01h)

The WRSR command allows the SPI bus master to write into the Status Register and change the write protect configuration by setting the WPEN, BP0, and BP1 bits as required. Before issuing a WRSR command, the WP pin must be HIGH or inactive. Note that on the CY15X116QI, WP only prevents writing to the Status Register, not the memory array. Before sending the WRSR command, the user must send a WREN command to enable writes. Executing a WRSR command is a write operation and therefore, clears the Write Enable Latch.

Figure 9. WRSR Bus Configuration (WREN not shown)

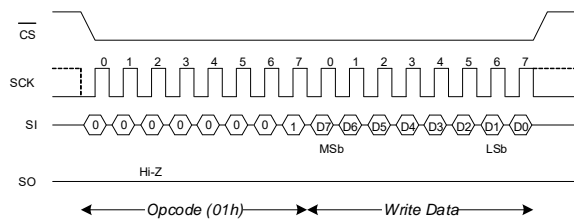

Memory Operation

The SPI interface, which is capable of a high clock frequency, highlights the fast write capability of the F-RAM technology. Unlike serial flash and EEPROMs, the CY15X116QI can perform sequential writes at bus speed. No page register is needed and any number of sequential writes may be performed.

Memory Write Operation Commands

Write Operation (WRITE, 02h)

All writes to the memory begin with a WREN opcode with CS being asserted and deasserted. The next opcode is WRITE. The WRITE opcode is followed by a three-byte address containing the 21-bit address (A20–A0) of the first data byte to be written into the memory. The upper four bits of the three-byte address are ignored. Subsequent bytes are data bytes, which are written sequentially. Addresses are incremented internally as long as the bus master continues to issue clocks and keeps CS LOW. If the last address of 1FFFFFFh is reached, the internal address counter will roll over to 00000h. Every data byte to be written is transmitted on SI in 8-clock cycles with MSb first and the Lsb last. The rising edge of CS terminates a write operation. The CY15X116QI write operation is shown in Figure 10.

Notes

- When a burst write reaches a protected block address, the automatic address increment stops and all the subsequent data bytes received for write will be ignored by the device. EEPROMs use page buffers to increase their write throughput. This compensates for the technology's inherently slow write operations. F-RAM memories do not have page buffers because each byte is written to the F-RAM array immediately after it is clocked in (after the eighth clock). This allows any number of bytes to be written without page buffer delays.
- If power is lost in the middle of the write operation, only the last completed byte will be written.

Figure 10. Memory Write (WREN not shown) Operation

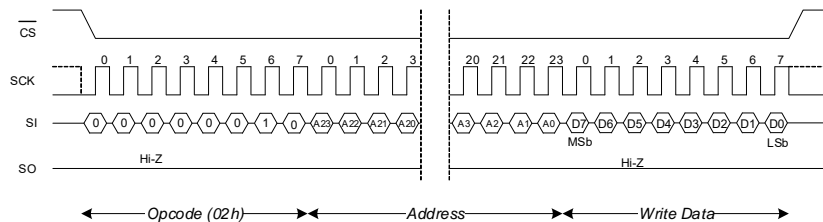

Memory Read Commands

Read Operation (READ, 03h)

After the falling edge of \overline{CS} , the bus master can issue a READ opcode. Following the READ command is a three-byte address containing the 21-bit address (A20–A0) of the first byte of the read operation. The upper four bits of the address are ignored. After the opcode and address are issued, the device drives out the read data on the next eight clocks. The SI input is ignored during read data bytes. Subsequent bytes are data bytes, which are read out sequentially. Addresses are incremented internally

as long as the bus master continues to issue clocks and \overline{CS} is LOW. If the last address of 1FFFFFh is reached, the internal address counter will roll over to 00000h. Every read data byte on SO is driven in 8-clock cycles with MSb first and the LSb last. The rising edge of \overline{CS} terminates a read operation and tristates the SO pin. The CY15X116QI read operation is shown in Figure 11.

Figure 11. Memory Read Operation

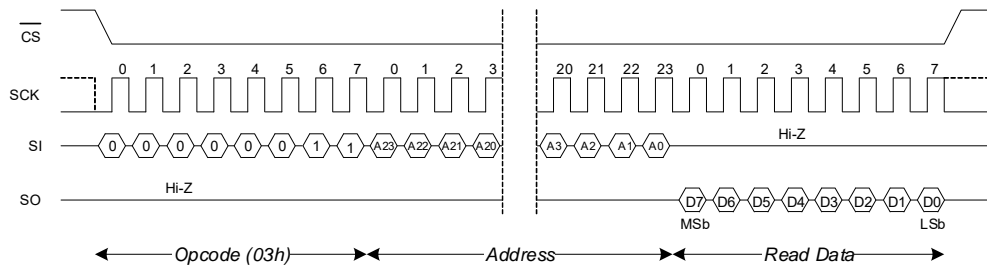

Fast Read Operation (FAST_READ, 0Bh)

The CY15X116QI supports a FAST READ opcode (0Bh) that is provided for opcode compatibility with serial flash devices. The FAST READ opcode is followed by a three-byte address containing the 21-bit address (A20–A0) of the first byte of the read operation and then a dummy byte. The dummy byte inserts a read latency of 8-clock cycle. The fast read operation is otherwise the same as an ordinary read operation except that it requires an additional dummy byte. After receiving the opcode, address, and a dummy byte, the CY15X116QI starts driving its SO line with data bytes, with MSb first, and continues transmitting as long as the device is selected and the clock is available. In case of bulk read, the internal address counter is incremented automatically, and after the last address 1FFFFFh is reached, the internal address counter rolls over to 00000h.

When the device is driving data on its SO line, any transition on its SI line is ignored. The rising edge of \overline{CS} terminates a fast read operation and tristates the SO pin. The CY15X116QI Fast Read operation is shown in Figure 12.

Note The dummy byte can be any 8-bit value but Axh (8'b1010xxxx). The lower 4 bits of Axh are don't care bits. Hence, Axh essentially represents 16 different 8-bit values which shouldn't be transmitted as the dummy byte. 00h is typically used as the dummy byte in most use cases.

Figure 12. Fast Read Operation

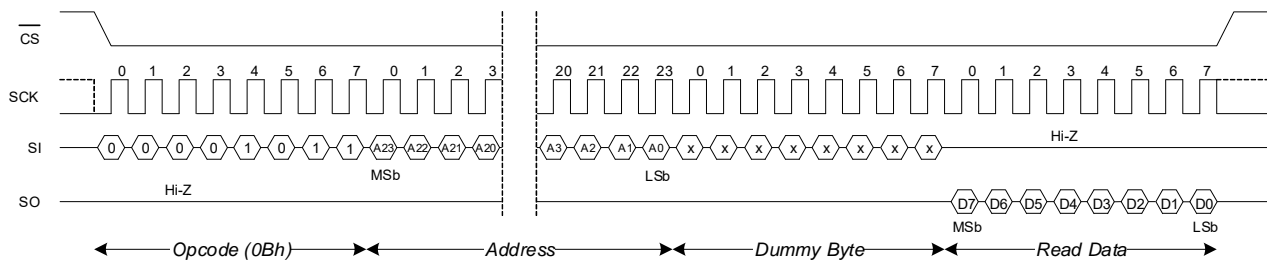

Special Sector Memory Access Commands

Special Sector Write (SSWR, 42h)

All writes to the 256-byte special begin with a WREN opcode with \overline{CS} being asserted and deasserted. The next opcode is SSWR. The SSWR opcode is followed by a three-byte address containing the 8-bit sector address (A7–A0) of the first data byte to be written into the special sector memory. The upper 16 bits of the three-byte address are ignored. Subsequent bytes are data bytes, which are written sequentially. Addresses are incremented internally as long as the bus master continues to issue clocks and keeps \overline{CS} LOW. Once the internal address counter auto increments to XXXFFh, \overline{CS} should toggle HIGH to terminate

the ongoing SSWR operation. Every data byte to be written is transmitted on SI in 8-clock cycles with MSb first and the LSB last. The rising edge of \overline{CS} terminates a write operation. The CY15X116QI special sector write operation is shown in Figure 13.

Notes

- If power is lost in the middle of the write operation, only the last completed byte will be written.
- The special sector F-RAM memory guarantees to retain data integrity up to three cycles of standard reflow soldering.

Figure 13. Special Sector Write (WREN not shown) Operation

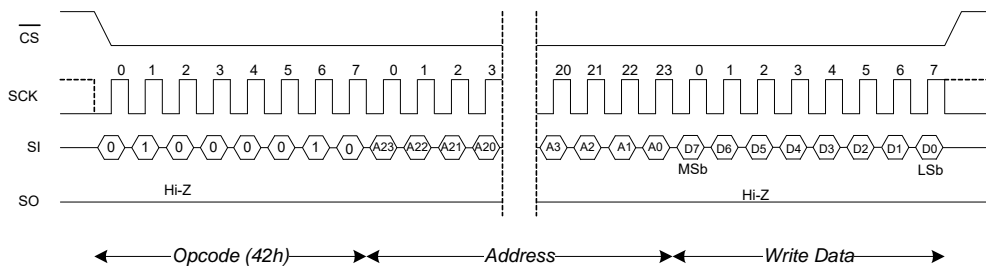

Special Sector Read (SSRD, 4Bh)

After the falling edge of \overline{CS} , the bus master can issue an SSRD opcode. Following the SSRD command is a three-byte address containing the 8-bit address (A7–A0) of the first byte of the special sector read operation. The upper 16 bits of the address are ignored. After the opcode and address are issued, the device drives out the read data on the next eight clocks. The SI input is ignored during read data bytes. Subsequent bytes are data bytes, which are read out sequentially. Addresses are incremented internally as long as the bus master continues to issue clocks and CS is LOW. Once the internal address counter auto increments to XXXFFh, \overline{CS} should toggle HIGH to terminate

the ongoing SSRD operation. Every read data byte on SO is driven in 8-clock cycles with MSb first and the LSB last. The rising edge of \overline{CS} terminates a special sector read operation and tristates the SO pin. The CY15X116QI special sector read operation is shown in Figure 14.

Note The special sector F-RAM memory guarantees to retain data integrity up to three cycles of standard reflow soldering.

Figure 14. Special Sector Read Operation

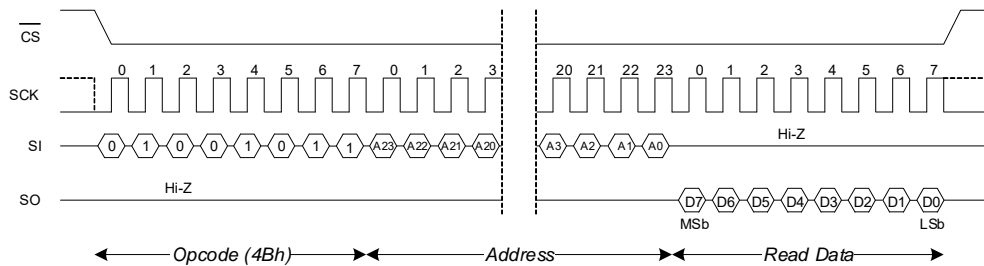

Identification and Serial Number Commands
Read Device ID (RDID, 9Fh)

The CY15X116QI device can be interrogated for its manufacturer, product identification, and die revision. The RDID opcode 9Fh allows the user to read the 9-byte manufacturer ID and product ID, both of which are read-only bytes. The JEDEC-assigned manufacturer ID places the Cypress (Ramtron) identifier in bank 7; therefore, there are six bytes of

the continuation code 7Fh followed by the single byte C2h. There are two bytes of product ID, which includes a family code, a density code, a sub code, and the product revision code. [Table 6](#) shows 9-Byte Device ID field description. Refer to [Ordering Information on page 23](#) for 9-Byte device ID of an individual part. The CY15X116QI read device ID operation is shown in [Figure 15](#).

Note The least significant data byte (Byte 0) shifts out first and the most significant data byte (Byte 8) shifts out last.

Table 6. 9-Byte Device ID

Device ID Field Description							
Manufacturer ID [71:16]	Family [15:13]	Density [12:9]	Inrush [8]	Sub Type [7:5]	Revision [4:3]	Voltage [2]	Frequency [1:0]
56-bit	3-bit	4-bit	1-bit	3-bit	2-bit	1-bit	2-bit

Refer to [Ordering Information on page 23](#) for 9-Byte device ID of an individual part.

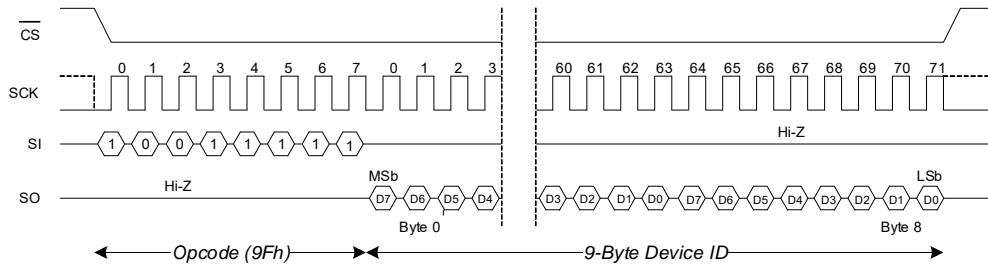
Figure 15. Read Device ID

Read Unique ID (RUID, 4Ch)

The CY15X102QN device can be interrogated for unique ID which is a factory programmed, 64-bit number unique to each device. The RUID opcode, 4Ch allows to read the 8-byte, read only unique ID. The CY15X102QN read unique ID operation is shown in [Figure 16](#).

Notes

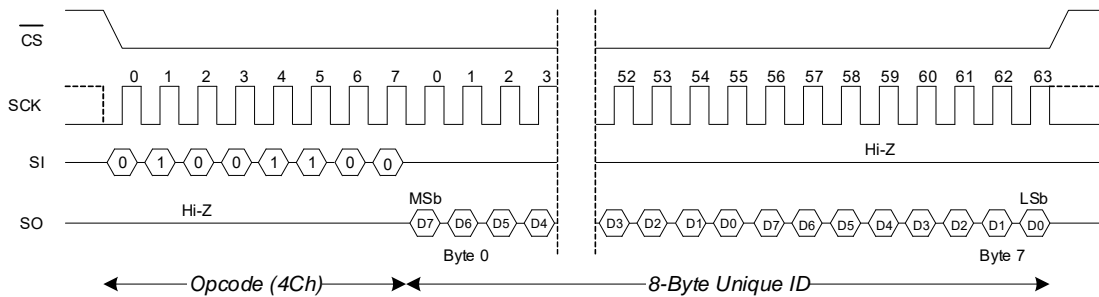
- The least significant data byte (Byte 0) shifts out first and the most significant data byte (Byte 7) shifts out last.
- The unique ID registers are guaranteed to retain data integrity of up to three cycles of the standard reflow soldering.

Figure 16. Read Unique ID

Write Serial Number (WRSN, C2h)

The serial number is an 8-byte one-time programmable memory space provided to the user to uniquely identify a PC board or a system. A serial number typically consists of a two-byte Customer ID, followed by five bytes of a unique serial number and one byte of CRC check. However, the end application can define its own format for the 8-byte serial number. All writes to the Serial Number Register begin with a WREN opcode with CS being asserted and deasserted. The next opcode is WRSN. The WRSN instruction can be used in burst mode to write all the

8 bytes of serial number. After the last byte of the serial number is shifted in, CS must be driven high to complete the WRSN operation. The CY15X116QI write serial number operation is shown in Figure 17.

Note The CRC checksum is not calculated by the device. The system firmware must calculate the CRC checksum on the 7-byte content and append the checksum to the 7-byte user-defined serial number before programming the 8-byte serial number into the serial number register. The factory default value for the 8-byte Serial Number is '0000000000000000h'.

Table 7. 8-Byte Serial Number

16-bit Customer Identifier		40-bit Unique Number					8-bit CRC
SN[63:56]	SN[55:48]	SN[47:40]	SN[39:32]	SN[31:24]	SN[23:16]	SN[15:8]	SN[7:0]

Figure 17. Write Serial Number (WREN not shown) Operation

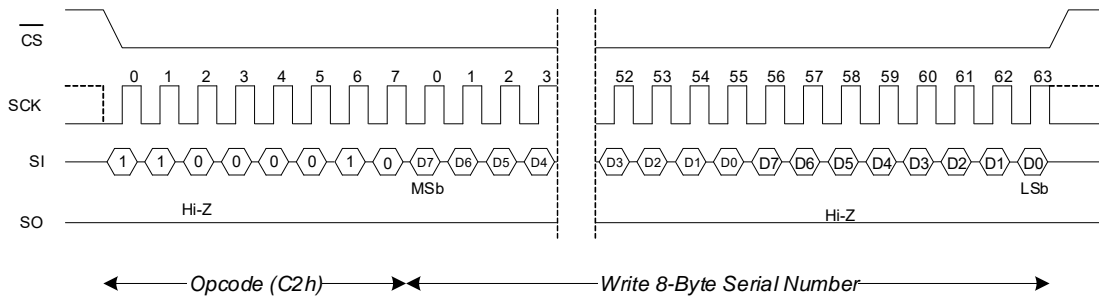

Read Serial Number (RDSN, C3h)

The CY15X116QI device incorporates an 8-byte serial space provided to the user to uniquely identify the device. The serial number is read using the RDSN instruction. A serial number read may be performed in burst mode to read all the eight bytes at once. After the last byte of the serial number is read, the device loops back to the first (MSb) byte of the serial number. An RDSN instruction can be issued by shifting the opcode for RDSN after CS goes LOW. The CY15X116QI read serial number operation is shown in Figure 18.

Note The least significant data byte (Byte 0) shifts out first and the most significant data byte (Byte 7) shifts out last.

Figure 18. Read Serial Number Operation

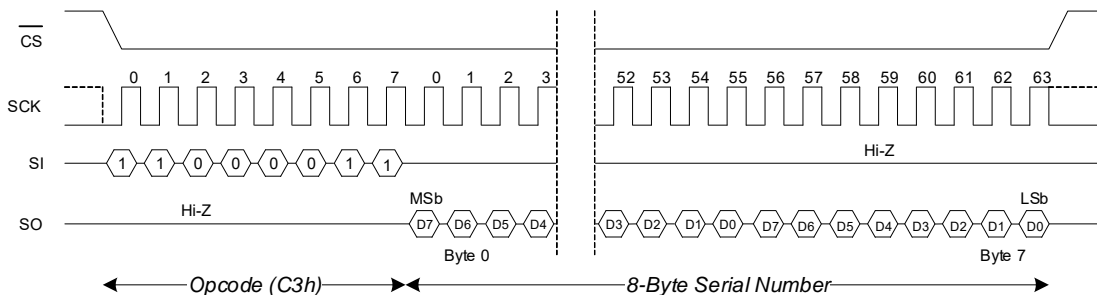

Low Power Mode Commands

Deep Power-Down Mode (DPD, BAh)

A power-saving Deep Power-Down mode is implemented on the CY15X116QI device. The device enters the Deep Power-Down mode after t_{ENTDPD} time after the DPD opcode BAh is clocked in and a rising edge of \overline{CS} is applied. When in Deep Power-Down

mode, the SCK and SI pins are ignored and SO will be Hi-Z, but the device continues to monitor the \overline{CS} pin.

A \overline{CS} pulse-width of t_{CSDPD} exits the DPD mode after t_{EXTDPD} time. The \overline{CS} pulse-width can be generated either by sending a dummy command cycle or toggling \overline{CS} alone while SCK and I/Os are don't care. The I/Os remain in hi-Z state during the wakeup from deep power down. Refer to Figure 19 for DPD entry and Figure 20 for DPD exit timing.

Figure 19. DPD Entry Timing

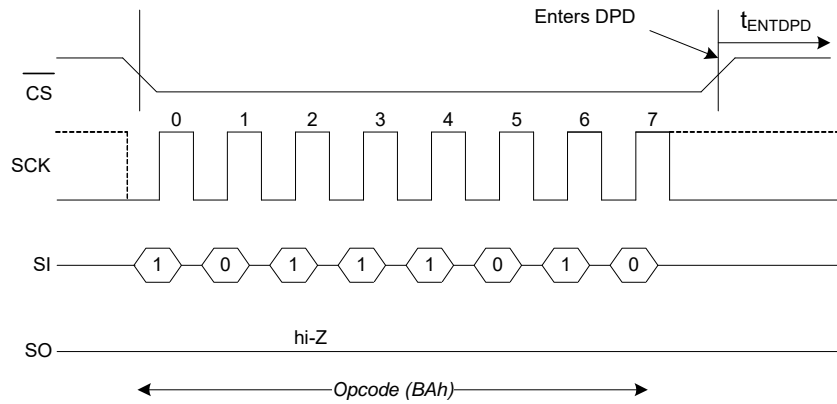
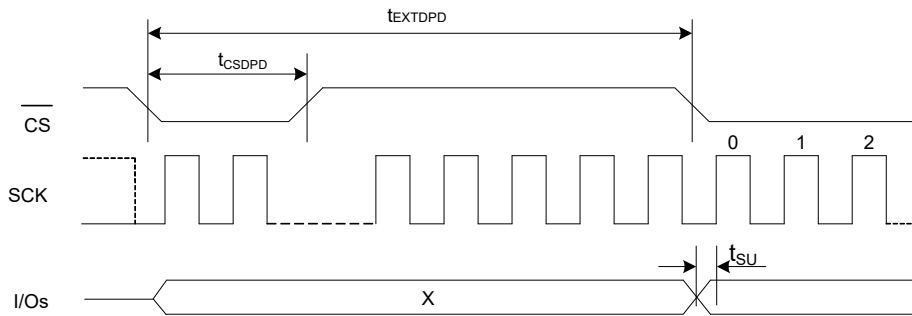

Figure 20. DPD Exit Timing



Hibernate Mode (HBN, B9h)

A lowest power Hibernate mode is implemented on the CY15X116QI device. The device enters Hibernate mode after t_{ENTHIB} time after the HBN opcode B9h is clocked in and a rising edge of CS is applied. When in Hibernate mode, the SCK and SI pins are ignored and SO will be Hi-Z, but the device continues to monitor the CS pin. On the next falling edge of CS, the device

will return to normal operation within t_{EXTHIB} time. The SO pin remains in a Hi-Z state during the wakeup from hibernate period. The device does not necessarily respond to an opcode within the wakeup period. To exit the Hibernate mode, the controller may send a “dummy” read, for example, and wait for the remaining t_{EXTHIB} time.

Figure 21. Hibernate Mode Operation

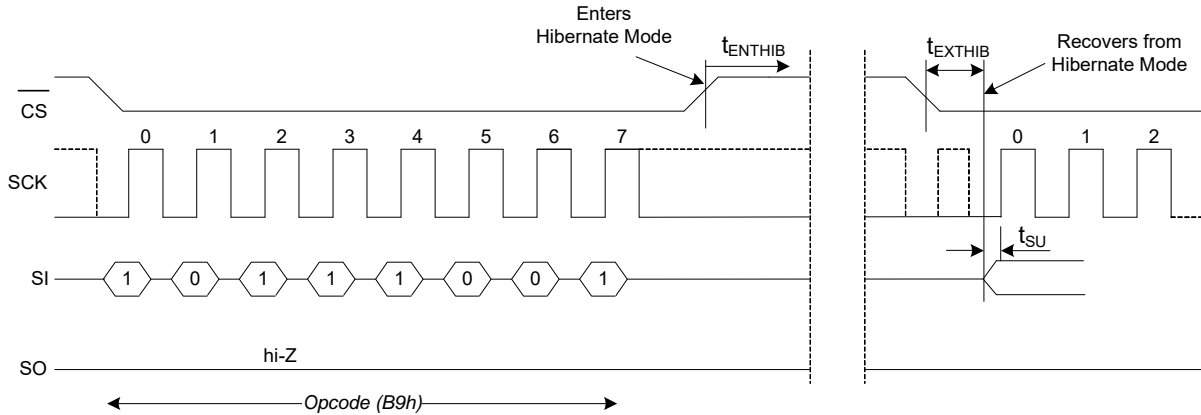

Endurance

The CY15X116QI devices are capable of being accessed at least 10^{15} times, reads or writes.

An F-RAM memory operates with a read and restore mechanism. Therefore, an endurance cycle is applied on a row basis for each access (read or write) to the memory array. The F-RAM architecture is based on an array of rows and columns of 256K rows of 64-bit each. The entire row is internally accessed once, whether a single byte or all eight bytes are read or written.

Each byte in the row is counted only once in an endurance calculation. Table 8 shows endurance calculations for a 64-byte repeating loop, which includes an opcode, a starting address, and a sequential 64-byte data stream. This causes each byte to experience one endurance cycle through the loop.

F-RAM read and write endurance is virtually unlimited at a 20-MHz clock rate.

Table 8. Time to Reach Endurance Limit for Repeating 64-byte Loop

SCK Freq (MHz)	Endurance Cycles/sec	Endurance Cycles/year	Years to Reach 10^{15} Limit
20	36,520	1.16×10^{12}	864
10	18,380	5.79×10^{11}	1727
5	9,190	2.90×10^{11}	3454

Maximum Ratings

Exceeding the maximum ratings may impair the useful life of the device. User guidelines are not tested.

Storage temperature	-65 °C to +125 °C
Maximum accumulated storage time	
At 125 °C ambient temperature	1000 h
At 85 °C ambient temperature	10 Years
Maximum junction temperature	125 °C
Supply voltage on V _{DD} relative to V _{SS} :	
CY15V116QI:	-0.5 V to +2.4 V
CY15B116QI:	-0.5 V to +4.1 V
Input voltage	V _{IN} ≤ V _{DD} + 0.5 V
DC voltage applied to outputs in High-Z state	-0.5 V to V _{DD} + 0.5 V
Transient voltage (< 20 ns) on any pin to ground potential	-2.0 V to V _{DD} + 2.0 V

Package power dissipation capability (T _A = 25 °C)	1.0 W
Surface mount lead soldering temperature (3 seconds)	+260 °C
DC output current (1 output at a time, 1s duration)	15 mA
Electrostatic discharge voltage	
Human Body Model (JEDEC Std JESD22-A114-B)	2 kV
Charged Device Model (JEDEC Std JESD22-C101-A)	500 V
Latch-up current	>140 mA

Operating Range

Device	Range	Ambient Temperature	V _{DD}
CY15V116QI	Commercial	0 °C to +70 °C	1.71 V to 1.89 V
CY15B116QI			1.8 V to 3.6 V

DC Electrical Characteristics

Over the [Operating Range](#)

Parameter	Description	Test Conditions	Min	Typ ^[2, 3]	Max	Unit	
V _{DD}	Power supply	CY15V116QI	1.71	1.8	1.89	V	
		CY15B116QI	1.8	3.3	3.6		
I _{DD}	V _{DD} supply current	V _{DD} = 1.71 V to 1.89 V; SCK toggling between V _{DD} - 0.2 V and V _{SS} ; other inputs V _{SS} or V _{DD} - 0.2 V. SO = Open	f _{SCK} = 1 MHz	-	0.60	0.80	mA
			f _{SCK} = 20 MHz	-	1.50	2.0	
		V _{DD} = 1.8 V to 3.6 V; SCK toggling between V _{DD} - 0.2 V and V _{SS} ; other inputs V _{SS} or V _{DD} - 0.2 V. SO = Open	f _{SCK} = 1 MHz	-	0.70	1.0	
			f _{SCK} = 20 MHz	-	1.80	2.40	
I _{SB}	V _{DD} standby current	V _{DD} = 1.71 V to 1.89 V; \overline{CS} = V _{DD} . All other inputs V _{SS} or V _{DD} .	-	14	142	μA	
		V _{DD} = 1.8 V to 3.6 V; \overline{CS} = V _{DD} . All other inputs V _{SS} or V _{DD} .	-	14	142.5		
I _{DPD}	Deep power-down current	V _{DD} = 1.71 V to 1.89 V; \overline{CS} = V _{DD} . All other inputs V _{SS} or V _{DD} .	-	1.10	14.40	μA	
		V _{DD} = 1.8 V to 3.6 V; \overline{CS} = V _{DD} . All other inputs V _{SS} or V _{DD} .	-	1.30	15.10		
I _{HBN}	Hibernate mode current	V _{DD} = 1.71 V to 1.89 V; \overline{CS} = V _{DD} . All other inputs V _{SS} or V _{DD} .	-	0.10	0.40	μA	
		V _{DD} = 1.8 V to 3.6 V; \overline{CS} = V _{DD} . All other inputs V _{SS} or V _{DD} .	-	0.10	0.75		

Notes

- Typical values are at 25 °C, V_{DD} = V_{DD} (typ).
- This parameter is guaranteed by characterization; not tested in production.

DC Electrical Characteristics (continued)

 Over the [Operating Range](#)

Parameter	Description	Test Conditions	Min	Typ ^[2, 3]	Max	Unit
I _{PEAK}	Peak current drawn from V _{DD} during power-up, wake up from Hibernate, wake up from Deep-power-Down, or Standby mode.	V _{DD} = 1.71 V to 1.89 V; $\overline{CS} = V_{DD}$. All other inputs V _{SS} or V _{DD} . Averaged over 10 μ s.	–	1.90	2.0 ^[4]	mA
		V _{DD} = 1.8 V to 3.60 V; $\overline{CS} = V_{DD}$. All other inputs V _{SS} or V _{DD} . Averaged over 10 μ s.	–	2.0	2.20 ^[4]	
I _{LI}	Input leakage current on I/O pins except WP pin	V _{SS} < V _{IN} < V _{DD}	–1	–	1	μ A
	Input leakage current on WP pin		–100	–	1	
I _{LO}	Output leakage current	V _{SS} < V _{OUT} < V _{DD}	–1	–	1	μ A
V _{IH}	Input HIGH voltage	–	0.7 × V _{DD}	–	V _{DD} + 0.3	V
V _{IL}	Input LOW voltage	–	–0.3	–	0.3 × V _{DD}	
V _{OH1}	Output HIGH voltage	I _{OH} = –1 mA, V _{DD} = 2.7 V.	2.4	–	–	
V _{OH2}	Output HIGH voltage	I _{OH} = –100 μ A	V _{DD} – 0.2	–	–	
V _{OL1}	Output LOW voltage	I _{OL} = 2 mA, V _{DD} = 2.7 V	–	–	0.4	
V _{OL2}	Output LOW voltage	I _{OL} = 150 μ A	–	–	0.2	

Notes

- Typical values are at 25 °C, V_{DD} = V_{DD} (typ).
- This parameter is guaranteed by characterization; not tested in production.

Data Retention and Endurance

Parameter	Description	Test condition	Min	Max	Unit
T _{DR}	Data retention	T _A = 85 °C	10	–	Years
		T _A = 70 °C	141	–	
		T _A = 60 °C	151	–	
		T _A = 50 °C	160	–	
NV _C	Endurance	Over operating temperature	10 ¹⁵	–	Cycles

Capacitance

For all packages.

Parameter ^[4]	Description	Test Conditions	Max	Unit
C _O	Output pin capacitance (SO)	T _A = 25 °C, f = 1 MHz, V _{DD} = V _{DD} (typ)	8	pF
C _I	Input pin capacitance		6	

Thermal Resistance

Parameter ^[4]	Description	Test Conditions	24-ball FBGA Package	Unit
Θ _{JA}	Thermal resistance (junction to ambient)	Test conditions follow standard test methods and procedures for measuring thermal impedance, per EIA/JESD51.	46.4	°C/W
Θ _{JC}	Thermal resistance (junction to case)		22.8	

AC Test Conditions

Input pulse levels 10% and 90% of V_{DD}
 Input rise and fall times 3 ns
 Input and output timing reference levels 0.5 × V_{DD}
 Output load capacitance 30 pF

Note

4. This parameter is guaranteed by characterization; not tested in production.

AC Switching Characteristics

Over the [Operating Range](#)

Parameters ^[5]		Description	Min	Max	Unit
Cypress Parameter	Alt. Parameter				
f_{SCK}	–	SCK clock frequency	0	20	MHz
t_{CH}	–	Clock HIGH time	22	–	ns
t_{CL}	–	Clock LOW time	22	–	
t_{CLZ} ^[6]	–	Clock LOW to Output low-Z	0	–	
t_{CSS}	t_{CSU}	Chip select setup	10	–	
t_{CSH}	t_{CSH}	Chip select hold - SPI mode 0	10	–	
t_{CSH1}	–	Chip select hold - SPI mode 3	10	–	
t_{HZCS} ^[7, 8]	t_{OD}	Output disable time	–	20	
t_{CO}	t_{ODV}	Output data valid time	–	20	
t_{OH}	–	Output hold time	1	–	
t_{CS}	t_D	Deselect time	60	–	
t_{SD}	t_{SU}	Data setup time	5	–	
t_{HD}	t_H	Data hold time	5	–	
t_{WPS}	t_{WHSL}	\overline{WP} setup time (w.r.t \overline{CS})	20	–	
t_{WPH}	t_{SHWL}	\overline{WP} hold time (w.r.t \overline{CS})	20	–	

Notes

5. Test conditions assume a signal transition time of 3 ns or less, timing reference levels of $0.5 \times V_{DD}$, input pulse levels of 10% to 90% of V_{DD} , and output loading of the specified I_{OL}/I_{OH} and 30-pF load capacitance shown in [AC Test Conditions on page 19](#).
6. Guaranteed by design.
7. t_{HZCS} is specified with a load capacitance of 5 pF. Transition is measured when the output enters a high-impedance state.
8. This parameter is guaranteed by characterization; not tested in production.

Figure 22. Synchronous Data Timing (Mode 0 and Mode 3)

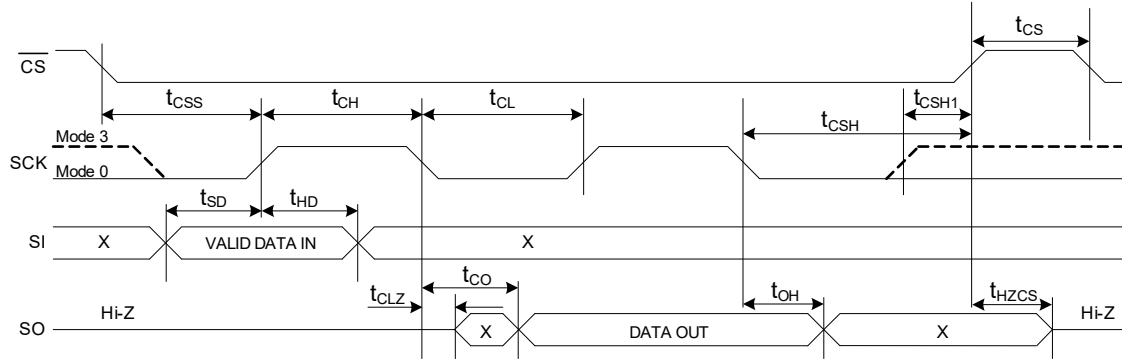
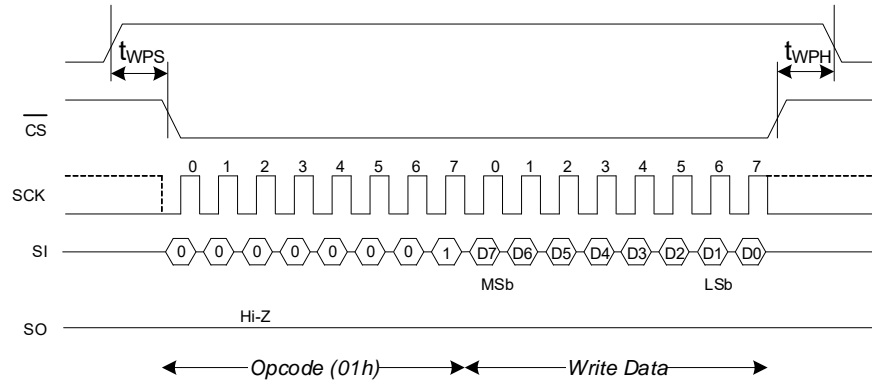

Figure 23. Write Protect Timing During Write Status Register (WRSR) Operation



Power Cycle Timing

Over the Operating Range

Parameters ^[9]		Description	Min	Max	Unit
Cypress Parameter	Alt. Parameter				
t_{PU}		Power-up $V_{DD(min)}$ to first access (\overline{CS} LOW)	6.0	–	ms
t_{VR} ^[10]		V_{DD} power-up ramp rate	30	–	$\mu\text{s/V}$
t_{VF} ^[10, 11]		V_{DD} power-down ramp rate	20	–	
t_{ENTDPD} ^[12]	t_{DP}	\overline{CS} high to enter deep power-down (\overline{CS} high to hibernate mode current)	–	3	μs
t_{CSDPD}		\overline{CS} pulse width to wake up from deep power-down mode	0.015	$4 \times 1/f_{SCK}$	
t_{EXTDPD}	t_{RDP}	Recovery time from deep power-down mode (\overline{CS} low to ready for access)	–	380	
t_{ENTHIB} ^[13]		Time to enter hibernate (\overline{CS} high to enter hibernate mode current)	–	3	
t_{EXTHIB}	t_{REC}	Recovery time from hibernate mode (\overline{CS} low to ready for access)	–	6.0	ms
$V_{DD(low)}$ ^[11]		Low V_{DD} where initialization must occur	0.6	–	V
t_{PD} ^[11]		$V_{DD(low)}$ time when $V_{DD(low)}$ at 0.6 V	130	–	μs
		$V_{DD(low)}$ time when $V_{DD(low)}$ at V_{SS}	70	–	

Figure 24. Power Cycle Timing

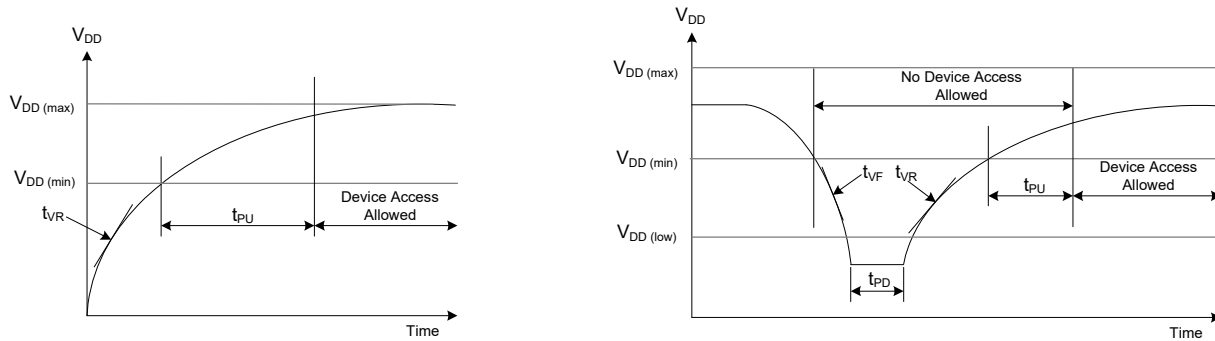

Notes

9. Test conditions assume a signal transition time of 3 ns or less, timing reference levels of $0.5 \times V_{DD}$, input pulse levels of 10% to 90% of V_{DD} , and output loading of the specified I_{OL}/I_{OH} and 30-pF load capacitance shown in [AC Test Conditions on page 19](#).
10. Slope measured at any point on the V_{DD} waveform.
11. This parameter is guaranteed by characterization; not tested in production.
12. Guaranteed by design. Refer to [Figure 19 on page 15](#) for Deep Power Down mode timing.
13. Guaranteed by design. Refer to [Figure 21 on page 16](#) for Hibernate mode timing.

Ordering Information

Ordering Code	Device ID	Package Diagram	Package Type	Operating Range
CY15B116QI-20BKXC	7F7F7F7F7F7FC231A1	001-97209	24-ball FBGA	Commercial
CY15V116QI-20BKXC	7F7F7F7F7F7FC231A5	001-97209	24-ball FBGA	Commercial

All these parts are Pb-free. Contact your local Cypress sales representative for availability of these parts.

Ordering Code Definitions

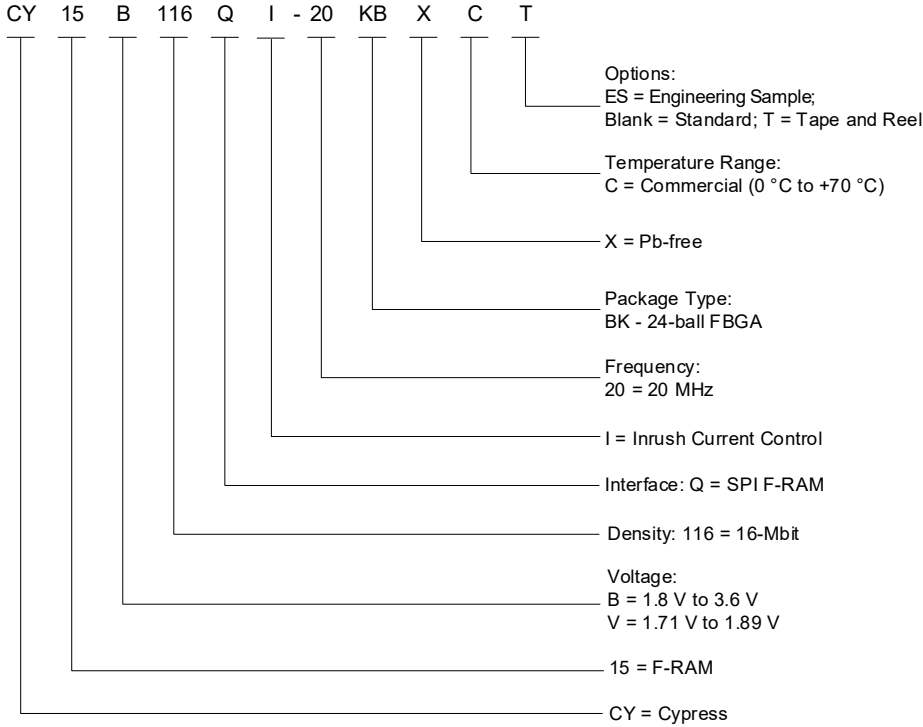

Package Diagram

Figure 25. 24L FBGA 8 × 6 × 1.2 mm BK24A, Package Outline, 001-97209

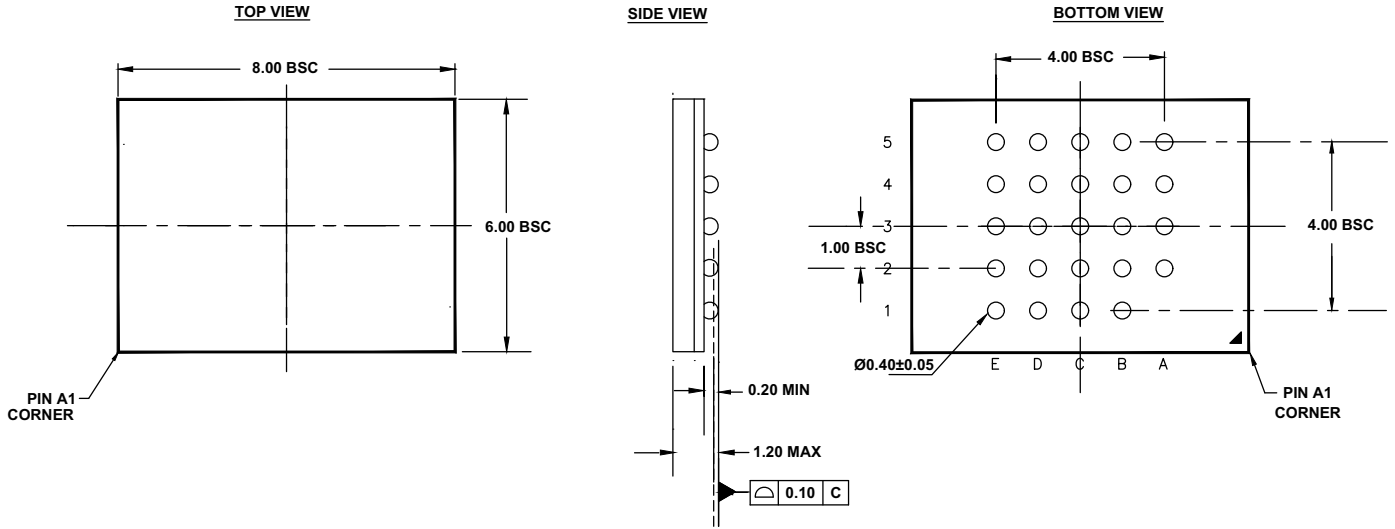

NOTES:

1. REFERENCE JEDEC # MO-216
2. ALL DIMENSIONS ARE IN MILLIMETERS

001-97209 *A

Acronyms

Table 9. Acronyms Used in this Document

Acronym	Description
CPHA	Clock Phase
CPOL	Clock Polarity
EEPROM	Electrically Erasable Programmable Read-Only Memory
EIA	Electronic Industries Alliance
FBGA	Fine-Pitch Ball Grid Array
F-RAM	Ferroelectric Random Access Memory
I/O	Input/Output
JEDEC	Joint Electron Devices Engineering Council
JESD	JEDEC standards
LSb	Least Significant Bit
MSb	Most Significant Bit
RoHS	Restriction of Hazardous Substances
SPI	Serial Peripheral Interface
SOIC	Small Outline Integrated Circuit

Document Conventions

Units of Measure

Table 10. Units of Measure

Symbol	Unit of Measure
°C	degree Celsius
Hz	hertz
kHz	kilohertz
kΩ	kilohm
Mbit	megabit
MHz	megahertz
μA	microampere
μF	microfarad
μs	microsecond
mA	milliampere
ms	millisecond
ns	nanosecond
W	ohm
%	percent
pF	picofarad
V	volt
W	watt

Document History Page

Document Title: CY15B116QI/CY15V116QI, Excelon LP 16-Mbit (2048K × 8) Serial (SPI) F-RAM Document Number: 002-30283			
Rev.	ECN No.	Submission Date	Description of Change
**	6879741	05/11/2020	Initial release.
*A	7041736	12/11/2020	Changed datasheet status to Preliminary. Updated standby mode current value. Updated tEXTDPD time 10 μA to 13 μA. Updated DC Electrical Characteristics and Thermal Resistance . Updated Ordering Information .

Sales, Solutions, and Legal Information

Worldwide Sales and Design Support

Cypress maintains a worldwide network of offices, solution centers, manufacturer's representatives, and distributors. To find the office closest to you, visit us at [Cypress Locations](#).

Products

Arm [®] Cortex [®] Microcontrollers	cypress.com/arm
Automotive	cypress.com/automotive
Clocks & Buffers	cypress.com/clocks
Interface	cypress.com/interface
Internet of Things	cypress.com/iot
Memory	cypress.com/memory
Microcontrollers	cypress.com/mcu
PSoC	cypress.com/psoc
Power Management ICs	cypress.com/pmic
Touch Sensing	cypress.com/touch
USB Controllers	cypress.com/usb
Wireless Connectivity	cypress.com/wireless

PSoC[®] Solutions

[PSoC 1](#) | [PSoC 3](#) | [PSoC 4](#) | [PSoC 5LP](#) | [PSoC 6 MCU](#)

Cypress Developer Community

[Community](#) | [Code Examples](#) | [Projects](#) | [Video](#) | [Blogs](#) | [Training](#) | [Components](#)

Technical Support

cypress.com/support

© Cypress Semiconductor Corporation, 2020. This document is the property of Cypress Semiconductor Corporation and its subsidiaries ("Cypress"). This document, including any software or firmware included or referenced in this document ("Software"), is owned by Cypress under the intellectual property laws and treaties of the United States and other countries worldwide. Cypress reserves all rights under such laws and treaties and does not, except as specifically stated in this paragraph, grant any license under its patents, copyrights, trademarks, or other intellectual property rights. If the Software is not accompanied by a license agreement and you do not otherwise have a written agreement with Cypress governing the use of the Software, then Cypress hereby grants you a personal, non-exclusive, nontransferable license (without the right to sublicense) (1) under its copyright rights in the Software (a) for Software provided in source code form, to modify and reproduce the Software solely for use with Cypress hardware products, only internally within your organization, and (b) to distribute the Software in binary code form externally to end users (either directly or indirectly through resellers and distributors), solely for use on Cypress hardware product units, and (2) under those claims of Cypress's patents that are infringed by the Software (as provided by Cypress, unmodified) to make, use, distribute, and import the Software solely for use with Cypress hardware products. Any other use, reproduction, modification, translation, or compilation of the Software is prohibited.

TO THE EXTENT PERMITTED BY APPLICABLE LAW, CYPRESS MAKES NO WARRANTY OF ANY KIND, EXPRESS OR IMPLIED, WITH REGARD TO THIS DOCUMENT OR ANY SOFTWARE OR ACCOMPANYING HARDWARE, INCLUDING, BUT NOT LIMITED TO, THE IMPLIED WARRANTIES OF MERCHANTABILITY AND FITNESS FOR A PARTICULAR PURPOSE. No computing device can be absolutely secure. Therefore, despite security measures implemented in Cypress hardware or software products, Cypress shall have no liability arising out of any security breach, such as unauthorized access to or use of a Cypress product. CYPRESS DOES NOT REPRESENT, WARRANT, OR GUARANTEE THAT CYPRESS PRODUCTS, OR SYSTEMS CREATED USING CYPRESS PRODUCTS, WILL BE FREE FROM CORRUPTION, ATTACK, VIRUSES, INTERFERENCE, HACKING, DATA LOSS OR THEFT, OR OTHER SECURITY INTRUSION (collectively, "Security Breach"). Cypress disclaims any liability relating to any Security Breach, and you shall and hereby do release Cypress from any claim, damage, or other liability arising from any Security Breach. In addition, the products described in these materials may contain design defects or errors known as errata which may cause the product to deviate from published specifications. To the extent permitted by applicable law, Cypress reserves the right to make changes to this document without further notice. Cypress does not assume any liability arising out of the application or use of any product or circuit described in this document. Any information provided in this document, including any sample design information or programming code, is provided only for reference purposes. It is the responsibility of the user of this document to properly design, program, and test the functionality and safety of any application made of this information and any resulting product. "High-Risk Device" means any device or system whose failure could cause personal injury, death, or property damage. Examples of High-Risk Devices are weapons, nuclear installations, surgical implants, and other medical devices. "Critical Component" means any component of a High-Risk Device whose failure to perform can be reasonably expected to cause, directly or indirectly, the failure of the High-Risk Device, or to affect its safety or effectiveness. Cypress is not liable, in whole or in part, and you shall and hereby do release Cypress from any claim, damage, or other liability arising from any use of a Cypress product as a Critical Component in a High-Risk Device. You shall indemnify and hold Cypress, its directors, officers, employees, agents, affiliates, distributors, and assigns harmless from and against all claims, costs, damages, and expenses, arising out of any claim, including claims for product liability, personal injury or death, or property damage arising from any use of a Cypress product as a Critical Component in a High-Risk Device. Cypress products are not intended or authorized for use as a Critical Component in any High-Risk Device except to the limited extent that (i) Cypress's published data sheet for the product explicitly states Cypress has qualified the product for use in a specific High-Risk Device, or (ii) Cypress has given you advance written authorization to use the product as a Critical Component in the specific High-Risk Device and you have signed a separate indemnification agreement.

Cypress, the Cypress logo, Spansion, the Spansion logo, and combinations thereof, WICED, PSoC, CapSense, EZ-USB, F-RAM, and Traveo are trademarks or registered trademarks of Cypress in the United States and other countries. For a more complete list of Cypress trademarks, visit cypress.com. Other names and brands may be claimed as property of their respective owners.