

Index

Page	Schematics Page Name
01	Cover Sheet / Revision History
02	Top Level
03	Freewheeling
04	Driver
05	Switches
06	Input Stage
07	Miscellaneous

01_Revision_History.SchDoc

Revision History

Rev.	Rel.	Date	Author	Description	Page(s)
1.0	RC01	07/2018	KP	- Initial design	7
1.1	RC01	01/2020	KP	- Formatting of Schematic	7

Battery Switch 12V

12V_Version

1.0



Infineon Technologies AG

ATV SYS SAE HW

Am Campeon 1-15 - 85579 Neubiberg - Germany

07/2018

Link to Top Level Document

02_Top Level
02_Battery_Switch_12V.SchDoc

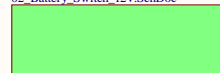

LEGAL DISCLAIMER

THE INFORMATION GIVEN IN THIS DOCUMENT IS GIVEN FOR ILLUSTRATING PURPOSES ONLY. THE RECIPIENT OF THIS DOCUMENT MUST VERIFY ANY FUNCTION DESCRIBED HEREIN IN THE REAL APPLICATION. INFINEON TECHNOLOGIES HEREBY DISCLAIMS ANY AND ALL WARRANTIES AND LIABILITIES OF ANY KIND (INCLUDING WITHOUT LIMITATION WARRANTIES OF NON-INFRINGEMENT OF INTELLECTUAL PROPERTY RIGHTS OF ANY THIRD PARTY) WITH RESPECT TO ANY AND ALL INFORMATION GIVEN IN THIS DOCUMENT.

Restricted

infineon		Infineon Technologies AG	
		ATV SYS SAE HW	
		Am Campeon 1-15 - 85579 Neubiberg - Germany	
Title		Battery Switch 12V	
Variant		12V_Version	Approved
Size:	Document Name	Rel.	Rev.
A3	01_Revision_History.SchDoc	KP	1.0
Author: KP		SVN Revision: Not in version control	
Date: 23.10.2020 Time: 14:55:07		© Infineon Technologies AG 2014. All Rights Reserved.	
		Sheet	of 7

02_Battery_Switch_12V.SchDoc

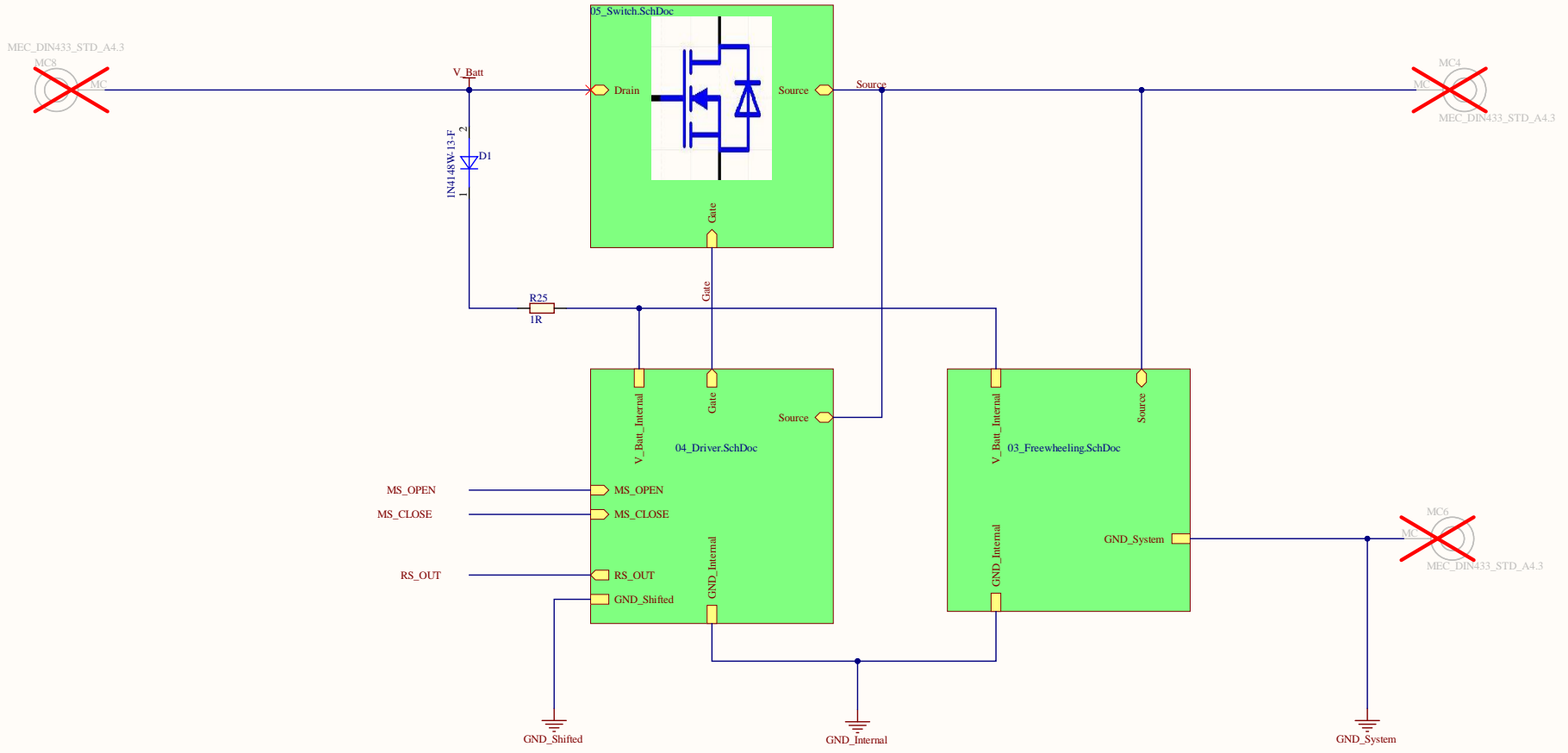

Link to Miscellaneous Document

Miscellaneous
Miscellaneous.SchDoc

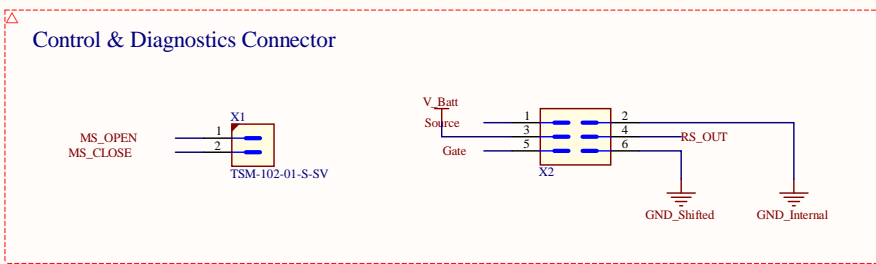
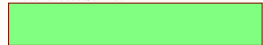

Restricted

Infineon		Infineon Technologies AG	
ATV SYS SAE HW		Am Campeon 1-15 - 85579 Neuberg - Germany	
Title: Battery Switch 12V			
Variant: 12V_Version			Approved: _
Size: A3	Document Name: 02_Battery_Switch_12V.SchDoc	Rel. KP	Rev. 1.0
Author: KP			
Date: 23.10.2020		Time: 14:55:07	SVN Revision: Not in version control
© Infineon Technologies AG 2014. All Rights Reserved. Sheet 8 of 7			

03_Freewheeling.SchDoc

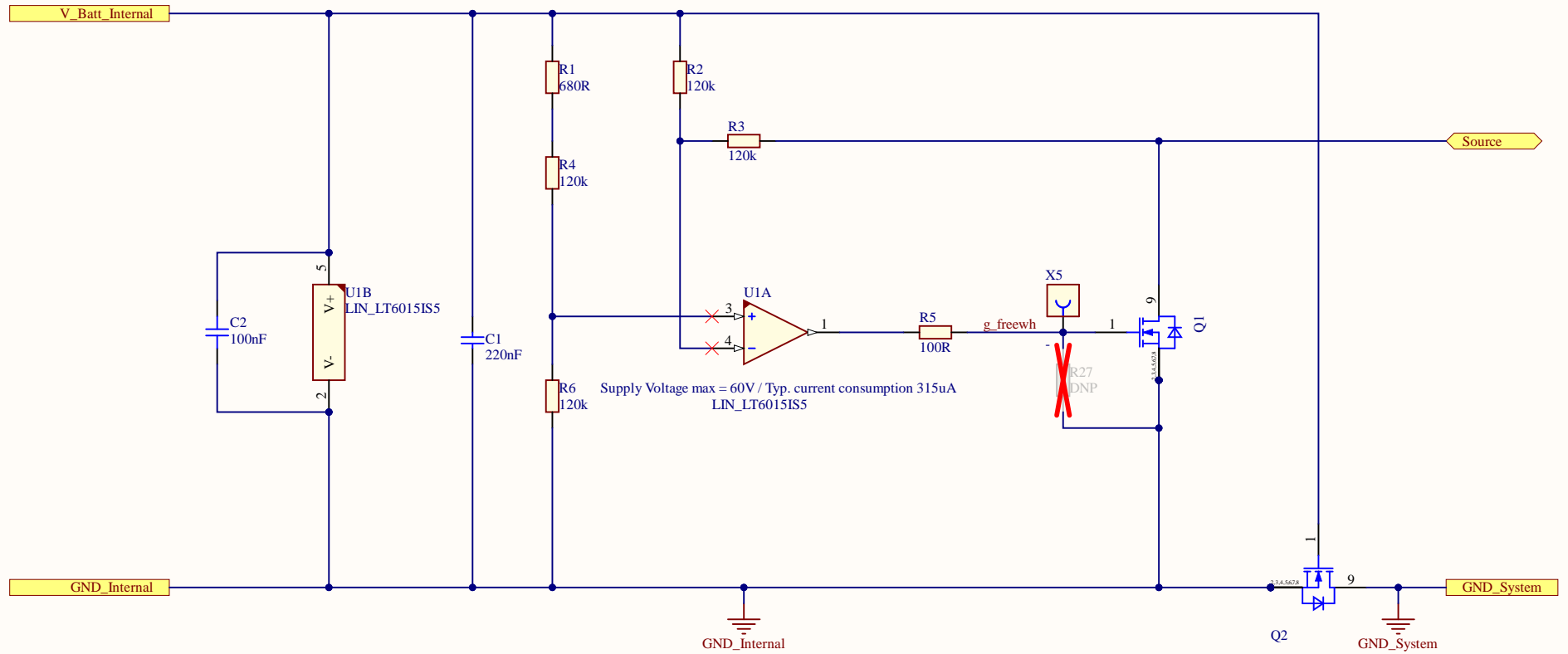

Restricted

Infineon Infineon Technologies AG
ATV SYS SAE HW
Am Campeon 1-15 - 85579 Neubiberg - Germany

Title		Battery Switch 12V	
Variant		12V_Version	Approved _
Size:	Document Name	Rel.	Rev.
A4	03_Freewheeling.SchDoc	KP	1.0
Author: KP			
Date: 23.10.2020 Time: 14:55:08		SVN Revision: Not in version control	
© Infineon Technologies AG 2014. All Rights Reserved.			Sheet of 7

04_Driver.SchDoc

A

B

C

D

A

B

C

D

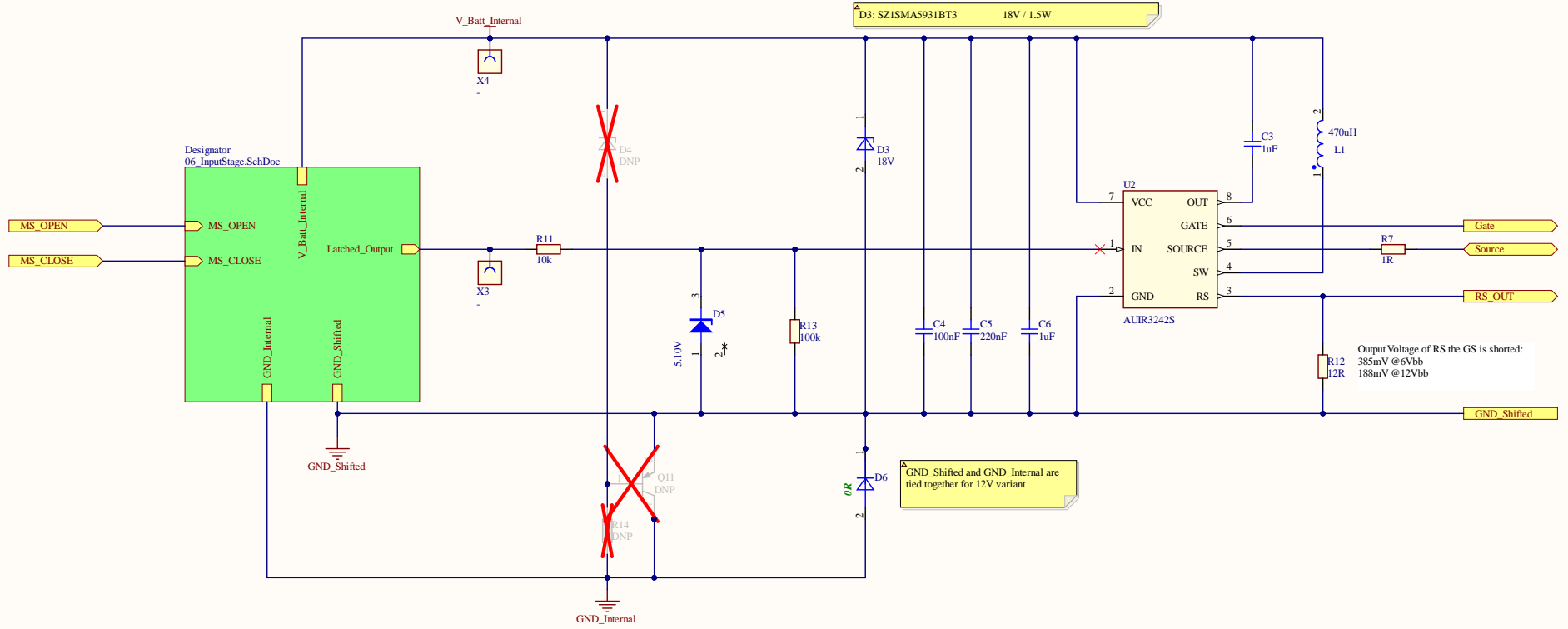
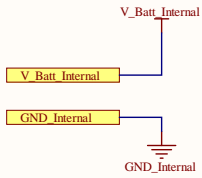

Restricted

Infineon Technologies AG ATV SYS SAE HW Am Campeon 1-15 - 85579 Neubiberg - Germany			
Title Battery Switch 12V			
Variant 12V_Version			Approved _
Size: A3	Document Name: 04_Driver.SchDoc	Rel. KP	Rev. 1.0
Author: KP		SVN Revision: Not in version control	
Date: 23.10.2020 Time: 14:55:09		© Infineon Technologies AG 2014. All Rights Reserved.	
			Sheet 7 of 7

05_Switch.SchDoc

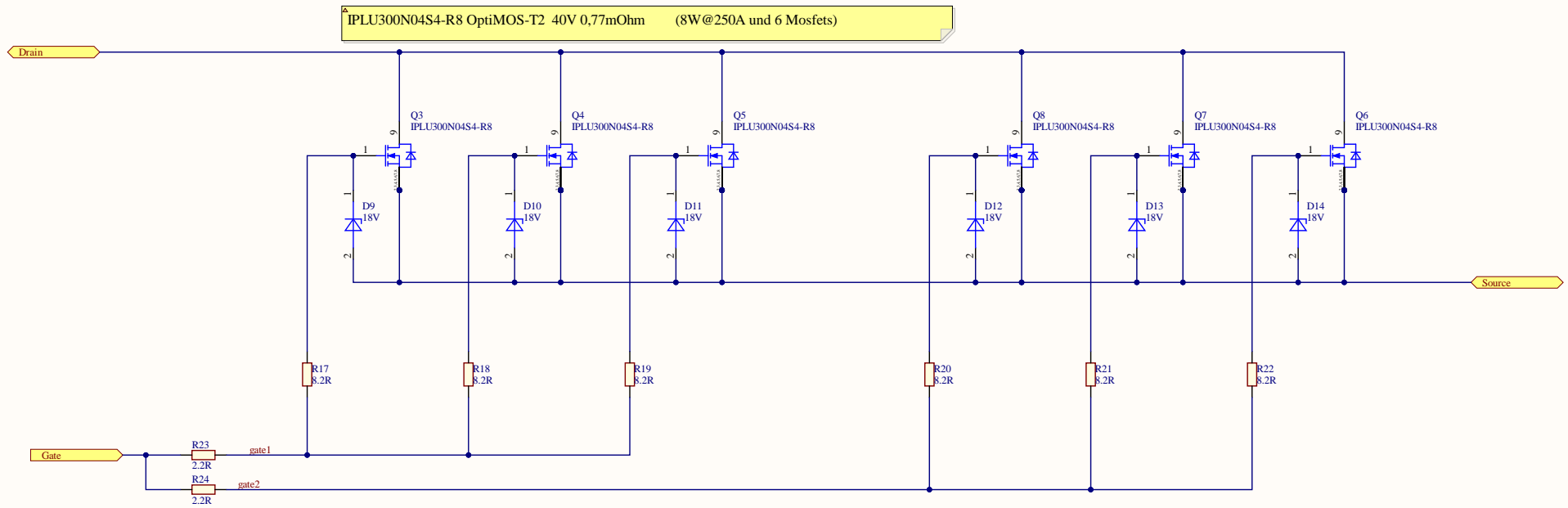

Restricted

		Infineon Technologies AG	
		ATV SYS SAE HW	
		Am Campeon 1-15 - 85579 Neubiberg - Germany	
Title Battery Switch 12V			
Variant 12V_Version			Approved
Size: A3	Document Name 05_Switch.SchDoc		Rel. KP Rev. 1.0
Author: KP			
Date: 23.10.2020 Time: 14:55:09		SVN Revision: Not in version control	
© Infineon Technologies AG 2014. All Rights Reserved. Sheet 7 of 7			

06_InputStage.SchDoc

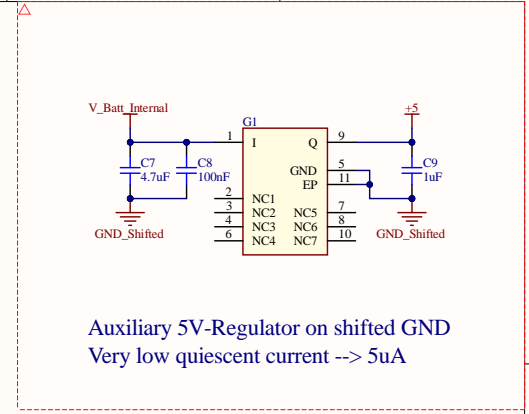
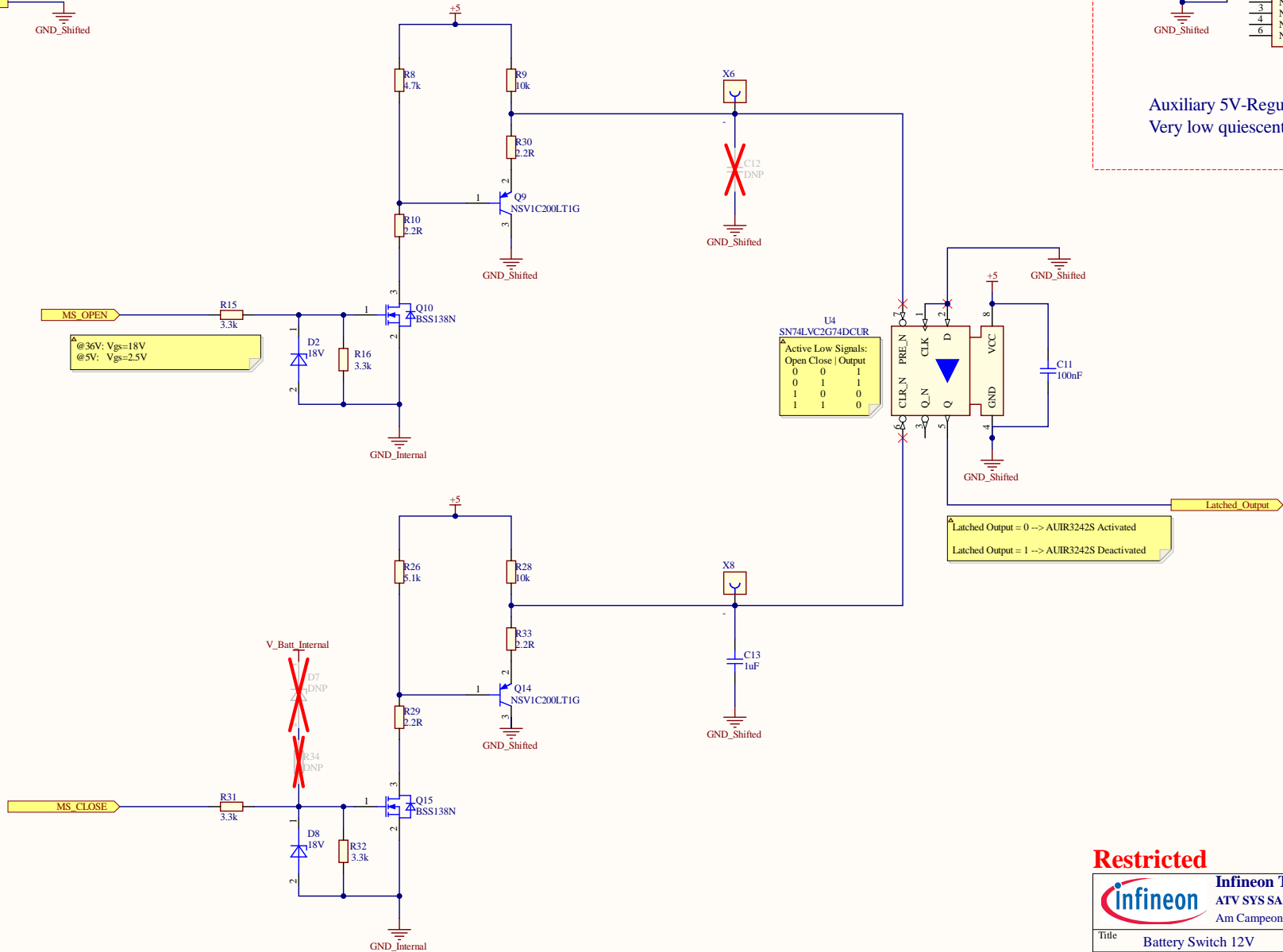
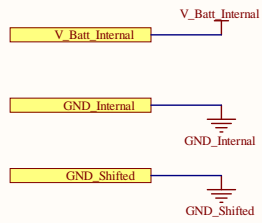

Restricted

Infineon Technologies AG
ATV SYS SAE HW
Am Campeon 1-15 - 85579 Neuburg - Germany

Title: Battery Switch 12V		Approved: _	
Variant: 12V_Version		Rel.:	Rev.:
Size: A3	Document Name: 06_InputStage.SchDoc	KP	1.0
Author: KP		SVN Revision: Not in version control	
Date: 23.10.2020 Time: 14:55:09		© Infineon Technologies AG 2014. All Rights Reserved.	
		Sheet 7 of 7	

Miscellaneous.SchDoc

Documentation Labels

Note:
notnotenote

Polarity
+ -

Fiducial Markers



BOM Report Configuration

Note!
This component is used to define BOM report configuration. If this component is deleted before other components from database are placed in this project, the BOM report configuration gets lost!

Restricted

		Infineon Technologies AG	
		ATV SYS SAE HW	
		Am Campeon 1-15 - 85579 Neubiberg - Germany	
Title		Battery Switch 12V	
Variant		12V_Version	Approved _
Size:	Document Name	Rel.	Rev.
A3	Miscellaneous.SchDoc	KP	1.0
Author: KP			
Date: 23.10.2020 Time: 14:55:10		SVN Revision: Not in version control	
© Infineon Technologies AG 2014. All Rights Reserved.		Sheet of 7	