

Half-bridge buck converter evaluation board using the EiceDRIVER™ 1EDN TDI (Truly Differential Inputs)

Order code: EVAL_HB_BC_1EDN8550B

About this document

Scope and purpose

The 1EDNx550B is the EiceDRIVER™ family of single-channel Low-Side (LS) gate drivers with Truly Differential Inputs (TDI) [1].

The TDI Half-Bridge (HB) Buck-Converter (BC) evaluation board described in this document is designed to show the robustness of the 1EDNx550B to:

- DC offsets between the GND of the driver and the GND of the microcontroller
- AC distortion between the GND of the driver and the GND of the microcontroller.

Intended audience

This document is intended for SMPS designers and engineers interested in:

- understanding the advantages of the driving concept with TDI
- using the 1EDNx550B as a High-Side (HS) driver in Low-Voltage (LV) applications up to 84 V bulk voltage (full-bridge synchronous rectifiers, HB and full-bridge-based brick converters)
- using the 1EDNx550B to solve driving issues in noisy environments characterized by significant parasitic inductance on the ground path [1].

Table of contents

About this document.....	1
Table of contents.....	1
1 HB evaluation board description.....	3
1.1 Concept.....	3
1.2 Design implementation and results	5
1.2.1 1EDNx550B as HS driver.....	5
1.2.2 1EDNx550B robustness to DC GND shifts	7
1.2.3 1EDNx550B robustness to dynamic GND distortions	11
1.2.3.1 Background: driving issues of a standard driver	11
1.2.3.2 Truly differential input 1EDNx550B EiceDRIVER™ as solution	12
1.2.3.3 TDI HB board regulation of the AC GND noise	13
1.2.4 Driving with a standard single-channel LS driver	16
2 Getting started with the hardware	19
2.1 Additional equipment	19
2.2 XMC™ 2Go programming.....	20
2.3 LED explanation	22
2.4 Measurement points	22

Half-bridge buck converter evaluation board using the EiceDRIVER™ 1EDN TDI (Truly Differential Inputs)



Table of contents

3	Addendum.....	24
3.1	Schematic.....	24
3.2	Layout.....	25
3.3	Bill of Materials (BOM).....	26
4	References	29
	Revision history.....	30

Half-bridge buck converter evaluation board using the EiceDRIVER™ 1EDN TDI (Truly Differential Inputs)



HB evaluation board description

1 HB evaluation board description

The evaluation board consists of a 48 V input HB BC including Infineon products as key components:

- EiceDRIVER™ 1EDN TDI (1EDN8550B) with 8 V Undervoltage Lockout (UVLO) as HB LS and HS drivers
- OptiMOS™ 80 V 2.6 mΩ (BSC026N08NS5) in SuperSO8 package as a power MOSFET
- XMC™ 2Go kit including the XMC1100 microcontroller as PWM generator.

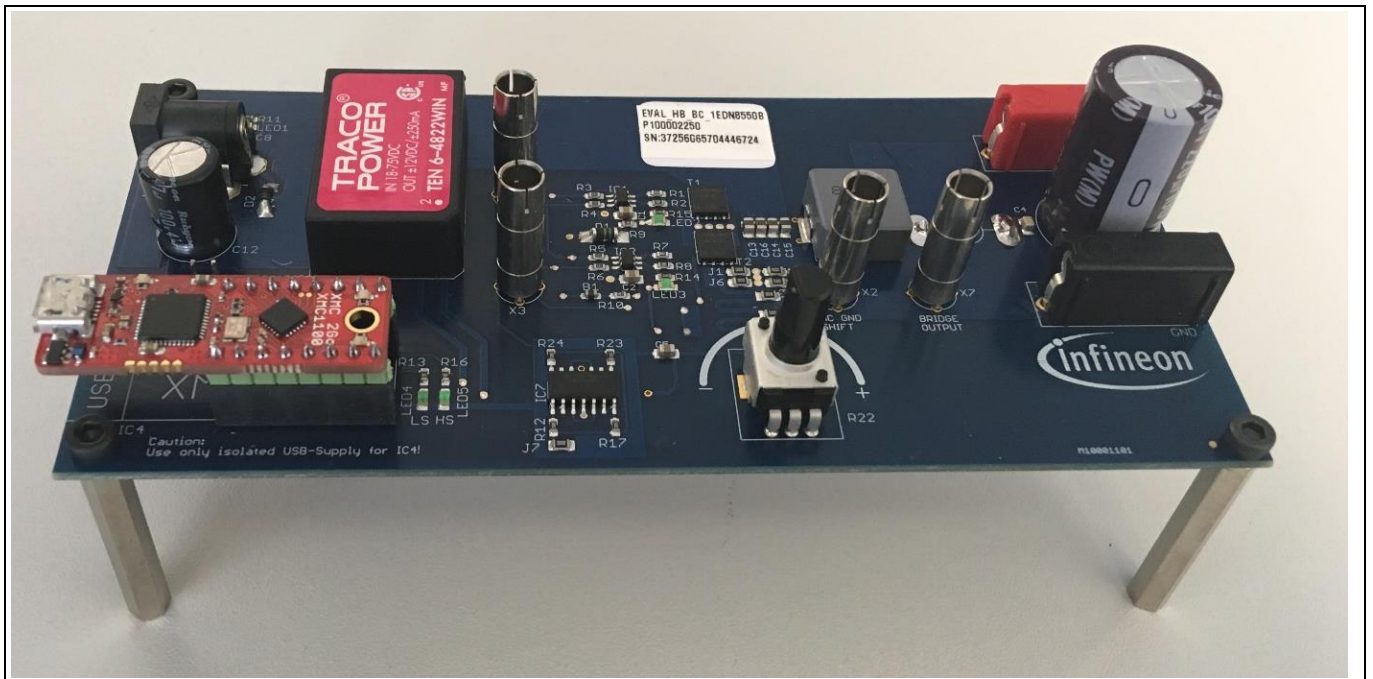

Figure 1 TDI HB BC evaluation board

1.1 Concept

The TDI HB BC evaluation board is designed to evaluate:

1. the 1EDNx550B capability to work as HS driver
2. the 1EDNx550B driver capability to handle DC offsets on the ground potential line
3. the 1EDNx550B driver capability to handle dynamic AC distortions on the ground potential line.

Half-bridge buck converter evaluation board using the EiceDRIVER™ 1EDN TDI (Truly Differential Inputs)



HB evaluation board description

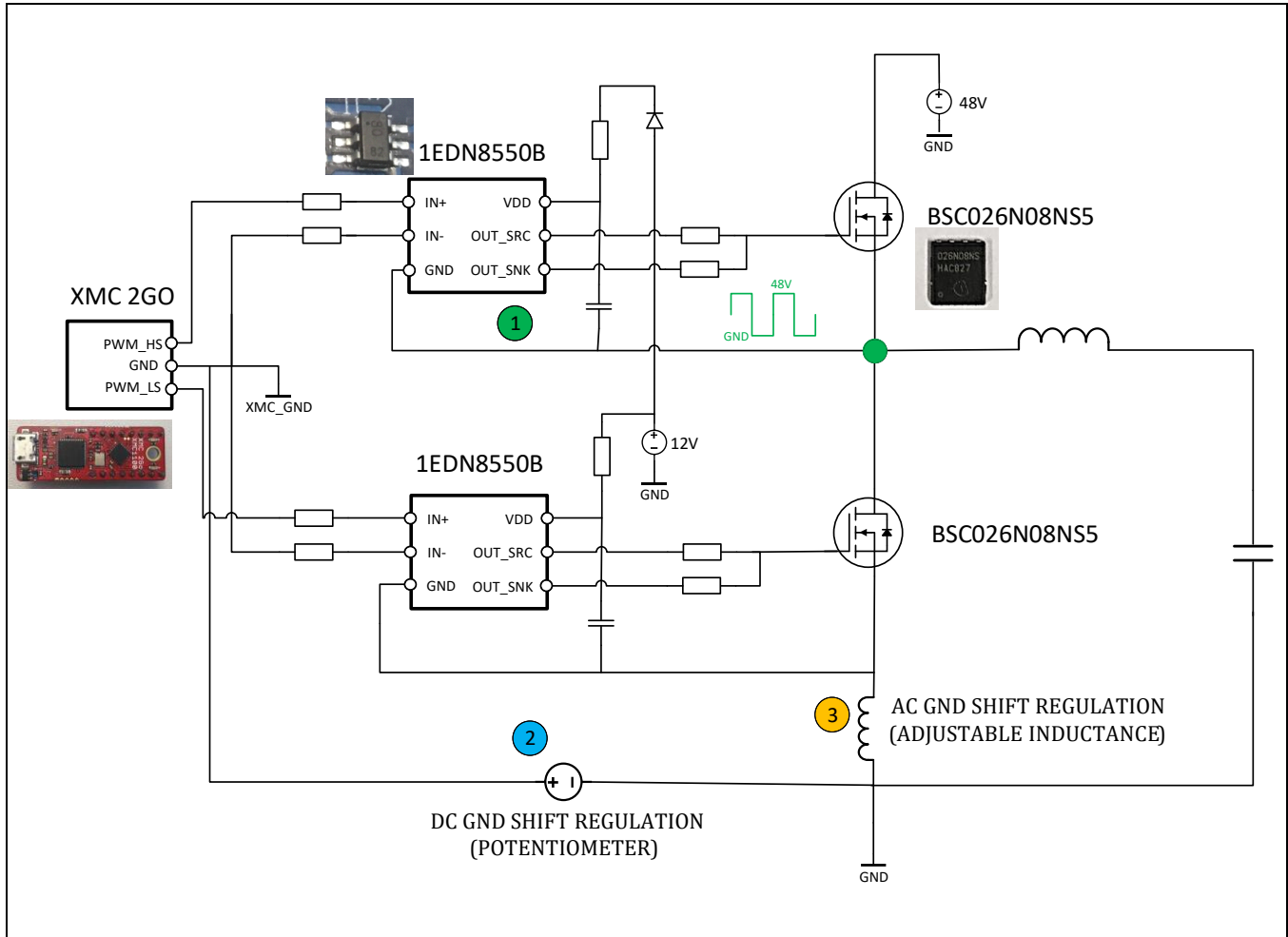

Figure 2 TDI HB BC evaluation board – basic block diagram showing the Infineon products used and the major sections of interest

The block diagram in Figure 2 highlights the three sections involved into the evaluation:

1. The HB design is intended for checking the proper switching of the HS MOSFET using the 1EDN8550B as a HS driver. The comprehension of this point is, in fact, not immediate. Although the 1EDN8550B is a LS driver, its differential input concept makes it able to work with a 48 V floating (referred to the microcontroller GND) ground voltage; it is, then, suitable as a HS driver in the described application.
2. The capability of the 1EDN8550B to properly handle DC GND shifts can be tested by generating an adjustable DC offset between the GND of the microcontroller and the GND of the 1EDN8550B used as LS driver.
3. The parasitic source inductance between the LS MOSFET and the microcontroller influences the amount of noise generated during the switching. The capability of the 1EDN8550B to properly handle AC GND shifts can be tested for significant values of the source inductance.

Paragraph 0 describes these sections in more detail, showing the schematic implementation and the most meaningful results.

Half-bridge buck converter evaluation board using the EiceDRIVER™ 1EDN TDI (Truly Differential Inputs)



HB evaluation board description

1.2 Design implementation and results

This paragraph focuses on the description, in terms of schematic and results, of the three most relevant sections from the 1EDNx550B testing point of view. The measurements are done using the connectors integrated on the board for this purpose, as described in 0.

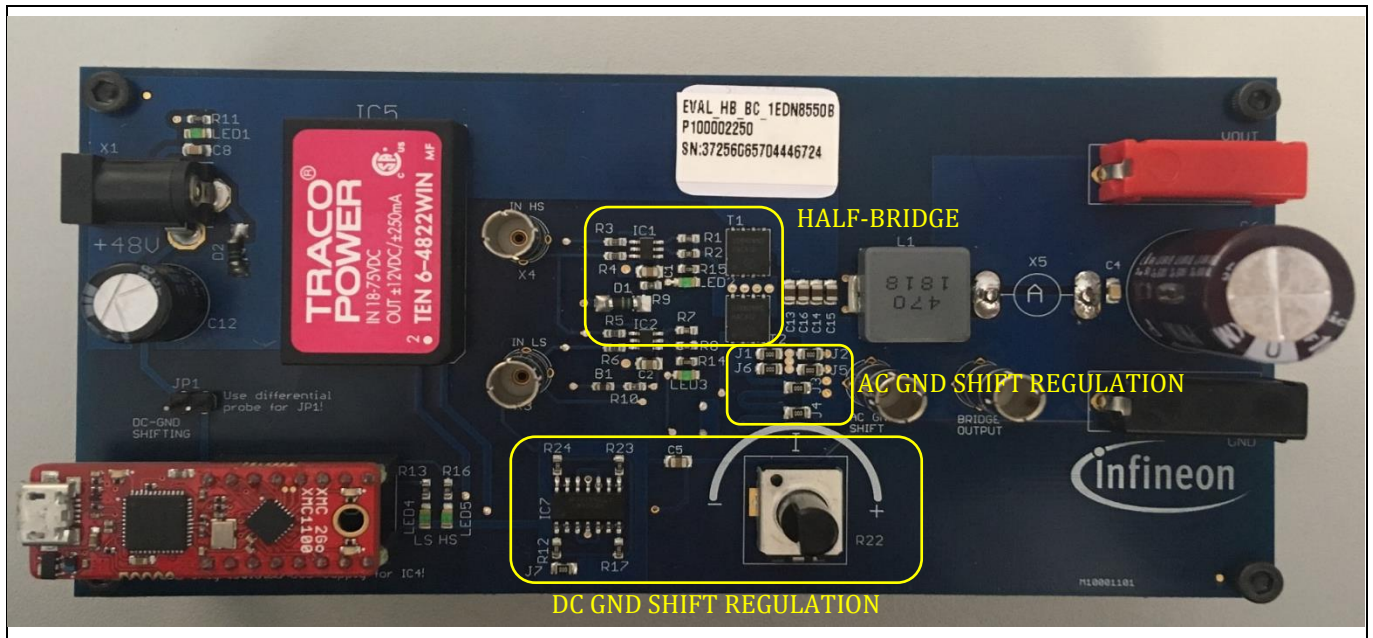

Figure 3 Section of interest for the testing of the 1EDN8550 robustness to GND shifts

1.2.1 1EDNx550B as HS driver

The main intention of the 1EDN TDI HB evaluation board is to show that the 1EDN8550B is suitable as a HS driver.

The three most common HS driving solutions on the market are:

- HB gate drivers, non-isolated solutions realized to drive HB structures and including bootstrap diode and high-level shifter for the proper driving of the HS MOSFET
- non-isolated gate drivers in combination with external transformers for handling the floating ground voltage of the HS MOSFET
- isolated gate drivers.

The 1EDN TDI HB evaluation board instead uses the 1EDN8550B and is the first PCB platform to successfully drive the HS MOSFET through a single-channel LS differential input driver.

Half-bridge buck converter evaluation board using the EiceDRIVER™ 1EDN TDI (Truly Differential Inputs)



HB evaluation board description

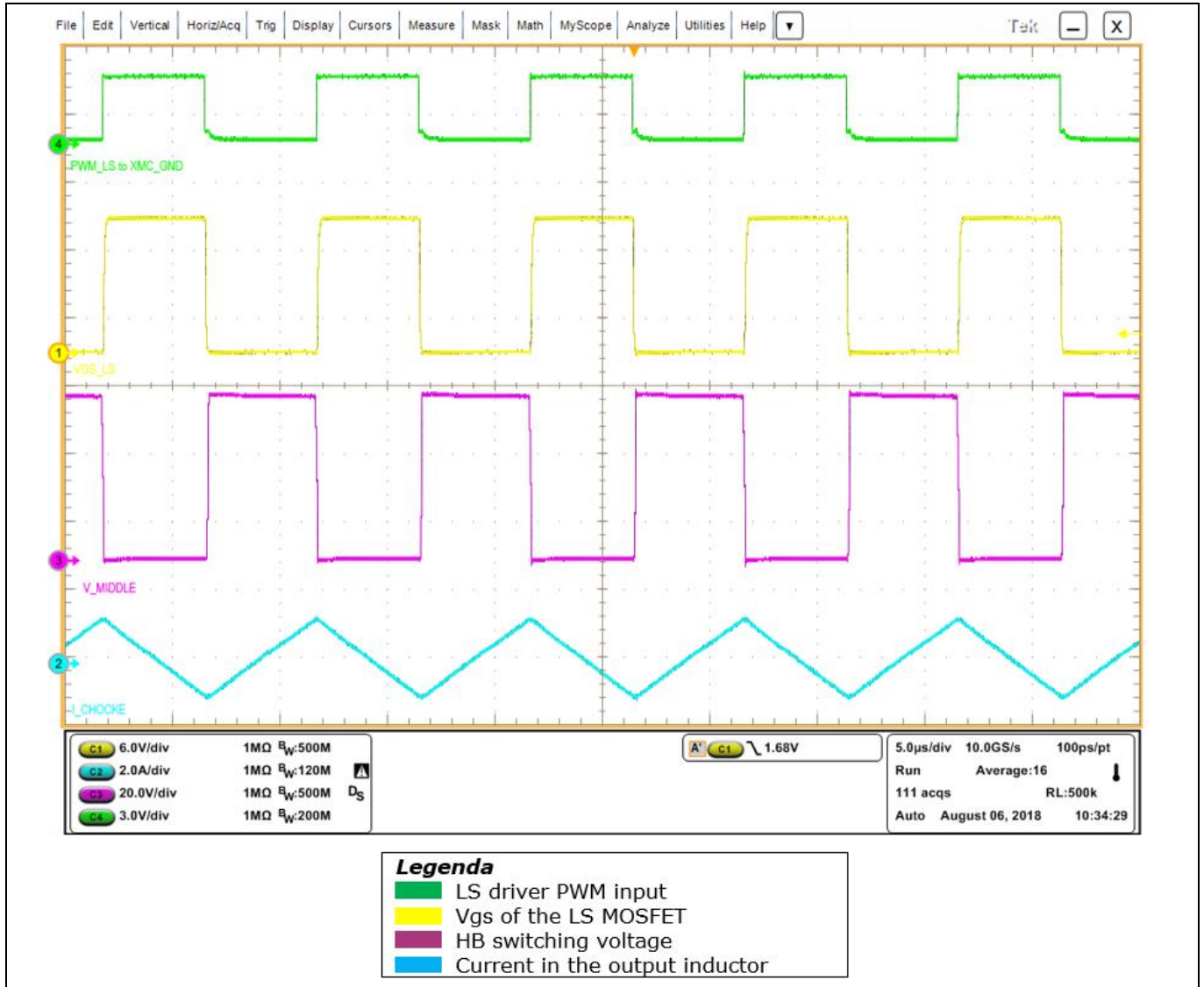

Figure 4 HB waveforms confirming the 1EDN8550B usage as HS driver

The HB switching voltage (the green node in Figure 2) in Figure 4 is the ground voltage of the HS driver. The HB switching node and current trends in Figure 4 show that the HS MOSFET is correctly switched by the 1EDN8550B; this is true even through the 48 V pulse offset (magenta waveform) between the HS driver GND and the microcontroller GND.

In conclusion, the feasibility of using the 1EDN8550B as HS driver is confirmed in this application and is valid in HB designs with bulk voltage up to 84 V.

Compared to the HS driving solutions previously listed, the TDI driving solution requires two 1EDNx550Bs for the LS and HS driving. Besides this, the driver integration in the small SOT-6 package makes it an attractive solution in terms of area taken and reduction of the parasitics. The small package and the usage of two drivers, in fact, enables placement of each 1EDNx550B closer to the related LS or HS MOSFET, optimizing the gate loop. An additional advantage is the competitive price.

1.2.2 1EDNx550B robustness to DC GND shifts

The platform provides the possibility of evaluating the robustness to DC GND shifts of the 1EDN8550B when used as a LS driver. The section in Figure 5 enables regulation of the microcontroller GND voltage, creating an adjustable offset with the LS driver GND (HB GND) in the range [-9.5 V, 11 V].

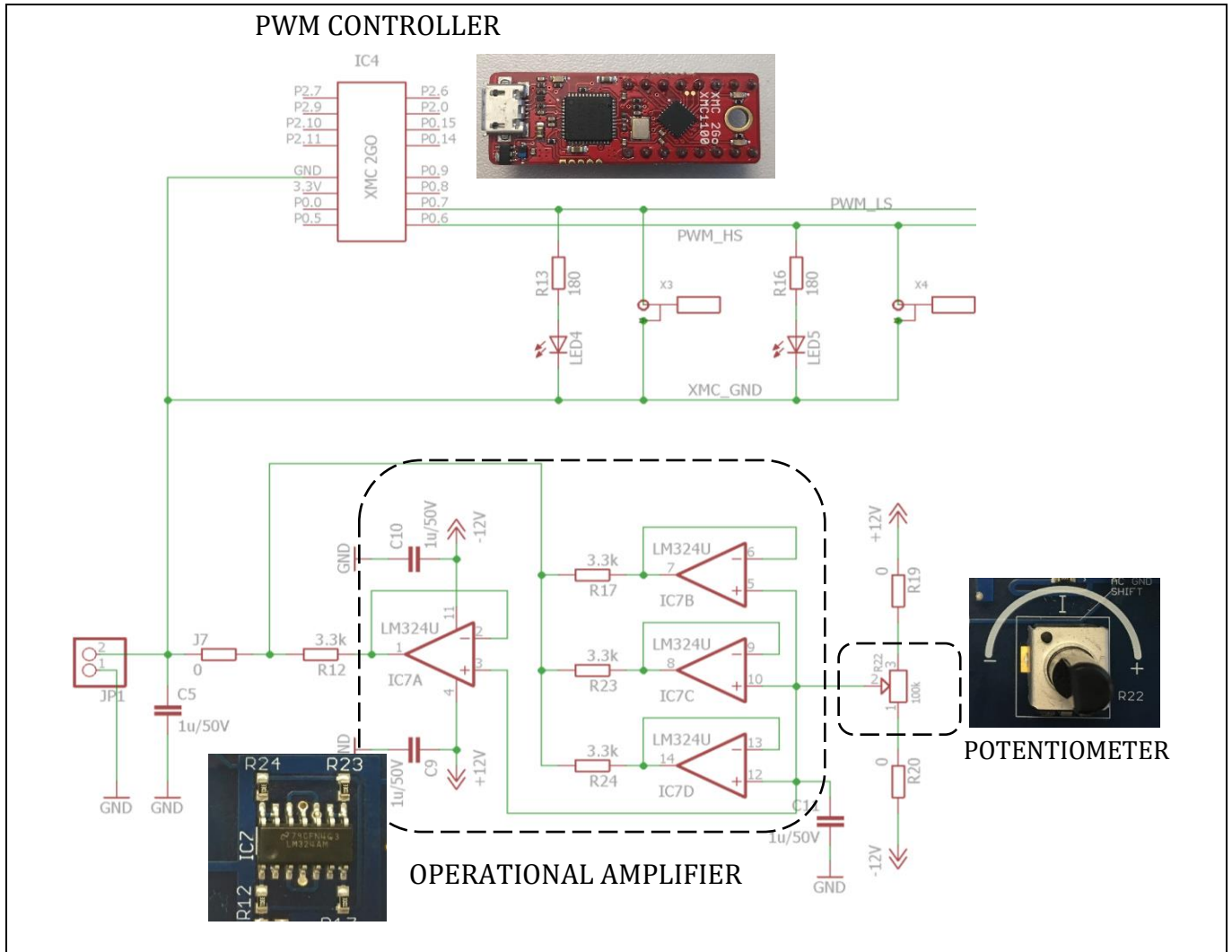

Figure 5 Section for the regulation of the DC offset between the microcontroller GND and the LS driver GND

The DC GND shift is obtained through the trimming of the potentiometer, and can be monitored with a differential voltage probe on the measurement point JP1.

The user can easily change the offset and observe how the waveforms appear. The correct driving with 1EDN8550B is not influenced by the DC GND shift, as shown in Figure 6 for a DC GND shift equal to -9.3 V.

Half-bridge buck converter evaluation board using the EiceDRIVER™ 1EDN TDI (Truly Differential Inputs)



HB evaluation board description

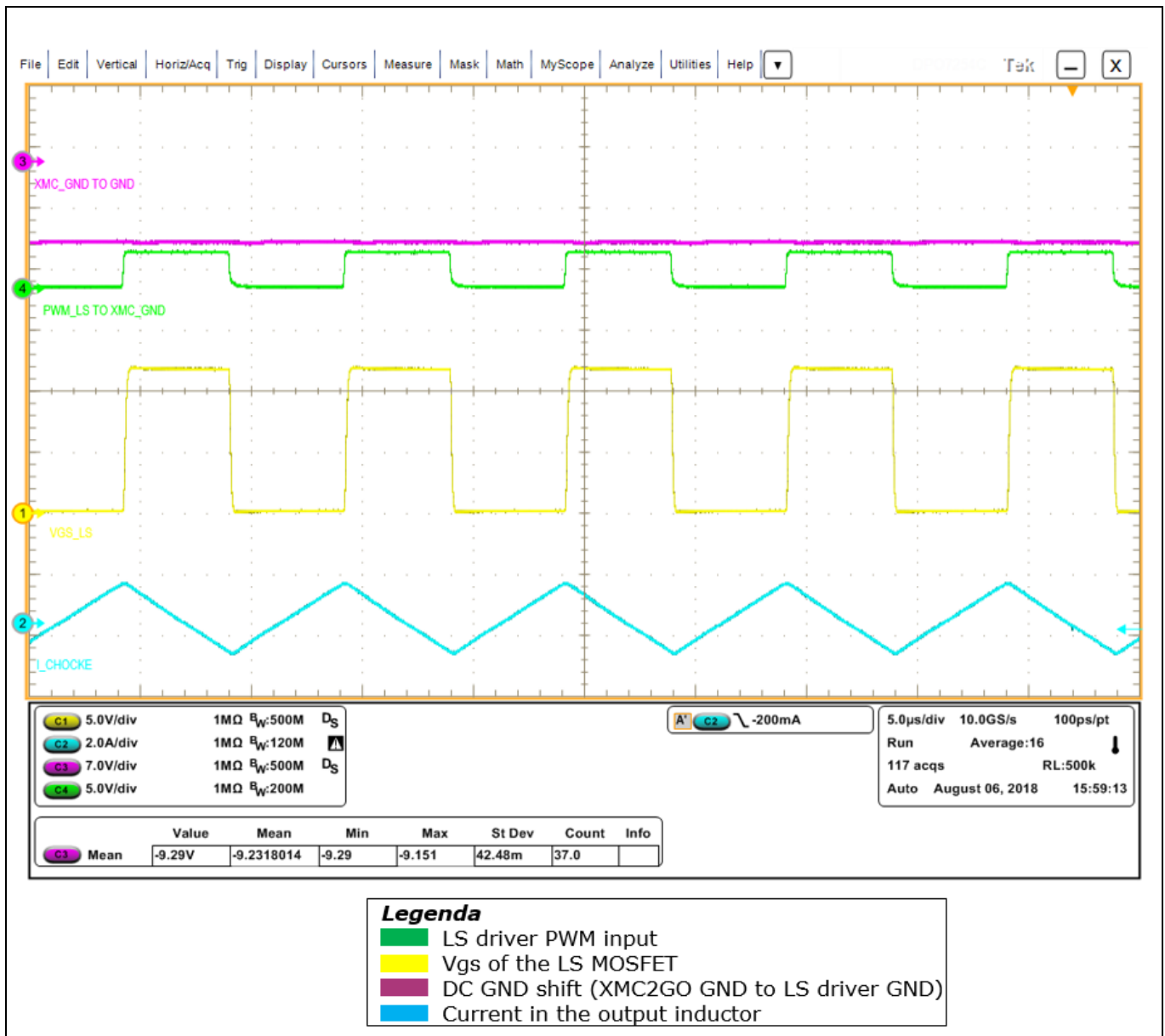

Figure 6 Waveforms confirming the proper 1EDN8550B driving of the LS MOSFET with -9.3 V DC GND offset

With the same DC GND shift, a standard single-channel LS driver does not switch as shown in the results in Figure 7, obtained using the Infineon EiceDRIVER™ 1EDN8511B. It is worth keeping in mind that the high and low voltage levels of the PWM signal are referred to the microcontroller GND and not to the LS driver GND (HB GND). Therefore, for a DC GND shift equal to -9.3 V the driver sees a -6.0 V (3.3 V–9.3 V) PWM signal that is always less than its input threshold voltage; the standard 1EDN8511B is, consequently, in a permanent off-state.

Half-bridge buck converter evaluation board using the EiceDRIVER™ 1EDN TDI (Truly Differential Inputs)



HB evaluation board description

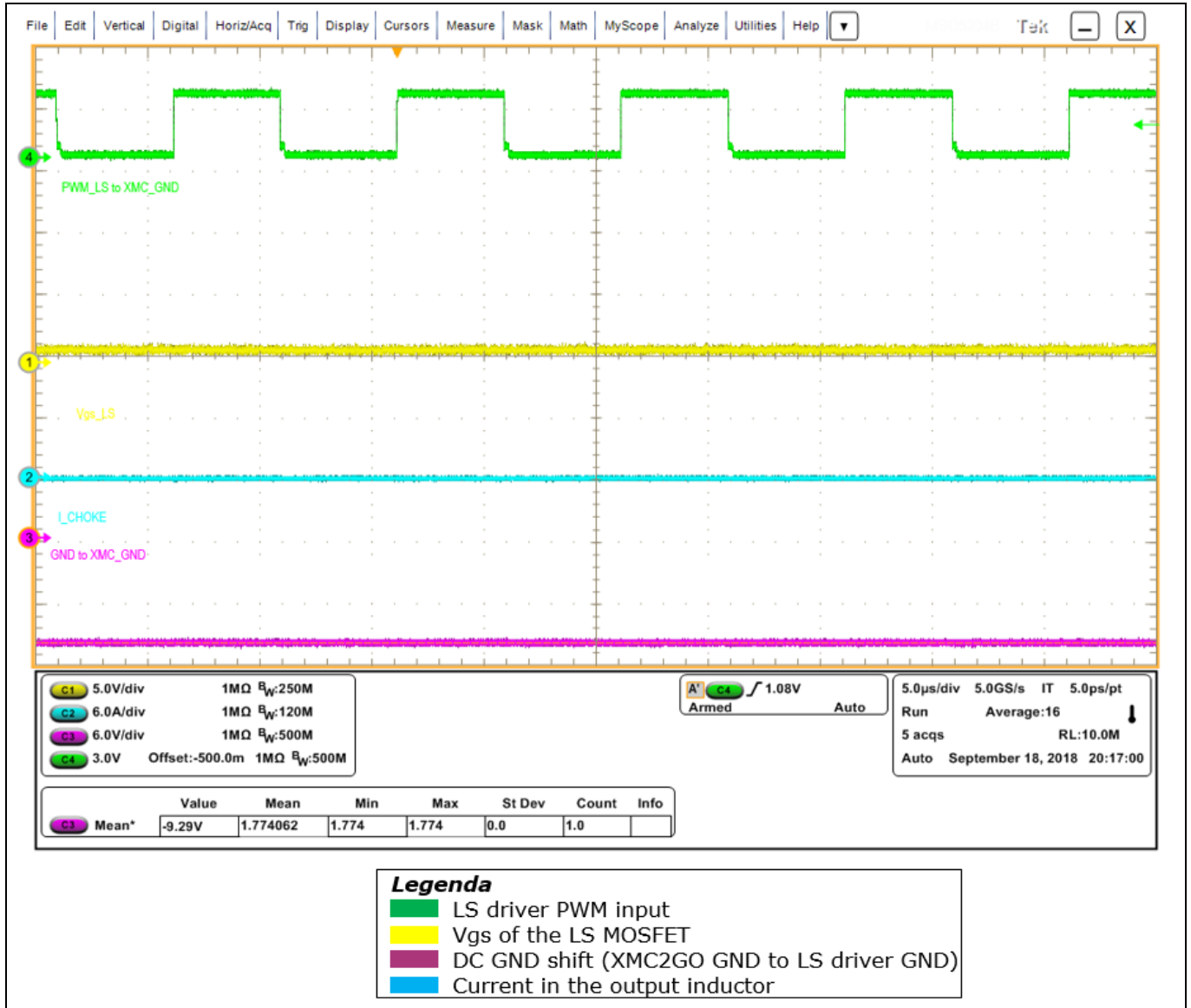

Figure 7 Waveforms showing the weakness of a standard single-channel LS driver to properly work with existing DC GND shifts

The waveforms in Figure 8 are obtained for a DC GND shift equal to 10.93 V using the 1EDN8550B; as shown here, the driver is not influenced.

Half-bridge buck converter evaluation board using the EiceDRIVER™ 1EDN TDI (Truly Differential Inputs)



HB evaluation board description

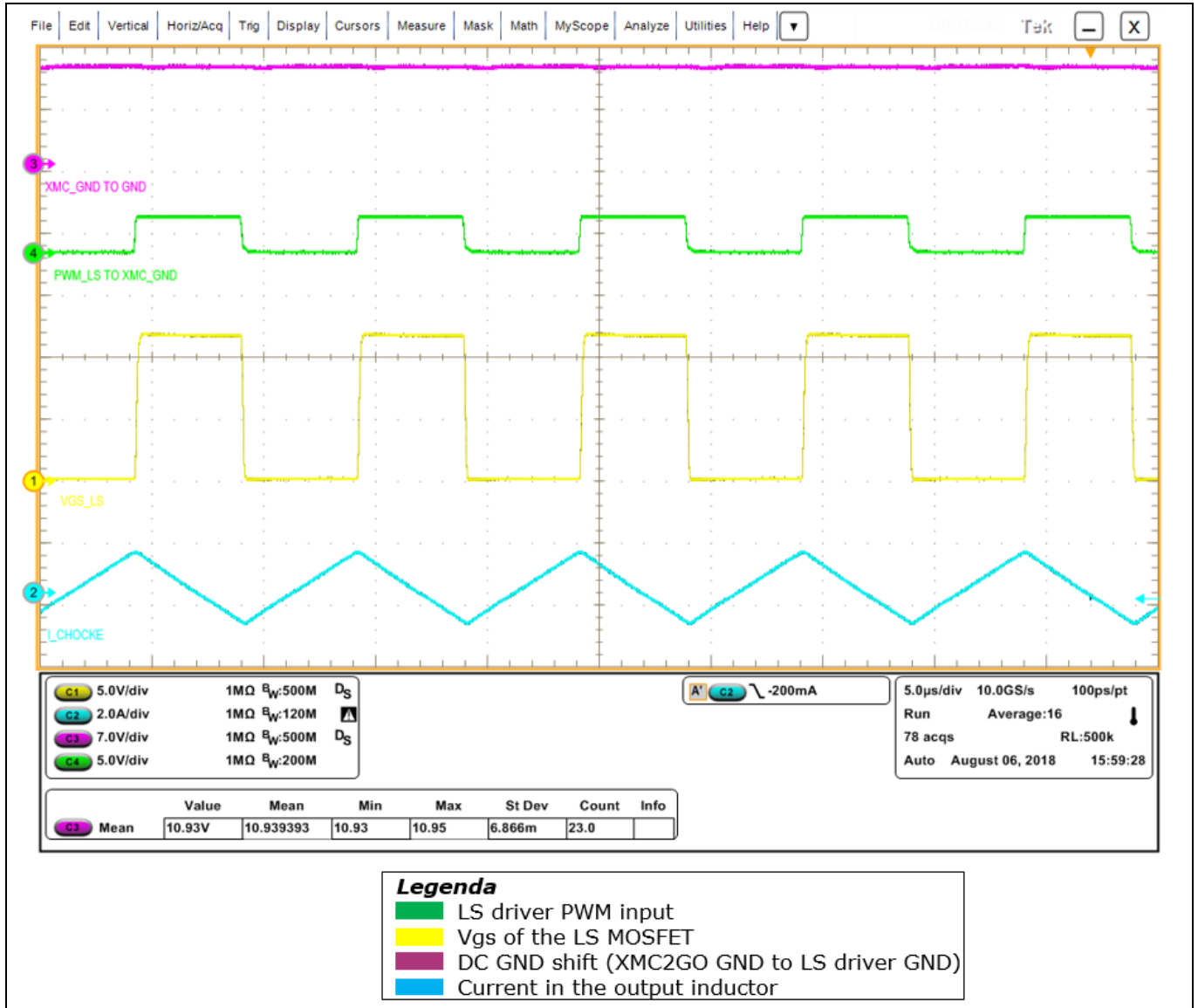

Figure 8 Waveforms confirming the proper 1EDN8550B driving of the LS MOSFET with 10.93 V generated DC GND offset

With the positive DC GND shift in Figure 8, a standard LS driver would be always in the on-state, leading to the destruction of the HB caused by thermal stress on the MOSFETs and shoot-through events.

HB evaluation board description

1.2.3 1EDNx550B robustness to dynamic GND distortions

1.2.3.1 Background: driving issues of a standard driver

The 1EDNx550B concept with truly differential inputs is intended to overcome the common driving problems caused by parasitic GND inductances on the PCB.

For example systems with long distances between the control stage and the MOSFETs side can show a significant parasitic inductance on the ground path. An inductive voltage drop, due to fast current transitions, is generated during the switching of the MOSFETs, which can resonate with the gate-to-source parasitic capacitance of the MOSFET [1].

The AC GND shift between the microcontroller and the driver leads the driver to a misleading interpretation of the input signal and to false triggering. In HB designs this often generates undesirable and destructive shoot-through events.

Evidence is provided by the 1EDN TDI HB board waveforms in Figure 9; they are obtained using a standard LS driver (1EDN8511B) to drive the LS MOSFET in the worst possible condition (described in 1.2.3.3) in terms of AC noise.



Figure 9 Destructive shoot-through event in the TDI HB BC evaluation board with standard single-channel LS driver, in the worst configuration of GND inductance and with 18 Ω load

Half-bridge buck converter evaluation board using the EiceDRIVER™ 1EDN TDI (Truly Differential Inputs)



HB evaluation board description

Considering the 3 V gate threshold of the BSC026N08NS5, the LS driver and the LS MOSFET are continuously turned on and off by the AC noise for approximately 2 μ s. During this time window, the HS MOSFET is on; the repetitive induced shoot-through damages the devices after a few ms.

1.2.3.2 Truly differential input 1EDNx550B EiceDRIVER™ as solution

With a concept based on a differential input stage, the 1EDNx550B provides a driving solution which is independent of the dynamic noise between its GND potential and the microcontroller GND; this is true for switching-induced dynamic shifts up to 150 V.

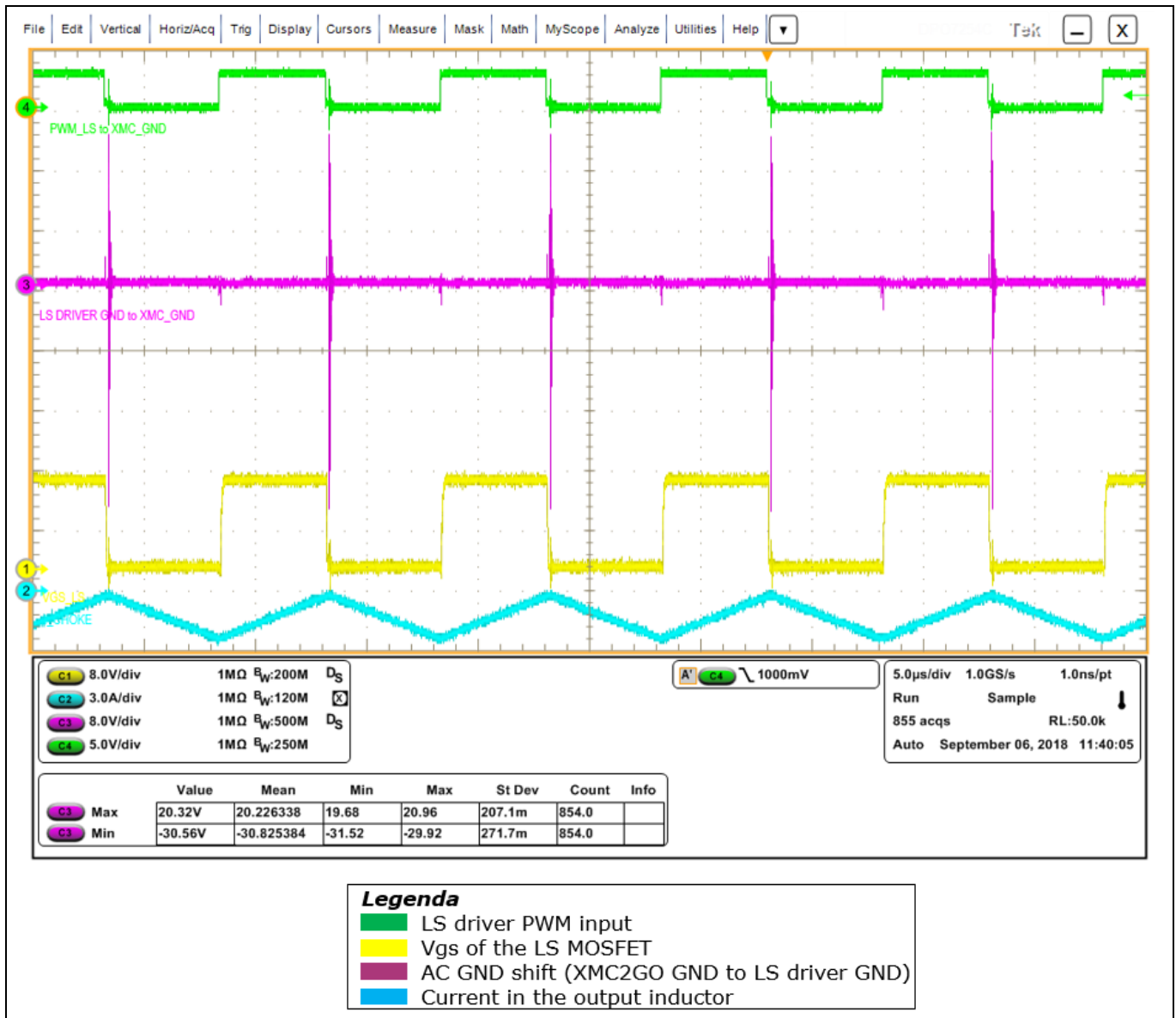

Figure 10 HB BC evaluation board waveforms obtained using the 1EDN8550B as LS driver with 18 Ω load and in the worst configuration of GND inductance showing the TDI driver immunity to AC GND shifts

Figure 10 shows the 1EDN TDI HB board waveforms when the truly differential input 1EDN8550B is used as LS driver; the robustness of the driver is evident and confirmed by the absence of false triggering and shoot-through events.

HB evaluation board description

1.2.3.3 TDI HB board regulation of the AC GND noise

The board provides the possibility of testing 1EDN8550B's robustness to different (in peak value) dynamic GND distortions. The jumpers in Figure 11 enable to regulate the length of the connection between the LS driver GND and the microcontroller GND, and then the value of the GND parasitic inductance. Increasing the GND parasitic inductance increases the dynamic GND oscillation.

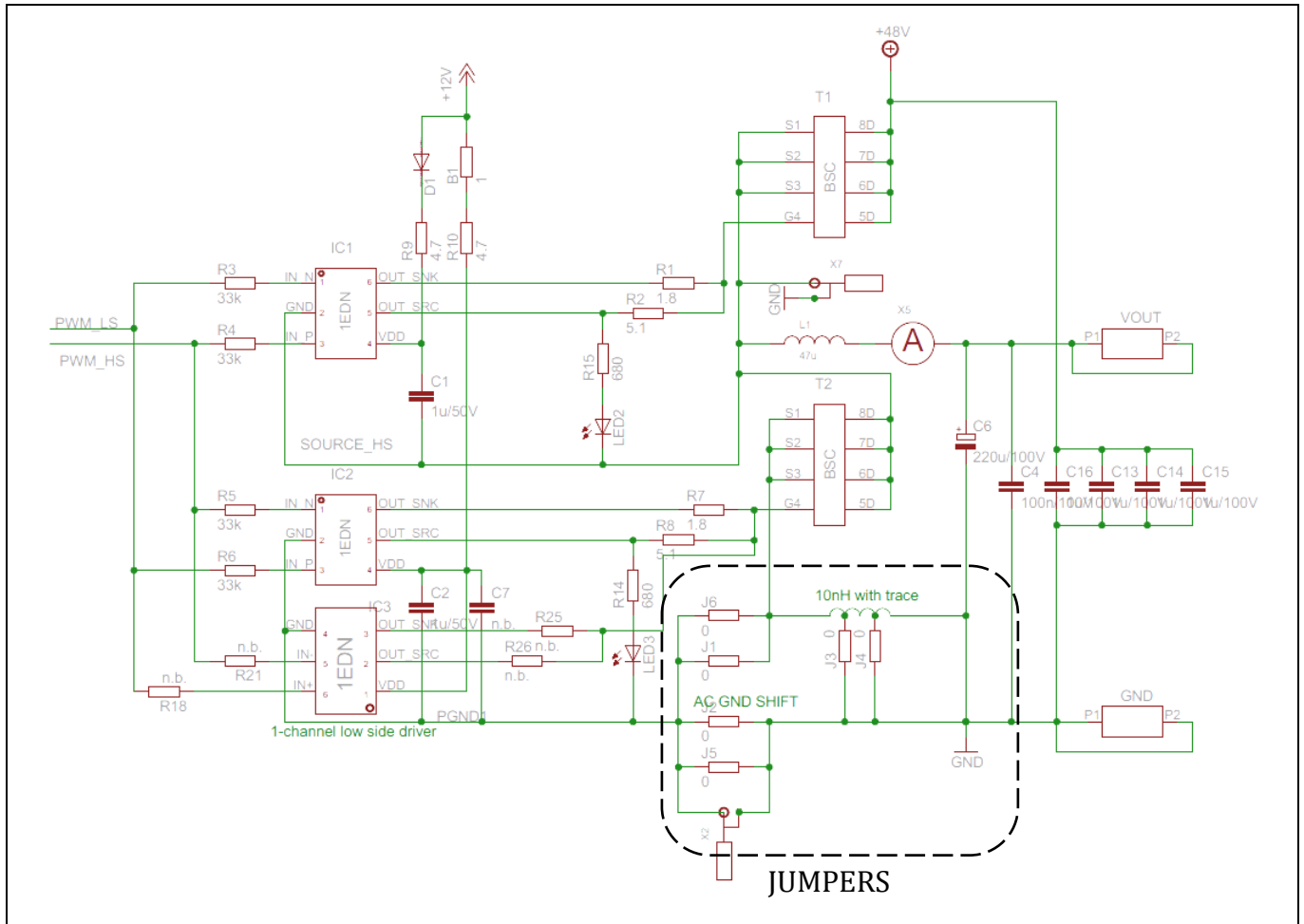

Figure 11 Section for the regulation of the AC noise between the microcontroller GND and the LS driver GND

The board is provided with all the jumpers shorted; among the possible combinations, this configuration is characterized by the lowest parasitic inductances and the lowest dynamic oscillation, as shown in Figure 12. For a deeper understanding, see the different lengths of the available GND paths in the layout view provided in 3.2.

Half-bridge buck converter evaluation board using the EiceDRIVER™ 1EDN TDI (Truly Differential Inputs)



HB evaluation board description

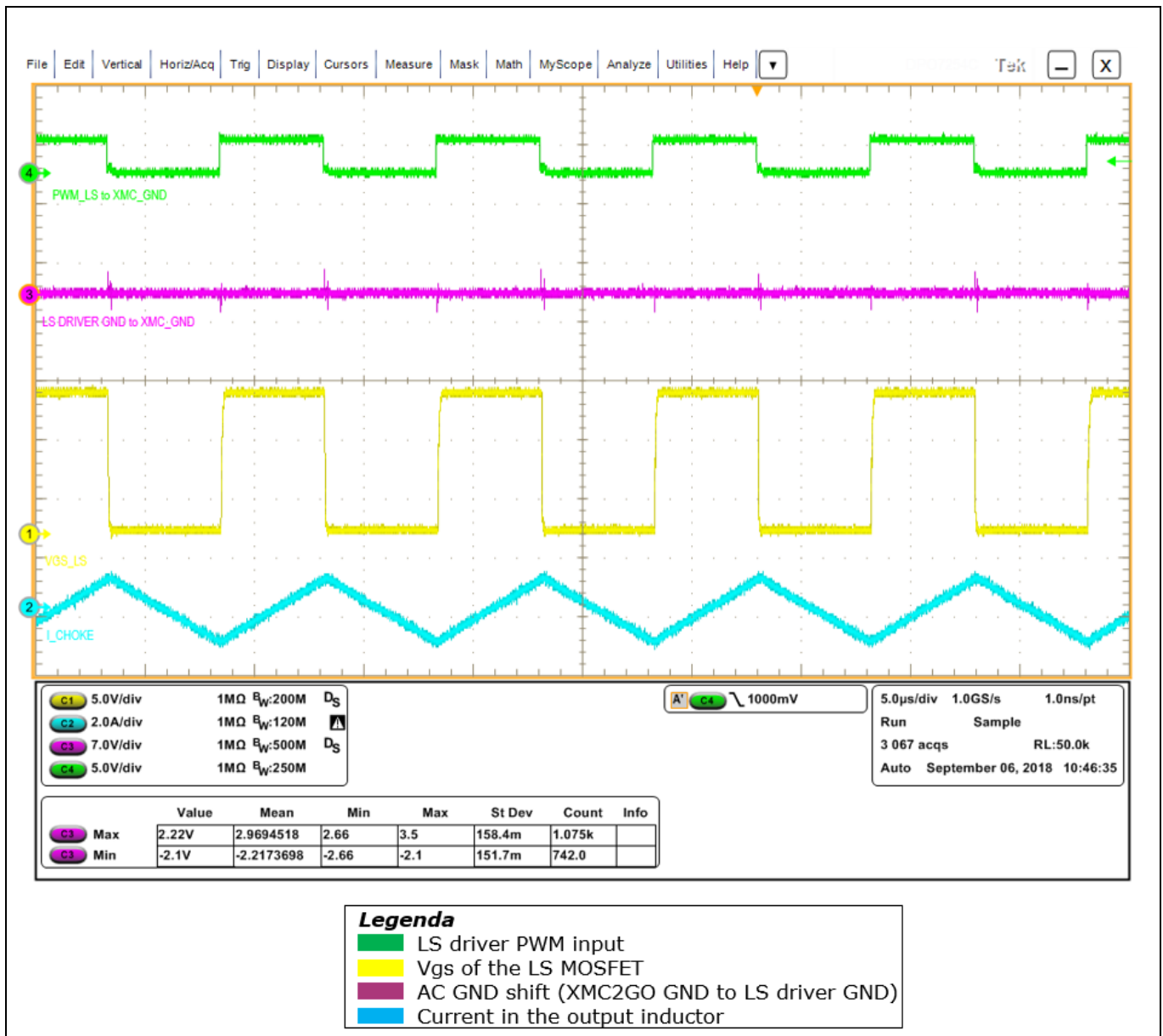

Figure 12 AC noise between the LS driver GND and the microcontroller GND with 18 Ω load in the default configuration for the board with all the jumpers shorted

The oscillations depend on the converter load, and they are bigger at low load because of the high switching current. The waveforms in Figure 12 were captured for 18 Ω load condition.

The waveforms in Figure 9 and Figure 10 are instead related to the worst configuration in terms of AC GND noise, with J1 shorted and the other jumpers opened.

The user can evaluate 1EDN8550B’s robustness in different AC GND-shift scenarios by changing the jumper configuration.

HB evaluation board description

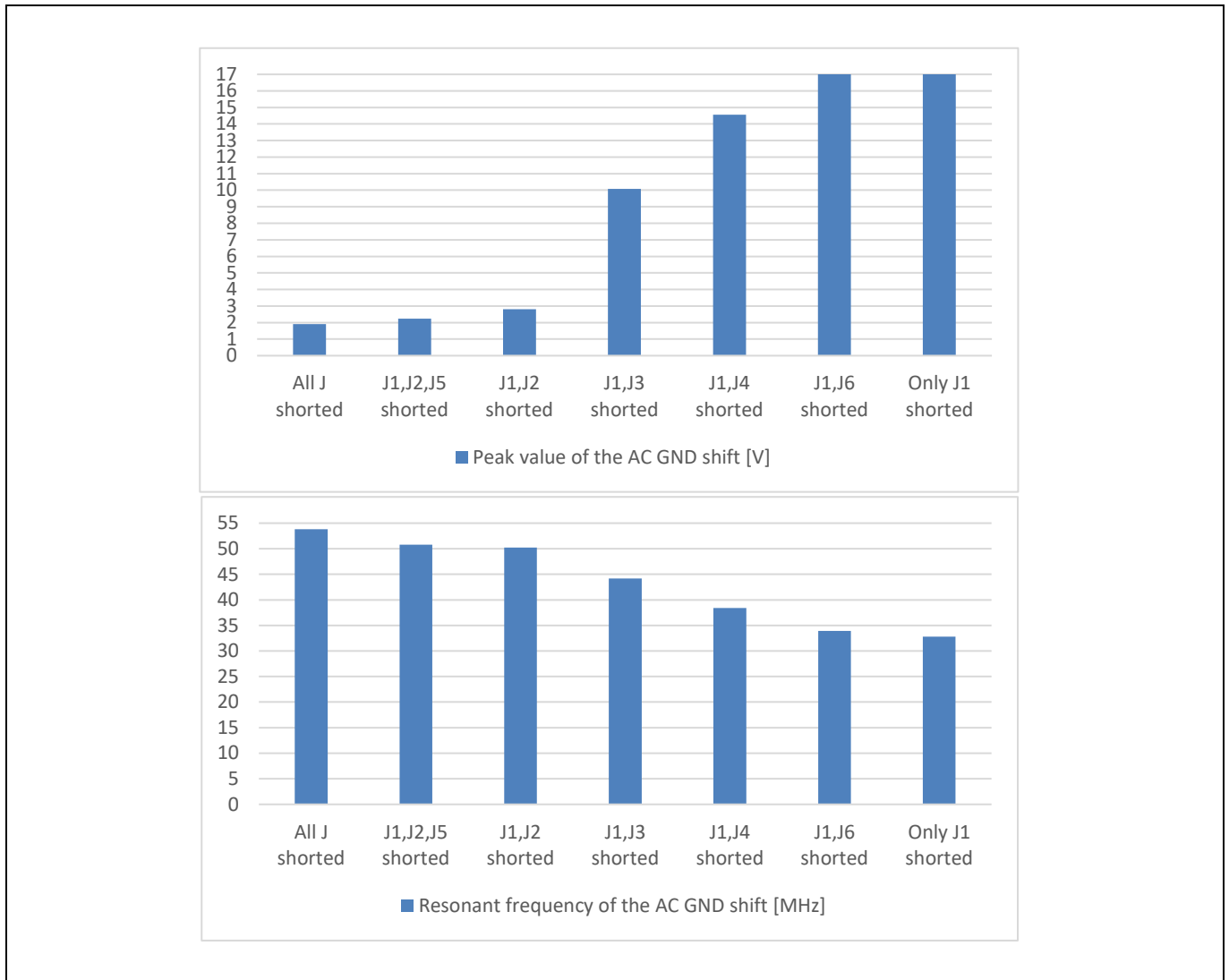

Figure 13 Influence of the jumper configuration on the AC GND-shift peak value and resonant frequency

The graph provides indications for the user who wants to increase or decrease the parasitic source inductance and adjust the resonant frequency and peak value.

1.2.4 Driving with a standard single-channel LS driver

The results of the previous paragraph show that the 1EDN TDI HB evaluation board works well with the 1EDB8550B drivers. However, the user may want to confirm for himself the LS driving failure using a standard driver when DC GND shifts or significant AC GND shifts are present.

For completeness, this paragraph explains how to run the board using a standard driver as LS driver.

As shown in Figure 14, the board already integrates a complementary driving section for the LS MOSFET intended for testing a standard driver.

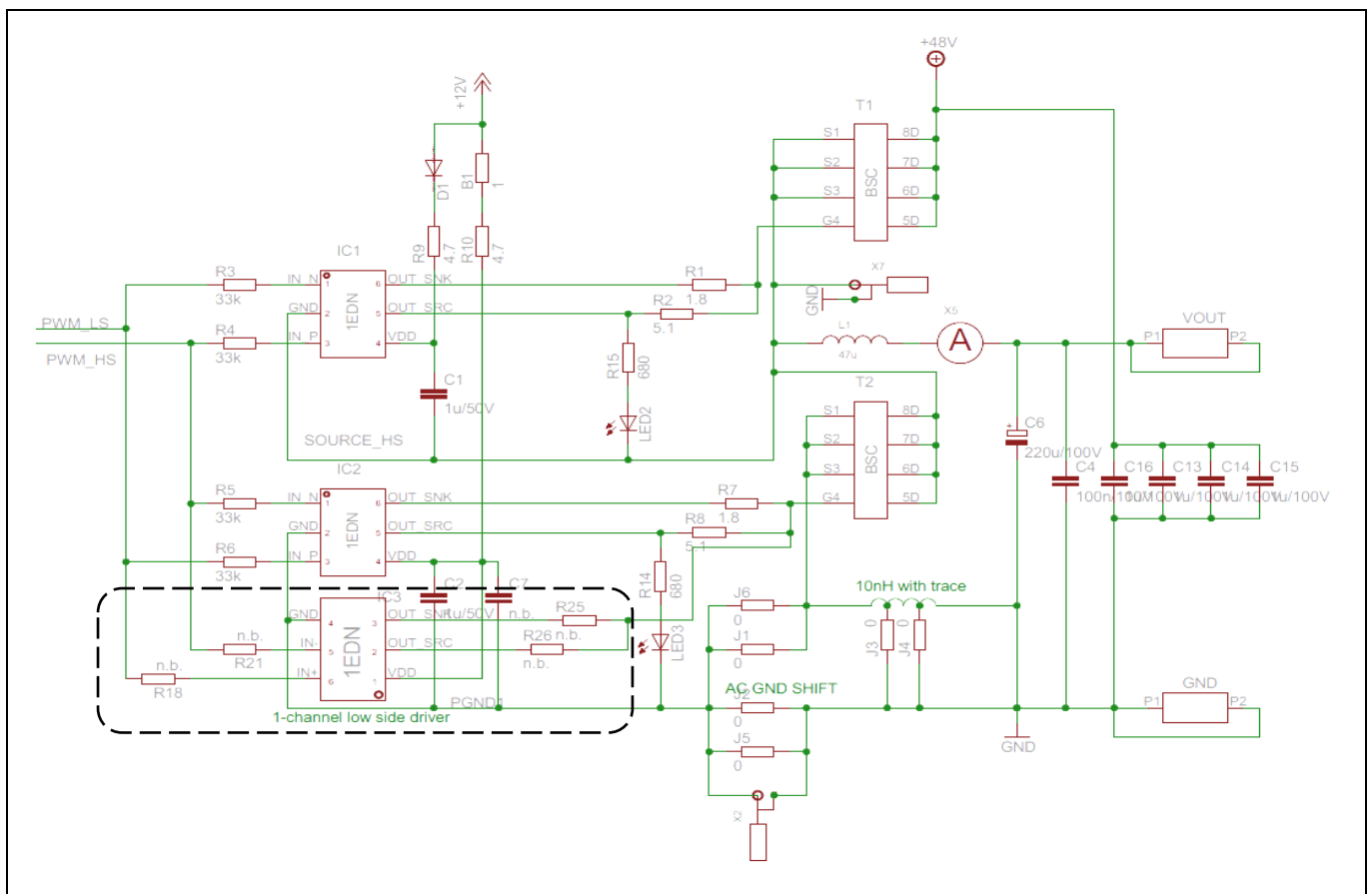

Figure 14 Driving section integrated on the board to drive the LS MOSFET through a standard single-channel driver

This section is integrated on the PCB bottom layer; the related components are originally not populated on the board to enable the user to personalize this driving scheme and choose which single-channel LS driver in the SOT-6 package he wants to test.

Half-bridge buck converter evaluation board using the EiceDRIVER™ 1EDN TDI (Truly Differential Inputs)

HB evaluation board description

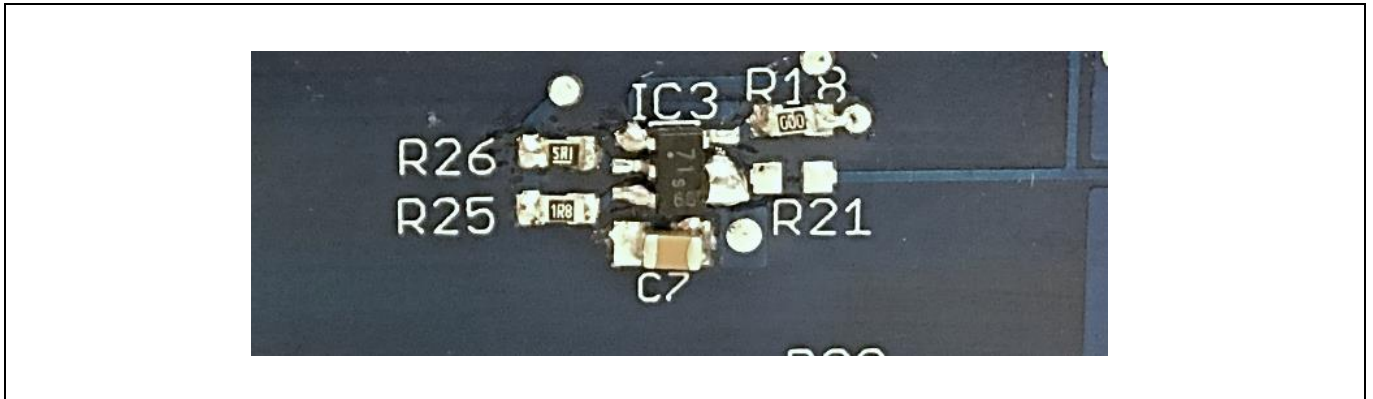

Figure 15 Alternative driving section for the LS MOSFET with the standard single-channel 1EDN8511B soldered for demonstration purposes

Figure 15 shows the LS driving scheme based on Infineon’s single-channel 1EDN8511B; built with the following steps:

- 1 μ F bypass capacitance is soldered in C7 allocation
- 1EDN8511B is soldered in IC3 allocation
- pins IN- and GND are shorted
- input resistor R18 is shorted and R21 is left open
- source and sink gate resistors in 0603 package are soldered respectively in R26 and R25 allocations
- the 1EDN8550B LS driver on the PCB top layer is de-soldered.

In order to start up the board with no failure events, the following steps must be executed:

1. Select the jumper configuration which guarantees the lowest AC GND noise (all the jumpers shorted).
2. Completely rotate the potentiometer counterclockwise to ensure a safe (the standard driver is off) negative DC GND shift.
3. Gradually rotate the potentiometer clockwise, monitoring the DC GND shift, until the driver turns on for a DC GND shift close to 0 V.

Half-bridge buck converter evaluation board using the EiceDRIVER™ 1EDN TDI (Truly Differential Inputs)



HB evaluation board description

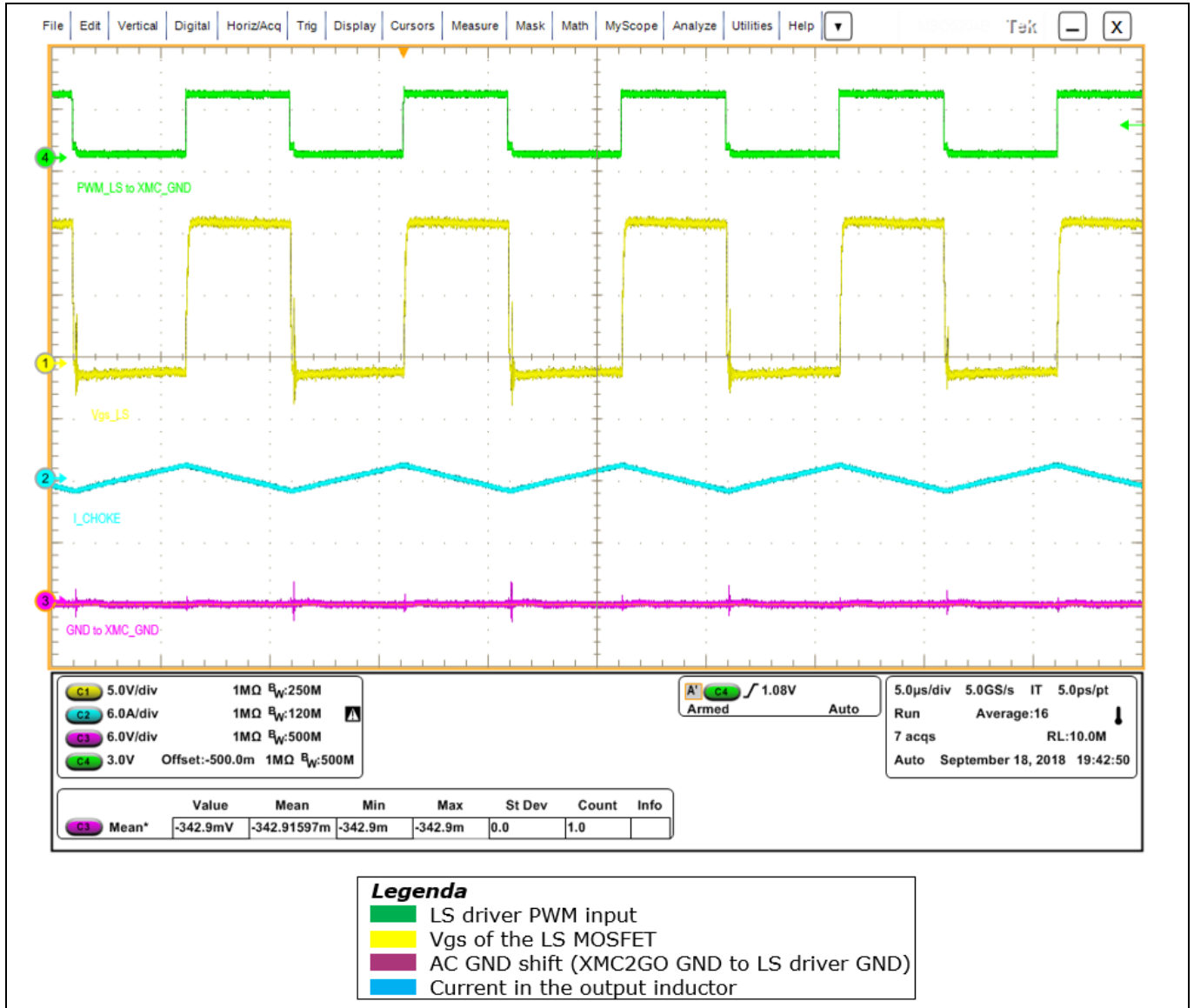

Figure 16 Waveforms showing the board running using the standard single-channel 1EDN8511B as LS driver with 0 V DC GND shift between the microcontroller GND and the LS driver GND

If the user wants to understand on his own the weakness of the standard driver, he can:

- continue to rotate the potentiometer clockwise up to positive DC GND shifts
- change the AC jumper configuration to a more aggressive one.

The user must be aware that, in this case, he is going to damage the HB for thermal stress and shoot-through.

Half-bridge buck converter evaluation board using the EiceDRIVER™ 1EDN TDI (Truly Differential Inputs)



Getting started with the hardware

2 Getting started with the hardware

The intention of this section is to make the user able to power up the board and measure the signals of interest.

2.1 Additional equipment

To make the board operational the user needs the additional instrumentation shown in Table 1.

Table 1 Requirements to make the board operational

Required instrumentation	Purpose	Link
48 V DC power supply	Supply the HB Provide the supply voltage to the drivers	https://www.led-pflanzenlichter.de/mean-well-netzteil-sga60e48-p1j/a-256/ 
Function generator or XMC™ 2Go	Generation of PWM input signals for the drivers	https://www.infineon.com/cms/de/product/evaluation-boards/kit_xmc_2go_xmc1100_v1/

To use the XMC™ 2Go, the user also needs the related components and tools listed in Table 2.

Table 2 Related components

Required instrumentation	Purpose	Link
USB cable for laptop	Program and power up the XMC™ 2Go	
8-pin header with 2.54 mm pitch ¹⁾	Connect the XMC™ 2Go to the board	https://at.rs-online.com/web/c/steckverbinder/leiterplattensteckverbinder/leiterplatten-header/
Installation of DAVE™	XMC™ microcontroller software development	www.infineon.com/dave
Segger's J-Link driver	UART communication for software programming	http://www.segger.com/jlink-software.html 2)

1) Solder the 8-pin headers to the XMC™ 2Go connectors to easily plug the XMC™ 2Go into the board.

2) Refer to XMC™ 2Go manual in [2] for further clarification.

Half-bridge buck converter evaluation board using the EiceDRIVER™ 1EDN TDI (Truly Differential Inputs)



Getting started with the hardware

2.2 XMC™ 2Go programming

A zip file including the DAVE™ code is realized on purpose to generate the PWM signals for the board; it can be downloaded (https://www.infineon.com/dgdl/Infineon-XMC2GO_code_for_the_generation_of_PWM_signals_in_1EDN-TDI_HB_BC-SW-v01_00-EN.zip?fileId=5546d46266f85d630167128887612886) and included as project in DAVE™.

The software in Code Listing 1 generates two PWM signals with 100 kHz frequency, 50 percent duty cycle and 109 ns dead-time.

Code Listing 1

```
while(1U)
{
    // PARAMETERS TO SET: FSW, D, T_D

#define CLOCK_F    64000000.0
#define FSW        100000 // SET the PWM frequency FSW (Hz);
#define FREQ (uint32_t)(CLOCK_F / FSW)
#define D          0.5 // SET the duty cycle D for the PWM LS (Express D in [0,1]
);
#define DUTY (uint32_t)((1-D)*FREQ)
#define T_D        109 // SET the dead time T_D between the PWM LS and HS (Express T_D in
ns)
#define DEAD_TIME (uint32_t)((T_D*CLOCK_F*0.00000001)+0.5)

    PWM_CCU4_0.ccu4_slice_ptr->CRS = DUTY; // Duty cycle (PR-CRS)
    PWM_CCU4_0.ccu4_slice_ptr->PRS = FREQ; //Operating frequency

    PWM_CCU4_1.ccu4_slice_ptr->CRS = DEAD_TIME-5; //Dead time
    PWM_CCU4_1.ccu4_slice_ptr->PRS = DUTY-DEAD_TIME-5; //Duty-Dead time

    PWM_CCU4_0.ccu4_module_ptr->GCSS = PWM_CCU4_0.shadow_txfr_msk |
PWM_CCU4_1.shadow_txfr_msk;
}
}
```

The user can easily change the frequency FSW, the duty cycle D and the dead-time T_D in the code to personalize the HB input signals. In that case they must re-compile the code (build option), connect the XMC™ 2Go to the laptop with the USB cable, and program the XMC™ 2Go (debug option).

The HS and LS PWM signals generated with the settings provided are shown in Figure 16.

Half-bridge buck converter evaluation board using the EiceDRIVER™ 1EDN TDI (Truly Differential Inputs)



Getting started with the hardware

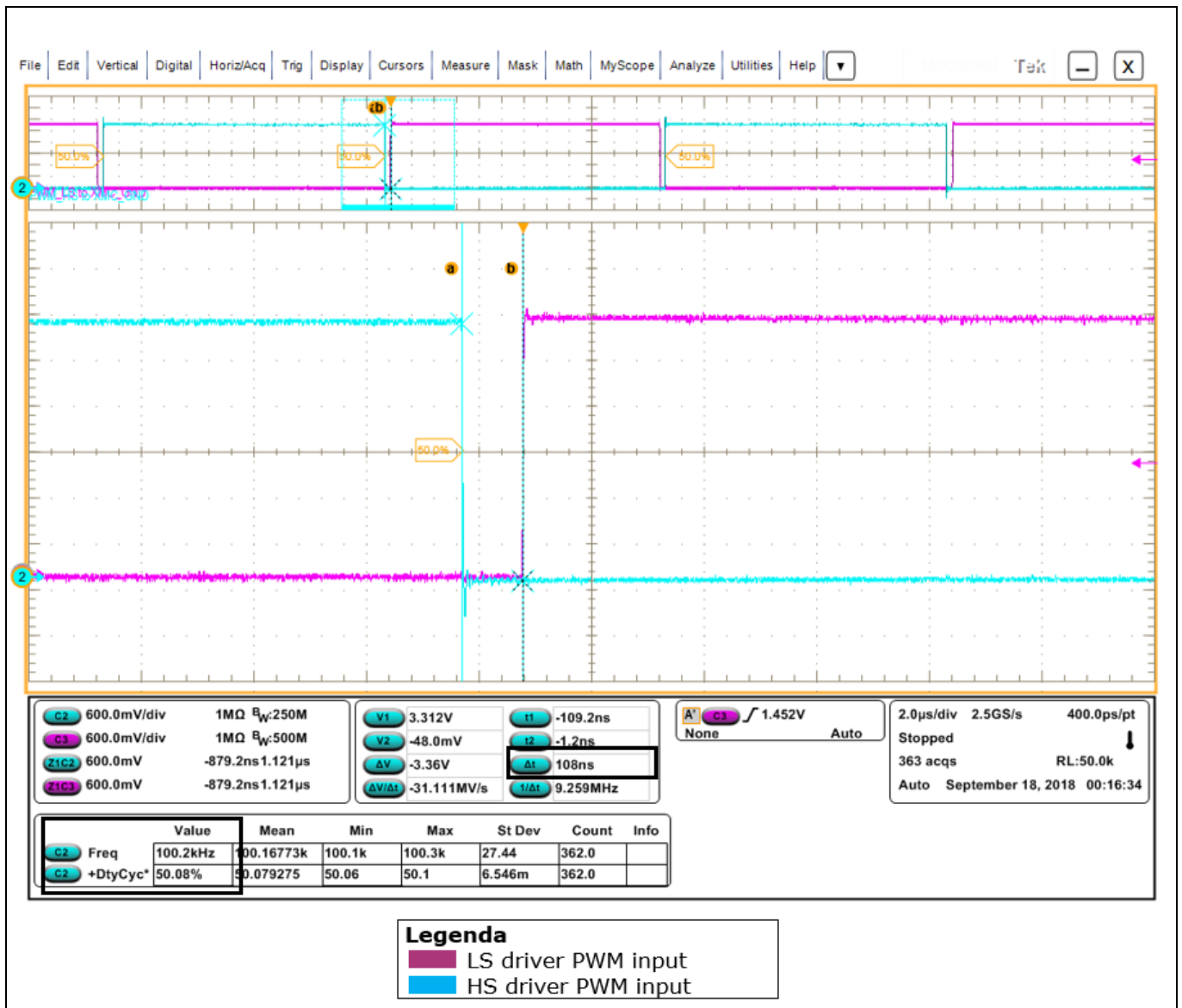

Figure 17 PWM signals generated by the XMC™ 2Go with the code provided in the zip file

The PWM signals are mapped onto the XMC™ 2Go pins shown in Figure 18.

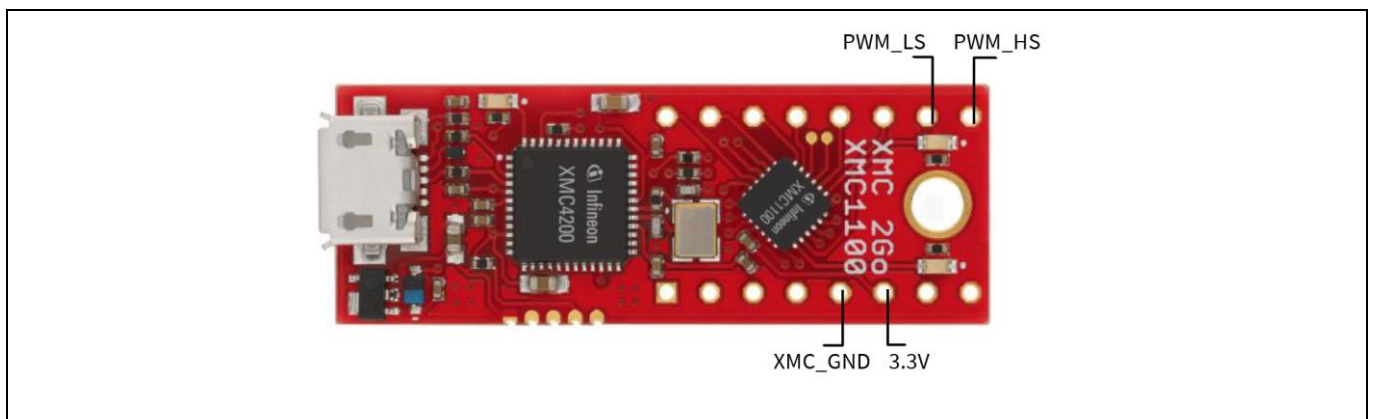

Figure 18 XMC™ 2Go pins mapping for the PWM signals with the code provided in the zip file

Half-bridge buck converter evaluation board using the EiceDRIVER™ 1EDN TDI (Truly Differential Inputs)



Getting started with the hardware

2.3 LED explanation

LEDs are integrated to check the correct behavior of the board and detect errors.

Table 3 LED explanation

LED	Status	Meaning
LED1 on	On	12 V supply voltage for the drivers is correctly generated internally to the board
LED2 on	On	HS driver works properly
LED3 on	On	LS driver works properly
LED4 on	On	LS PWM signal is correctly generated by the XMC™ 2Go
LED5 on	On	HS PWM signal is correctly generated by the XMC™ 2Go
XMC™ 2Go power and debug LED	Blinking	XMC™ 2Go is powered and programmed

2.4 Measurement points

The measurement points shown in Figure 19 enable easy measurement of some signals of interest with a direct plug of the oscilloscope probes.

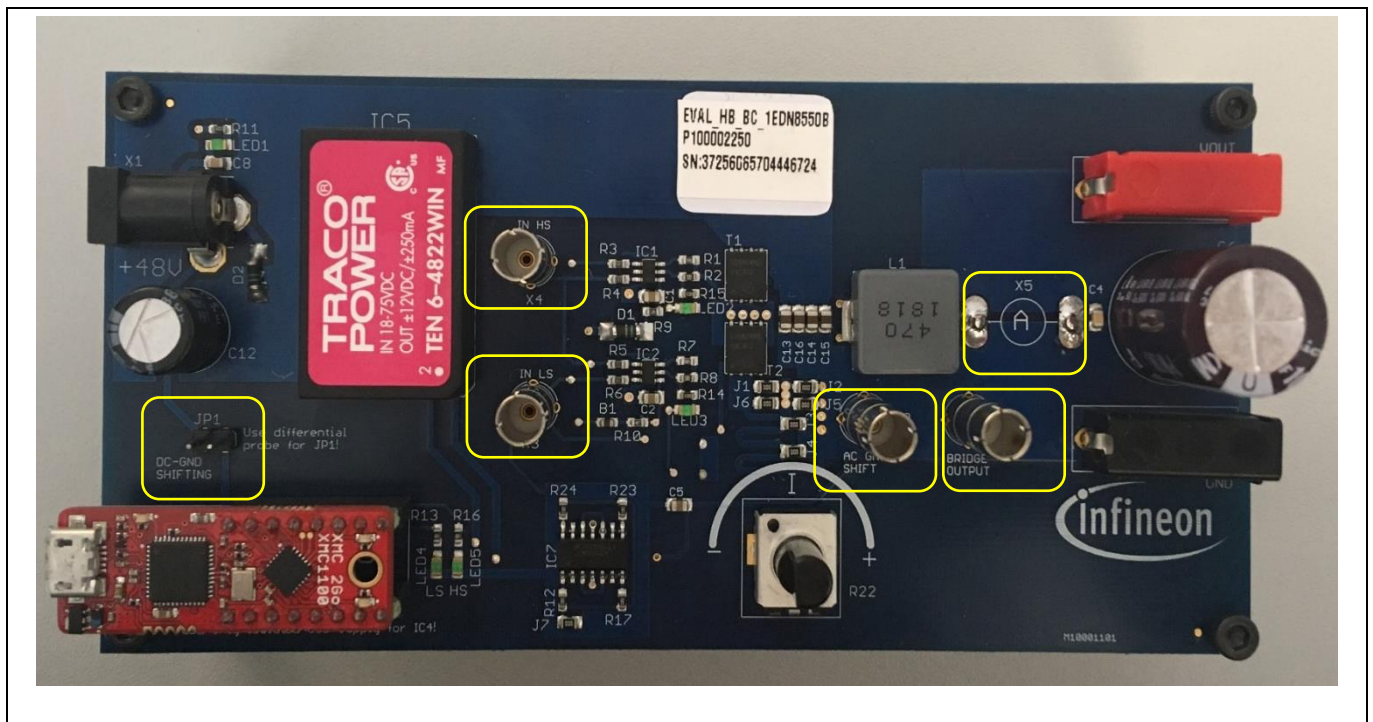

Figure 19 Measurement points on the TDI HB evaluation board

Half-bridge buck converter evaluation board using the EiceDRIVER™ 1EDN TDI (Truly Differential Inputs)



Getting started with the hardware

Table 4 Measurement points

Measurement point	Picture labels	Measurement voltage	Instrumentation
JP1	XMC_GND to GND	DC shift between the XMC™ 2Go ground and the LS driver ground (HB ground)	Differential voltage probe
X2	LS driver GND to XMC_GND	AC shift between the LS driver ground and the XMC™ 2Go ground	Voltage probe
X3	PWM_LS to XMC_GND	PWM signal for the LS driver generated by the XMC™ 2Go (referred to the XMC™ 2Go ground)	Voltage probe
X4	PWM_HS to XMC_GND	PWM signal for the HS driver generated by the XMC™ 2Go (referred to the XMC™ 2Go ground)	Voltage probe
X5	I_CHOKE	Current in the inductor L1	Clamp-on current probes + cable
X7	V_MIDDLE (to GND)	Half-bridge switching voltage (referred to the HB ground)	Voltage probe
V _{OUT} , GND connectors	V_OUTPUT (to GND)	DC voltage on the load (referred to the HB ground)	Multimeter + two banana cables

1) You must solder the cable to X5 contacts.

Some signals listed in the table are not referred to the same ground; if the user wants to measure them simultaneously, they must use an isolated-channel oscilloscope or differential probes.

Half-bridge buck converter evaluation board using the EiceDRIVER™ 1EDN TDI (Truly Differential Inputs)



Addendum

3 Addendum

3.1 Schematic

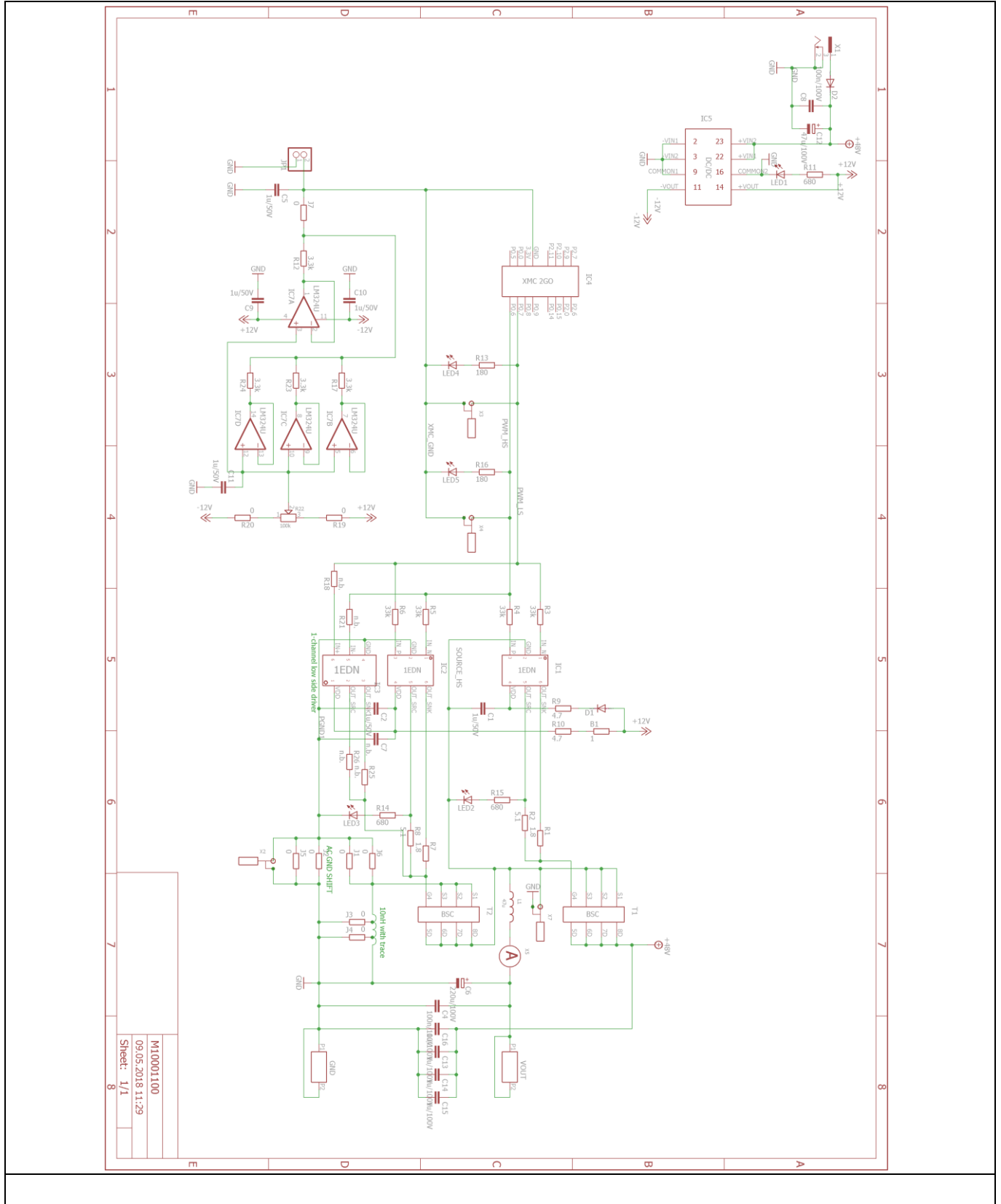

Figure 20 TDI HB BC evaluation board schematic

3.2 Layout

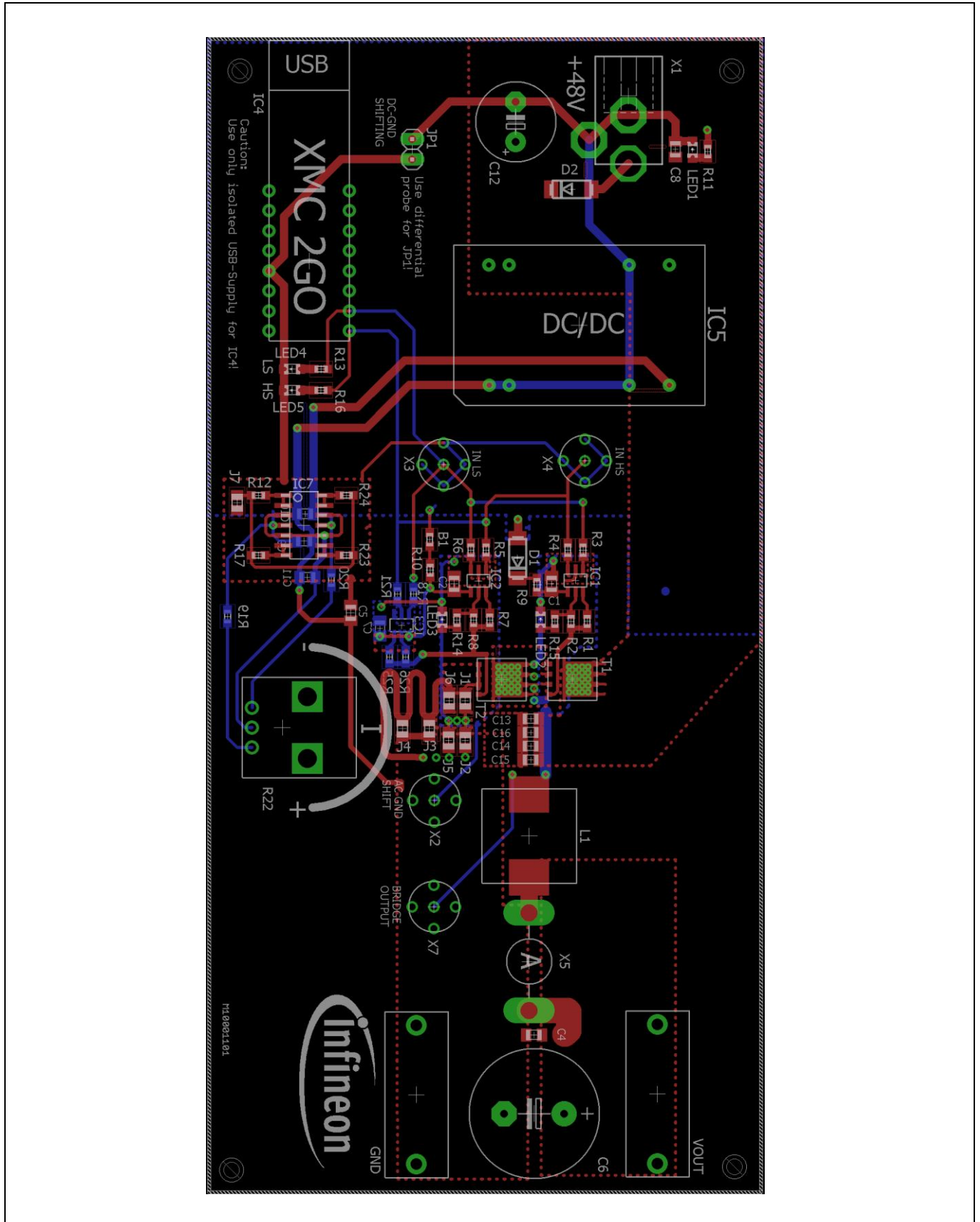

Figure 21 M100011001 HB BC evaluation board schematic

3.3 Bill of Materials (BOM)

Table 5 Bill of Materials

Part	Value	Device	Package	Description	Distributor	Order number
B1	1	R-EU_R0603	R0603	SMD ferrite bead 742792695	RS-Components	669-4024
C1	1 μ /50 V	C-EUC0805K	C0805K	Capacitor, European symbol	Farnell	2676129
C2	1 μ /50 V	C-EUC0805K	C0805K	Capacitor, European symbol	Farnell	2676129
C4	100 n/100 V	C-EUC0805K	C0805K	Capacitor, European symbol	RS-Components	723-5058
C5	1 μ /50 V	C-EUC0805K	C0805K	Capacitor, European symbol	Farnell	2676129
C6	220 μ /100 V	CPOL-EUE7.5-16	E7,5-16	Polarized capacitor, European symbol	RS-Components	715-3050
C7	n.b.	C-EUC0805K	C0805K	Capacitor, European symbol, do not assemble	Farnell	2676129
C8	100 n/100 V	C-EUC0805K	C0805K	Capacitor, European symbol	RS-Components	723-5058
C9	1 μ /50 V	C-EUC0805K	C0805K	Capacitor, European symbol	Farnell	2676129
C10	1 μ /50 V	C-EUC0805K	C0805K	Capacitor, European symbol	Farnell	2676129
C11	1 μ /50 V	C-EUC0805K	C0805K	Capacitor, European symbol	Farnell	2676129
C12	47 μ /100 V	CPOL-EUE5-10.5	E5-10,5	Polarized capacitor, European symbol	RS-Components	703-7380
C13	1 μ /100 V	C-EUC0805K	C0805K	Capacitor, European symbol	RS-Components	915-5263
C14	1 μ /100 V	C-EUC0805K	C0805K	Capacitor, European symbol	RS-Components	915-5263
C15	1 μ /100 V	C-EUC0805K	C0805K	Capacitor, European symbol	RS-Components	915-5263
C16	1 μ /100 V	C-EUC0805K	C0805K	Capacitor, European symbol	RS-Components	915-5263
D1			DO214AA	Diode	RS-Components	710-2774
D2			DO214AA	Diode	RS-Components	710-2774
GND		BANANA_SOCKET	BANANA_SOCKET	4 mm banana socket	RS-Components	738-531
IC1		1EDN8550B	PG-SOT-23-6-1	Infineon TDI driver 1EDN8550B		

Half-bridge buck converter evaluation board using the EiceDRIVER™ 1EDN TDI (Truly Differential Inputs)



Addendum

Part	Value	Device	Package	Description	Distributor	Order number
IC2		1EDN8550B	PG-SOT-23-6-1	Infineon 1EDN TDI driver 1EDN8550B		
IC3	n.b.		PG-SOT-23-6-1	Competitor example: UCC27511, do not assemble	Farnell	2342320
IC4		XMC_2GO	XMC_2GO_P ACKAGE	Two PCB sockets, 2.54 mm, 8 poles each	RS-Components	765-5705
IC5		TEN 6-4822WIN	TEN 6-4822WIN_PA CKAGE	DC/DC converter, 48 V to 12 V	RS-Components	755-3671
IC7		LM324U	SO14	Low-power, precision FET-input operational amplifiers	RS-Components	806-2801
J1	0	R-EU_R0805	R0805	Resistor, European symbol		
J2	0	R-EU_R0805	R0805	Resistor, European symbol		
J3	0	R-EU_R0805	R0805	Resistor, European symbol		
J4	0	R-EU_R0805	R0805	Resistor, European symbol		
J5	0	R-EU_R0805	R0805	Resistor, European symbol		
J6	0	R-EU_R0805	R0805	Resistor, European symbol		
J7	0	R-EU_R0805	R0805	Resistor, European symbol		
JP1		PINHD-1X2	1X02	Pin header	RS-Components	251-8086
L1	47 μ	SMD_1365	1365	Inductor	Distrelec	300-26-111
LED 1		LEDCHIPLED_0805	CHIPLED_0805	Green LED	RS-Components	654-5773
LED 2		LEDCHIPLED_0805	CHIPLED_0805	Green LED	RS-Components	654-5773
LED 3		LEDCHIPLED_0805	CHIPLED_0805	Green LED	RS-Components	654-5773
LED 4		LEDCHIPLED_0805	CHIPLED_0805	Green LED	RS-Components	654-5773
LED 5		LEDCHIPLED_0805	CHIPLED_0805	Green LED	RS-Components	654-5773
R1	1R8	R-EU_R0603	R0603	Resistor, European symbol		
R2	5R1	R-EU_R0603	R0603	Resistor, European symbol		
R3	33 k	R-EU_R0603	R0603	Resistor, European symbol		
R4	33 k	R-EU_R0603	R0603	Resistor, European symbol		
R5	33 k	R-EU_R0603	R0603	Resistor, European symbol		
R6	33 k	R-EU_R0603	R0603	Resistor, European symbol		
R7	1R8	R-EU_R0603	R0603	Resistor, European symbol		
R8	5R1	R-EU_R0603	R0603	Resistor, European symbol		

Half-bridge buck converter evaluation board using the EiceDRIVER™ 1EDN TDI (Truly Differential Inputs)



Addendum

Part	Value	Device	Package	Description	Distributor	Order number
R9	4.7	R-EU_R0603	R0603	Resistor, European symbol		
R10	4.7	R-EU_R0603	R0603	Resistor, European symbol		
R11	680	R-EU_R0603	R0603	Resistor, European symbol		
R12	3.3 k	R-EU_R0603	R0603	Resistor, European symbol		
R13	180	R-EU_R0603	R0603	Resistor, European symbol		
R14	680	R-EU_R0603	R0603	Resistor, European symbol		
R15	680	R-EU_R0603	R0603	Resistor, European symbol		
R16	180	R-EU_R0603	R0603	Resistor, European symbol		
R17	3.3 k	R-EU_R0603	R0603	Resistor, European symbol		
R18	n.b.	R-EU_R0603	R0603	Resistor, European symbol, do not assemble		
R19	0	R-EU_R0603	R0603	Resistor, European symbol,		
R20	0	R-EU_R0603	R0603	Resistor, European symbol		
R21	n.b.	R-EU_R0603	R0603	Resistor, European symbol, do not assemble		
R22	100 k	BOURNS_POT I	BOURNS_PO TI	Potentiometer with shaft and rotary knob	RS-Components	737-7824 / 259-6929
R23	3.3 k	R-EU_R0603	R0603	Resistor, European symbol		
R24	3.3 k	R-EU_R0603	R0603	Resistor, European symbol		
R25	n.b.	R-EU_R0603	R0603	Resistor, European symbol, do not assemble		
R26	n.b.	R-EU_R0603	R0603	Resistor, European symbol, do not assemble		
T1		BSC026N08NS5	PG-TDSON-8	Infineon OptiMOS™ BSC026N08NS5		
T2		BSC026N08NS5	PG-TDSON-8	Infineon OptiMOS™ BSC026N08NS5		
VOU T		BANANA_SOCKET	BANANA_SOCKET	4 mm banana socket	RS-Components	738-547
X1		733980-62	733980-62	Female print connector	Distrelec	142-05-102
X2	HV_PROBEHOLDER	HV_PROBEHOLDER	HV_PROBEHOLDER		Digi-Key	PK106-4-ND
X3	HV_PROBEHOLDER	HV_PROBEHOLDER	HV_PROBEHOLDER		Digi-Key	PK106-4-ND
X4	HV_PROBEHOLDER	HV_PROBEHOLDER	HV_PROBEHOLDER		Digi-Key	PK106-4-ND
X5	IPROBED RAHTBRUECKE	IPROBEDRAHTBRUECKE	CURRENT_PROBE	Wire for current measurements		

4 References

- [1] “Applications of 1EDNx550 single-channel low-side EiceDRIVER™ with truly differential inputs”. AN_1803_PL52_1804_112257.
- [2] “Evaluation Board for XMC1000 Family – XMC 2Go Kit with XMC1100”. Board User’s Manual.

Revision history

Revision history

Document version	Date of release	Description of changes
1.1	2023-03-07	Editorial changes
1.0	2018-10-20	Initial release

Trademarks

All referenced product or service names and trademarks are the property of their respective owners.

Edition 2023-03-07

Published by

Infineon Technologies AG

81726 Munich, Germany

© 2023 Infineon Technologies AG.

All Rights Reserved.

Do you have a question about this document?

Email: erratum@infineon.com

Document reference

AN_1805_PL52_1805_091441

IMPORTANT NOTICE

The information contained in this application note is given as a hint for the implementation of the product only and shall in no event be regarded as a description or warranty of a certain functionality, condition or quality of the product. Before implementation of the product, the recipient of this application note must verify any function and other technical information given herein in the real application. Infineon Technologies hereby disclaims any and all warranties and liabilities of any kind (including without limitation warranties of non-infringement of intellectual property rights of any third party) with respect to any and all information given in this application note.

The data contained in this document is exclusively intended for technically trained staff. It is the responsibility of customer's technical departments to evaluate the suitability of the product for the intended application and the completeness of the product information given in this document with respect to such application.

For further information on the product, technology, delivery terms and conditions and prices please contact your nearest Infineon Technologies office (www.infineon.com).

WARNINGS

Due to technical requirements products may contain dangerous substances. For information on the types in question please contact your nearest Infineon Technologies office.

Except as otherwise explicitly approved by Infineon Technologies in a written document signed by authorized representatives of Infineon Technologies, Infineon Technologies' products may not be used in any applications where a failure of the product or any consequences of the use thereof can reasonably be expected to result in personal injury.