

# 24 W 12 V 5 V SMPS demo board with ICE5QR2270AZ

## About this document

### Scope and purpose

This document is an engineering report that describes a universal-input 24 W 12 V and 5 V off-line flyback converter using the newest 5<sup>th</sup> generation Infineon quasi resonant CoolSET™ ICE5QR2270AZ. It offers high-efficiency, low-standby power with selectable entry and exit standby power options, a wider  $V_{CC}$  operating range with fast start-up, robust line protection with input over voltage protection (OVP), and brownout and various modes of protection for a highly reliable system. This demo board is designed for users who wish to evaluate the performance of [ICE5QR2270AZ](#) and its ease of use.

### Intended audience

This document is intended for power supply design/application engineers, students, etc., who wish to design low-cost and highly reliable systems of off-line SMPS, such as auxiliary power supplies for white goods, PCs, servers and TVs, or enclosed adapters for blu-ray players, set-top boxes, games consoles, etc.

## Table of contents

<b>About this document</b> .....	<b>1</b>
<b>Table of contents</b> .....	<b>1</b>
<b>1 Abstract</b> .....	<b>3</b>
<b>2 Demo board</b> .....	<b>4</b>
<b>3 Specifications of demo board</b> .....	<b>5</b>
<b>4 Circuit description</b> .....	<b>6</b>
4.1 Line input.....	6
4.2 Start-up.....	6
4.3 Integrated MOSFET and PWM control .....	6
4.4 RCD clamper circuit.....	6
4.5 Output stage.....	6
4.6 Feedback loop .....	6
4.7 Primary side peak-current control .....	6
4.8 Digital frequency reduction .....	7
4.9 Active Burst Mode (ABM) .....	7
<b>5 Protection features</b> .....	<b>8</b>
<b>6 Circuit diagram</b> .....	<b>9</b>
<b>7 PCB layout</b> .....	<b>10</b>
7.1 Top side .....	10
7.2 Bottom side .....	10
<b>8 Bill of materials</b> .....	<b>11</b>
<b>9 Transformer construction</b> .....	<b>13</b>
<b>10 Test results</b> .....	<b>14</b>

**Abstract**

10.1	Efficiency, regulation and output ripple .....	14
10.2	Standby power .....	15
10.3	Line regulation .....	16
10.4	Load regulation .....	17
10.5	Maximum input power .....	18
10.6	ESD immunity (EN 61000-4-2) .....	18
10.7	Surge immunity (EN 61000-4-5) .....	18
10.8	Conducted emissions (EN 55022 class B) .....	18
10.9	Thermal measurement .....	21
<b>11</b>	<b>Waveforms and scope plots .....</b>	<b>22</b>
11.1	Start-up at low/high AC-line input voltage with maximum load .....	22
11.2	Soft-start.....	22
11.3	Drain and CS voltage at maximum load.....	23
11.4	Zero crossing point during normal operation.....	23
11.5	Load transient response (dynamic load from 10% to 100%) .....	24
11.6	Output ripple voltage at maximum load.....	24
11.7	Output ripple voltage at burst mode 1 W load.....	25
11.8	Entering Active Burst Mode (ABM) .....	25
11.9	During Active Burst Mode (ABM) .....	26
11.10	Leaving Active Burst Mode (ABM) .....	26
11.11	Line OVP (non-switch auto restart) .....	27
11.12	Brownout protection (non-switch auto restart) .....	27
11.13	V <sub>CC</sub> OVP (odd-skip auto restart).....	28
11.14	V <sub>CC</sub> under-voltage protection (auto restart) .....	28
11.15	Over-load protection (odd-skip auto restart) .....	29
11.16	Output OVP (odd-skip auto restart).....	29
11.17	V <sub>CC</sub> short-to-GND protection .....	30
<b>12</b>	<b>References .....</b>	<b>31</b>
	<b>Revision history .....</b>	<b>32</b>

---

## Abstract

### 1 Abstract

This application note is an engineering report for a 24 W 12 V and 5 V demo board designed in a quasi-resonant flyback converter topology using the 5<sup>th</sup> generation quasi resonant CoolSET™ [ICE5QR2270AZ](#). The target applications of ICE5QR2270AZ are in set-top boxes, portable games controllers and blu-ray/DVD players, or in auxiliary power supplies for home appliances/white goods, PCs, printers, TVs, home theater/audio systems, etc. With the CoolMOS™ integrated into this IC, it greatly simplifies the design and layout of the PCB. The improved digital frequency reduction with proprietary quasi resonant operation offers lower EMI and higher efficiency for a wide AC range by reducing the switching frequency difference between low- and high-line. The enhanced active burst mode power enables flexibility in standby power operation range selection, and quasi resonant operation during active burst mode. As a result, the system efficiency over the entire load range is significantly improved compared to a conventional free-running quasi resonant converter implemented with only maximum switching frequency limitation at light loads. In addition, numerous adjustable protection functions have been implemented in ICE5QR2270AZ to protect the system and customize the IC for the chosen application. In case of failure modes such as brownout or line over-voltage,  $V_{CC}$  over-/under-voltage, open control-loop or over-load, output over-voltage, over-temperature,  $V_{CC}$  short-to-ground and Current Sense (CS) short-to-ground, the device enters protection mode. By means of the cycle-by-cycle peak current limitation, the dimensions of the transformer and the current rating of the secondary diode can both be optimized. Thus, a cost-effective solution can easily be achieved.

Demo board

## 2 Demo board

This document contains the list of features, the power-supply specifications, schematics, bill of materials and the transformer construction documentation. Typical operating characteristics such as performance curve and scope waveforms are shown at the end of the report.

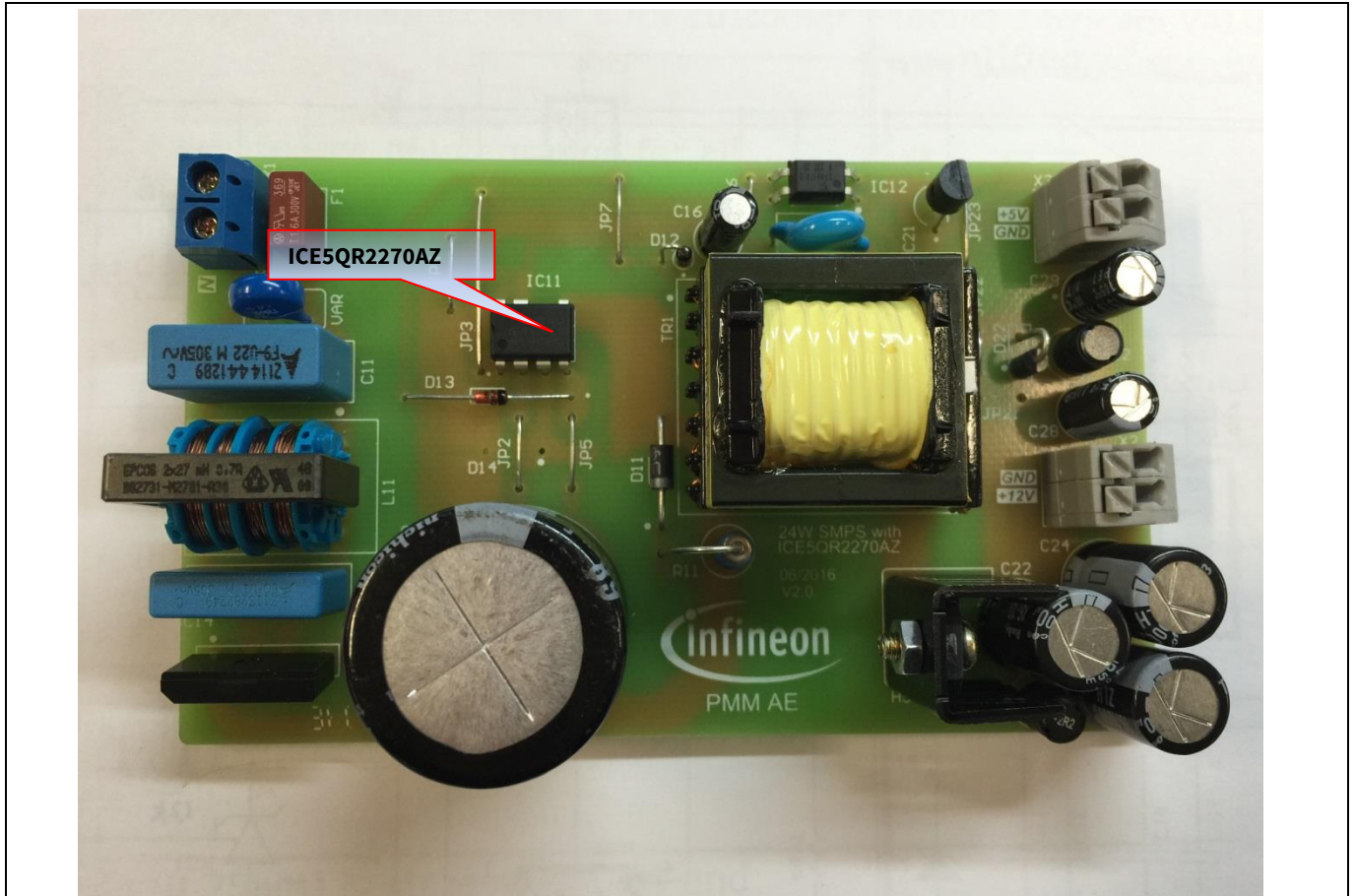

Figure 1 DEMO\_5QR2270AZ\_24W1

---

**Specifications of demo board**

### 3 Specifications of demo board

**Table 1 Specifications of DEMO\_5QR2270AZ\_24W1**

Input voltage and frequency	85 V AC (60 Hz)~300 V AC (50 Hz)
Output voltage, current and power	(12 V x 1.92 A) + (5 V x 0.2 A) = 24 W
Regulation	+5 V: less than $\pm 5\%$ +12 V: less than $\pm 10\%$
Output ripple voltage (full load, 85 V AC~300 V AC)	5 V <sub>ripple_p-p</sub> < 100 mV 12 V <sub>ripple_p-p</sub> < 200 mV
Active mode four-point average efficiency (25%, 50%, 75%, 100% load)	> 83% at 115 V AC and 230 V AC
No-load power consumption	< 100 mW at 230 V AC
Conducted emissions (EN 55022 class B)	Pass with 10 dB margin for 115 V AC and 6 dB margin for 230 V AC
ESD immunity (EN 61000-4-2)	Special level ( $\pm 14$ kV for contact and $6\pm 14$ kV air discharge)
Surge immunity (EN 61000-4-5)	Installation class 4 ( $\pm 2$ kV for line-to-line and $\pm 4$ kV for line-to-earth)
Form factor case size (L x W x H)	(110 x 66 x 27) mm <sup>3</sup>

**Note:** *The demo board is designed for dual output with cross-regulated loop feedback. It may not regulate properly if loading is applied only to single output. If the user wants to evaluate for single output (12 V only) conditions, the following changes are necessary on the board.*

*1. Remove D22, L22, C28, C210, R25A (to disable 5 V output)*

*2. Change R26 to 10 k $\Omega$  and R25 to 38 k $\Omega$  (to disable 5 V feedback and enable 100% weighted factor on 12 V output)*

*Since the board (especially the transformer) is designed for dual output with optimized cross-regulation, single-output efficiency might not be optimized. It is only for IC functional evaluation under single-output conditions.*

---

## Circuit description

### 4 Circuit description

#### 4.1 Line input

The AC-line input side comprises the input fuse F1 as over-current protection. The choke L11, X-capacitor C11 and Y-capacitor C12 act as EMI suppressors. The sparking gap and varistor VAR can absorb high-voltage stress during a lightning surge test. A rectified DC voltage (120~424 V DC) is obtained through the bridge rectifier BR1 together with the bulk capacitor C13.

#### 4.2 Start-up

To achieve fast and safe start-up, ICE5QR2270AZ is implemented with start-up resistor and  $V_{CC}$  short-to-GND protection. When  $V_{VCC}$  reaches the turn-on voltage threshold 16 V, the IC begins with a soft-start. The soft-start implemented in ICE5QR2270AZ is a digital time-based function. The preset soft-start time is 12 ms with four steps. If not limited by other functions, the peak voltage on the CS pin will increase in increments from 0.3 V to 1 V. After the IC turns on, the  $V_{CC}$  voltage is supplied by auxiliary windings of the transformer.  $V_{CC}$  short-to-GND protection is implemented during the start-up time.

#### 4.3 Integrated MOSFET and PWM control

ICE5QR2270AZ is comprised of a power MOSFET and the new proprietary quasi resonant controller, which enables higher average efficiency and low EMI. This integrated solution greatly simplifies the circuit layout and reduces the cost of PCB manufacture. The PWM switch-on is determined by the Zero Crossing Detection (ZCD) input signal and the value of the up/down counter. The PWM switch-off is determined by the feedback signal  $V_{FB}$  and the CS signal  $V_{CS}$ . ICE5QR2270AZ also performs all protection functions necessary in flyback converters. Details about the information mentioned above are illustrated in the product datasheet.

#### 4.4 RCD clamper circuit

A clamper network (R11, C15 and D11) dissipates the energy of the leakage inductance and suppresses ringing on the SMPS transformer.

#### 4.5 Output stage

There are two outputs on the secondary side, 12 V and 5 V. The power is coupled out via Schottky diodes D21 and D22. The capacitors C22 and C28 provide energy buffering, followed by the L-C filters L21–C24 and L22–C210 to reduce the output ripple and prevent interference between SMPS switching frequency and line frequency. Storage capacitors C22 and C28 are designed to have as small an internal resistance (ESR) as possible to minimize the output voltage ripple caused by the triangular current.

#### 4.6 Feedback loop

For feedback, the output is sensed by the voltage divider of R26, R25 and R25A and compared to the IC21 (TL431) internal reference voltage. C25, C26 and R24 comprise the compensation network. The output voltage of IC21 (TL431) is converted to the current signal via optocoupler IC12 and two resistors, R22 and R23, for regulation control.

#### 4.7 Primary side peak-current control

The MOSFET drain source current is sensed via external resistors R14 and R14A. Since ICE5QR2270AZ is a current mode controller, it would have a cycle-by-cycle primary current and feedback voltage control, which ensures the converter's maximum power is controlled in every switching cycle.

## Circuit description

For a quasi resonant flyback converter, the maximum possible output power is increased when a constant current limit value is used for the whole-line input voltage range. This is usually not desirable, as this will increase the cost of the transformer and output diode in case of output over-power conditions. Internal current limitation with a line-dependent  $V_{CS}$  curve and the new proprietary quasi resonant switching, which reduces switching frequency difference between the minimum and maximum line, are implemented in the ICE5QR2270AZ. As a result, the maximum output power can be limited against the input voltage.

### 4.8 Digital frequency reduction

During normal operation, the switching frequency for ICE5QR2270AZ is digitally reduced with decreasing load. At light loads, the MOSFET will be turned on – not at the first minimum drain-source voltage time, but on the  $n^{\text{th}}$ . The counter is within a range of 1 to 8 for low-line and 3 to 10 for high-line, which depends on feedback voltage in a time-base. The feedback voltage decreases when the output power requirement decreases, and vice versa. Therefore, the counter is set by monitoring voltage  $V_{FB}$ . The counter will be increased with low  $V_{FB}$  and decreased with high  $V_{FB}$ . The thresholds are preset inside the IC.

### 4.9 Active Burst Mode (ABM)

Active Burst Mode (ABM) entry and exit power (two levels) can be selected in ICE5QR2270AZ. Details are illustrated in the product datasheet. In light load conditions, the SMPS enters into active burst mode with quasi resonant switching. At this stage, the controller is always active but the  $V_{VCC}$  must be kept above the switch-off threshold. During active burst mode, the efficiency increases significantly and at the same time it supports low ripple on  $V_{out}$  and fast response on load-jump.

For determination of entering active burst mode operation, three conditions apply:

1. The feedback voltage is lower than the threshold of  $V_{FBEB}$
2. The up/down counter is 8 for low-line and 10 for high-line, and
3. A certain blanking time ( $t_{BEB}=20$  ms) is required.

Once all of these conditions are fulfilled, the active burst mode flip-flop is set and the controller enters active burst mode operation. This multi-condition determination for entering active burst mode operation prevents mis-triggering of active burst mode, so that the controller enters active burst mode operation only when the output power is really low during the preset blanking time.

During active burst mode, the maximum CS voltage is reduced from 1 V to 0.31/0.35 V to reduce the conduction loss and the audible noise. In active burst mode, the Feedback (FB) voltage changes like a sawtooth between 2 V and 2.4 V.

The feedback voltage immediately increases if there is a high load-jump. This is observed by one comparator. As the current limit is 31/35% during active burst mode a certain load is needed so that feedback voltage can exceed  $V_{FBLB}$  (2.75 V). After leaving active burst mode, maximum current can now be provided to stabilize  $V_{out}$ . In addition, the up/down counter will be set to 1 (low-line) or 3 (high-line) immediately after leaving active burst mode. This is helpful to decrease the output voltage undershoot.

---

**Protection features**

## 5 Protection features

Protection is one of the major factors in determining whether the system is safe and robust – therefore sufficient protection is necessary. ICE5QR2270AZ provides comprehensive protection to ensure the system is operating safely. This includes line over-voltage, brownout,  $V_{CC}$  over-voltage and under-voltage, over-load, output over-voltage, over-temperature (controller junction), CS short-to-GND, and  $V_{CC}$  short-to-GND. When those faults are found, the system will go into protection mode. Once the fault is removed, the system resumes normal operation. A list of protections and failure conditions are shown in the table below.

**Table 2 Protection functions of ICE5QR2270AZ**

Protection function	Failure condition	Protection mode
Line over-voltage	$V_{VIN} > 2.9 \text{ V}$	Non-switch auto restart
Brownout	$V_{VIN} < 0.4 \text{ V}$	Non-switch auto restart
$V_{CC}$ over-voltage	$V_{VCC} > 25 \text{ V}$	Odd-skip auto restart
$V_{CC}$ under voltage	$V_{VCC} < 10 \text{ V}$	Auto restart
Over-load	$V_{FB} > 2.75 \text{ V}$ and lasts for 30 ms	Odd-skip auto restart
Output over-voltage	$V_{ZCD} > 2 \text{ V}$ and lasts for 10 consecutive pulses	Odd-skip auto restart
Over-temperature (junction temperature of controller chip only)	$T_J > 140^\circ\text{C}$	Non-switch auto restart
CS short to GND	$V_{CS} < 0.1 \text{ V}$ , lasts for 5 $\mu\text{s}$ and 3 consecutive pulses	Odd-skip auto restart
$V_{CC}$ short to GND ( $V_{VCC} = 0 \text{ V}$ , $R_{\text{Start-up}} = 50 \text{ M}\Omega$ and $V_{\text{DRAIN}} = 90 \text{ V}$ )	$V_{VCC} < 1.2 \text{ V}$ , $I_{VCC\_Charge1} \approx 0.2 \text{ A}$	Cannot start up



Circuit diagram

## 6 Circuit diagram

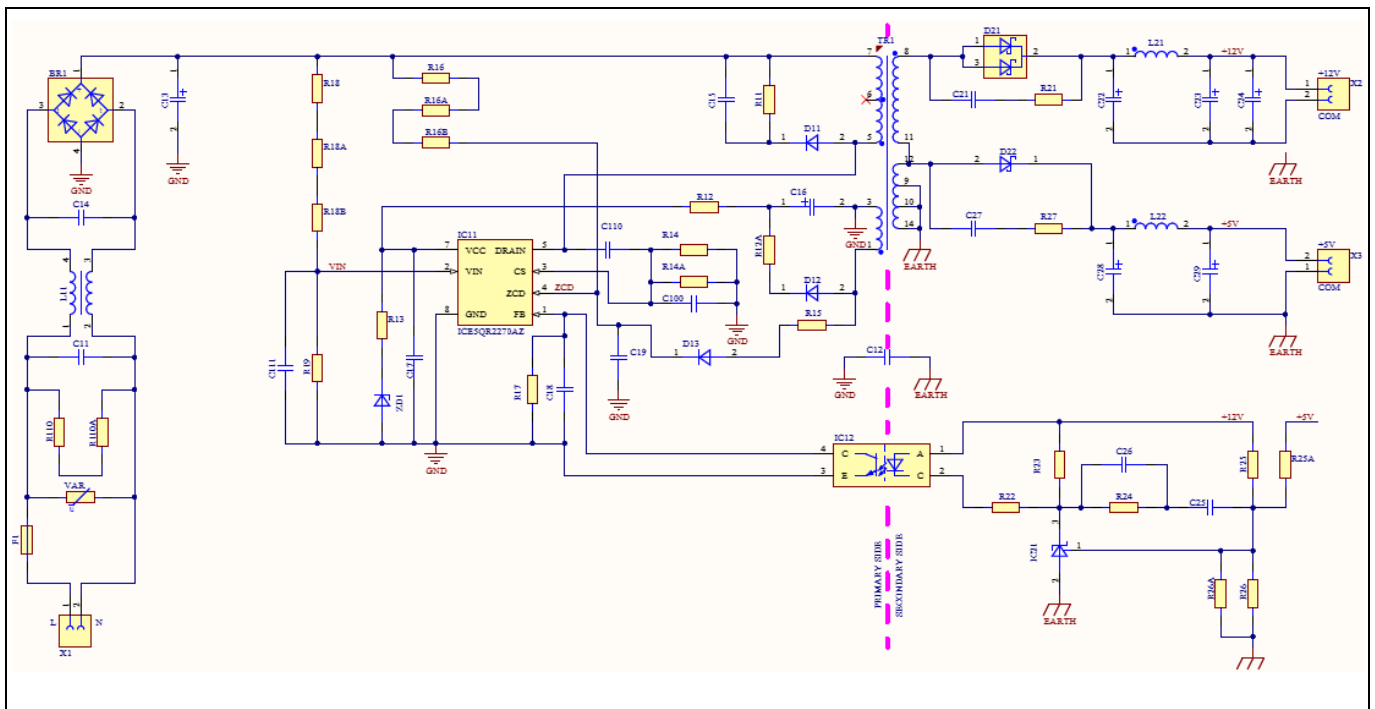

Figure 2 Schematic of DEMO\_5QR2270AZ\_24W1

Note: General guidelines for layout design of PCB:

1. Star ground at bulk capacitor C13: all primary grounds should be connected to the ground of bulk capacitor C13 separately in one point. This effectively reduces the switching noise going into the sensitive pins of the CoolSET™ device. The primary star ground can be split into four groups as follows:
  - i. Combine signal (all small signal grounds connecting to the CoolSET™ GND pin, such as filter capacitor grounds C17, C18, C19 and optocoupler ground) and power ground (CS resistor R14 and R14A)
  - ii. V<sub>CC</sub> ground includes the V<sub>CC</sub> capacitor ground C16 and the auxiliary winding ground, pin 3 of the power transformer
  - iii. EMI return ground includes Y capacitor C12
  - iv. DC ground from bridge rectifier, BR1
2. Filter capacitor close to the controller ground: filter capacitors C17, C18 and C19 should be placed as close to the controller ground and the controller pin as possible to reduce the switching noise coupled into the controller.
3. High-voltage traces clearance: high-voltage traces should retain enough spacing from the nearby traces. Otherwise, arcing could occur.
  - i. 400 V traces (positive rail of bulk capacitor C13) to nearby trace: greater than 2.0 mm
  - ii. 600 V traces (drain voltage of CoolSET™ IC11) to nearby trace: greater than 2.5 mm
4. Recommended minimum 232 mm<sup>2</sup> copper areas at drain pin to add on PCB for better thermal performance.
5. Power-loop area (bulk capacitor C13, primary winding of the transformer TR1 (pins 7 and 5), IC11 drain pin, IC11 CS pin and CS resistor R14/R14A) should be as small as possible to minimize the switching emissions.

PCB layout

7 PCB layout

7.1 Top side

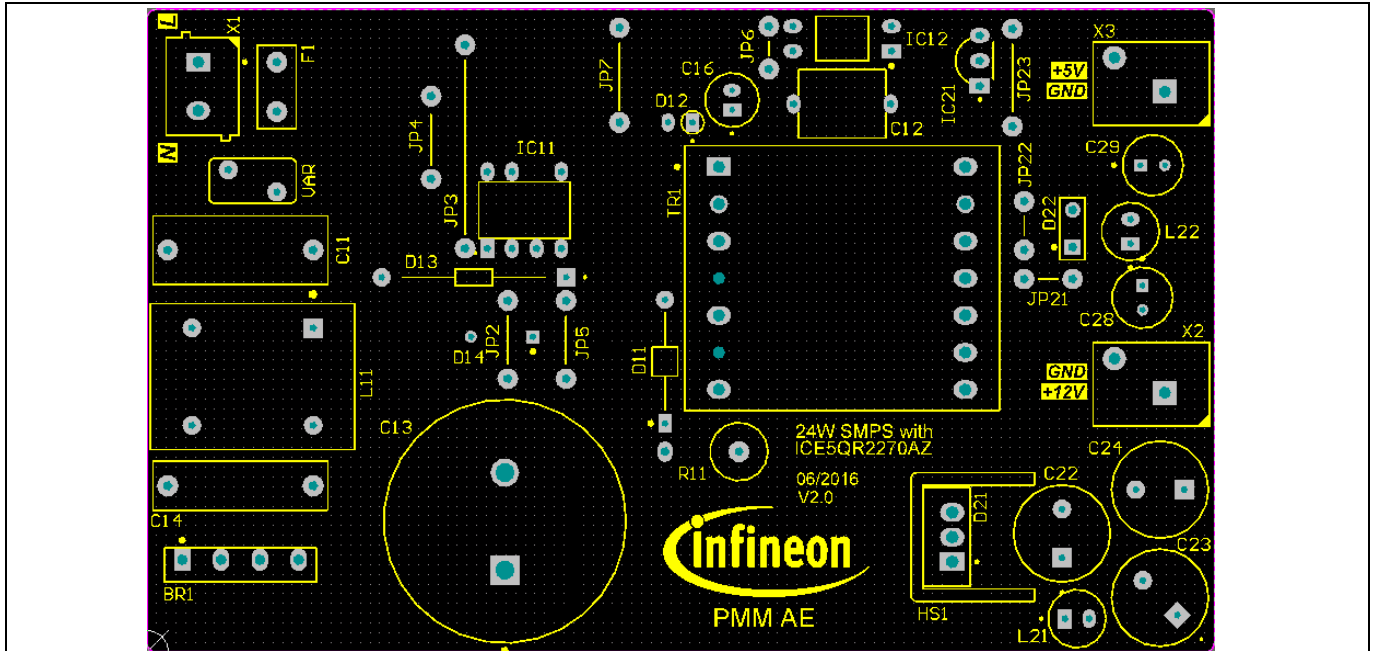

Figure 3 Top side component legend

7.2 Bottom side

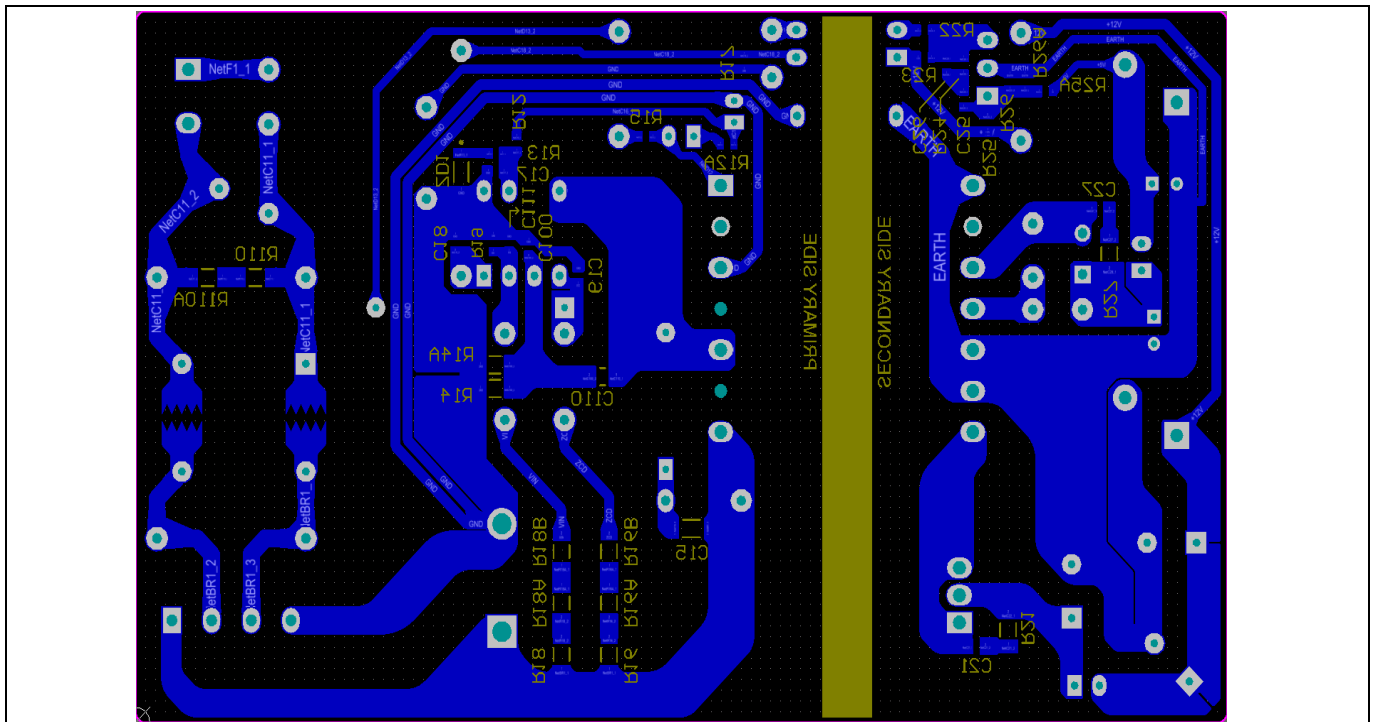

Figure 4 Bottom side copper and component legend

## Bill of materials

## 8 Bill of materials

Table 3 Bill of materials (V 0.7)

No.	Designator	Description	Part number	Manufacturer	Quantity
1	BR1	600 V/1 A	S1VBA60	Shindengen	1
2	C11	0.22 $\mu$ F/305 V	B32922C3224	Epcos	1
3	C12	2.2 nF/500 V	DE1E3RA222MA4BQ	Murata	1
4	C13	68 $\mu$ F/500 V	LGN2H680MELA25	Nichicon	1
5	C14	0.1 $\mu$ F/305 V	B329221C3104K	Epcos	1
6	C15	1n F/1000 V	GRM31BR73A102KW01#	Murata	1
7	C16	22 $\mu$ F/50 V	50PX22MEFC5X11	Rubycon	1
8	C17	100 nF/50 V	GRM188R71H104KA93D	Murata	1
9	C18, C26, C111	1n F/50 V	GRM1885C1H102GA01D	Murata	3
10	C19	100 pF/50 V	GRM1885C1H101GA01D	Murata	1
11	C22 ,C23, C24	1000 $\mu$ F/16 V	16ZLH1000MEFC10X16	Rubycon	3
12	C25	220 nF/50 V	GRM188R71H224KAC4D	Murata	1
13	C28, C29	330 $\mu$ F/10 V	10ZLH330MEFC6.3X11	Rubycon	2
14	C100	22 nF/25 V	GRM188B11E223KA01D	Murata	1
15	D11	1 A/800 V	UF4006		1
16	D12	0.2 A/200 V	1N485B		1
17	D13	0.2 A/150 V/50 ns	FDH400		1
18	D21	10 A/100 V	MBRF10100CT	Vishay	1
19	D22	1 A/45 V	SB150	Vishay	1
20	F1	1.6 A/300 V	36911600000	Littlefuse	1
21	HS21	Heatsink	577202B00000G	AAVID	1
22	IC11	ICE5QR2270AZ	ICE5QR2270AZ	Infineon	1
23	IC12	Optocoupler	SFH617A-3		1
24	IC21	Shunt regulator	TL431BVLPG		1
25	L11	27 mH/0.7 A	B82731M2701A030	Epcos	1
26	L21	2.2 $\mu$ H/4.3 A	744 746 202 2	Würth Electronics	1
27	L22	4.7 $\mu$ H/4.2 A	744 746 204 7	Würth Electronics	1
28	R11	68 k $\Omega$ /2 W/500 V	MO2CT631R683J	KOA Speer	1
29	R12, R13	0 $\Omega$ (0603)			2
30	R12A	4.7 $\Omega$ (0603)			1
31	R14	1.2 R/0.25W/ $\pm$ 1%	ERJ8RQF1R2V	Panasonic	1
32	R14A	1.3 R/0.33 W/ $\pm$ 1%	ERJ8BQF1R3V	Panasonic	1
33	R15	30 k $\Omega$ / $\pm$ 1% (0603)			1
34	R16, R16A, R16B	15 MR/0.25 W/5%	RC1206JR-0715ML		3
35	R18, R18A, R18B	3 MR/0.25 W/1%	RC1206FR-073ML		3
36	R19	58.3 k $\Omega$ /0.1 W/0.5%	RT0603DRE0758K3L		1
37	R110, R110A	1.5 M $\Omega$ /5%/200 V	RC1206FR-071M5L		2
38	R22	820 $\Omega$ (0603)			1
39	R23	1.2 k $\Omega$ (0603)			1
40	R24	68 k $\Omega$ (0603)			1
41	R25	110 k $\Omega$ (0603)			1

---

**Bill of materials**

42	R25A	15 k $\Omega$ (0603)			1
43	R26	10 k $\Omega$ (0603)			1
44	TR1	400 $\mu$ H	750343101(Rev 0.2)	Würth Electronics	1
45	VAR	0.25 W/320 V	B72207S2321K101	Epcos	1
46	ZD1	22 V Zener			1
47	Con (L N)	Connector	691102710002	Würth Electronics	1
48	Con (+12 V com), Con (+5 V com)	Connector	691 412 120 002B	Würth Electronics	2

Transformer construction

## 9 Transformer construction

Core and materials: EE25/13/7(EF25), TP4A (TDG)

Bobbin: 070-5644 (14-pin, THT, horizontal version)

Primary inductance:  $L_p = 400 \mu\text{H}$  ( $\pm 10\%$ ), measured between pin 5 and pin 7

Manufacturer and part number: Würth Electronics Midcom (750343101)

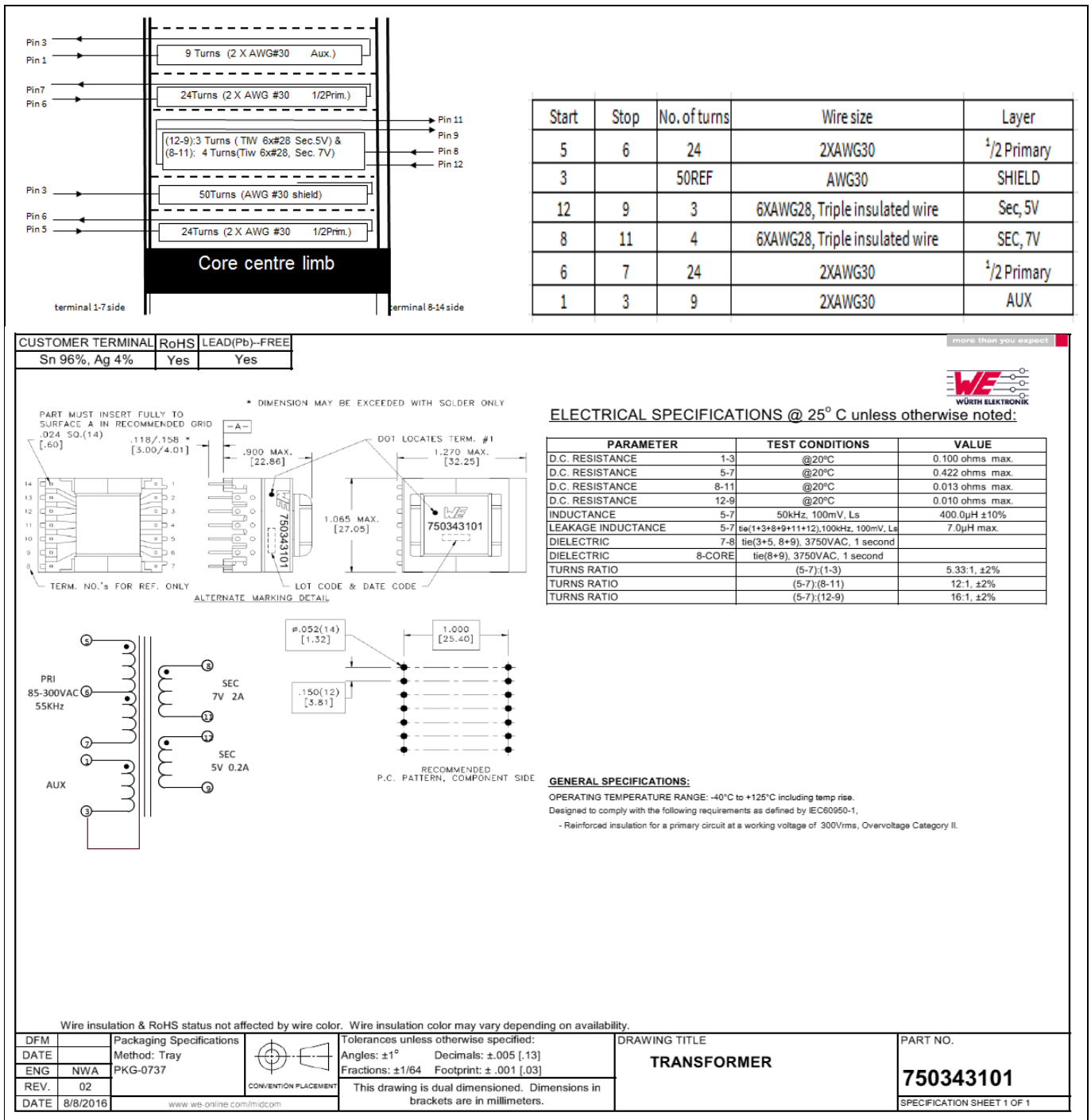

Figure 5 Transformer structure

Test results

# 10 Test results

## 10.1 Efficiency, regulation and output ripple

**Table 4 Efficiency, regulation and output ripple**

Input (V AC/Hz)	P <sub>in</sub> (W)	V <sub>out1</sub> (V DC)	I <sub>out1</sub> (A)	V <sub>outR</sub> PP1 (mV)	V <sub>out2</sub> (V DC)	I <sub>out2</sub> (A)	V <sub>outR</sub> PP2 (mV)	P <sub>out</sub> (W)	Efficiency η (%)	Average η (%)	OLP P <sub>in</sub> (W)	OLP I <sub>out12V</sub> (fixed 5 V at 0.2 A) (A)
85 V AC/ 60 Hz	0.03650	4.92	0.000	20	11.94	0.000	50	/	/	/	39.00	2.60
	0.08200	4.79	0.006	75	12.88	0.000	33	0.03	35.05	/		
	7.45	4.93	0.050	15	11.92	0.500	60	6.21	83.31	82.55		
	14.59	4.94	0.060	15	11.85	1.000	83	12.15	83.25			
	14.92	4.93	0.100	15	11.91	1.000	86	12.40	83.13			
	22.44	4.93	0.150	15	11.91	1.500	91	18.60	82.91			
29.53	4.93	0.200	18	11.92	1.920	120	23.87	80.84				
115 V AC/ 60 Hz	0.04100	4.94	0.000	22	11.94	0.000	51	/	/	/	43.00	2.90
	0.08600	4.79	0.006	78	12.9	0.000	33	0.03	33.42	/		
	7.46	4.93	0.050	15	11.92	0.500	56	6.21	83.20	83.53		
	14.57	4.94	0.060	17	11.85	1.000	98	12.15	83.37			
	14.90	4.93	0.100	17	11.92	1.000	98	12.41	83.31			
	22.29	4.93	0.150	17	11.92	1.500	108	18.62	83.53			
28.37	4.93	0.200	17	11.91	1.920	101	23.85	84.08				
230 V AC/ 50 Hz	0.07250	4.93	0.000	22	11.94	0.000	55	/	/	/	44.00	3.00
	0.12000	4.78	0.006	80	12.95	0.000	33	0.03	23.92	/		
	7.70	4.93	0.050	13	11.93	0.500	68	6.21	80.67	83.01		
	14.58	4.94	0.060	15	11.84	1.000	93	12.14	83.24			
	14.89	4.93	0.100	17	11.92	1.000	88	12.41	83.36			
	22.22	4.93	0.150	17	11.92	1.500	100	18.62	83.80			
28.35	4.93	0.200	17	11.92	1.920	108	23.87	84.21				
265 V AC/ 50 Hz	0.08570	4.92	0.000	22	11.93	0.000	56	/	/	/	45.00	3.09
	0.13730	4.78	0.006	80	12.96	0.000	35	0.03	20.89	/		
	7.85	4.93	0.050	13	11.92	0.500	68	6.21	79.06	81.79		
	14.86	4.94	0.060	13	11.86	1.000	93	12.16	81.81			
	15.16	4.93	0.100	13	11.93	1.000	95	12.42	81.95			
	22.52	4.93	0.150	15	11.92	1.500	100	18.62	82.68			
28.62	4.93	0.200	17	11.93	1.920	111	23.89	83.48				
300 V AC/ 50 Hz	0.10900	4.92	0.000	23	11.93	0.000	55	/	/	/	47.00	3.27
	0.16040	4.78	0.006	80	12.95	0.000	33	0.03	17.88	/		
	8.09	4.93	0.050	15	11.92	0.500	63	6.21	76.74	80.73		
	14.94	4.94	0.060	15	11.86	1.000	106	12.16	81.37			
	15.27	4.93	0.100	15	11.93	1.000	108	12.42	81.36			
	22.66	4.93	0.150	15	11.92	1.500	115	18.62	82.17			
28.90	4.93	0.200	15	11.93	1.920	115	23.89	82.67				

Minimum load condition : 5 V @ 6 mA  
 Typical load condition : 5 V @ 60 mA and 12 V @ 1 A  
 Maximum load condition : 5 V @ 200 mA and 12 V @ 1.92 A

Test results

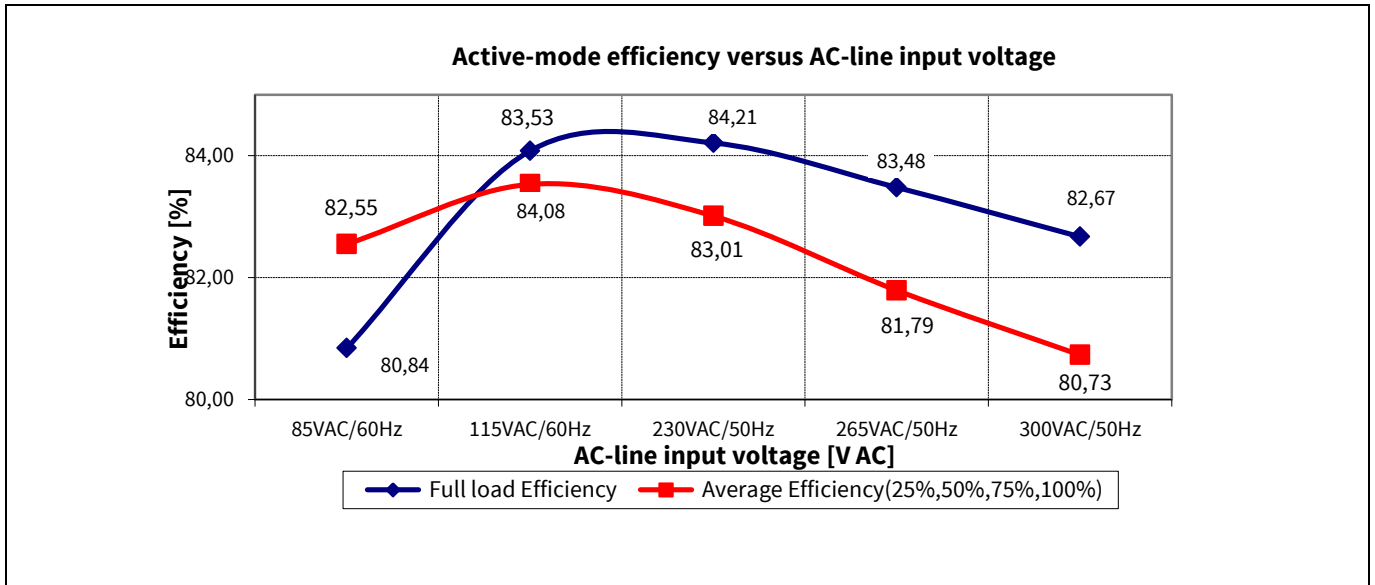

Figure 6 Efficiency vs AC-line input voltage

10.2 Standby power

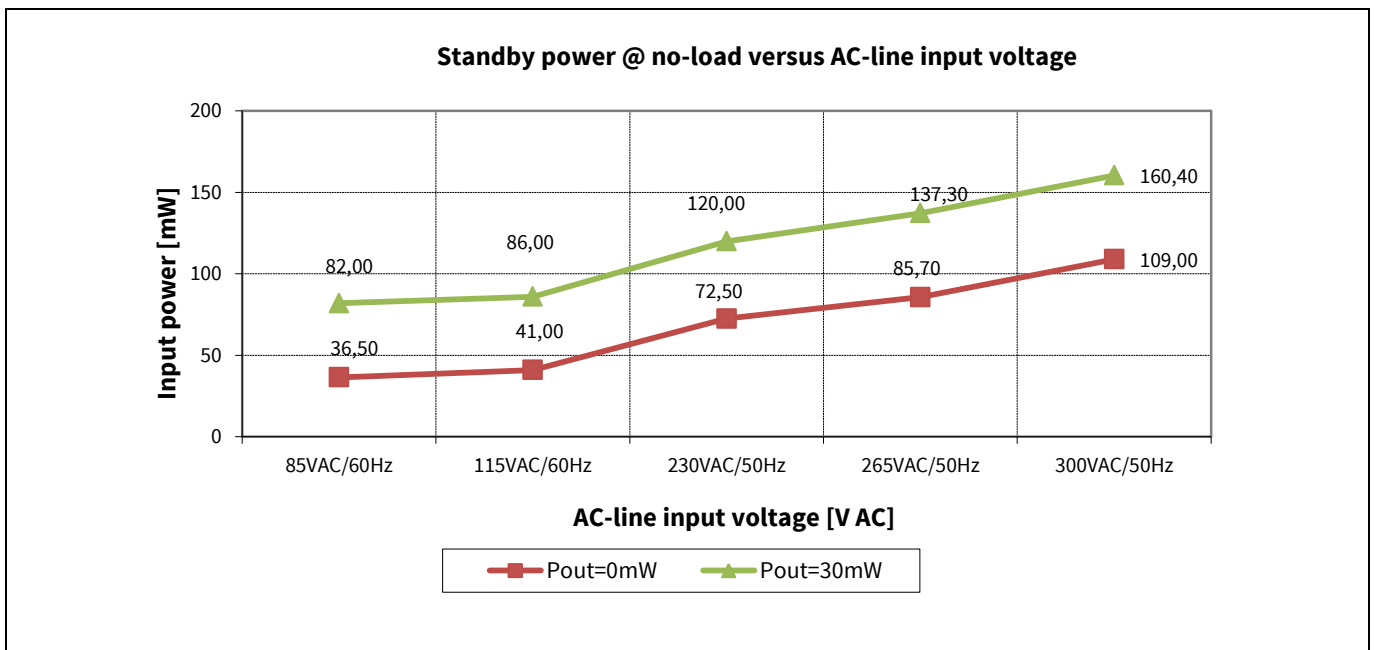

Figure 7 Standby power at no-load and 30 mW load vs AC-line input voltage (measured by Yokogawa WT210 power meter – integration mode)

Test results

10.3 Line regulation

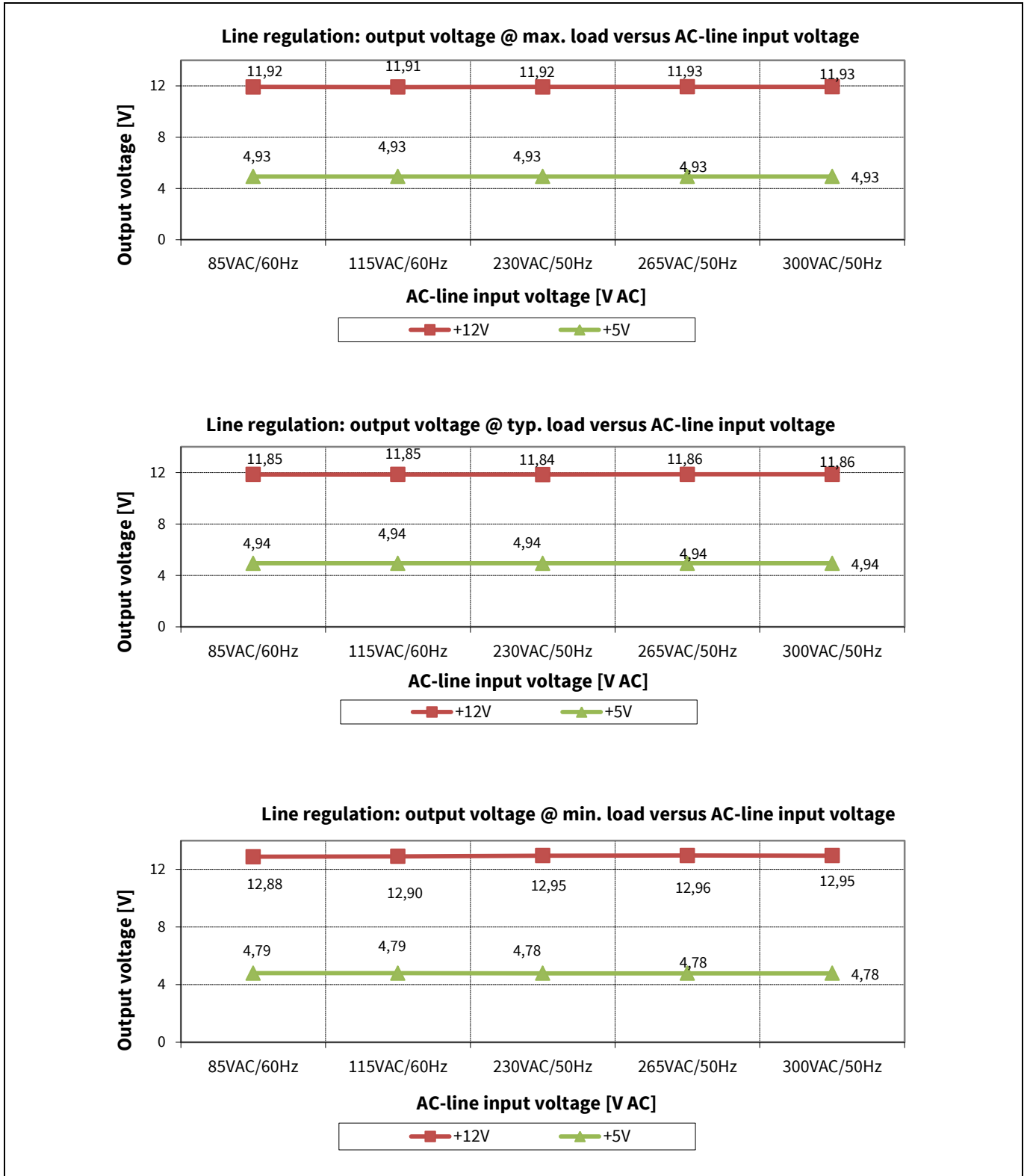

Figure 8 Line regulation  $V_{out}$  at full load vs AC-line input voltage



Test results

10.4 Load regulation

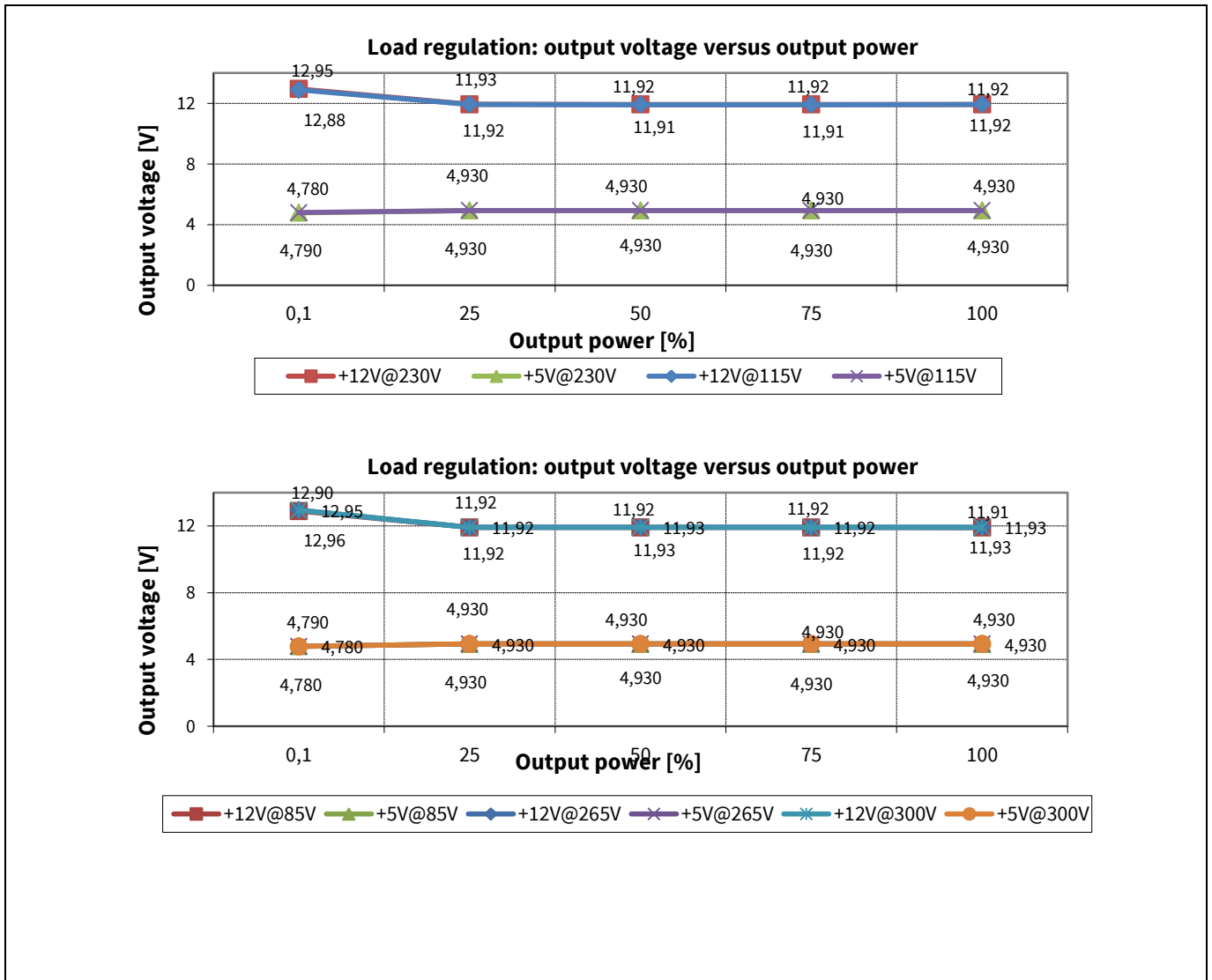

Figure 9 Load regulation  $V_{out}$  vs output power

Test results

10.5 Maximum input power

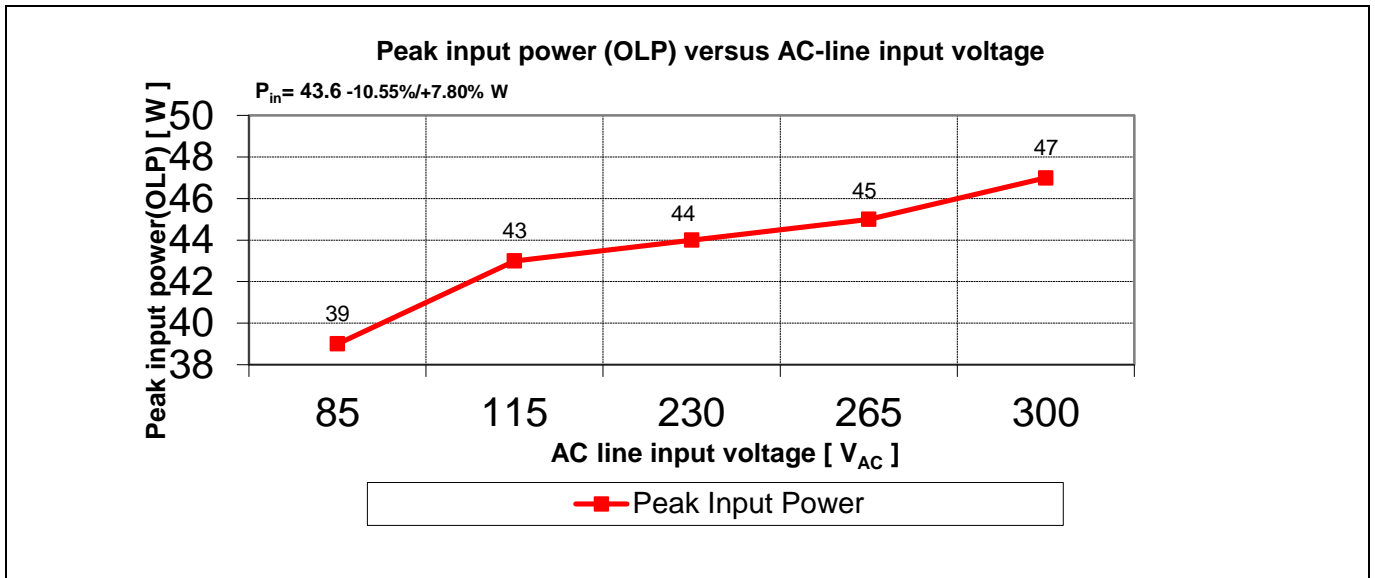

Figure 10 Maximum input power (before over-load protection) vs AC-line input voltage

10.6 ESD immunity (EN 61000-4-2)

Pass EN 61000-4-2 special level (±14 kV for contact discharge and (±16 kV air discharge).

10.7 Surge immunity (EN 61000-4-5)

Pass EN 61000-4-5 installation class 4 (±2 kV for line-to-line and ±4 kV for line-to-earth).<sup>1</sup>

10.8 Conducted emissions (EN 55022 class B)

The conducted EMI was measured with Schaffner (SMR4503) and followed the test standard of EN 55022 (CISPR 22) class B. The demo board was set up at maximum load (24 W) with input voltage of 115 V AC and 230 V AC.

<sup>1</sup> PCB spark gap distance needs to reduce to 0.5 mm and C13 change to 120 µF.

Test results

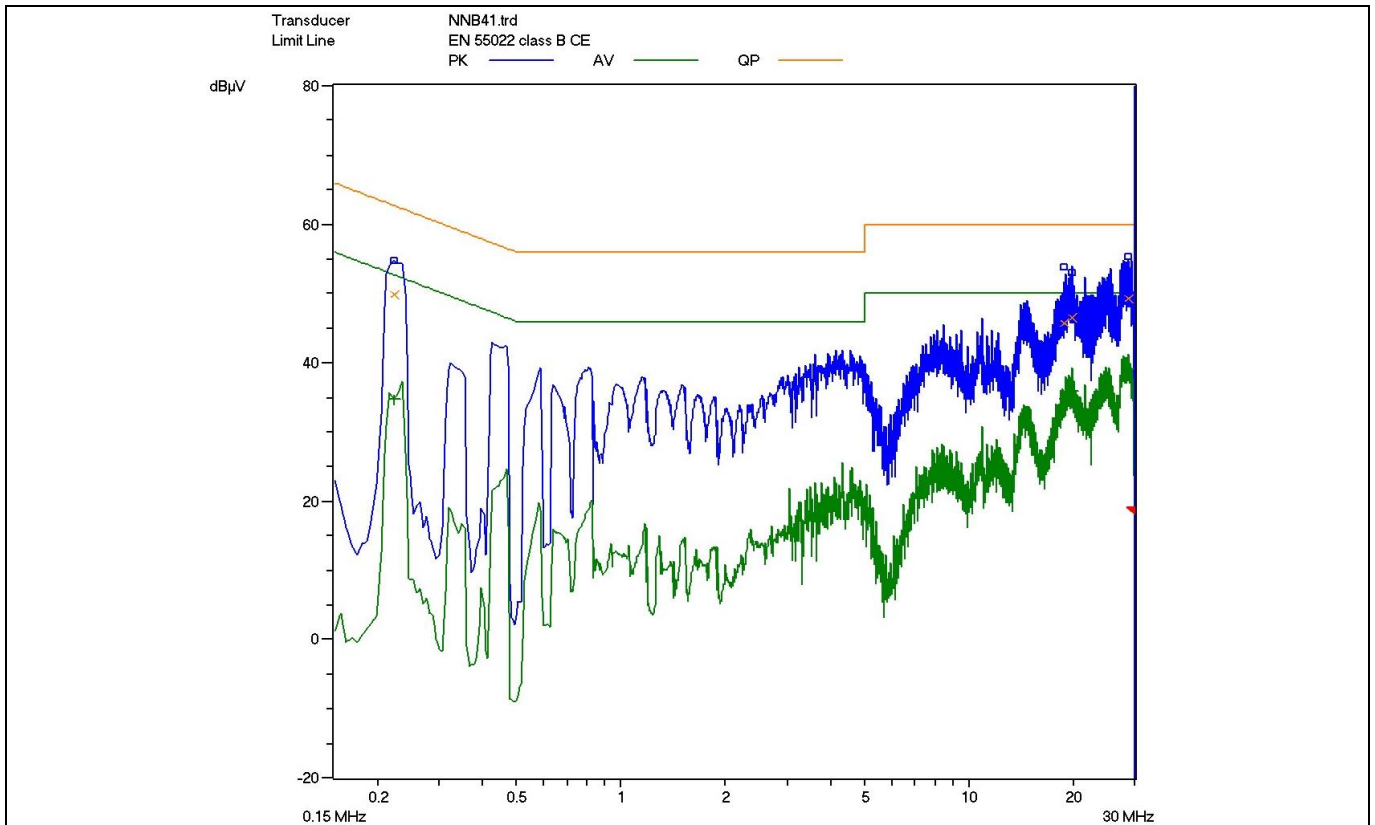

Figure 11 Conducted emissions (line) at 115 V AC and maximum load

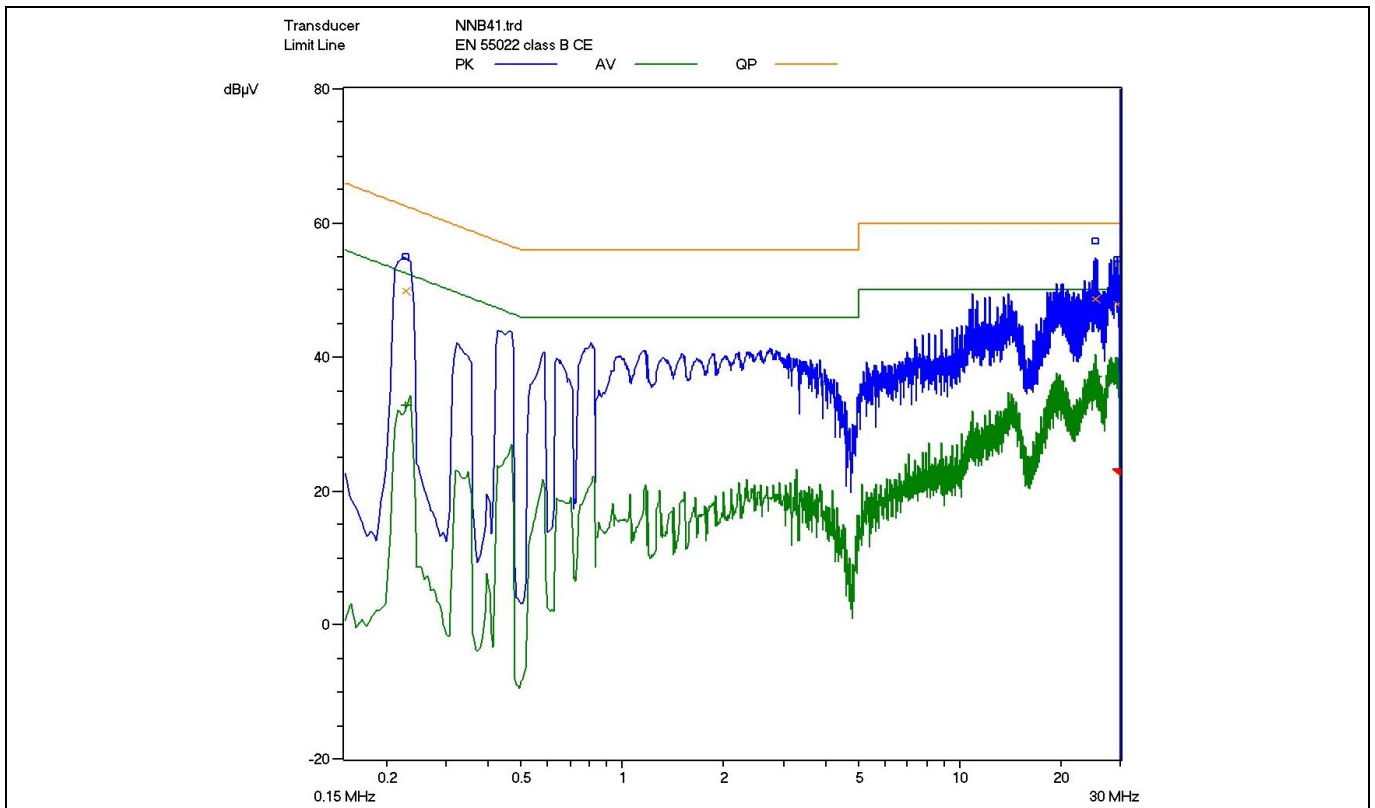

Figure 12 Conducted emissions (neutral) at 115 V AC and maximum load

Pass conducted emissions EN 55022 (CISPR 22) class B with 10 dB margin for quasi-peak measurement at low-line (115 V AC).

Test results

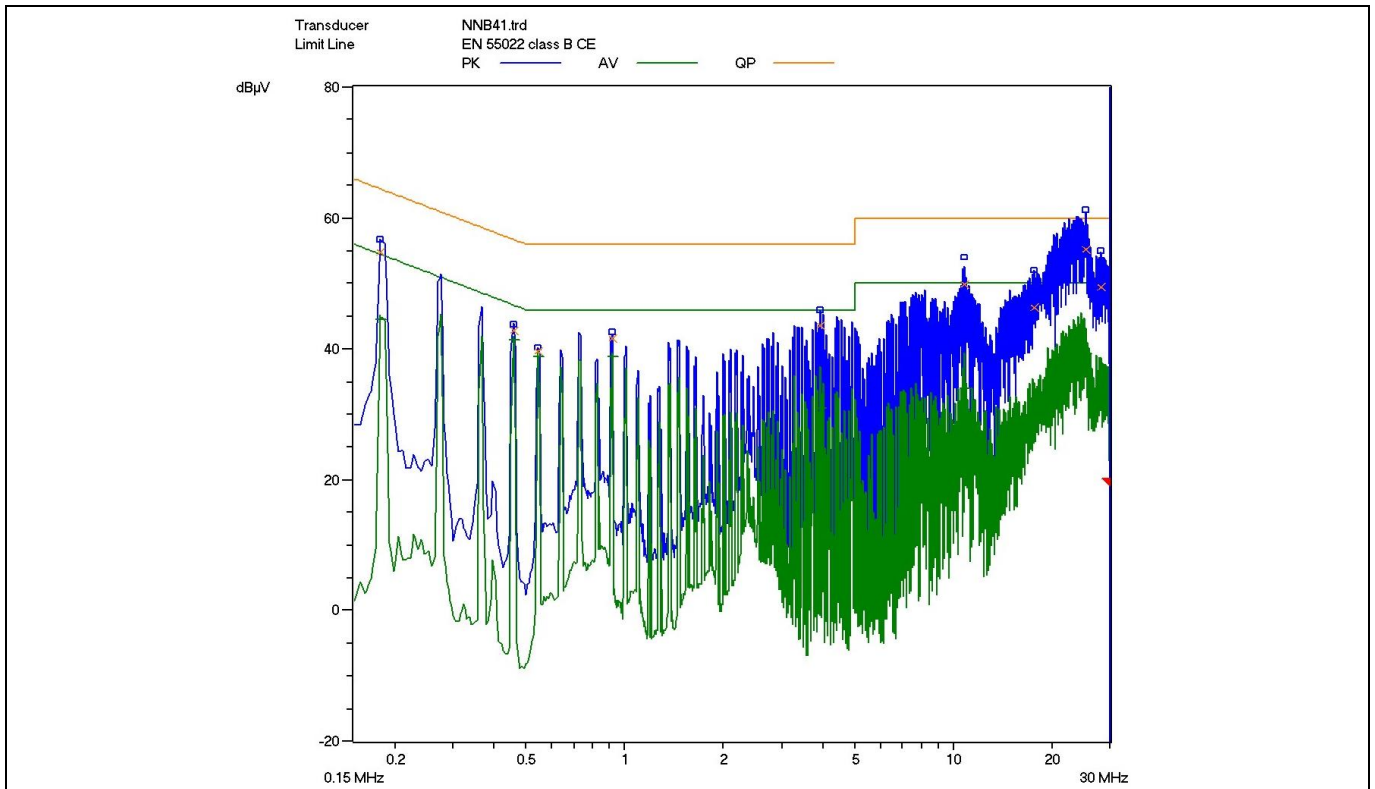

Figure 13 Conducted emissions (line) at 230 V AC and maximum load

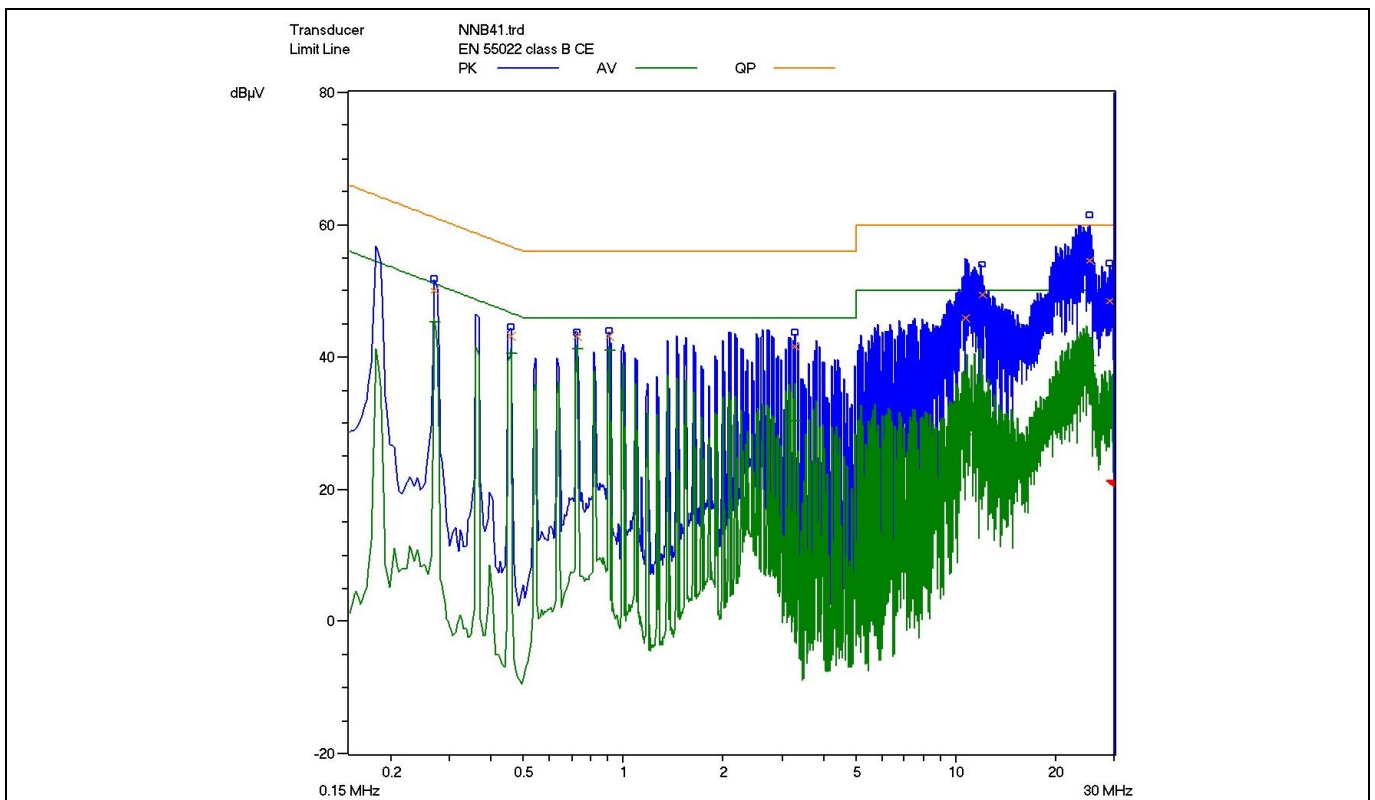

Figure 14 Conducted emissions (neutral) at 230 V AC and maximum load

Pass conducted emissions EN 55022 (CISPR 22) class B with 6 dB margin for quasi-peak measurement at high-line (230 V AC).

Test results

10.9 Thermal measurement

The thermal test of the open-frame demo board was done using an infrared thermography camera (FLIR-T420) at an ambient temperature of 25°C. The measurements were taken after one hour running at full load.

Table 5 Hottest temperature of demo board

No.	Major component	85 V AC (°C)	300 V AC (°C)
1	TR1 (transformer)	51.1	58.9
2	D21 (secondary diode)	70.8	72.2
3	BR1 (bridge diode)	47.0	32.0
4	IC11 (ICE5QR2270AZ)	85.6	88.7
5	L11 (choke)	72.3	36.6
6	Ambient	25.0	25.0

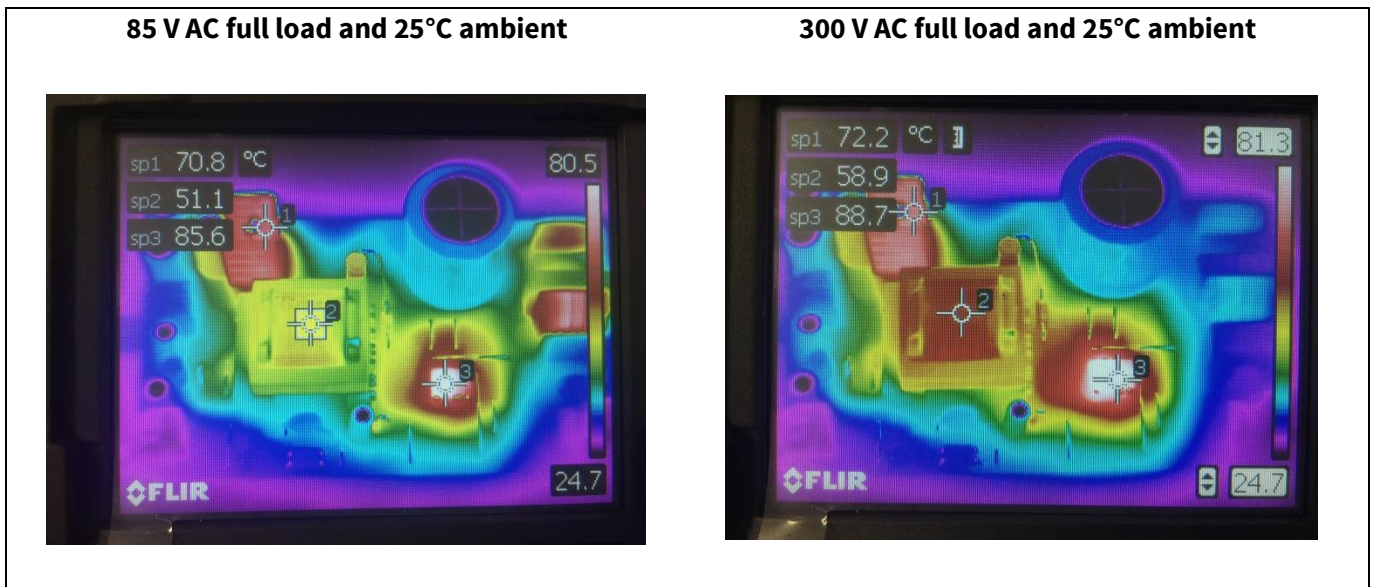

Figure 15 Infrared thermal image of DEMO\_5QR2270G

Waveforms and scope plots

## 11 Waveforms and scope plots

All waveforms and scope plots were recorded with a TELEDYNELECROY 606Zi oscilloscope.

### 11.1 Start-up at low/high AC-line input voltage with maximum load

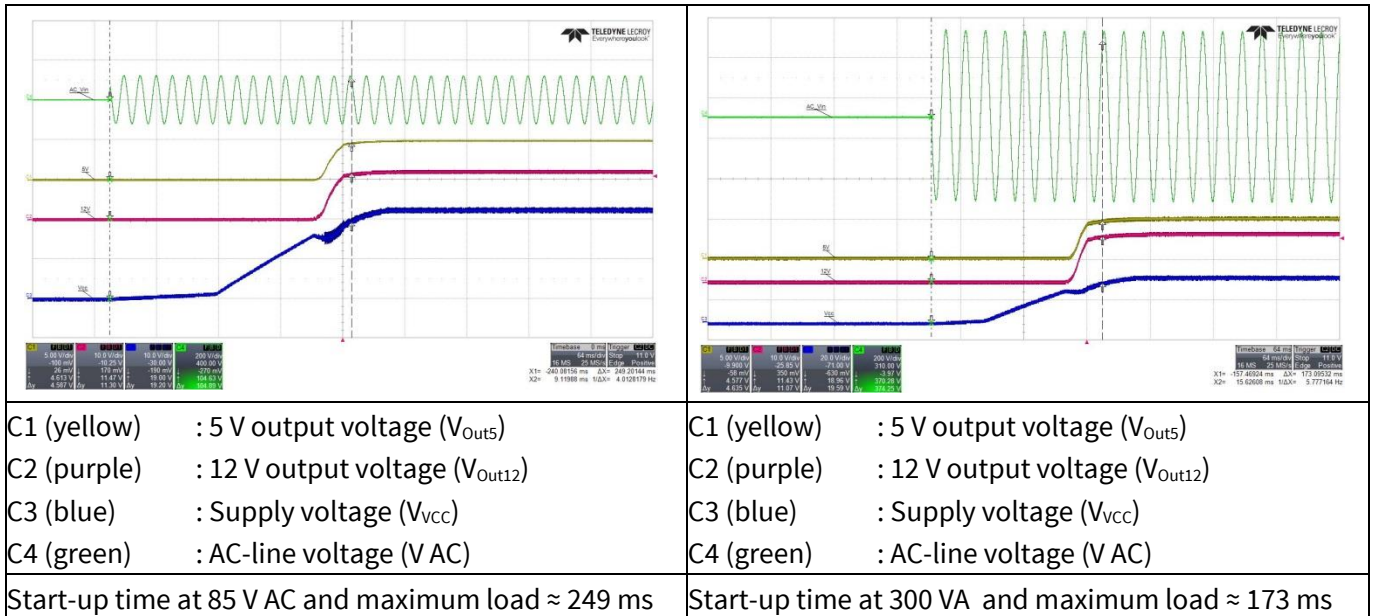

Figure 16 Start-up

### 11.2 Soft-start

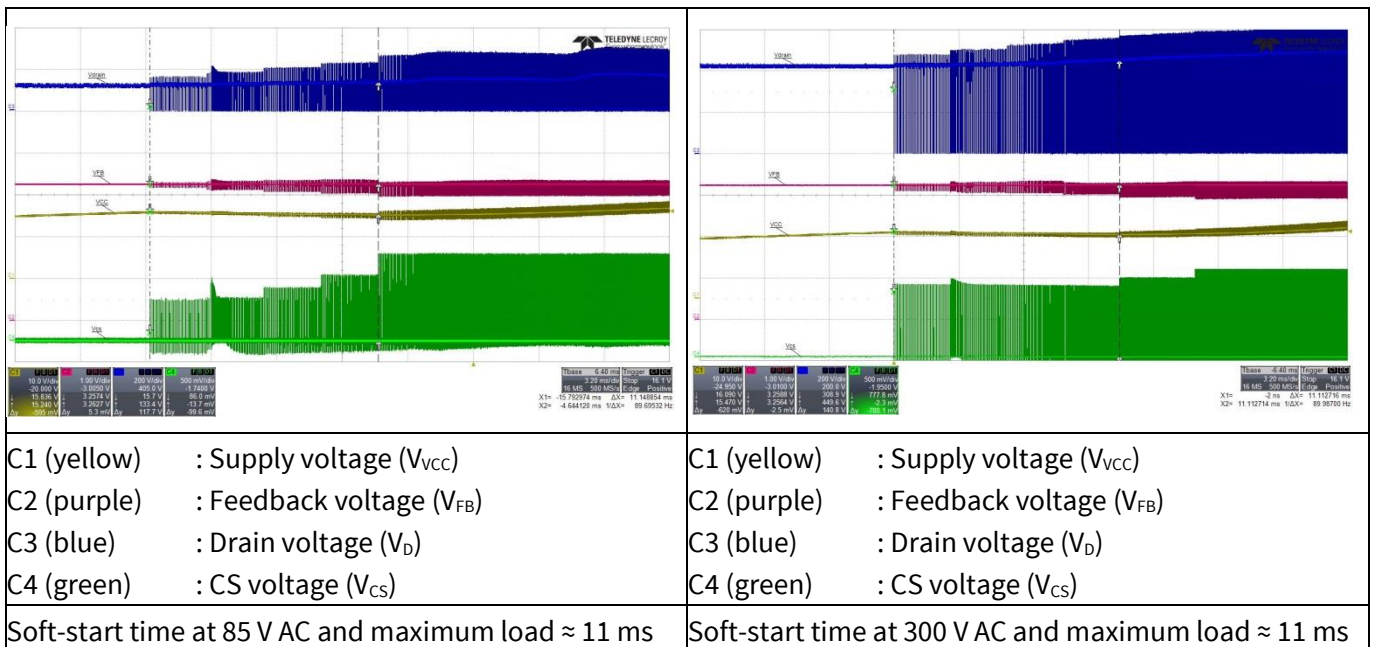

Figure 17 Soft-start

Waveforms and scope plots

11.3 Drain and CS voltage at maximum load

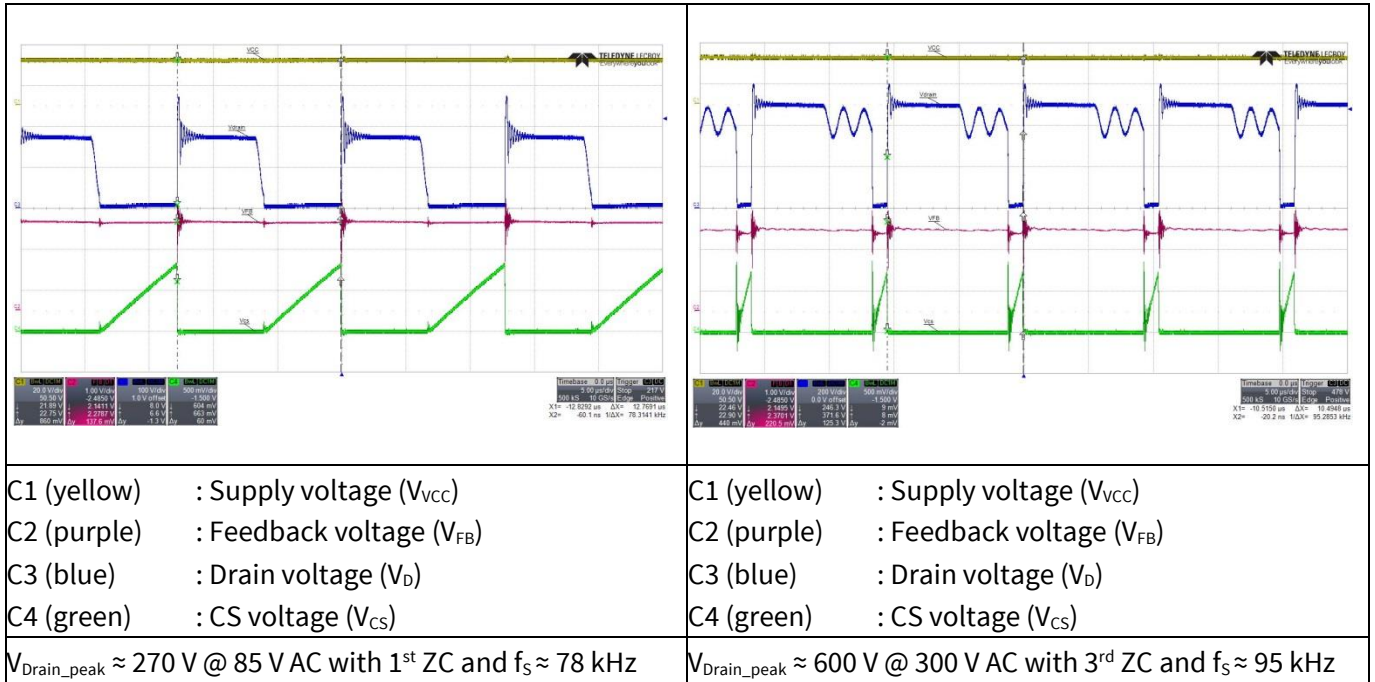

Figure 18 Drain and CS voltage at maximum load

11.4 Zero crossing point during normal operation

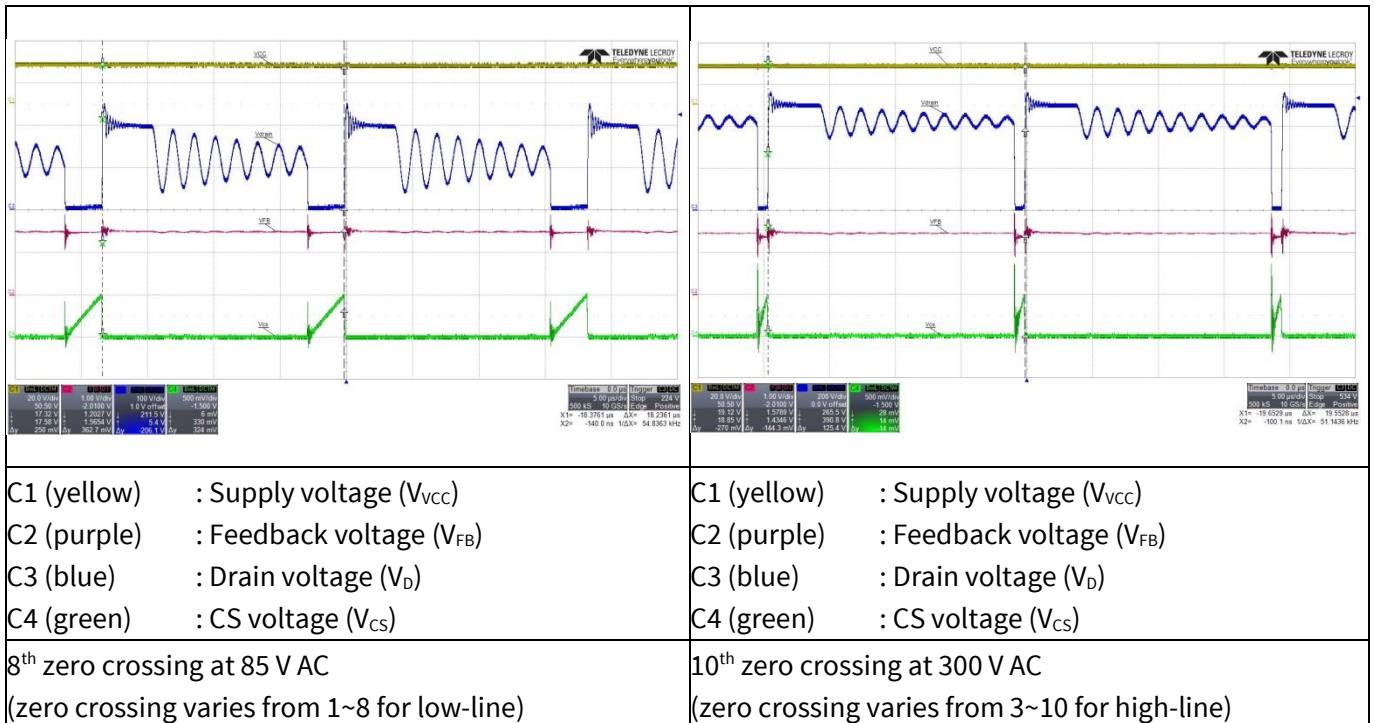

Figure 19 Zero crossing

Waveforms and scope plots

11.5 Load transient response (dynamic load from 10% to 100%)

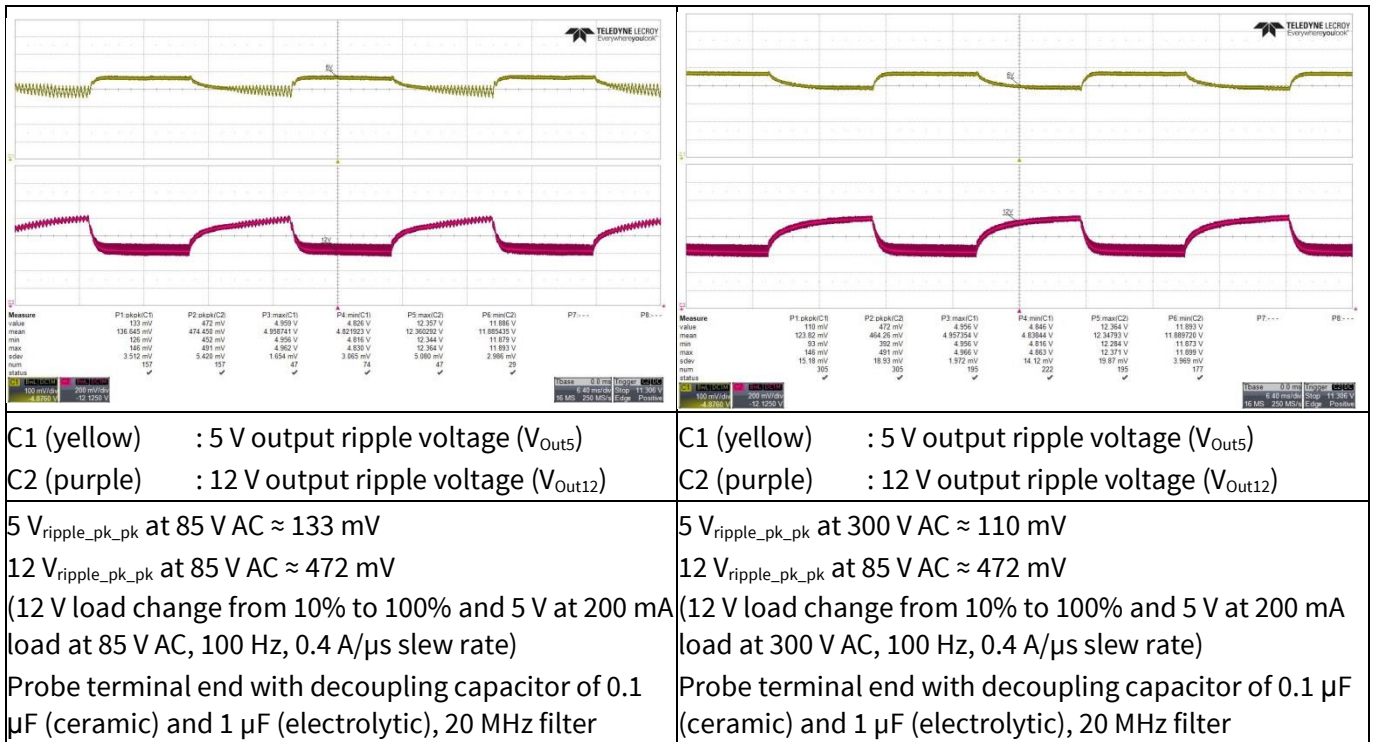

Figure 20 Load transient response

11.6 Output ripple voltage at maximum load

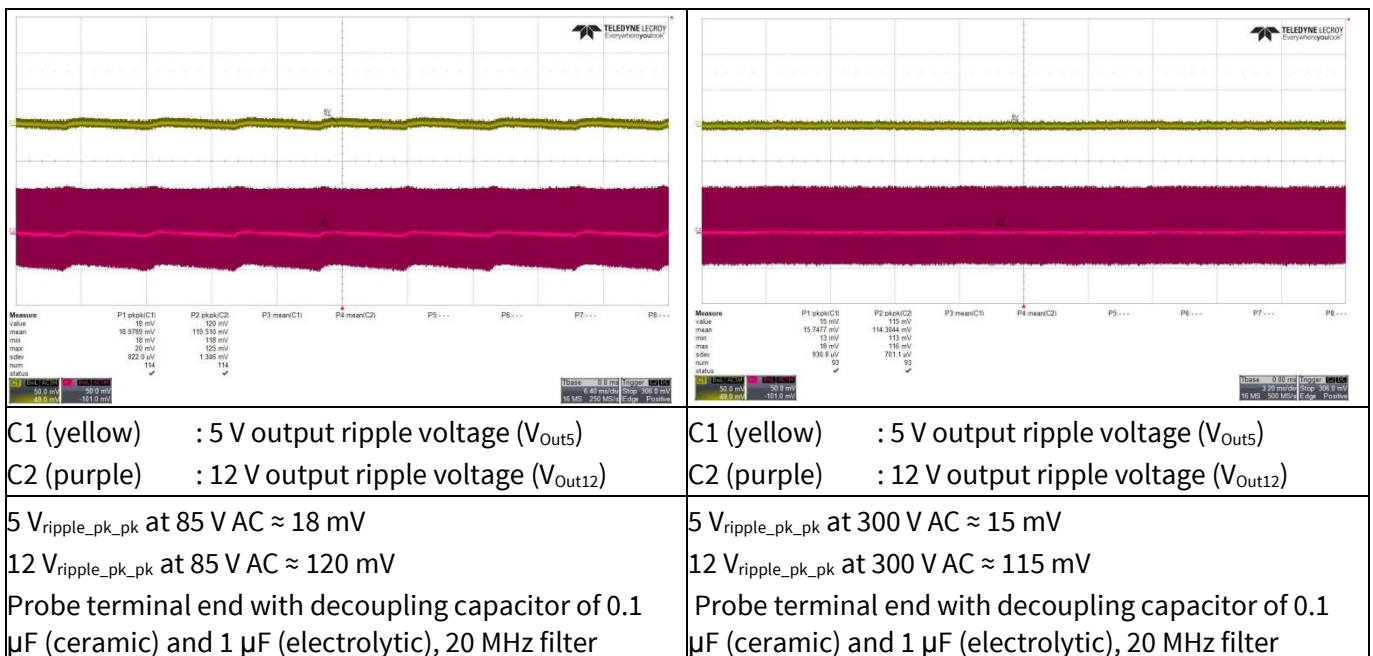

Figure 21 Output ripple voltage at maximum load



Waveforms and scope plots

11.7 Output ripple voltage at burst mode 1 W load

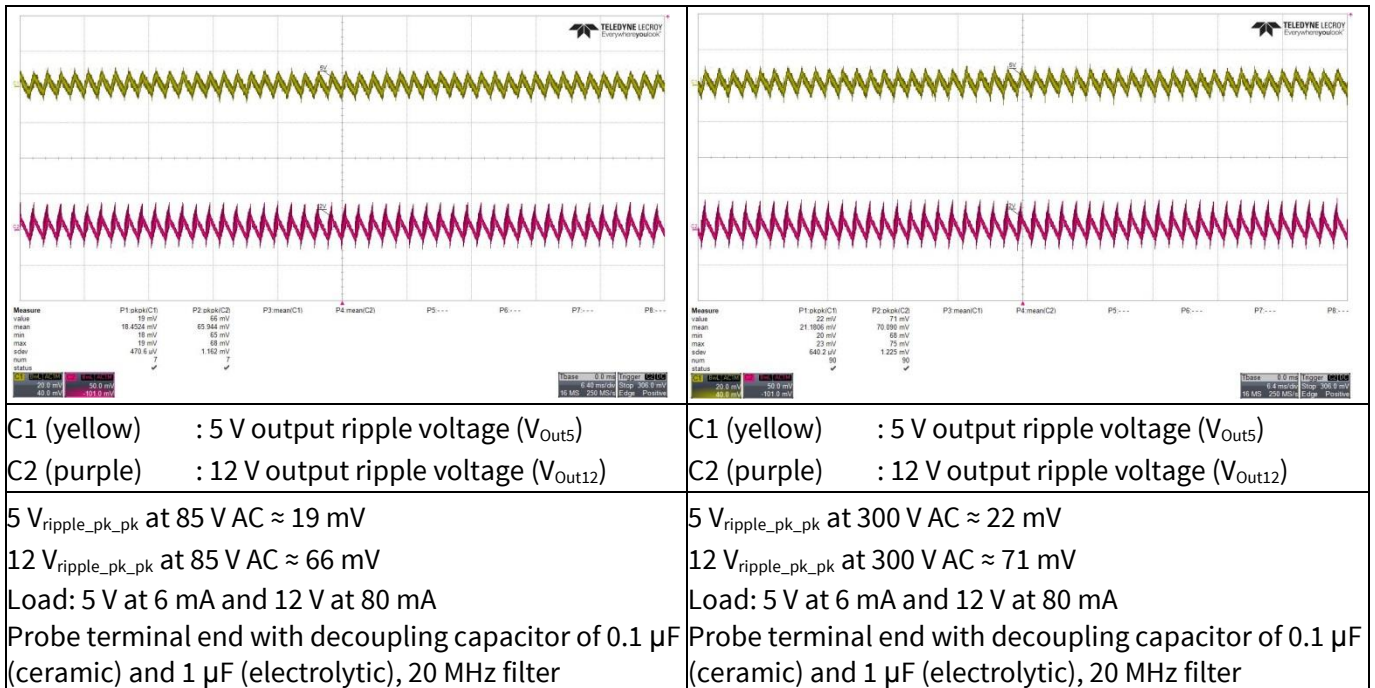

Figure 22 Output ripple voltage at burst mode 1 W load

11.8 Entering Active Burst Mode (ABM)

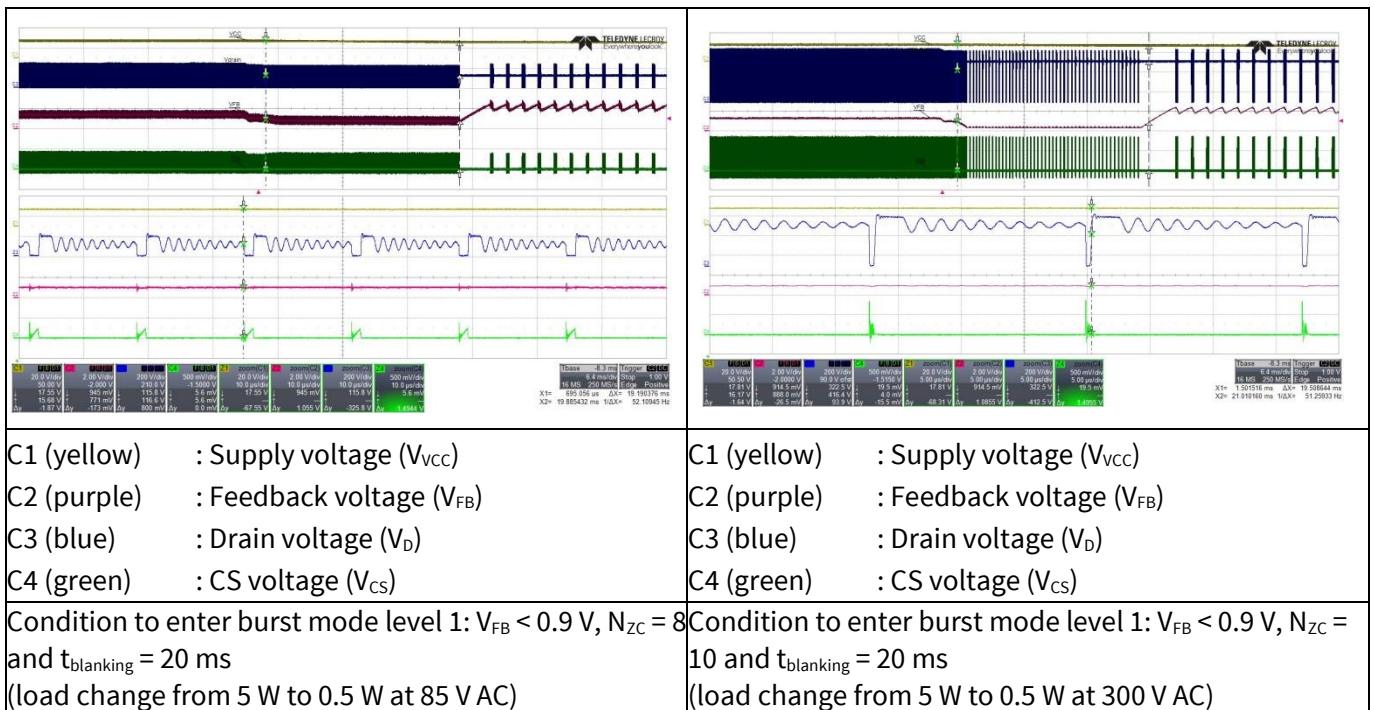

Figure 23 Entering Active Burst Mode (ABM)

Waveforms and scope plots

11.9 During Active Burst Mode (ABM)

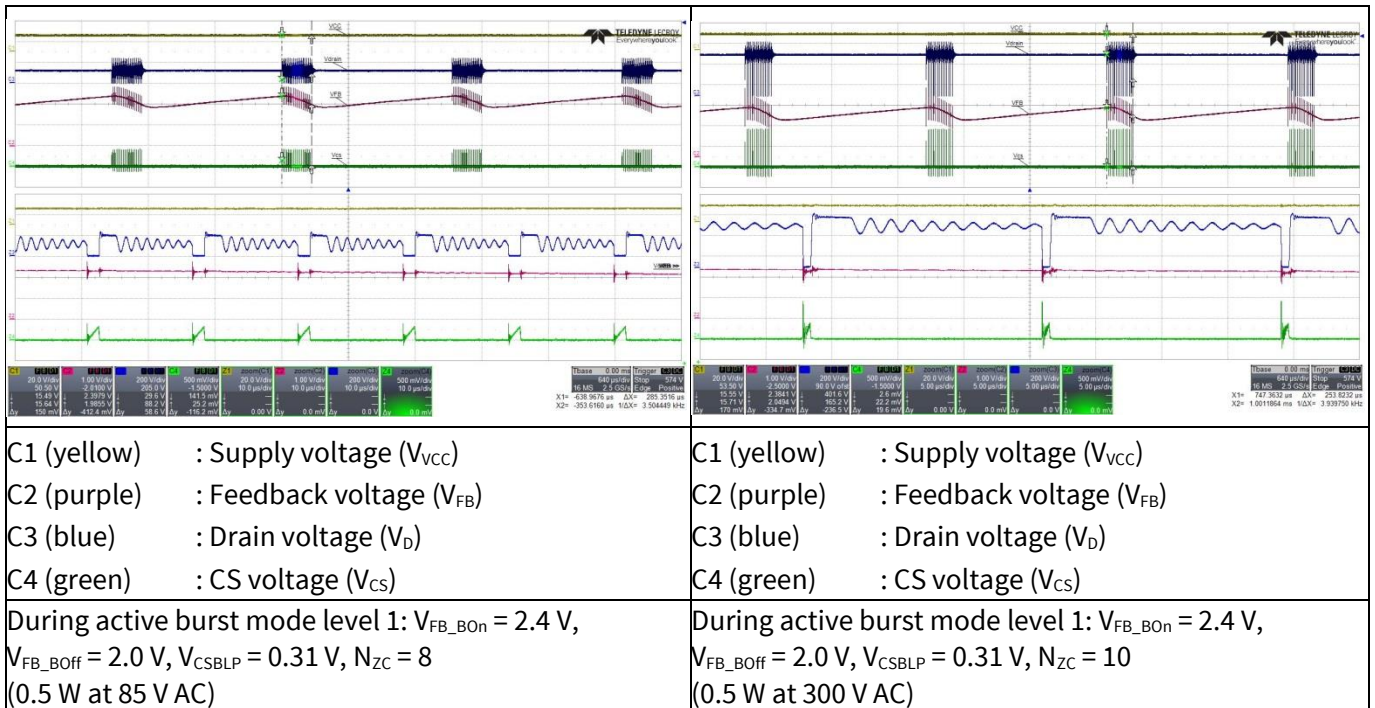

Figure 24 During Active Burst Mode (ABM)

11.10 Leaving Active Burst Mode (ABM)

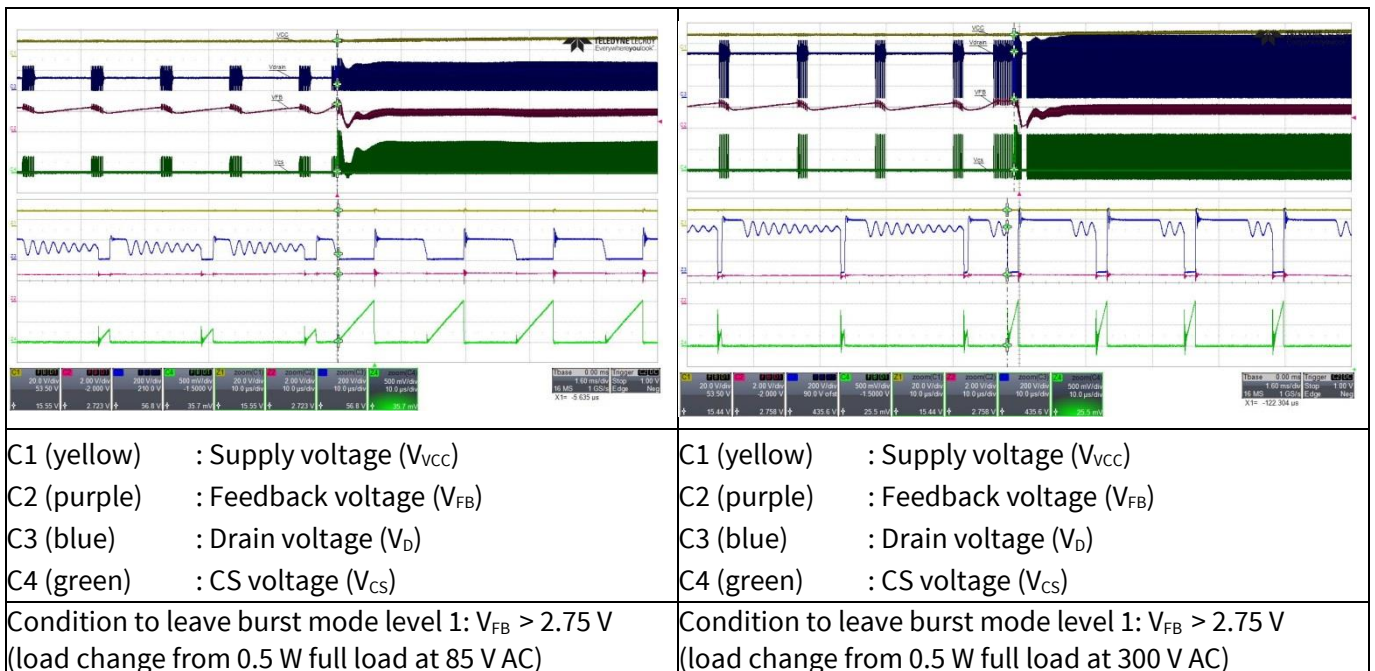

Figure 25 Leaving Active Burst Mode (ABM)

Waveforms and scope plots

11.11 Line OVP (non-switch auto restart)

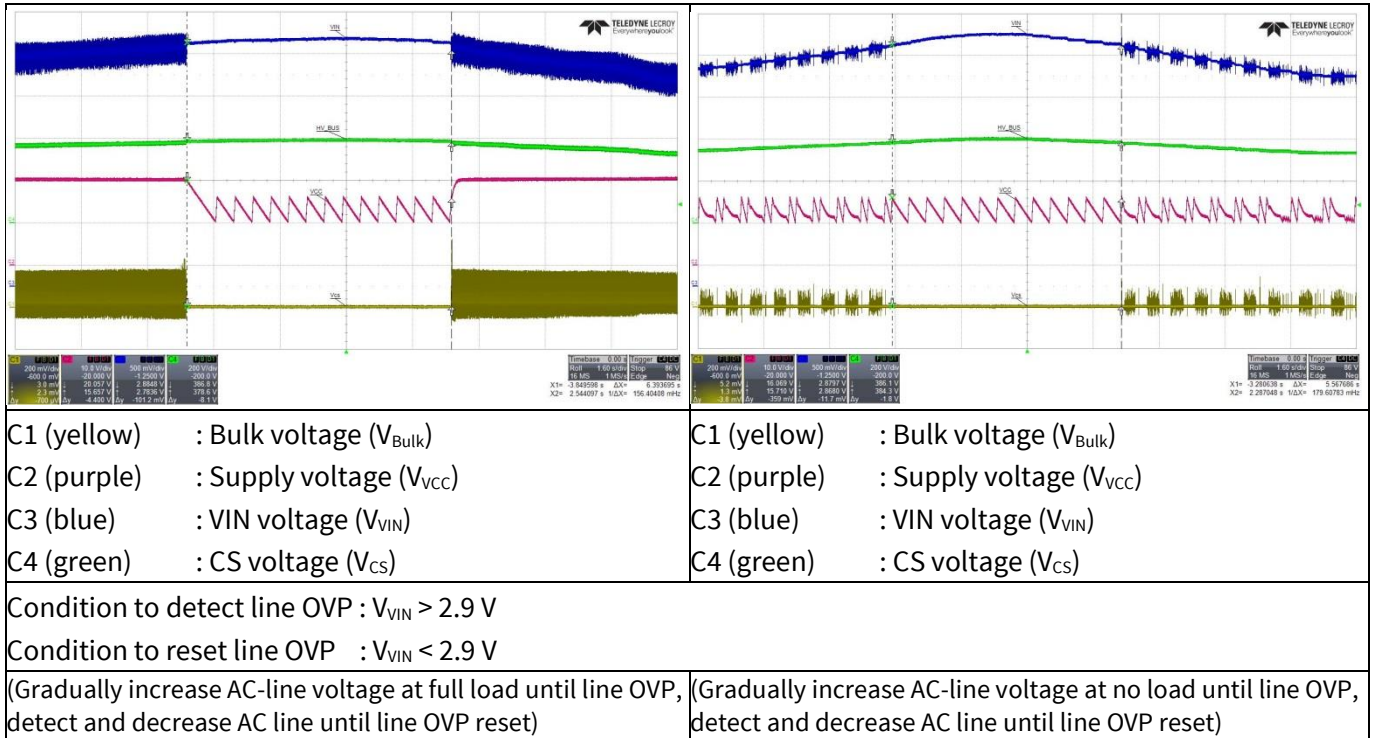

Figure 26 Line OVP

11.12 Brownout protection (non-switch auto restart)

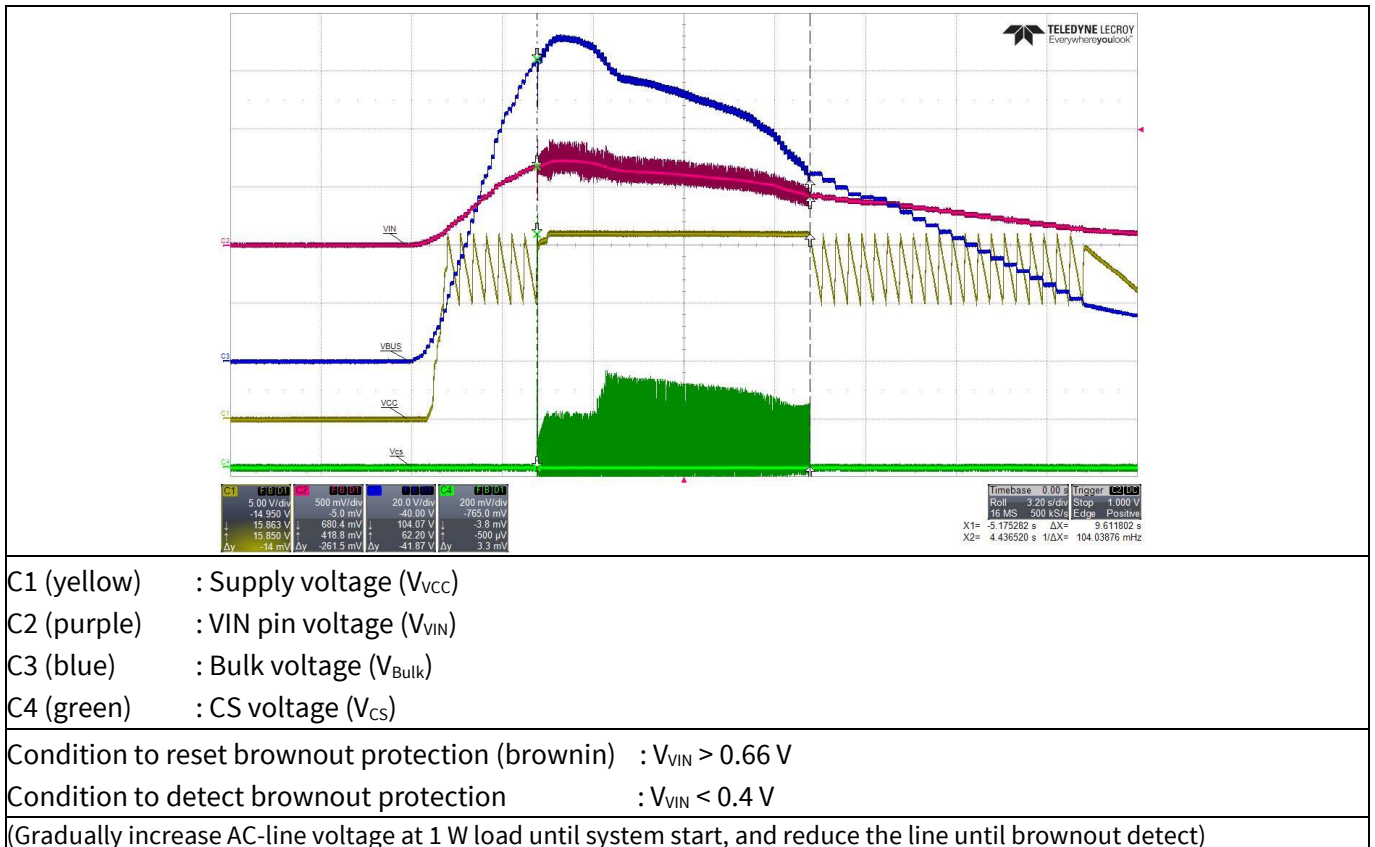
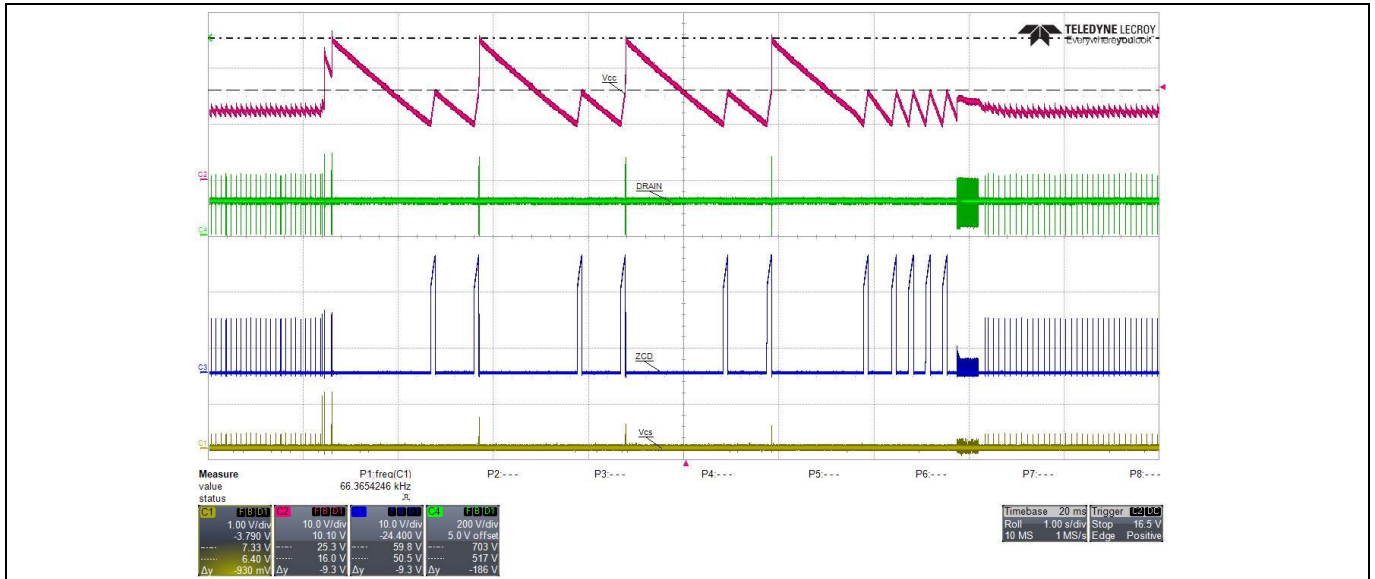

Figure 27 Brownout protection

Waveforms and scope plots

11.13  $V_{CC}$  OVP (odd-skip auto restart)



- C1 (yellow) : CS voltage ( $V_{CS}$ )
- C2 (purple) : Supply voltage ( $V_{VCC}$ )
- C3 (blue) : ZCD voltage ( $V_{ZCD}$ )
- C4 (green) : Drain voltage ( $V_D$ )

Condition to enter  $V_{CC}$  OVP:  $V_{VCC} > 25.5$  V  
 (85 V AC and disable ZCD pin output OVP detection, short R26)

Figure 28  $V_{CC}$  OVP

11.14  $V_{CC}$  under-voltage protection (auto restart)

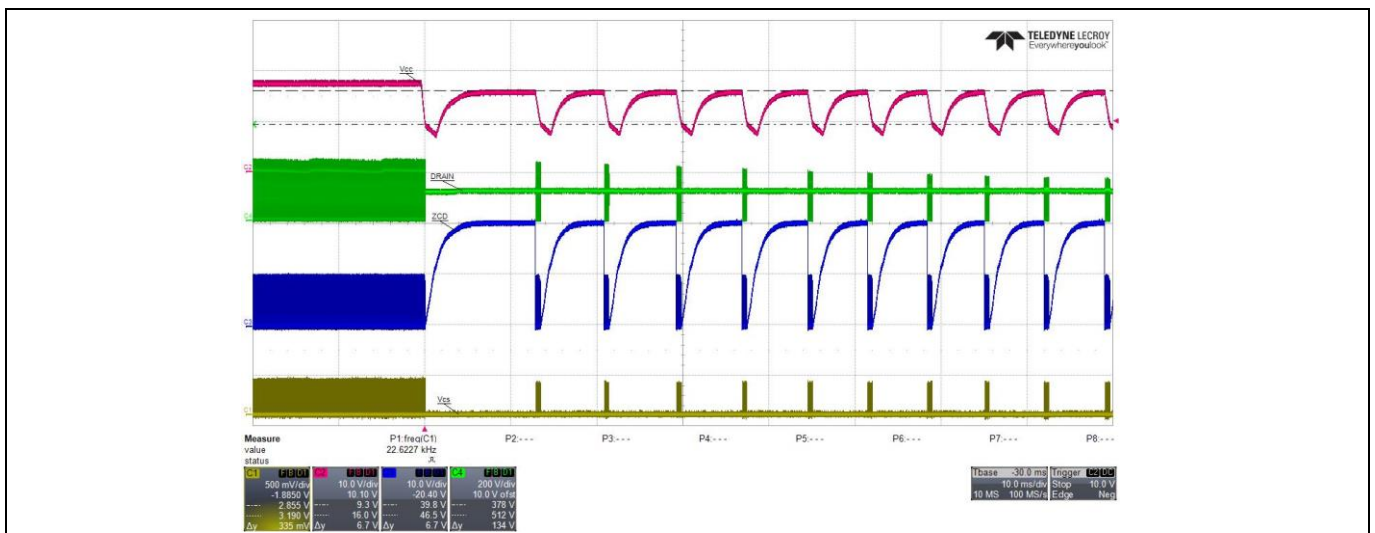

- C1 (yellow) : CS voltage ( $V_{CS}$ )
- C2 (purple) : Supply voltage ( $V_{VCC}$ )
- C3 (blue) : ZCD voltage ( $V_{ZCD}$ )
- C4 (green) : Drain voltage ( $V_D$ )

Condition to enter  $V_{CC}$  under voltage protection:  $V_{VCC} < 10$  V  
 (Remove R12A during normal operation @ 85 V AC)

Figure 29  $V_{CC}$  under-voltage protection

Waveforms and scope plots

11.15 Over-load protection (odd-skip auto restart)

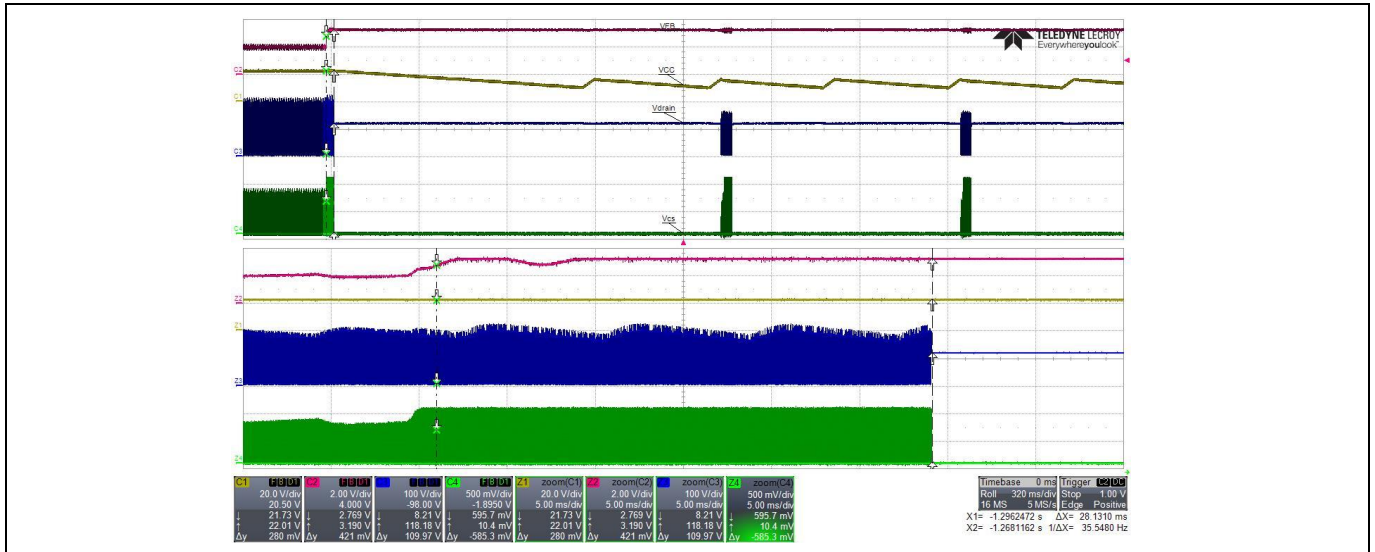

- C1 (yellow) : Supply voltage ( $V_{CC}$ )
- C2 (purple) : Feedback voltage ( $V_{FB}$ )
- C3 (blue) : Drain voltage ( $V_D$ )
- C4 (green) : CS voltage ( $V_{CS}$ )

Condition to enter over-load protection:  $V_{FB} > 2.75\text{ V}$  and lasts for 30 ms blanking time (12 V output load change from full load to short at 85 V AC)

Figure 30 Over load protection

11.16 Output OVP (odd-skip auto restart)

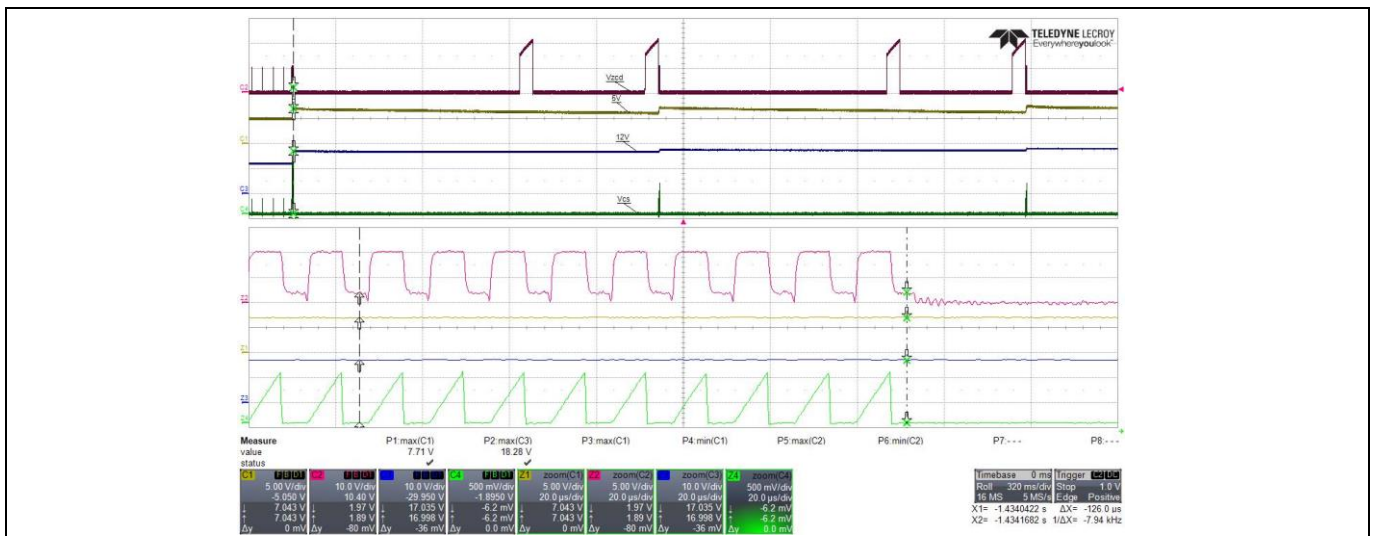

- C1 (yellow) : 5 V output voltage ( $V_{O5}$ )
- C2 (purple) : ZCD voltage ( $V_{ZCD}$ )
- C3 (blue) : 12 V output voltage ( $V_{O12}$ )
- C4 (green) : CS voltage ( $V_{CS}$ )

Condition to enter output OVP:  $V_{O12} > 17\text{ V}$ ,  $V_{O12} > 7\text{ V}$  ( $V_{ZCD} > 2\text{ V}$ ) (85 V AC, short R26 during system operation at no-load)

Figure 31 Output OVP

Waveforms and scope plots

11.17 V<sub>CC</sub> short-to-GND protection

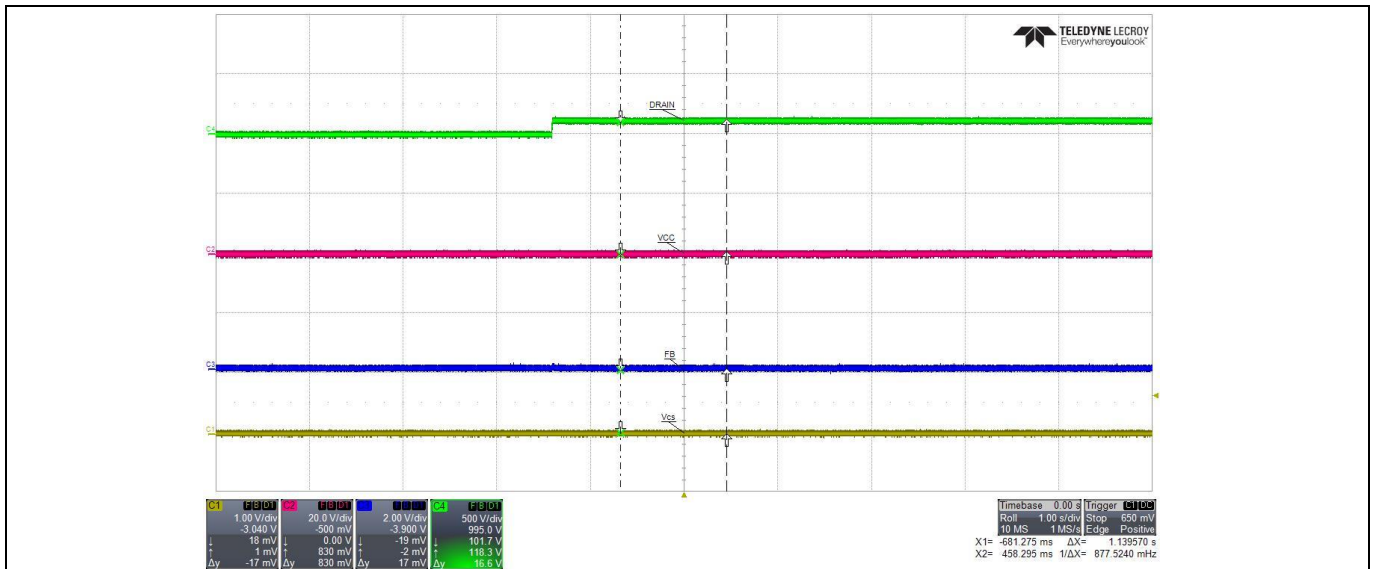

- C1 (yellow) : CS voltage (V<sub>CS</sub>)
- C2 (purple) : V<sub>CC</sub> voltage (V<sub>VCC</sub>)
- C3 (blue) : Feedback voltage (V<sub>FB</sub>)
- C4 (green) : Drain voltage (V<sub>D</sub>)

Condition to enter V<sub>CC</sub> short-to-GND: if  $V_{CC} < V_{VCC\_SCP} \Rightarrow I_{VCC} = I_{VCC\_charge1}$   
 (Short V<sub>CC</sub> pin to GND by multi-meter and measure the current, I<sub>VCC</sub> ≈ 280 μA and input power is ≈ 52 mW at 85 V AC and full load)

Figure 32 V<sub>CC</sub> short-to-GND protection

---

References

## 12 References

- [1] [ICE5QRxxxxAx datasheet, Infineon Technologies AG](#)
- [2] [AN-201609 PL83 026-5<sup>th</sup>-Generation Quasi-Resonant Design Guide](#)
- [3] [Calculation Tool Quasi Resonant CoolSET™ Generation 5](#)

---

**Revision history****Revision history**

<b>Document version</b>	<b>Date of release</b>	<b>Description of changes</b>
1.4	2023-01-19	Editorial changes
1.3	2018-09-12	Typos fixed
1.2	2018-04-26	Editorial changes
1.1	2017-06-21	Spelling error corrected
1.0	2017-05-24	Initial release



**Trademarks**

All referenced product or service names and trademarks are the property of their respective owners.

**Edition 2023-01-19**

**Published by**

**Infineon Technologies AG**

**81726 Munich, Germany**

**© 2023 Infineon Technologies AG.**

**All Rights Reserved.**

**Do you have a question about this document?**

**Email: [erratum@infineon.com](mailto:erratum@infineon.com)**

**Document reference**

**AN\_201609\_PL83\_028**

**IMPORTANT NOTICE**

The information contained in this application note is given as a hint for the implementation of the product only and shall in no event be regarded as a description or warranty of a certain functionality, condition or quality of the product. Before implementation of the product, the recipient of this application note must verify any function and other technical information given herein in the real application. Infineon Technologies hereby disclaims any and all warranties and liabilities of any kind (including without limitation warranties of non-infringement of intellectual property rights of any third party) with respect to any and all information given in this application note.

The data contained in this document is exclusively intended for technically trained staff. It is the responsibility of customer's technical departments to evaluate the suitability of the product for the intended application and the completeness of the product information given in this document with respect to such application.

For further information on the product, technology, delivery terms and conditions and prices please contact your nearest Infineon Technologies office ([www.infineon.com](http://www.infineon.com)).

**WARNINGS**

Due to technical requirements products may contain dangerous substances. For information on the types in question please contact your nearest Infineon Technologies office.

Except as otherwise explicitly approved by Infineon Technologies in a written document signed by authorized representatives of Infineon Technologies, Infineon Technologies' products may not be used in any applications where a failure of the product or any consequences of the use thereof can reasonably be expected to result in personal injury.