

Low noise amplifier for remote keyless entry (RKE) applications

RF low-power transistor

About this document

Scope and purpose

This application note provides an application circuit design example with Infineon's radio frequency (RF) low-power silicon (Si) transistor [BFP460](#) as low noise amplifier (LNA) for RKE automotive applications. In this document, the [BFP460](#) LNA schematic, PCB layout and measurement results are shown.

Intended audience

This document is intended for engineers who need to design RF LNAs for RKE applications.

Table of contents

About this document	1
Table of contents	1
1 Introduction	2
1.1 RKE for automotive applications.....	2
1.2 Infineon low-noise Si transistors	2
2 BFP460 LNA for RKE applications	3
2.1 Performance overview	3
2.2 Schematic.....	3
2.3 Bill of materials (BOM)	4
2.4 Evaluation board and layout information.....	4
3 Measurement results of BFP460 LNA for RKE applications	6
4 Author	11
Revision history	12

1 Introduction

1.1 RKE for automotive applications

The term “RKE” refers to a lock that uses an electronic remote control as a key, which is activated by a handheld device. Widely used in automobiles, an RKE performs the functions of a standard car key without physical contact. When within a few meters of the car, pressing a button on the remote can lock or unlock the doors, and the remote may also perform other functions.

An RKE system consists of an RF transmitter in the keyfob (or key) that sends a signal to the on-board receiver in the vehicle, as shown in Figure 1. In automotive systems, the on-board RKE receiver antenna is usually placed in locations often dictated by cost and practical considerations and may result in increasing path loss and reducing the RKE system range. Furthermore, the antennas used in the RKE receivers typically have poor efficiency. Adding an external LNA between the receiver antenna and the RKE IC is the most cost-effective option to increase the range of the RKE system with minimal increase in power consumption. The wireless carrier frequency used for the RKE systems is 315 MHz in the US/Japan and 433.92 MHz (ISM band) in Europe.

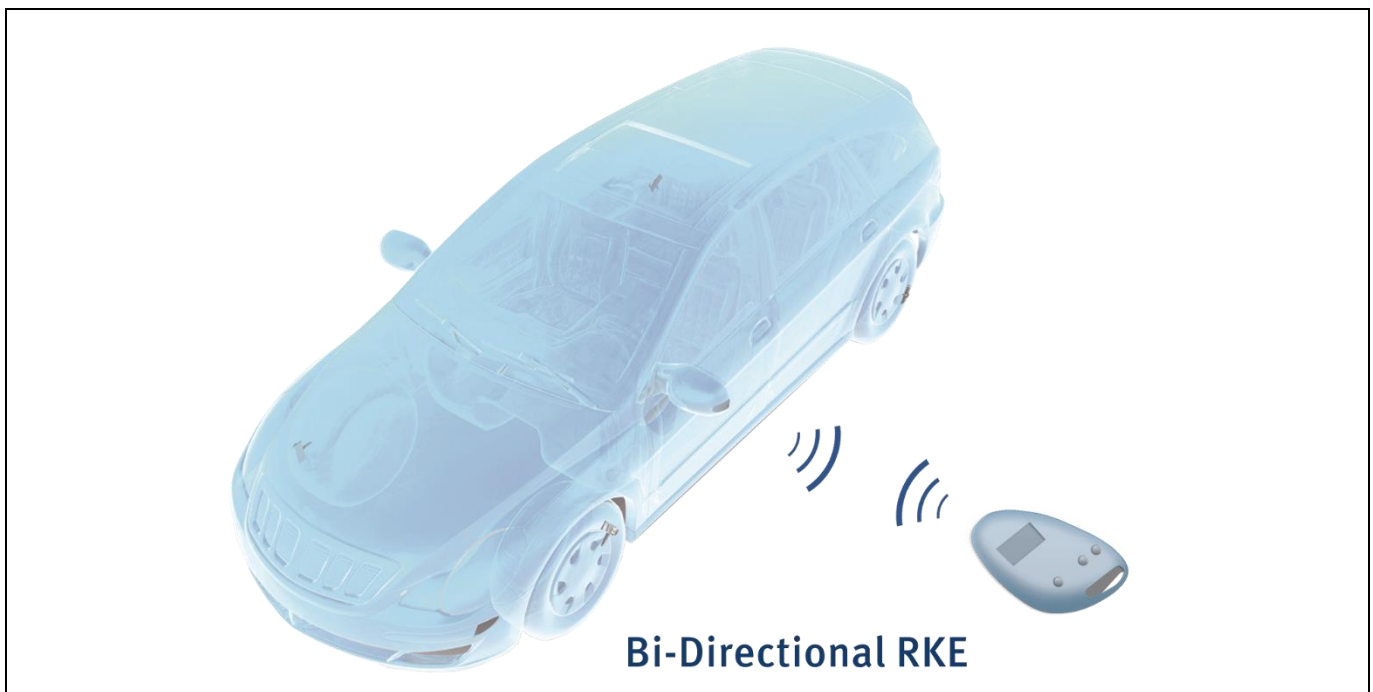

Figure 1 The RKE application in automobiles

1.2 Infineon low-noise Si transistors

Infineon Technologies provides high-performance RF transistors. Infineon’s reliable high-volume RF transistors offer exceptionally low noise figure (NF), high gain and high linearity at low power consumption levels for RF applications. The high-performance low-noise wide-band amplifiers are based on silicon bipolar technology. Their optimized inner transistor cell structure leads to best-in-class power gains and NF. The transistors maximize design flexibility to suit customer requirements.

2 BFP460 LNA for RKE applications

2.1 Performance overview

The following table shows the RF LNA performance with RF low-power transistor [BFP460](#) for RKE applications. The measurements are performed with network analyzer source power of -40 dBm.

Table 1 Summary of measurement results of [BFP460](#) LNA for RKE applications

Parameter	Symbol	Value			Unit	Notes
Bias voltage	V_{CC}	5.0			V	
Bias current	I_{CC}	5.3			mA	
Frequency range	f	315	434	900	MHz	
Gain	G	16.3	16	14.3	dB	
Input return loss	RL_{in}	16.4	14.2	10.3	dB	
Output return loss	RL_{out}	24.2	24.6	20.2	dB	
Reverse isolation	ISO_{rev}	21.1	21	20.6	dB	
Noise figure	NF	1.6	1.7	1.7	dB	PCB and SMA connector losses not extracted
Input 1 dB compression point	IP_{1dB}	-20.9 ¹⁾		-20.2 ²⁾	dBm	1) Measured at 315 MHz 2) Measured at 434 MHz
Output 1 dB compression point	OP_{1dB}	-5.6 ³⁾		-5.2 ⁴⁾	dBm	3) Measured at 315 MHz 4) Measured at 434 MHz
Output third-order intercept point	OIP_3	6.8 ⁵⁾		6.7 ⁶⁾	dBm	5) Input power: -33 dBm per tone, $f_1=314.5$ MHz, $f_2=315.5$ MHz 6) Input power: -33 dBm per tone, $f_1=433.5$ MHz, $f_2=434.5$ MHz
Stability	K	>1				Measured from 10 MHz up to 10 GHz

2.2 Schematic

The following figure shows the schematic of [BFP460](#) LNA for RKE applications. In the schematic, resistors R1, R2 and R3 stand for transistor voltage and current bias; meanwhile, R1 and R3 form a negative DC feedback mechanism to stabilize the transistor bias points in various conditions. R2 and C2 serve as the negative feedback to improve input and output impedance matching. Capacitors C3 and C4 serve as the RF bypass. The transistor input matching is achieved by C1. The output matching network is formed by C5 and R4.

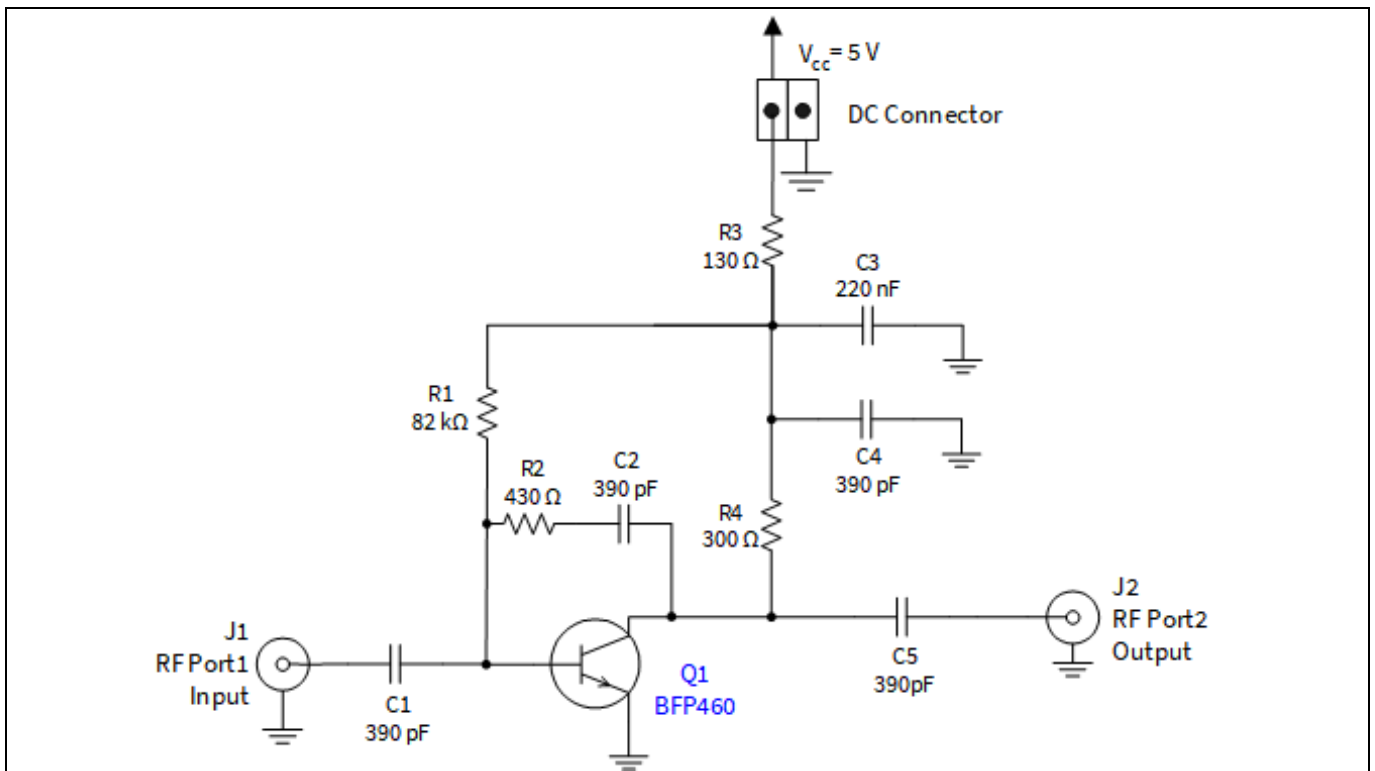

Figure 2 BFP460 LNA schematic for RKE applications

2.3 Bill of materials (BOM)

Table 2 BOM of BFP460 LNA for RKE applications

Symbol	Value	Unit	Package	Manufacture	Comment
Q1	BFP460		SOT343	Infineon	Low-power Si transistor
C1	390	pF	0402	various	DC block and input matching
C2	390	pF	0402	various	DC block for feedback network
C3	220	nF	0402	various	RF bypass
C4	390	pF	0402	various	RF bypass
C5	390	pF	0402	various	DC block and output matching
R1	82	kΩ	0402	various	Base DC bias
R2	430	Ω	0402	various	Feedback resistor
R3	130	Ω	0402	various	DC bias and DC negative feedback
R4	300	Ω	0402	various	Collector DC bias and output matching

2.4 Evaluation board and layout information

The evaluation board for [BFP460](#) LNA for RKE applications:

- PCB material: FR4
- PCB marking: BFP460 V2.0

Images of the evaluation board and the PCB stack information are shown in the following figures.

Low noise amplifier for remote keyless entry (RKE) applications

RF low-power transistor

BFP460 LNA for RKE applications

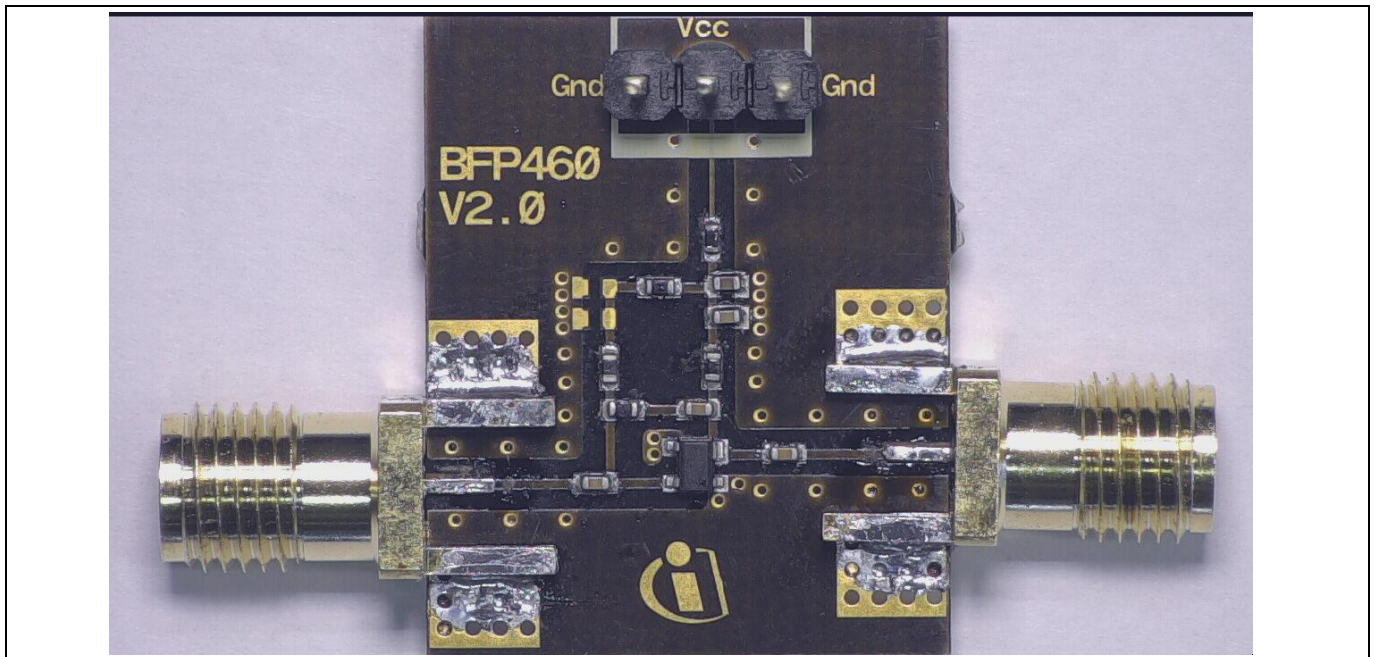

Figure 3 The photo of [BFP460](#) LNA for RKE applications

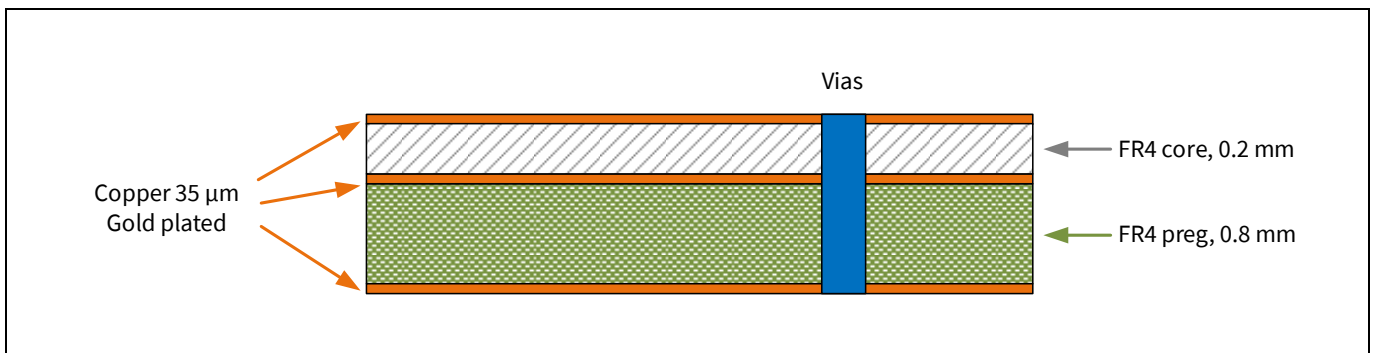

Figure 4 PCB stack information for the evaluation board

3 Measurement results of **BFP460** LNA for RKE applications

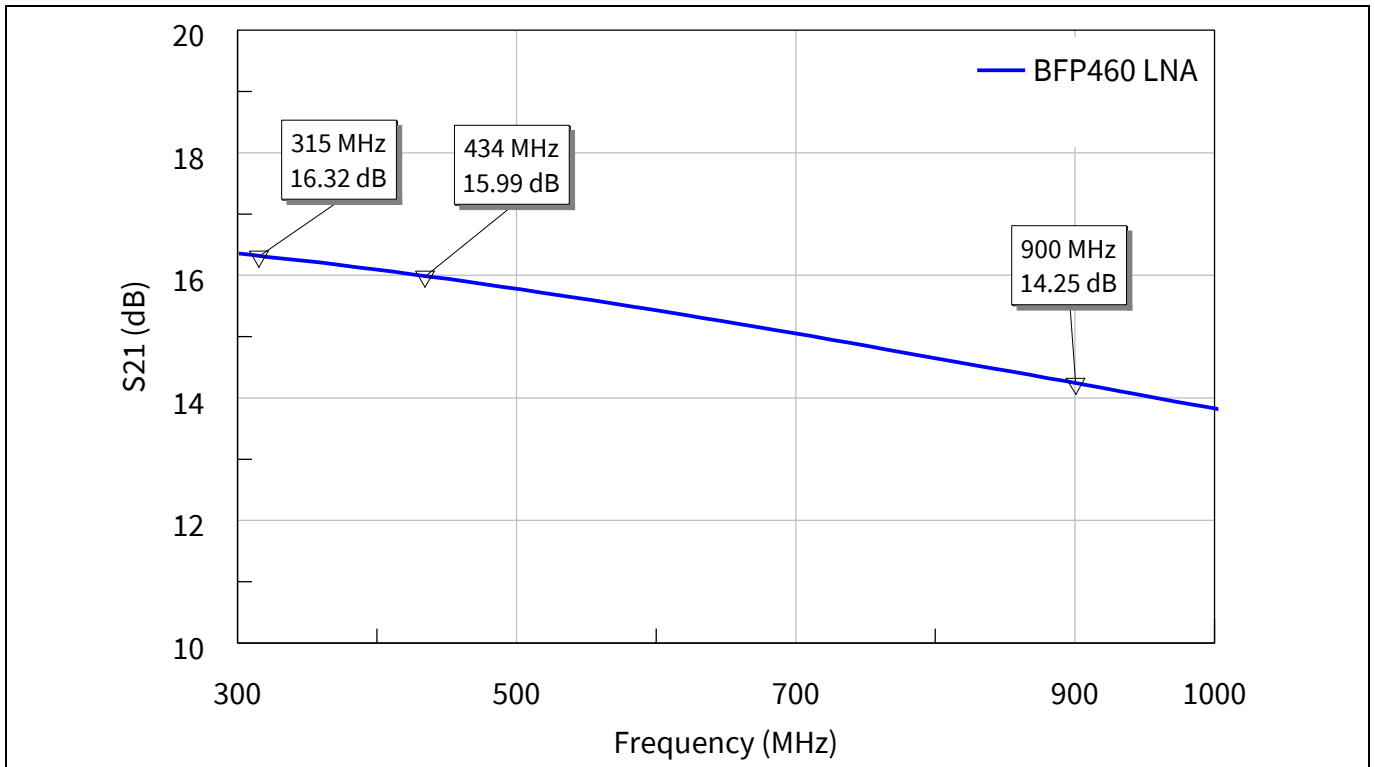

Figure 5 Small signal gain of **BFP460** LNA for RKE applications

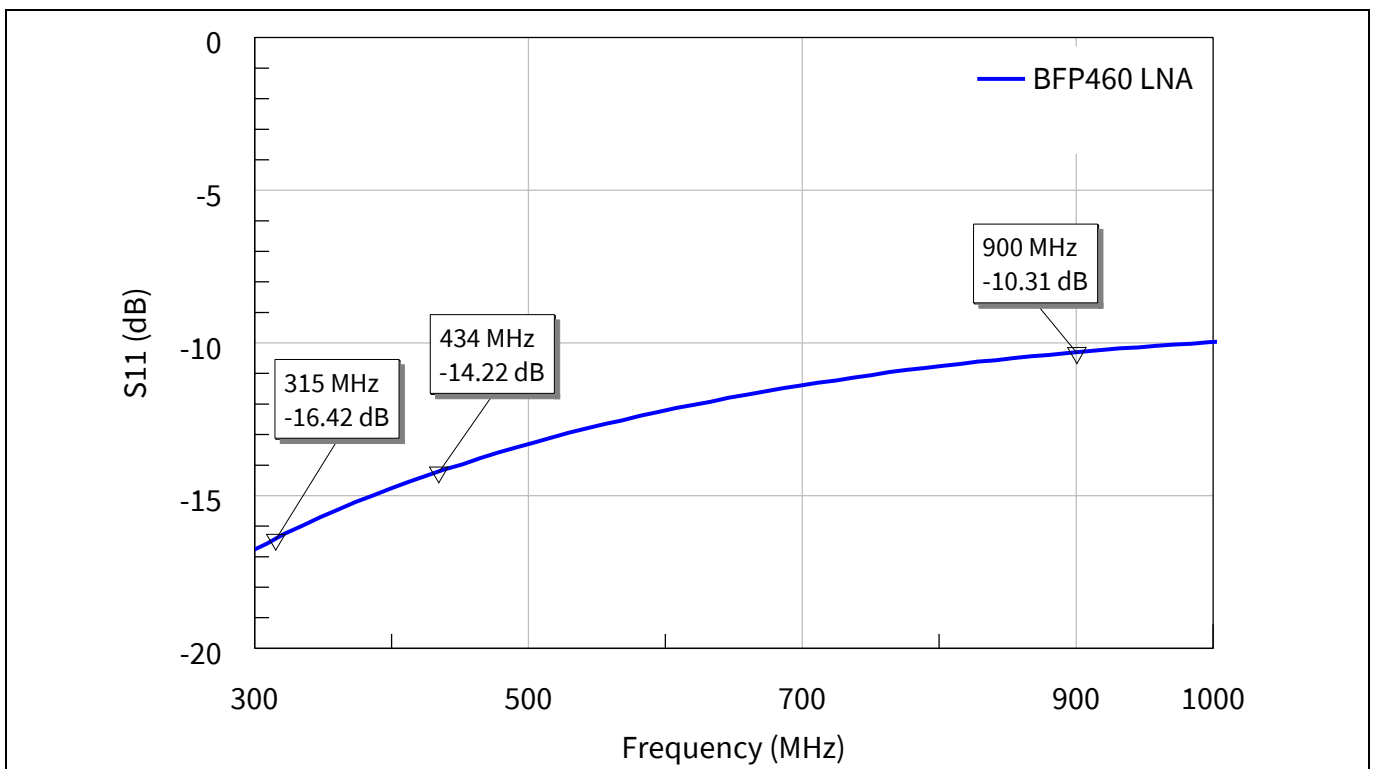

Figure 6 Input return loss of **BFP460** LNA for RKE applications

Note: The graphs are generated with the AWR electronic design automation (EDA) software Microwave Office®.

RF low-power transistor

Measurement results of BFP460 LNA for RKE applications

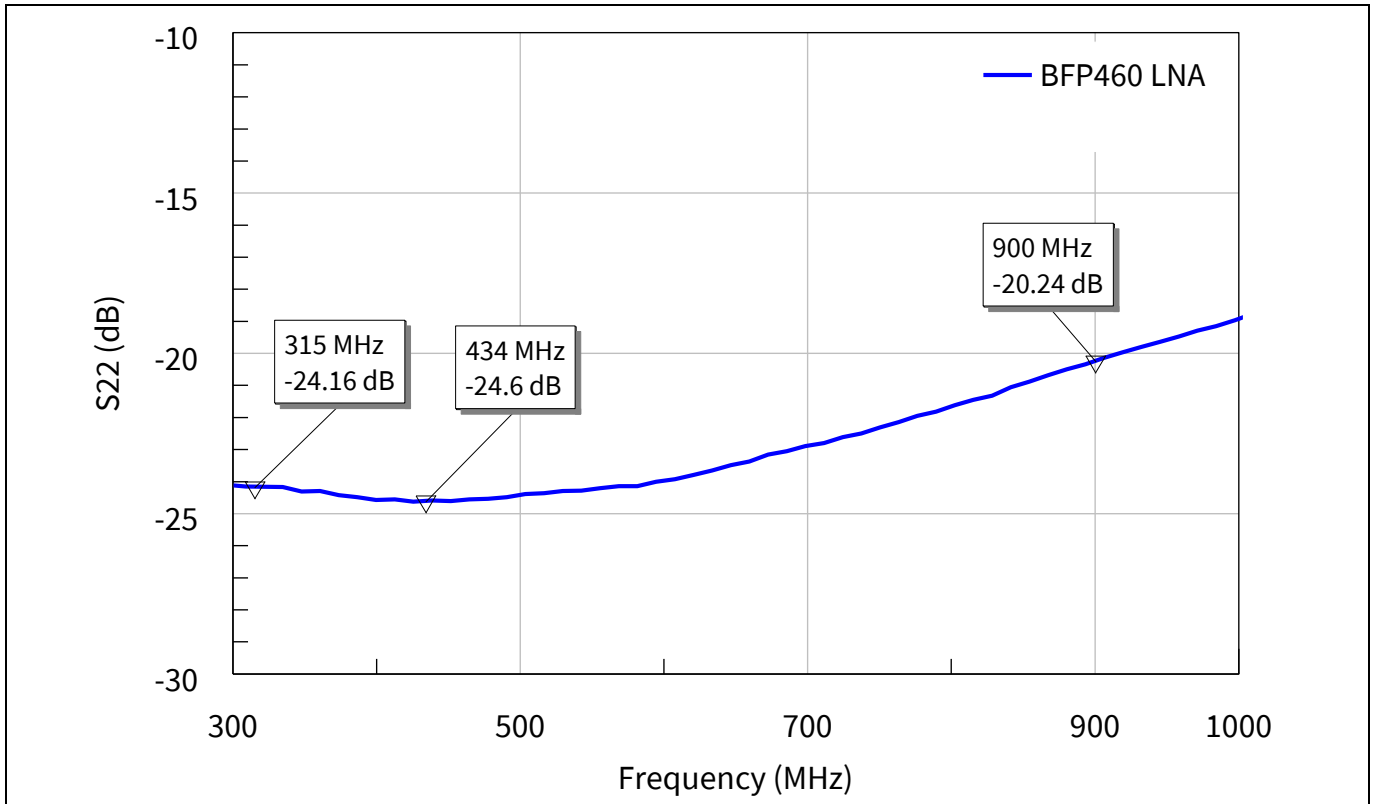

Figure 7 Output return loss of **BFP460** LNA for RKE applications

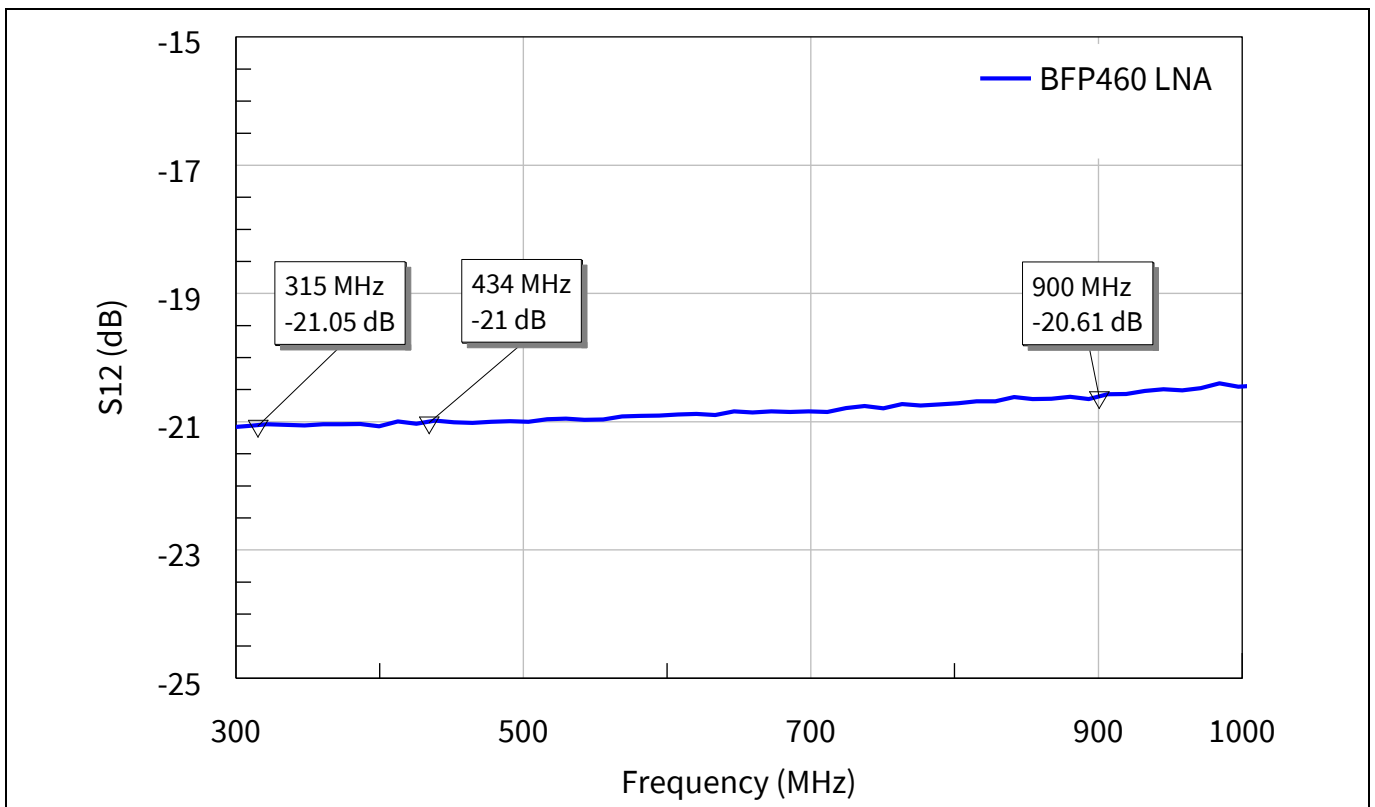

Figure 8 Reverse isolation of **BFP460** LNA for RKE applications

RF low-power transistor

Measurement results of BFP460 LNA for RKE applications

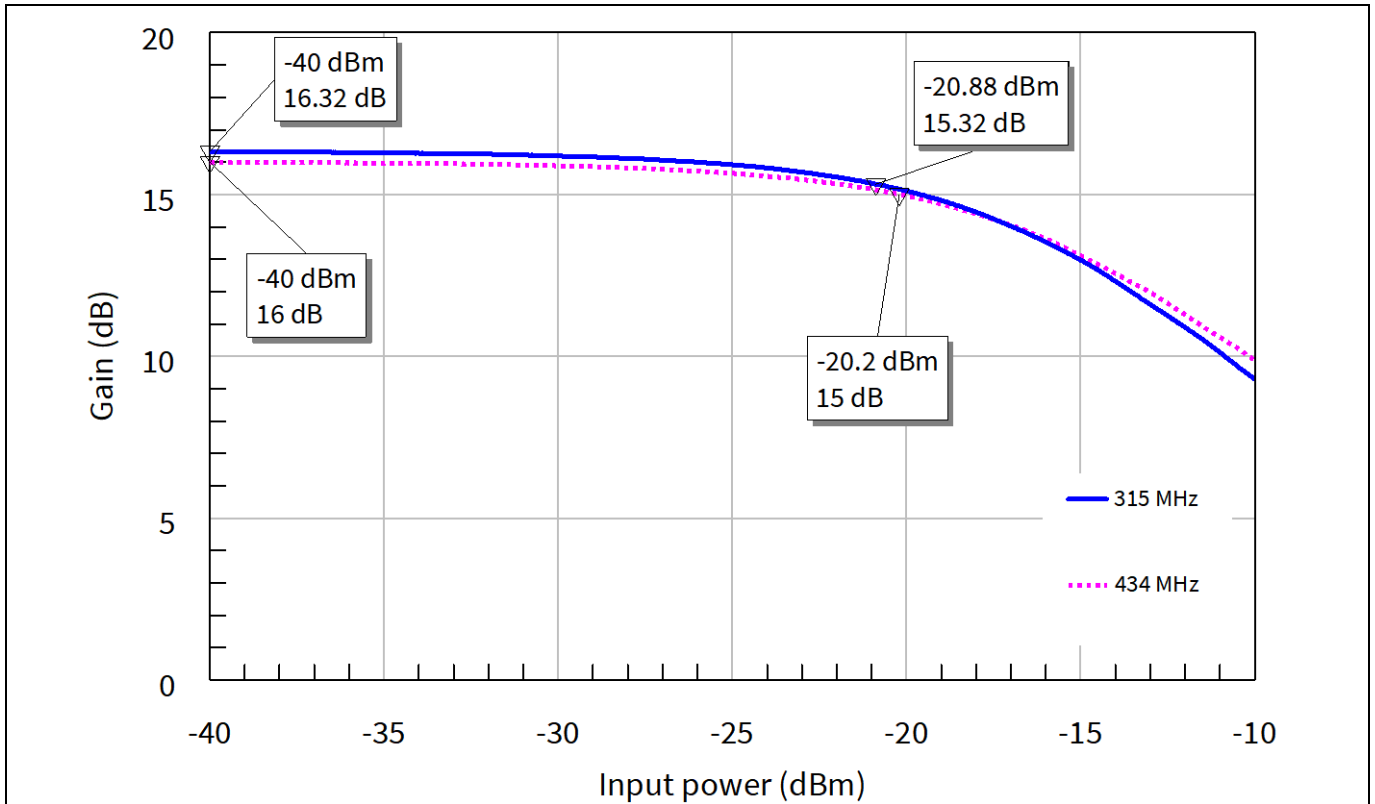

Figure 9 Input 1 dB compression point of **BFP460** LNA for RKE applications

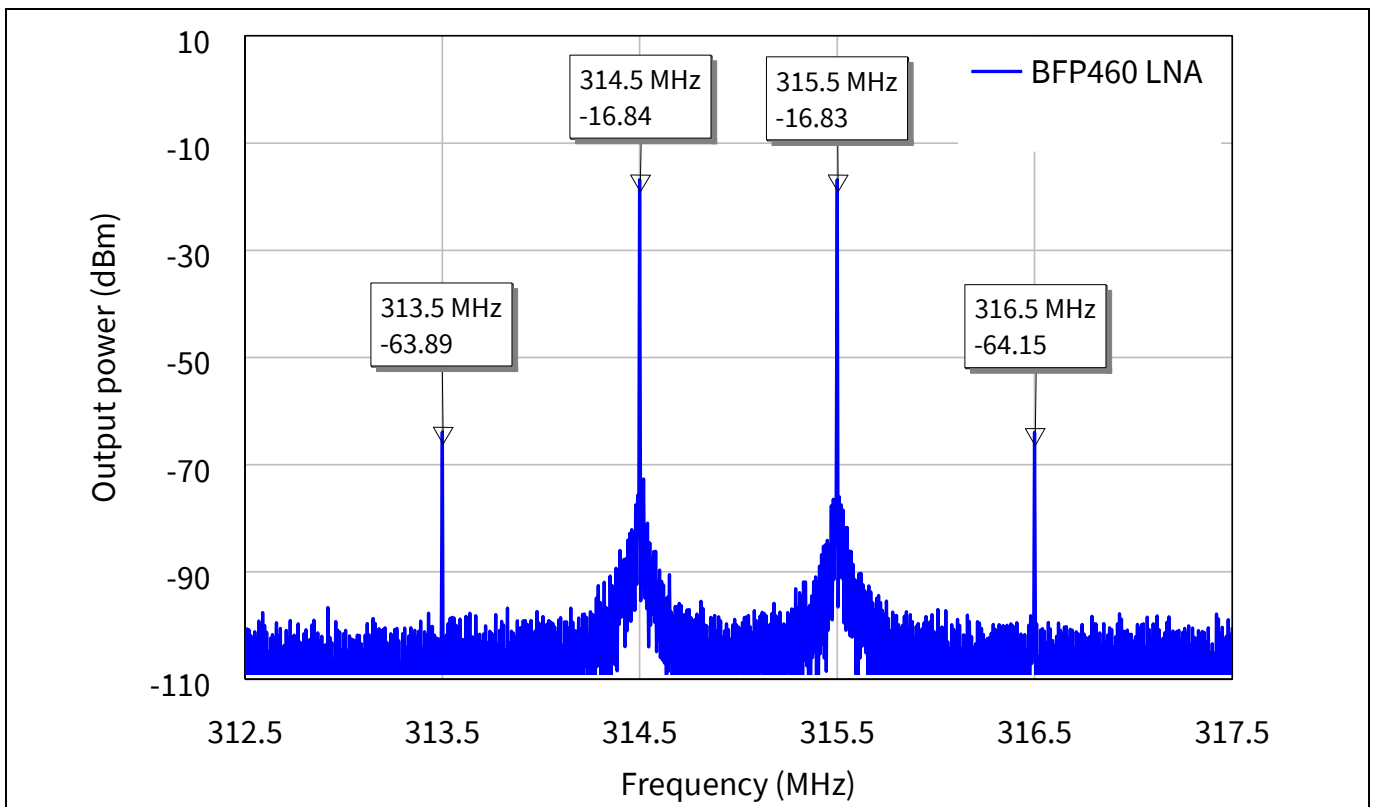

Figure 10 Output third-order intermodulation products of the **BFP460** LNA at 315 MHz with -33 dBm input power per tone for RKE applications

RF low-power transistor

Measurement results of BFP460 LNA for RKE applications

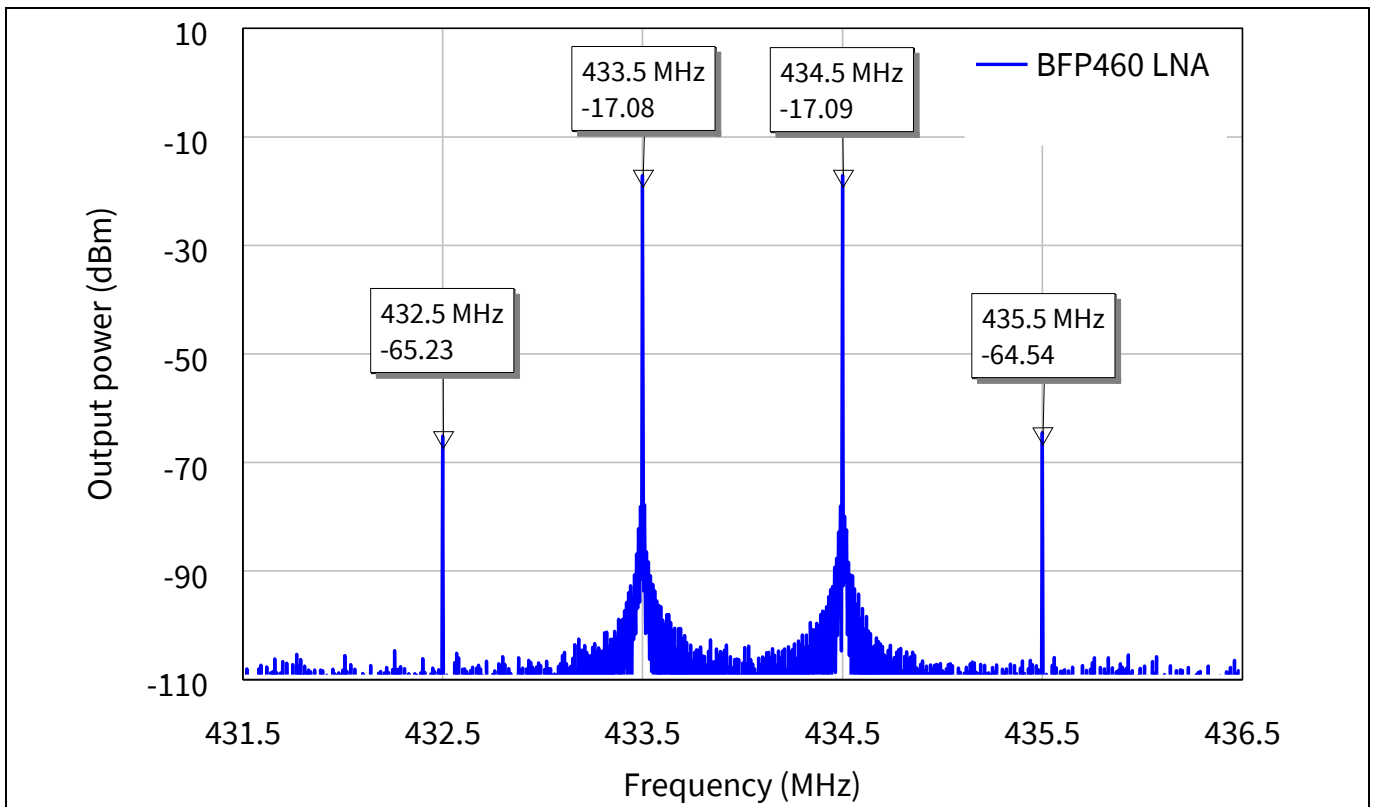

Figure 11 Output third-order intermodulation products of the [BFP460](#) LNA at 434 MHz with -33 dBm input power per tone for RKE applications

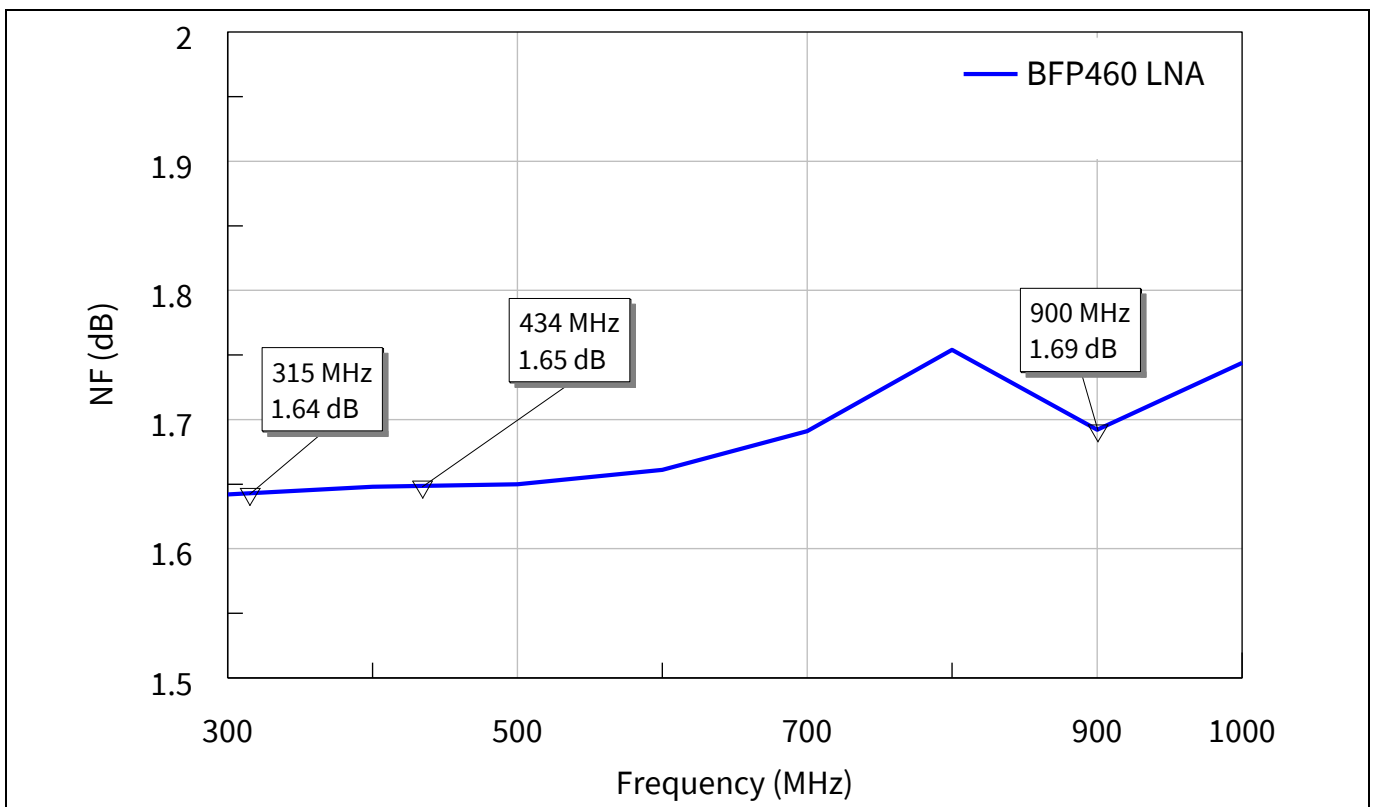

Figure 12 NF measurement of [BFP460](#) LNA for RKE applications

Low noise amplifier for remote keyless entry (RKE) applications

RF low-power transistor



Measurement results of BFP460 LNA for RKE applications

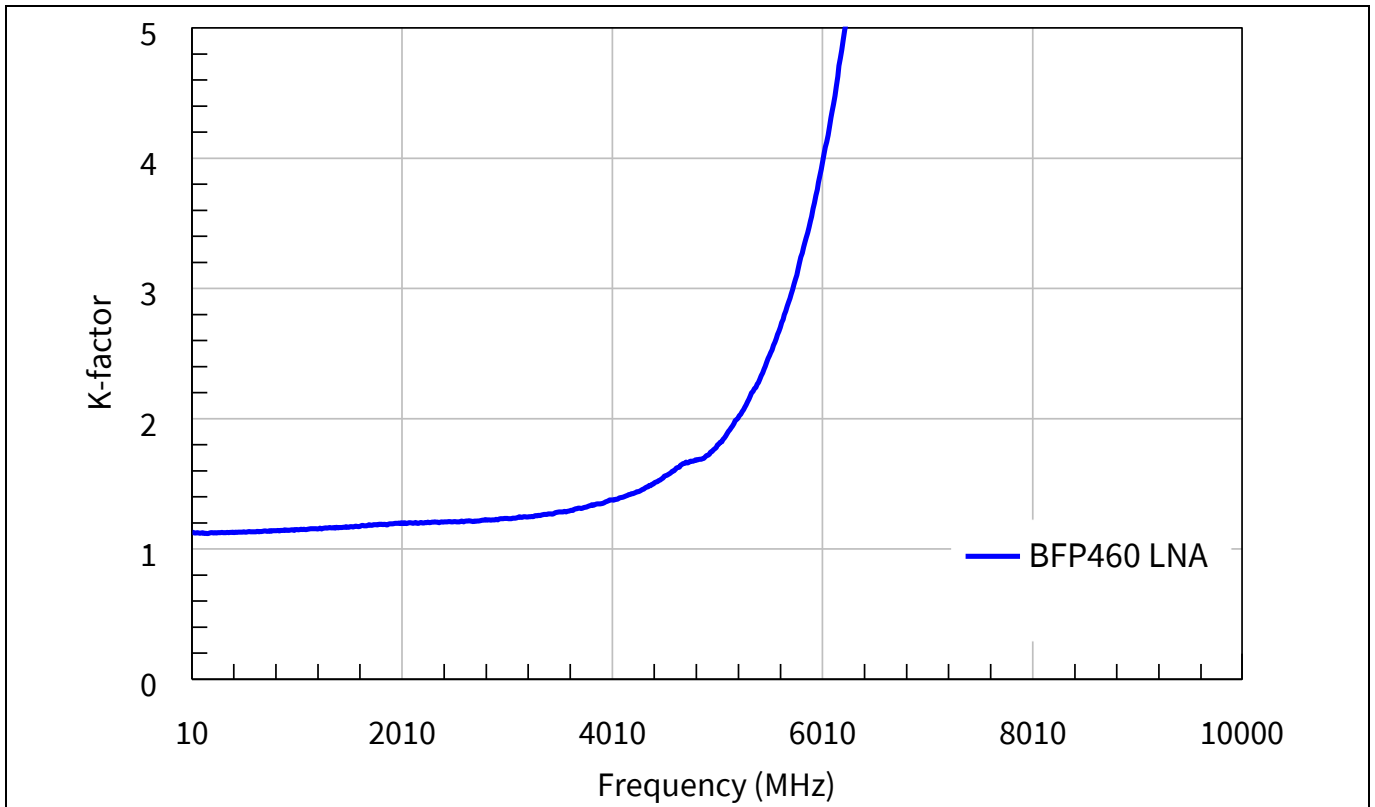

Figure 13 K-factor measurement of [BFP460](#) LNA for RKE applications

Author

4 Author

Atif Mehmood, RF application engineer of business unit RF and sensors.

Revision history

Revision history

Document version	Date of release	Description of changes

Trademarks

All referenced product or service names and trademarks are the property of their respective owners.

Edition 2018-08-21

Published by

Infineon Technologies AG

81726 Munich, Germany

© 2018 Infineon Technologies AG.

All Rights Reserved.

Do you have a question about this document?

Email: erratum@infineon.com

Document reference

AN_1808_PL32_1809_133505

IMPORTANT NOTICE

The information contained in this application note is given as a hint for the implementation of the product only and shall in no event be regarded as a description or warranty of a certain functionality, condition or quality of the product. Before implementation of the product, the recipient of this application note must verify any function and other technical information given herein in the real application. Infineon Technologies hereby disclaims any and all warranties and liabilities of any kind (including without limitation warranties of non-infringement of intellectual property rights of any third party) with respect to any and all information given in this application note.

The data contained in this document is exclusively intended for technically trained staff. It is the responsibility of customer's technical departments to evaluate the suitability of the product for the intended application and the completeness of the product information given in this document with respect to such application.

For further information on the product, technology, delivery terms and conditions and prices please contact your nearest Infineon Technologies office (www.infineon.com).

WARNINGS

Due to technical requirements products may contain dangerous substances. For information on the types in question please contact your nearest Infineon Technologies office.

Except as otherwise explicitly approved by Infineon Technologies in a written document signed by authorized representatives of Infineon Technologies, Infineon Technologies' products may not be used in any applications where a failure of the product or any consequences of the use thereof can reasonably be expected to result in personal injury.