

# USB On-The-Go (OTG) Basics

## Associated Part Family

CY7C67300/CY7C67200

## About this document

### Scope and purpose

This application note discusses several aspects of OTG functionality. The note introduces end-applications and different types of cables and connectors involved with OTG. It also describes the OTG protocol state changes when both Mini-A and Mini-B devices are connected. The host negotiation protocol (HNP) and session request protocol (SRP), which are part of the OTG protocol, are also explained.

## Table of contents

<b>Associated Part Family</b> .....	<b>1</b>
<b>About this document</b> .....	<b>1</b>
<b>Table of contents</b> .....	<b>1</b>
<b>1 Introduction</b> .....	<b>2</b>
<b>2 Cables</b> .....	<b>3</b>
<b>3 Host Negotiation Protocol (HNP)</b> .....	<b>5</b>
<b>4 Session Request Protocol (SRP)</b> .....	<b>7</b>
4.1 SRP-HNP “Shortcut” .....	11
<b>5 Summary</b> .....	<b>12</b>
<b>Revision History</b> .....	<b>12</b>

---

## Introduction

### 1 Introduction

The release of the On-The-Go (OTG) supplement to the USB 2.0 specification changed the USB world. For the first time, spec-compliant USB devices can talk to each other without requiring the services of a host computer. Cellphones and PDAs can exchange contact lists, phones can attach to printers and print faxes, and MP3 players can swap tunes.

To accomplish OTG functionality, a USB device must be able to function as a host, a role previously served exclusively by desktop or laptop personal computers. However, adding host capability to a USB device is only part of the requirements to operate as an OTG device. The OTG specification introduces new cables, connectors, and two new protocols - Session Request Protocol (SRP) and Host Negotiation Protocol (HNP).

Additionally, the OTG specification defines a new type of USB device with both host and peripheral capabilities called a “dualrole device”. This application note covers the electrical and protocol aspects of OTG, providing information that should make it easier to read and understand the formal OTG Specification.

Cables

## 2 Cables

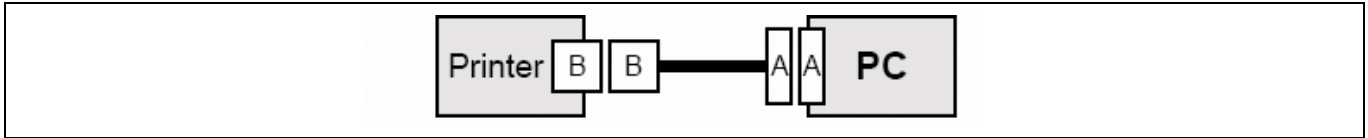

**Figure 1 Standard USB A-B Cable**

Two new cables and two adapters are defined in the OTG specification. **Figure 1** shows the traditional A and B connectors, and the standard A-to-B cable that connects USB peripherals to PC hosts. Following the **Figure 1** model, the OTG specification refers to hosts as “A” devices and peripherals as “B” devices.

In October 2000, the mini-B receptacle and plug were incorporated as standard USB components to allow portable equipment such as digital cameras and MP3 players to use a smaller connector than the relatively large “B” receptacle (see **Figure 2**).

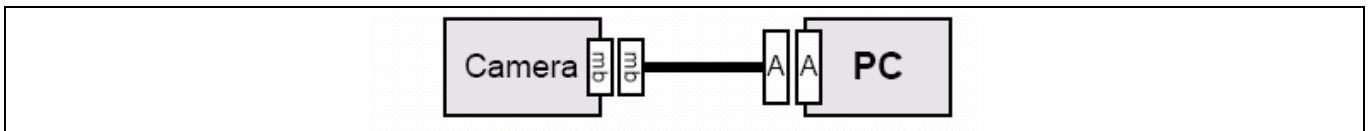

**Figure 2 Standard USB Mini-B Receptacle and Plug**

OTG introduces a new receptacle, the mini-AB, which accepts either the standard USB mini-B plug or a new OTG plug, the mini-A (see **Figure 3**). Fortunately, OTG was anticipated when the mini-B receptacle and plug were defined. Therefore, a mini-B plug mates with the new mini-AB receptacle. As **Figure 3** illustrates, a camera with the new OTG mini-AB receptacle is a direct substitute for the camera with the mini-B connector in **Figure 2**.

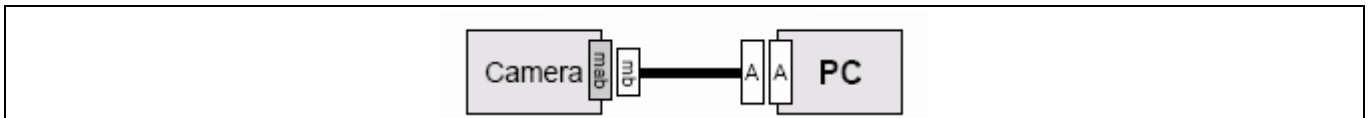

**Figure 3 New OTG Mini-AB Receptacle**

As its name implies, the mini-AB receptacle accepts either the standard mini-B plug, or a new OTG plug, the mini-A. Two new OTG cables are defined, the mini-A to B, and the mini-A to mini-B (see **Figure 4**).

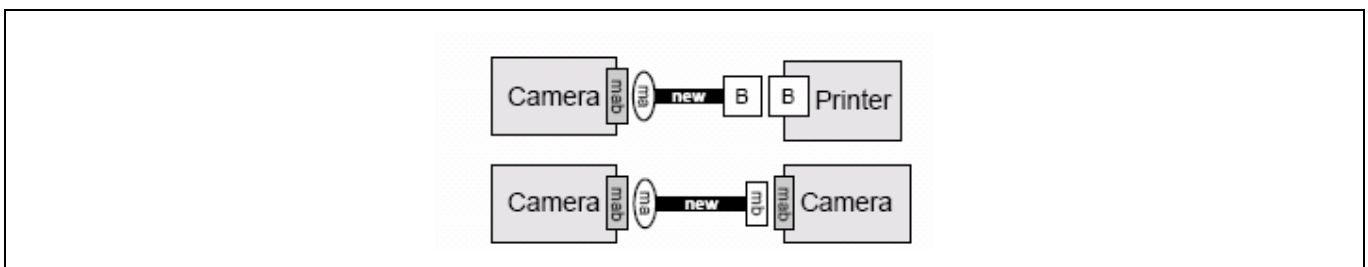

**Figure 4 Two New OTG Cables**

The top cable allows a new OTG device to talk as a host to a traditional USB peripheral. The bottom cable allows two OTG devices to talk to each other.

## Cables

In the **Figure 4** camera-to-camera connection, both dual-role cameras provide mini-AB receptacles. Therefore, each must function either as host or peripheral. This raises the obvious question of which is the host and which is the peripheral at connection. The OTG spec resolves this question in a very simple manner: the cable decides.

OTG receptacles and plugs contain a fifth pin, added to the standard four USB pins (VBUS, GND, D+, and D-). This is a fifth pin in the connector, not a fifth wire in the cable. The mini-A plug has the fifth pin tied to its ground pin, and the mini-B plug leaves the fifth pin unconnected. A dual-role device requires circuitry to read the state of this fifth pin (with, for example, the aid of a pull-up resistor) to determine which end of the cable is inserted.

The dual-role device receiving the mini-A plug is the default host. To understand why the word “default” is important, see the following figure.

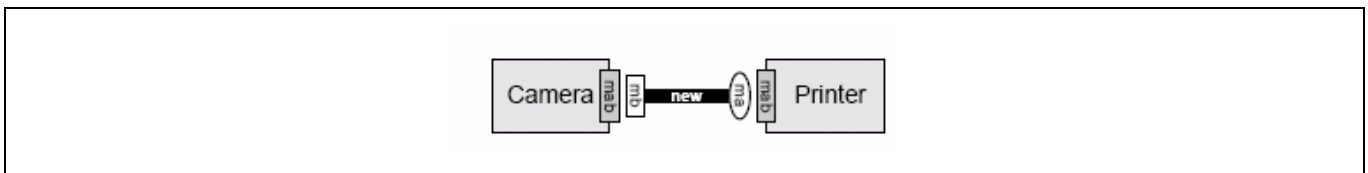

**Figure 5 Backwards Cable Connection**

In **Figure 5**, two dual-role devices are connected with a mini-A to mini-B cable. The camera contains a printer driver. However, the mini-A end of the cable is connected to the printer, making it the default host. This will be backwards - the camera must be the host in order to print.

The OTG architects put a lot of thought into the user experience. Realizing that the **Figure 5** connection is possible, they invented the HNP to allow two connected dual-role devices to exchange roles. Using HNP, the camera in **Figure 5** can assume the host role, even though the initial cable connection established the printer as the default host (A-Device). This saves (a) informing the user of a nonworkable connection, and (b) making the user remove the cable and plug it in “the other way”.

For an orderly startup, one of the devices must be the “initial” (default) host, a role established by the cable. After connection, the devices can use HNP to exchange roles.

*Note: Dual-role devices must operate at full speed (high-speed optional) as a peripheral. Dual-role devices must operate at full speed (low- and high-speed optional) as a host.*

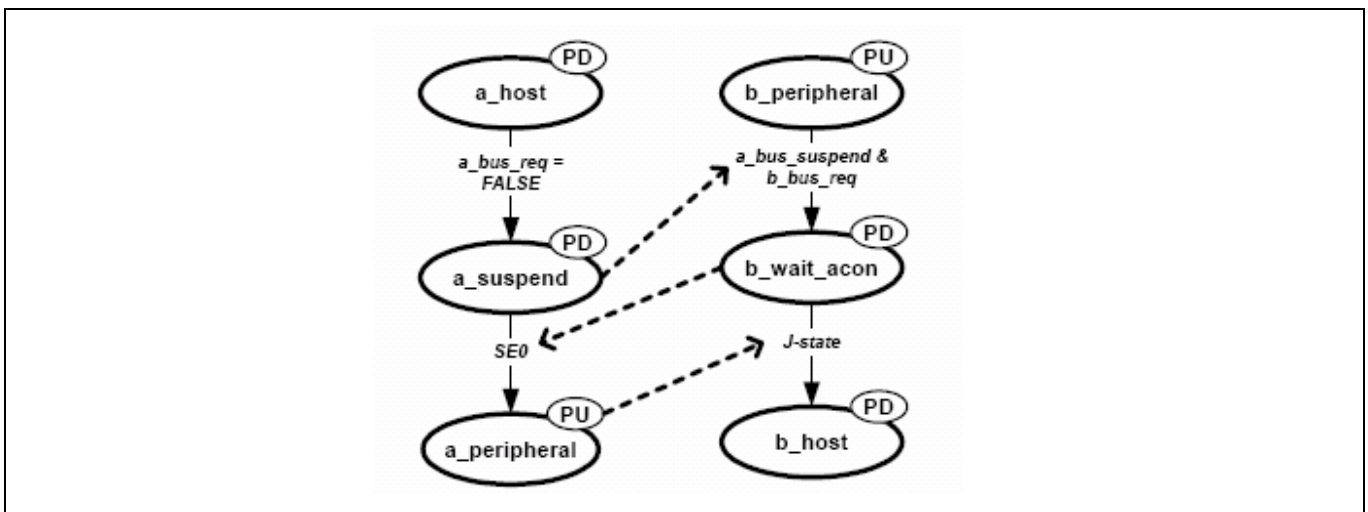

**Figure 6 HNP Simplified and Combined State Diagram**

---

**Host Negotiation Protocol (HNP)****3 Host Negotiation Protocol (HNP)**

The OTG specification provides an individual A-device and B-device state diagrams to illustrate how dual-role devices function. The state diagram shown in **Figure 6** is derived from these state diagrams. **Figure 6** combines the A- and B-device behaviors into one simplified diagram, which contains the states relevant to HNP. The A-device is on the left, and the B-device is on the right. As in the OTG spec, state names with the “a\_” prefix pertain to the A-device, and state names with the “b\_” prefix pertain to the B-device. The **Figure 6** state names and the italicized signal names are taken directly from the OTG specification. The added “PU” ovals indicate connection of the D+/D- pull-up resistor, and the “PD” ovals represent connection of the 15-kΩ pull-down resistors on D+ and D-.

Initial conditions are the A-device operating as host (a\_host state) and the B-device operating as a peripheral (b\_peripheral state). As a host, the A-device has its pull-down resistors turned on, and as a peripheral the B-device has its pull-up turned on. In this state, the A-device performs all the normal host duties, including bus reset, generating SOF packets, enumerating the B-device, and suspend-resume.

At some point, the application running on the A-device no longer needs to use the B-device. At this point, the A-device must give the B-device an opportunity to be the host. There are prerequisites to this benevolence:

- When the A-device enumerated the B-device, the B-device must return an OTG descriptor indicating that it is capable of supporting HNP. The B-device includes this descriptor in its response to the Get\_Descriptor(Configuration) request.
- The A-device enables the B-device for HNP by sending an OTG-specific Set\_Feature request (with feature selector, “b\_hnp\_enable”).

The application running on the A-device starts the HNP ball rolling by negating an internal signal called “a\_bus\_req”, indicating that it does not need to use the bus. To give the B-device a window of opportunity to become host, the A-device suspends the bus (a\_suspend state). The A-device suspends the bus according to standard USB protocol, that is, by stopping all bus traffic for at least 3 ms. Since the A-device still operates as the host, its pull-down resistors remain on.

The B-device, sensing that the bus is inactive, now tries to become the host. If the B-device is HNP-capable and the B-device has HNP-enabled, and the B-device detects that the A-device has suspended the bus, and the application running on the B-device wants to request the bus (b\_bus\_req signal), then the B-device transitions to the b\_wait\_acon state. This means “the B-device waits for the A-device to connect”. In this state the B-device “disconnects” by turning its pull-up resistor off and turning its pull-down resistors on. Because neither side is driving the bus, the pull-downs cause D+ and D- to go LOW, a condition known as a single-ended - zero (SE0).

After “disconnecting,” the B-device waits in the b\_wait\_acon state for the A-device to “connect” as a peripheral. The A-device, which is in the a\_suspend state, detects the SE0, and transitions to a peripheral state, where it “connects” as a peripheral in the normal USB way, by powering its D+ pull-up resistor. This connection creates a J-state on the bus, which the B-device detects as an A-device peripheral connect event. This causes the B-device to transition to the b\_host state, and the role reversal is complete.

Going the opposite way, from A-peripheral/B-host back to A-host/B-peripheral, is very similar. The B-device suspends and the A-device disconnects.

The OTG specification imposes timing constraints on the state transitions. For example, the A-device must make its transition from a\_suspend to a\_peripheral within 3 ms of detecting an SE0 on the bus. After it enters the a\_peripheral state, it must maintain its connected state for at least 3 ms to give the B-device time to respond and generate a bus reset. The B-device has 1 ms to detect and respond to the A-device connect, so the 3-ms holding time insures 2 ms of margin.

---

### Host Negotiation Protocol (HNP)

The simplified **Figure 6** state diagram omits many details for clarity. It shows the normal progression of events for a successful HNP role switch. The OTG specification also covers the “else” conditions such as a mid-HNP cable detach.

The OTG state diagrams use “timer variables” to resolve some signaling issues. For example, in the `b_wait_acon` state, the B-device waits for a J-state on the bus, signifying that the A-device has connected as a peripheral. When the B-device is in its `b_wait_acon` state, the A-device is in its `a_suspend` state. Therefore, neither side drives the bus, resulting in a SE0 bus state. However, a SE0 can also represent a USB bus reset, if it is held for 10 ms. Therefore the B-device must revert to the `b_peripheral` state if, while in the `b_wait_acon` state, it does not detect a J-state within 3.125 ms.

## Session Request Protocol (SRP)

### 4 Session Request Protocol (SRP)

The OTG specification contributes a new mechanism that allows an A-device to turn off VBUS as a power saving measure. From this state, a B-device can wake up the A-device by asking it to turn on VBUS and start a new session. This mechanism is called session request protocol (SRP).

The relationship between SRP and HNP can be summarized as follows:

- Dual-role devices are required to be able to initiate and respond to SRP.
- The A-device always provides VBUS. Even if two dual-role devices use HNP to make the B-device a host and the A-device a peripheral, the A-device still supplies VBUS.
- Non dual-role devices, which are inherently incapable of HNP, may still initiate SRP. For example, a mouse with an internal battery can request a session from a dual-role device.

A “session” is defined as the period of time during which VBUS is on, or more particularly, VBUS is above a device’s “session valid” threshold voltage.

B-devices use two methods to request a session: data line pulsing followed by VBUS pulsing. A-devices are required to respond to one of the two signaling methods, but a B-device must use both methods to insure that any A-device recognizes it.

B-devices perform data line pulsing by powering their D+/D– pull-up resistor for 5 to 10 ms. Dual-role devices must use the D+ pull-up. B-devices perform VBUS pulsing by driving VBUS. Driving power on to a wire connected to an “off” power source (in the A-device) obviously requires some care. The following discussion illustrates the important factors by working through a simplified example, pointing out the important OTG spec issues.

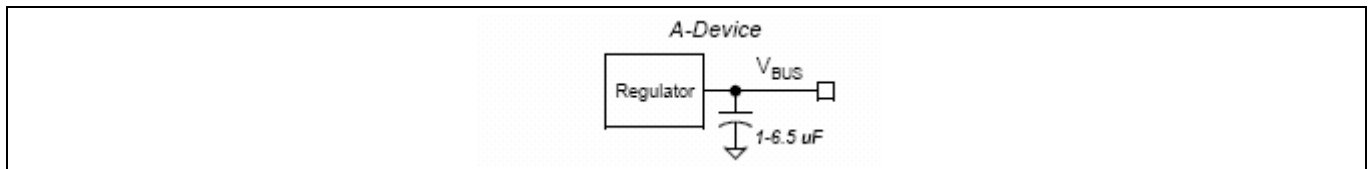

**Figure 7 An OTG A-Device Powering VBUS**

An OTG dual-role device must have a power decoupling capacitor that is in the range of 1.0 to 6.5  $\mu\text{F}$  (see [Figure 7](#)). This is a departure from a classic host, which has a minimum VBUS capacitance of about 95  $\mu\text{F}$  (this value takes capacitor tolerance into effect). This large capacitance difference allows the SRP VBUS pulsing method to be recognized by a dual-role device while causing no damage if the B-device plugs into a standard host.

An A-device must be able supply at least 8 mA of VBUS current at 4.4 V, the minimum voltage necessary to guarantee proper B-device operation. A voltage comparator with a 4.4 V (minimum) threshold in the A-device provides a signal called a\_vbus\_valid. The spec requires a\_vbus\_valid to be true within 100 ms after the A-device turns on VBUS.

Note that if a\_vbus\_valid does not go TRUE within 100 ms, this implies that the B-device is drawing more current than the A-device can supply. Therefore, the A-device turns off VBUS and terminates the session.

An unpowered A-device must present an input impedance less than 100 k $\Omega$ . If the device is designed to respond to the VBUS pulsing method, the input impedance must be at least 40 k $\Omega$  ([Figure 8](#)).

## Session Request Protocol (SRP)

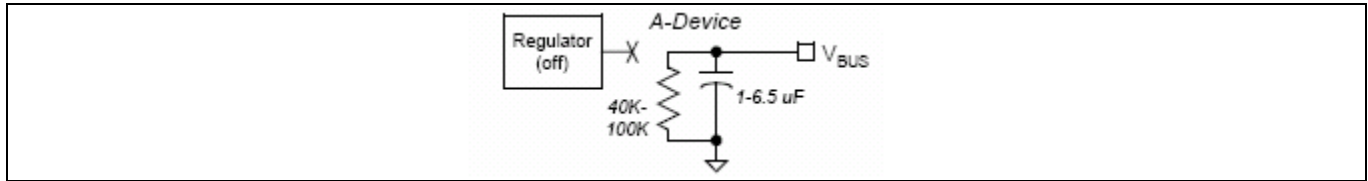

**Figure 8 Load Presented by an Unpowered A-Device**

Before starting SRP, the B-device must first ensure that VBUS is low enough that a SRP-capable A-device is below its session valid threshold (0.8V min.). One way to do this is simply to wait for the pull-down resistors to discharge the bypass capacitors. If two dual-role devices are connected, then the weakest pull-down is the parallel combination of two 100-K resistors, and the maximum capacitance is 2\*6.5 μF. Using these worst-case values leads to the longest discharge time being approximately 1.1 seconds.

The B-device may speed this discharge by connecting a resistor from VBUS to ground. Because the maximum current the B-device may draw is 8 mA, the minimum resistance to ground is 5.25 V / 8 mA = 656 Ω. The R-C time constant for the discharge is then (656 Ω)(13 μF) = 8.5 ms. The VBUS capacitance can discharge from 5.25 V to 0.8 V in 1.88 time constants, or 16 ms.

*Note: The 5.25-V starting voltage is conservative because the B-device may not initiate SRP until VBUS has dropped below its session threshold of 4.4 V (max).*

As an alternative to timing the discharge, the B-device may use a 0.8-V “session end” comparator to directly measure VBUS (**Figure 9**).

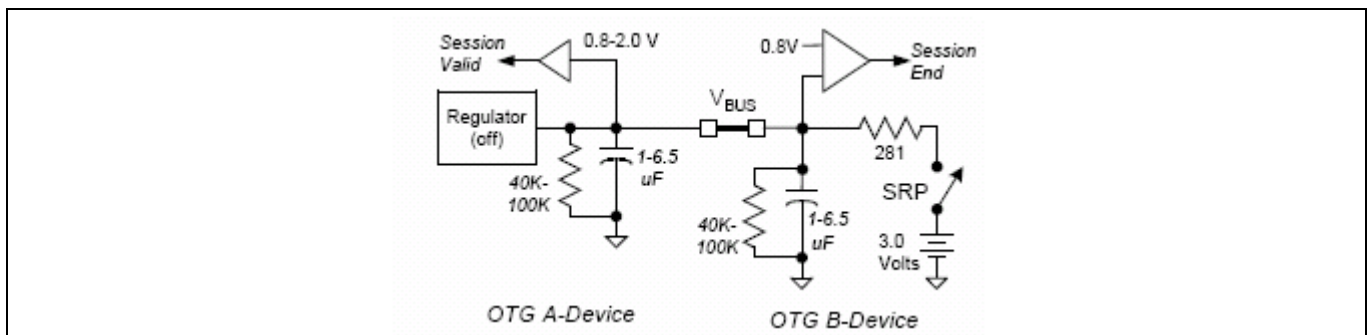

**Figure 9 B-Device Pulses VBUS to Wake Up A-Device**

Having determined that VBUS is under 0.8 V, the B-device may attempt to wake up the A-device by pulsing VBUS. The example circuit in **Figure 9** shows a 281 Ω current-limiting resistor, whose value is calculated to guarantee that the unconfigured B-device never draws more than the OTG-specified 8 mA, as follows. The worst-case current draw occurs when the A-device turns on VBUS while the B-device is still signaling SRP, and the B-device VCC is the minimum 3.0 V, causing the largest voltage difference between the devices. The minimum series resistance required to limit the current flowing into the B-device is derived as follows:

$$(5.25 \text{ V} - 3.0 \text{ V}) / 8 \text{ mA} = 281 \Omega$$

Two factors determine how long the B-device should pulse VBUS. The pulse width must be:

1. Long enough to guarantee that the maximum capacitance of two dual-role devices (13 μF) is charged to at least 2.1 V.
2. Short enough to guarantee that the capacitance of a legacy host (95 μF) is not driven above 2.0 V.



## Session Request Protocol (SRP)

The designer of the B-device knows the current limit of its VBUS charging circuit. Using the example circuit of **Figure 9** with the maximum capacitance values, and ignoring the pull-down resistors, one R-C time constant is approximately:  $RC = 281 \cdot 13 \mu\text{F} = 3.6 \text{ ms}$

A discharged R-C network reaches 0.950 of its driving voltage after three time constants. Using the minimum VCC of 3.0 V, driving VBUS for three time constants (10 ms) raises the voltage by  $3 \text{ V} \cdot .95$  or 2.85 V, which is above the required 2.1 V spec value (so the first condition is met).

*Note: Ten milliseconds is a conservative charging time. It takes 1.2 time constants to charge from 0.0 V to 2.1 V with a 3-V supply. Ignoring component tolerances, and using the 3.6-ms time constant, charging from 0 V to 2.1 V takes  $3.6 \cdot 1.2 = 4.4 \text{ ms}$ . Nevertheless, we use the more conservative 10 ms value for the example calculation.*

The next step is to check the effect of this pulse when the B-device is plugged into a standard USB host.

Assume that the B-device has a session-end comparator, as in **Figure 9**. In the OTG spec, the output of this comparator is the signal `b_session_end`. The B-device may either wait 1.1 seconds, or pull down VBUS through a resistor (for example a 656-Ω resistor for 16 ms) to try to pull VBUS below 0.8 V. If the attempt fails (`b_session_end` is not TRUE), the B-device can deduce that it is either:

1. Not connected to a dual-role device (whose VBUS discharges below 0.8 V due to its much smaller capacitance)
2. It is plugged into an A-device that is driving VBUS.

The first case happens if the standard host had very recently powered down, leaving a residual voltage on its VBUS capacitor(s). In either case, the B-device should go to the `b_peripheral` state, where it cannot initiate SRP until its `session_valid` variable goes FALSE.

Pulsing a VBUS capacitance of 96 uF through a 281-Ω resistor for the computed 10 ms raises the capacitor voltage by:

$$V_c = (3.6 \text{ V} - 0.8 \text{ V}) (1 - e^{-t/RC}) = 0.87 \text{ V}$$

Since the assumption is a worst-case initial VBUS voltage of 0.8 V, the resulting voltage across the VBUS capacitance is

$$0.8 \text{ V} + 0.87 \text{ V} = 1.67 \text{ V}, \text{ safely below the } 2.0 \text{ V limit.}$$

Note that if the B-device tested for end-of-session by connecting a 656-Ω resistor to ground for 16 ms (as in this example), the voltage on the capacitor initially decreased by 1.82 V before the B-device applied the VBUS pulse. Therefore, the pulse does not raise VBUS above its starting value.

As long as the design ensures that more charge is removed than added to the VBUS decoupling capacitance by a VBUS pulse, a standard USB host is unaffected and undamaged by the pulse.

This discharge-before-charge sequence allows a cost sensitive B-device to replace the session-end comparator with a simple gate, as shown in **Figure 10**. In this case the B-device must time the discharge of the VBUS capacitor as previously describe because it cannot precisely measure 0.8 V. Before pulsing VBUS, the B-device must insure that the `b_session_valid` variable is FALSE, whatever the threshold voltage of the gate is. Since the detection method involves a discharge mechanism for the VBUS capacitance prior to pulsing VBUS, the designer can insure that no net voltage increase occurs on VBUS and, therefore, that the VBUS pulse does not inadvertently trip the B-device's session-valid threshold.

Session Request Protocol (SRP)

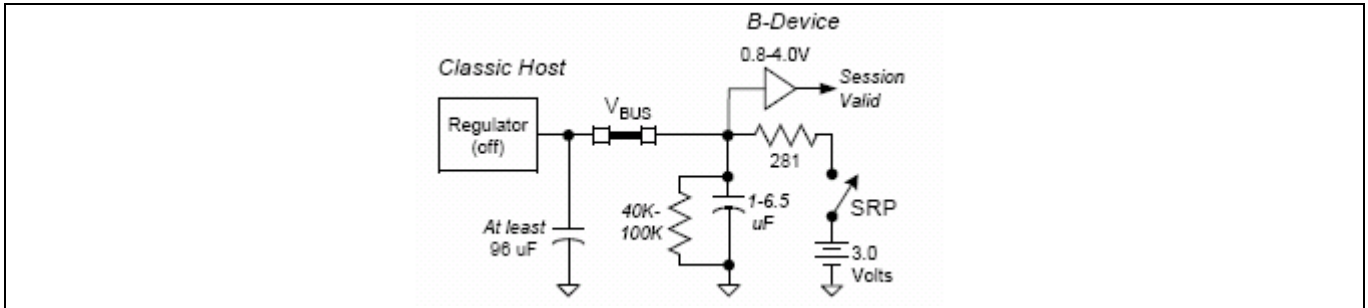

Figure 10 A Cost-Sensitive B-Device

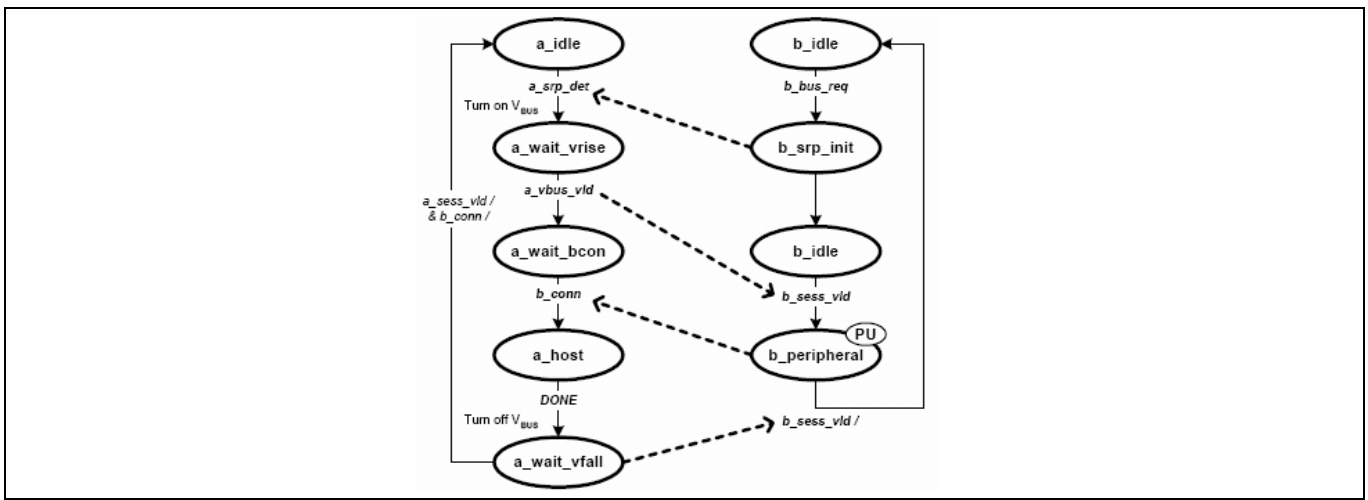

Figure 11 SRP Simplified and Combined State Diagram

To help understand the A and B-device interactions while performing SRP, the state diagram in [Figure 11](#) simplifies and combines the OTG specification A-device and B-device state diagrams.

Before starting a new session, the B-device must insure that two initial conditions are valid:

- No session is in progress ( $V_{BUS} < 0.8\text{ V}$ )
- While in the `b_idle` state (which disconnects the B-Device’s pull-up resistor, creating an SE0 on the bus), the bus must have been in the SE0 state for at least 2 ms.

After these conditions are met, the application running on the B-device can indicate that it wants to use the bus (to signal a wakeup) by asserting the `b_bus_req` signal, causing the B-device to transition to the `b_srp_init` metastate. (A “metastate” is a state containing other states or behaviors; in this example, the `b_srp_init` state contains the data-pulsing and VBUS pulsing methods described above.)

The A-device must be in its `a_idle` state to detect the B-device attempting to initiate SRP, and when it sees the `a_srp_det` variable go true, it turns on VBUS and transitions to the `a_wait_vrise` state, where it waits for VBUS to reach a valid level (4.4 V minimum). The B-device, having finished its SRP signaling, transitions back to its `b_idle` state, where it waits for the A-device to indicate a valid session.

Meanwhile, back at the A-device, when VBUS reaches its session threshold voltage (4.4 V), it transitions to its `a_wait_bcon` state, where it waits for the B-device to “connect” by turning on its pull-up resistor. The B-device, sensing that VBUS has exceeded its session valid threshold voltage (0.8 V–4.0 V), transitions to the `b_peripheral` state. Here it turns on its data pull-up resistor. The A-device senses this as the `b_conn` signal, which, after adequate debounce time of the data line, causes a transition to `a_host`. The A-device operates in its `a_host` metastate, exhibiting all host behavior, and the B-device operates in its `b_peripheral` metastate, exhibiting all peripheral behavior.

## Session Request Protocol (SRP)

At some point, the A-device is done with the session. One of the many possible definitions of “done” is that the A-device batteries are dangerously low. In this particular case, since the A-device cannot continue to power VBUS and allow the B-device to become host, the A-device turns off VBUS and transitions to `a_wait_fall`. The B-device, also sensing the drop in VBUS as it drops below the B-device’s session-valid threshold (0.8 V–4.0 V), transitions back to its `b_idle` state.

The A-device waits in its `a_wait_vfall` state until two requirements are met:

1. VBUS has dropped below the A-device’s session-valid voltage
2. The B-device has indicated its session is over by disconnecting its data pull-up resistor (the variable `b_conn` is FALSE).

The second requirement avoids a subtle race condition. If the A-device made its transition to `a_idle` before the B-device turned off its pull-up resistor (indicating that the B-device knows its session is over), the A-device finds a data line high and thinks the B-device (again) signals SRP, and immediately transitions to the `a_wait_vrise` state.

### 4.1 SRP-HNP “Shortcut”

An interaction between SRP and HNP is worth noting. To save time, the A-device can just come on and send a SetFeature (`b_hnp_enable`) request. If the B-device does not STALL, then the B-device is HNP-capable and the A-device can immediately suspend and start HNP. This is especially useful if the B-device did SRP because it gains control quickly. If the B-device did SRP but STALLS the SetFeature (`b_hnp_enable`) request, it is a peripheral-only device and the A-device goes ahead and enumerates it.

## Summary

### 5 Summary

Although the example design presented in this note uses simplified diagrams and values, the example calculations and state diagrams should aid the understanding of what constitutes a spec-compliant OTG device. The background information presented in this note helps readers navigate the parameters and state diagrams in the OTG specification.

### Revision History

Document version	Date of release	Description of changes
**	2020-11-26	Created spec number and updated template for an old application note that was there on the website.
*A	2013-03-12	No technical updates. Completing Sunset Review.
*B	2014-04-03	Updated in new template.
*C	2016-11-25	Updated to new template. Updated Copyright and Disclaimer.
*D	2017-07-04	Updated logo and copyright.
*E	2021-03-19	Updated to Infineon template.

#### Trademarks

All referenced product or service names and trademarks are the property of their respective owners.

**Edition 2021-03-19**

**Published by**

**Infineon Technologies AG**

**81726 Munich, Germany**

**© 2021 Infineon Technologies AG.**

**All Rights Reserved.**

**Do you have a question about this document?**

**Go to [www.cypress.com/support](http://www.cypress.com/support)**

**Document reference**

**001-65231 Rev.\*E**

#### IMPORTANT NOTICE

The information contained in this application note is given as a hint for the implementation of the product only and shall in no event be regarded as a description or warranty of a certain functionality, condition or quality of the product. Before implementation of the product, the recipient of this application note must verify any function and other technical information given herein in the real application. Infineon Technologies hereby disclaims any and all warranties and liabilities of any kind (including without limitation warranties of non-infringement of intellectual property rights of any third party) with respect to any and all information given in this application note.

The data contained in this document is exclusively intended for technically trained staff. It is the responsibility of customer's technical departments to evaluate the suitability of the product for the intended application and the completeness of the product information given in this document with respect to such application.

For further information on the product, technology, delivery terms and conditions and prices please contact your nearest Infineon Technologies office ([www.infineon.com](http://www.infineon.com)).

#### WARNINGS

Due to technical requirements products may contain dangerous substances. For information on the types in question please contact your nearest Infineon Technologies office.

Except as otherwise explicitly approved by Infineon Technologies in a written document signed by authorized representatives of Infineon Technologies, Infineon Technologies' products may not be used in any applications where a failure of the product or any consequences of the use thereof can reasonably be expected to result in personal injury.