

BGT60ATR24C ES shield characterization

XENSIV™ 60 GHz radar system platform

Board version V2.0

About this document

Scope and purpose

This application note describes the performance characterization measurements of the BGT60ATR24C ES shield (SHIELD_60ATR24ES_01), part of Infineon's XENSIV™ 60 GHz radar system platform. The shield provides the supporting circuitry to the on-board BGT60ATR24C monolithic microwave integrated circuit (MMIC) Infineon's 60 GHz radar chipset with external antennas. The shield offers a digital interface for configuration and transfer of the acquired radar data to a microcontroller board, e.g., Radar Baseboard MCU7.

The MMIC-related parameters mentioned in the document are based on engineering samples (ES).

Intended audience

The intended audience for this document are design engineers, technicians, and developers of electronic systems, working with Infineon's XENSIV™ 60 GHz radar sensors, especially in automotive scenarios called in-cabin sensing (ICMS). Among the many applications it can be used for are – rear occupancy alert (ROA) and – left behind child (LBC) systems.

Related documents

Additional information can be found in the documentation provided with the [Radar Development Kit](#) tool in the [Infineon Developer Center \(IDC\)](#), or from www.infineon.com/60GHz.

Table of contents

About this document..... 1

Table of contents..... 2

1 Introduction 3

1.1 Device overview and orientation3

1.2 Virtual antenna array3

2 Measurement setup and characterization algorithm 5

2.1 Anechoic antenna chamber5

2.2 Measurement parameters and settings6

2.3 Characterization algorithm.....6

3 Amplitude characterization..... 8

3.1 Amplitude characteristics over boards8

3.1.1 58 to 61 GHz.....8

3.1.2 58.5 to 61.5 GHz.....11

3.1.3 59 to 62 GHz.....13

3.1.4 58 to 62 GHz.....16

3.2 Amplitude characteristics over frequency18

3.3 Half-power beam width21

4 Angle estimation22

4.1 Direction of arrival estimation22

4.2 Reconstructed angles.....22

4.2.1 58 to 61 GHz.....23

4.2.2 58.5 to 61.5 GHz.....24

4.2.3 59 to 62 GHz.....25

4.2.4 58 to 62 GHz.....26

4.3 Statistical analysis.....27

4.3.1 Angle span: ±30 degrees horizontal/vertical.....27

4.3.2 Angle span: ±40 degrees horizontal/vertical.....27

4.3.3 Angle span: ±50 degrees horizontal/vertical.....28

5 Summary and remarks.....29

References.....30

Revision history.....31

Disclaimer.....32

1 Introduction

1.1 Device overview and orientation

The BGT60ATR24C ES shield is the demo platform for Infineon’s 60 GHz radar sensor. This application note focuses on the performance characterization measurements of the radar sensor board. Detailed documentation on the radar sensor board can be found in application note AN620 [1].

Figure 1 shows the orientation of the external transmit and receive antennas on the BGT60ATR24C ES shield. The distance between the adjacent Rx antennas is half-wavelength, which corresponds to 0.25 cm. For Tx antennas, the offset is again half-wavelength for both directions.

The RF shield has a minimized form factor of 16 x 26 mm with external antennas, and the chipset size is 6 x 6 mm.

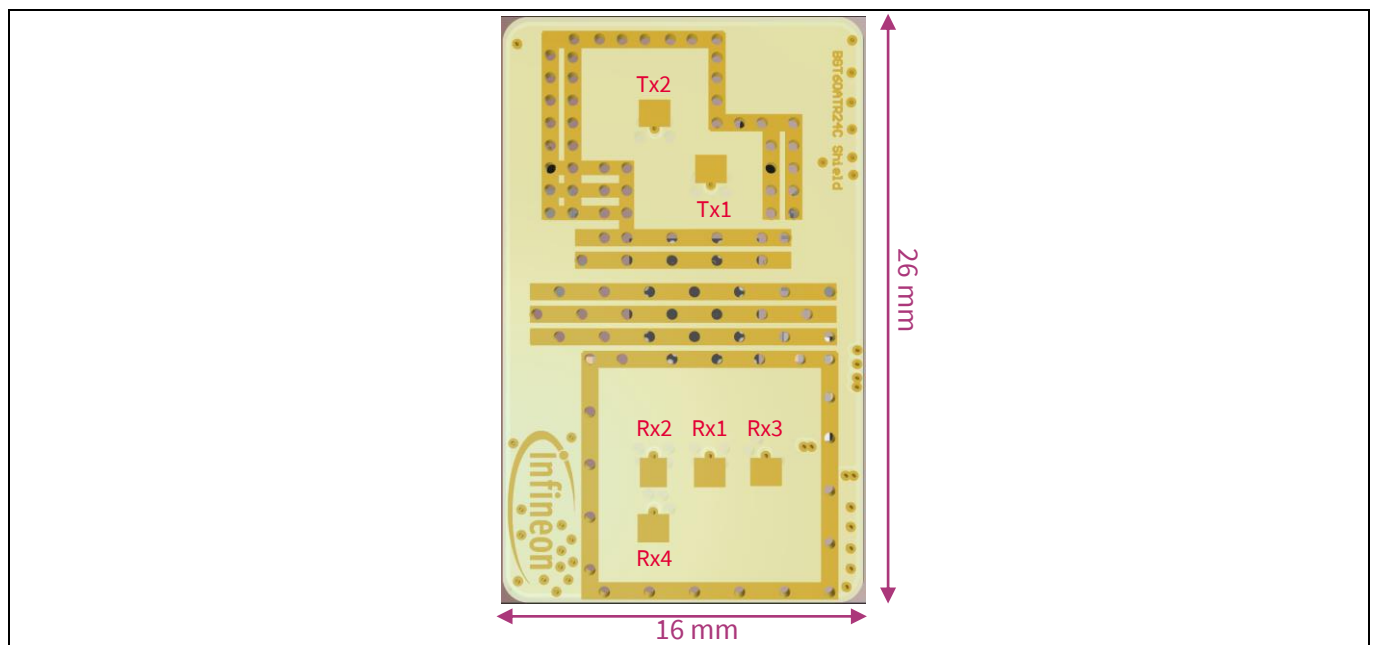

Figure 1 Antenna orientation and size of the BGT60ATR24C ES shield

1.2 Virtual antenna array

With two Tx and four Rx channels, the BGT60ATR24C ES shield can be used in multiple-input and multiple-output (MIMO) mode. With these antennas, a virtual antenna array that consists of eight elements can be achieved, as illustrated in Figure 2.

BGT60ATR24C ES shield characterization

XENSIV™ 60 GHz radar system platform

1 Introduction

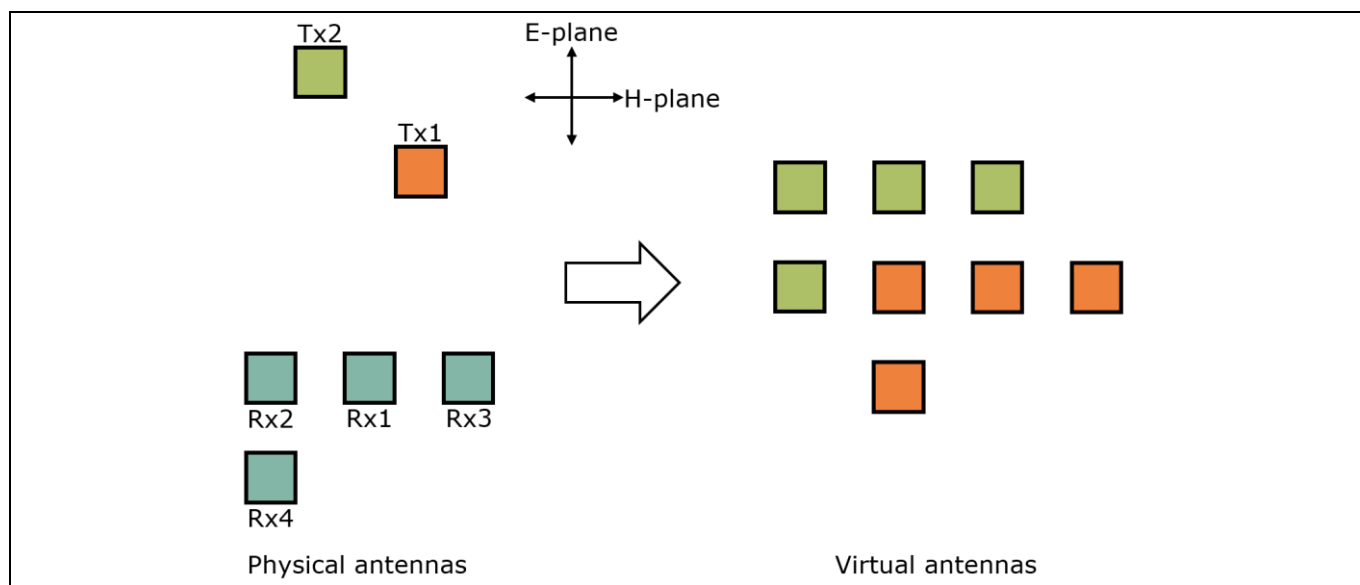

Figure 2 Orientation of the physical antennas and corresponding virtual antenna array

2 Measurement setup and characterization algorithm

2.1 Anechoic antenna chamber

The characterization measurements are taken in the anechoic antenna chamber shown in Figure 3. A corner reflector is used in front of the radar as a stable target.

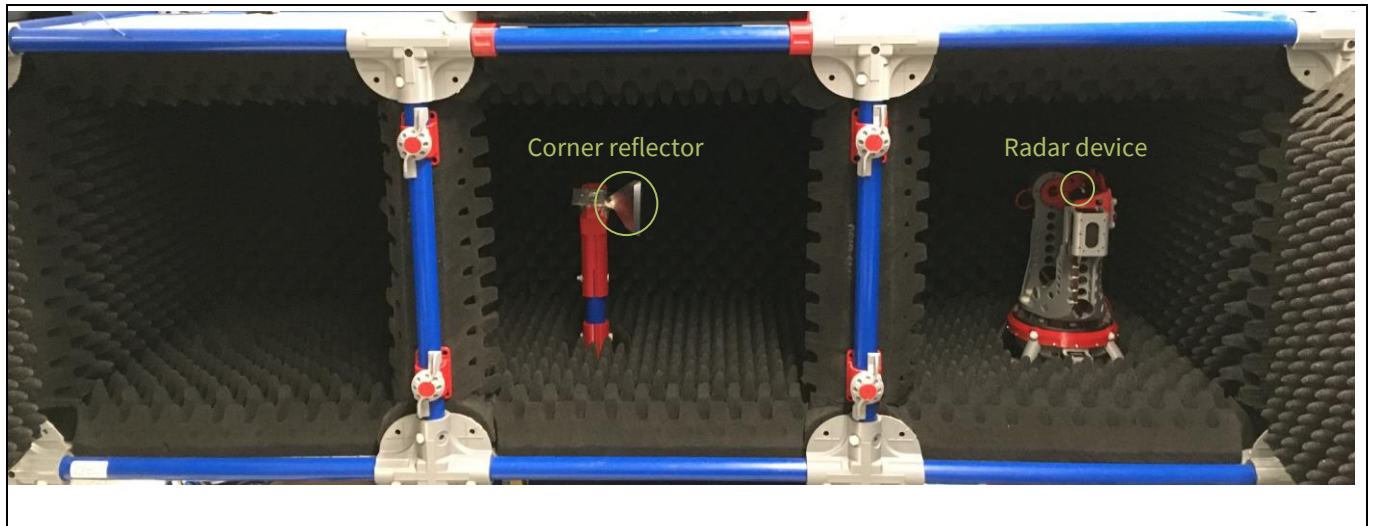

Figure 3 Anechoic antenna chamber used for the measurements

The antenna positioner (gimbal) in Figure 4 is used for horizontal and vertical axis rotations of antennas. The measurements are taken for each vertical position by scanning all horizontal angles at that angle.

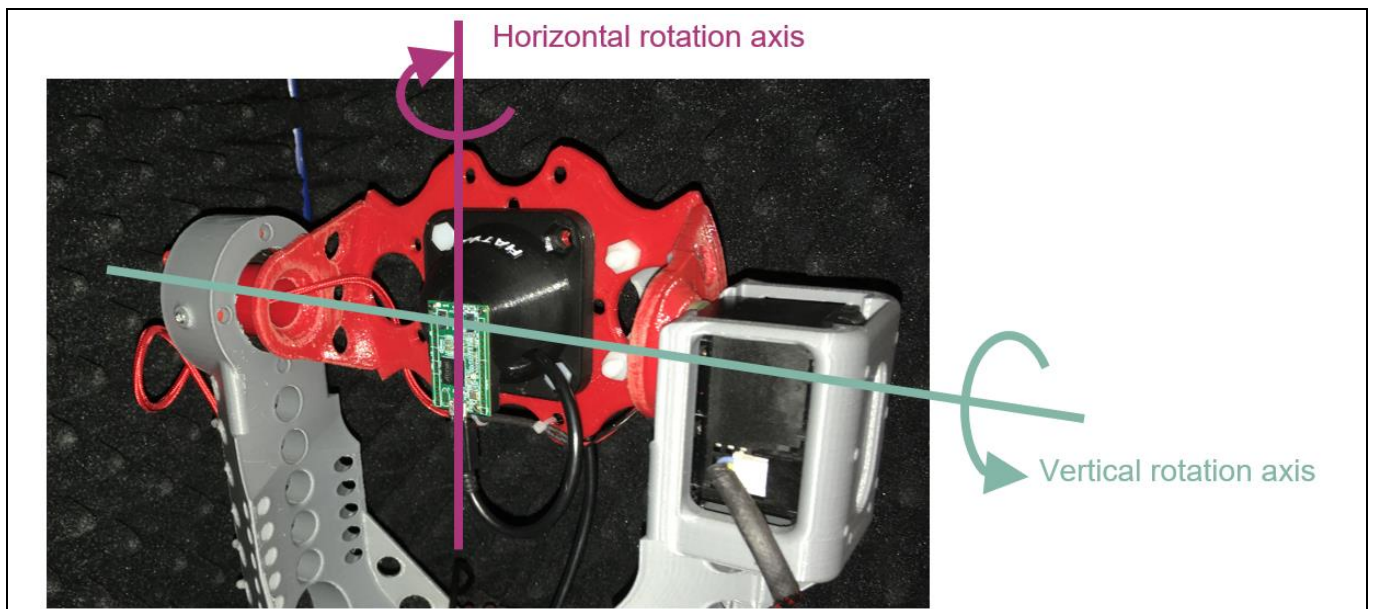

Figure 4 Antenna positioner (gimbal) for horizontal and vertical rotation of antennas

BGT60ATR24C ES shield characterization

XENSIV™ 60 GHz radar system platform

2 Measurement setup and characterization algorithm

2.2 Measurement parameters and settings

Table 1 Measurement parameters and settings

| Parameter | Value |
|-------------------------------|--|
| Horizontal measurement angles | -50 degrees to +50 degrees with 5-degree steps |
| Vertical measurement angles | -50 degrees to +50 degrees with 5-degree steps |
| Total measured angles | 441 |
| Distance to corner reflector | 1.4 m |
| Tx output power setting | 31 |
| Measured frequency bands | 58 to 62 GHz 58 to 61 GHz 58.5 to 61.5 GHz 59 to 62 GHz |
| Number of Rx antennas | 4 |
| Number of Tx antennas | 2 |
| Number of samples per chirp | 128 |
| Number of chirps per frame | 32 |
| Number of frames | 10 |
| HP_GAIN | 1 |
| HP_CUTOFF | 3 |
| VGA_GAIN | 3 |

2.3 Characterization algorithm

In order to reconstruct the amplitude and angle information from the measurements, the characterization algorithm in Figure 5 is used. The algorithm is repeated for each measured angle to obtain amplitude and angle characteristics for the measurement span.

The amplitudes are illustrated with heatmaps for each virtual antenna element, as in the upper-right plots of Figure 5. For angle estimation, all virtual antennas are used for the digital beamforming algorithm. The azimuth and elevation angles are reconstructed separately and illustrated with 3D and 2D plots, as in the lower-right plots of Figure 5.

BGT60ATR24C ES shield characterization

XENSIV™ 60 GHz radar system platform

2 Measurement setup and characterization algorithm

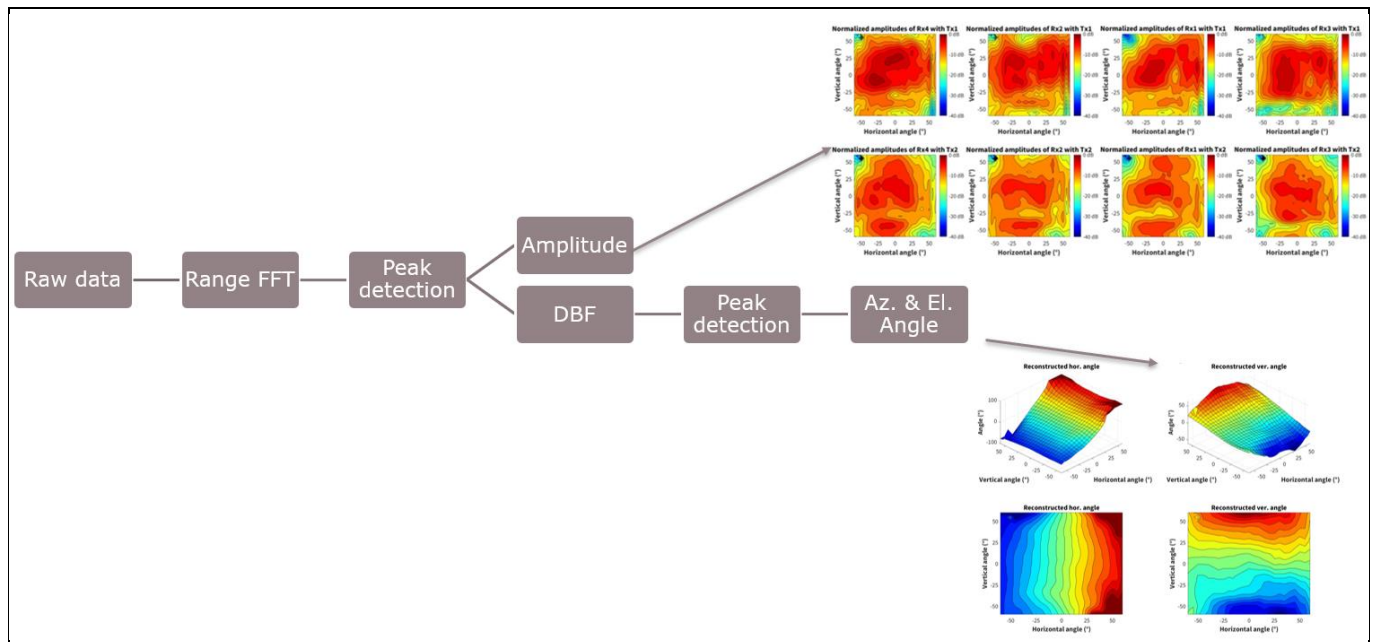

Figure 5 Characterization algorithm for amplitude and angle reconstruction

3 Amplitude characterization

This section of the document presents a detailed overview of the amplitudes over measurement angles for different frequency bands, boards, and antennas.

3.1 Amplitude characteristics over boards

In this section, characteristics are compared for different boards for each frequency band. For each amplitude characteristic, the corresponding signal-to-antenna chamber noise ratio (SACNR) is also plotted.

3.1.1 58 to 61 GHz

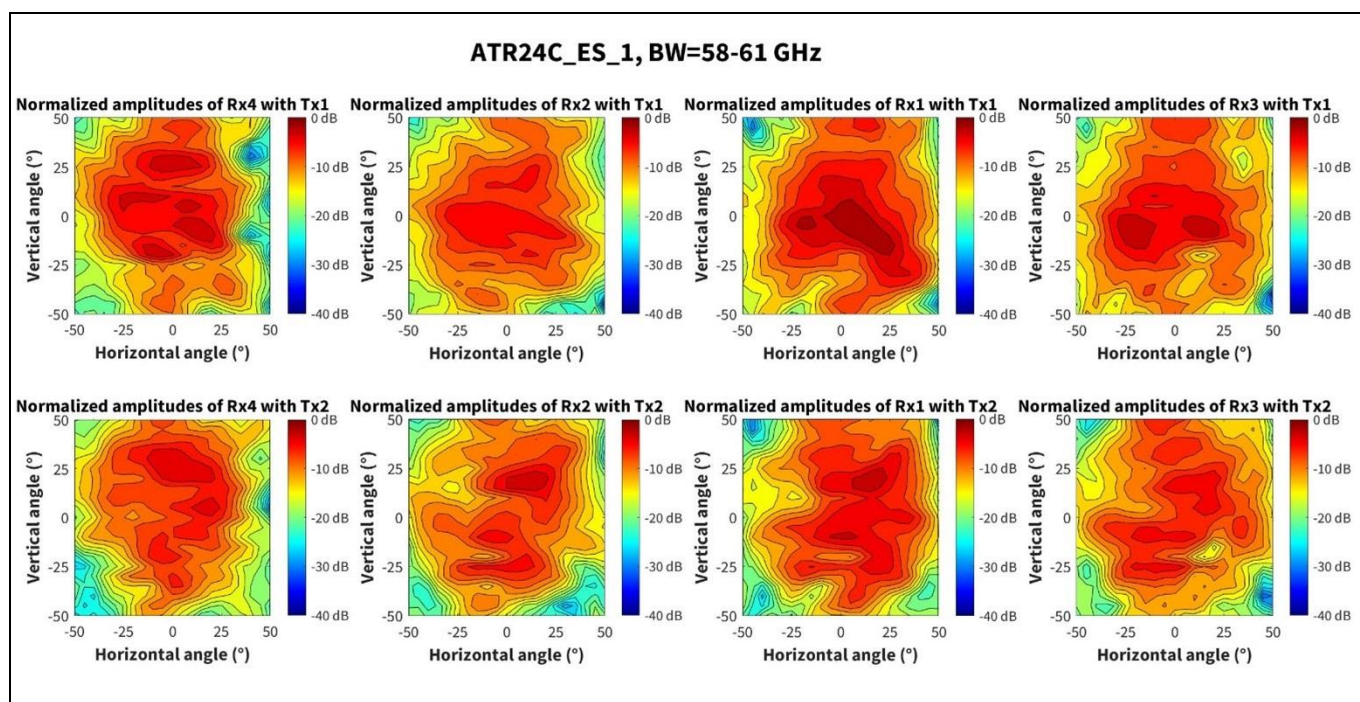

Figure 6 Amplitude characteristics of all virtual antennas for 58 to 61 GHz band

BGT60ATR24C ES shield characterization

XENSIV™ 60 GHz radar system platform

3 Amplitude characterization

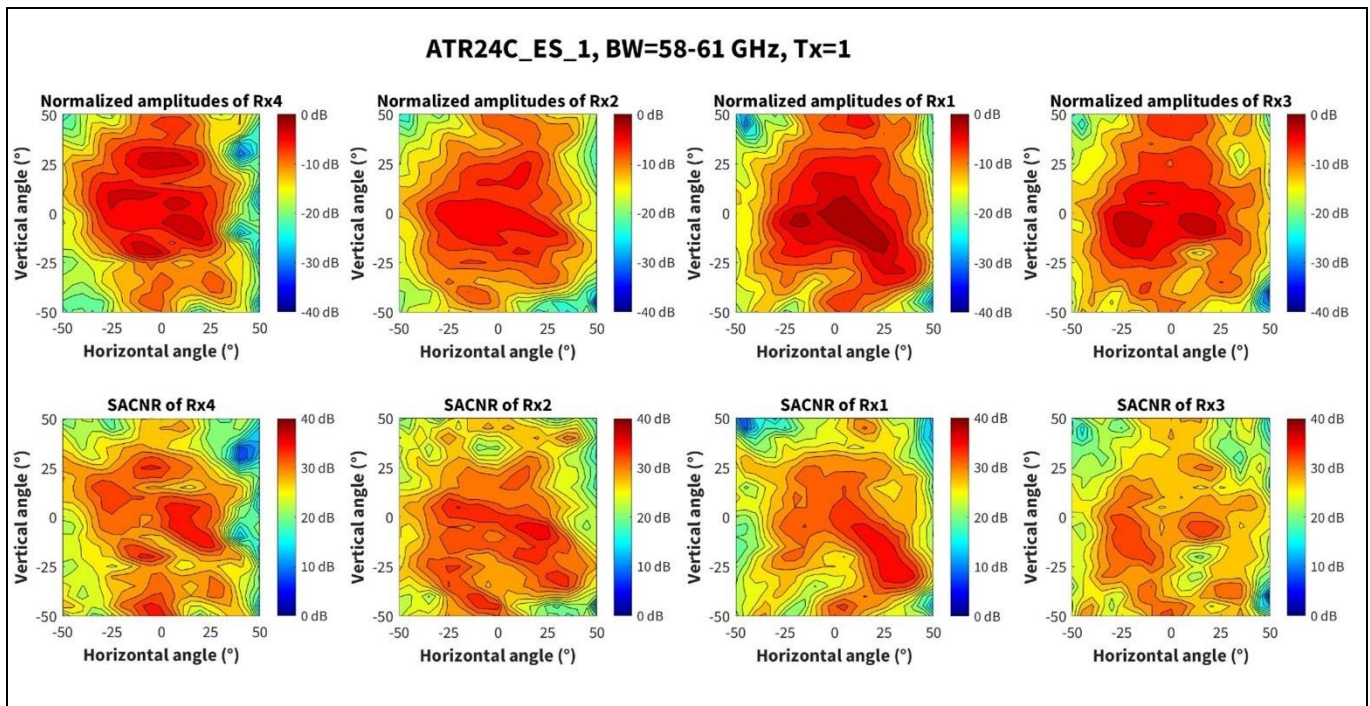

Figure 7 Amplitude and SACNR characteristics with Tx1 channel for 58 to 61 GHz band

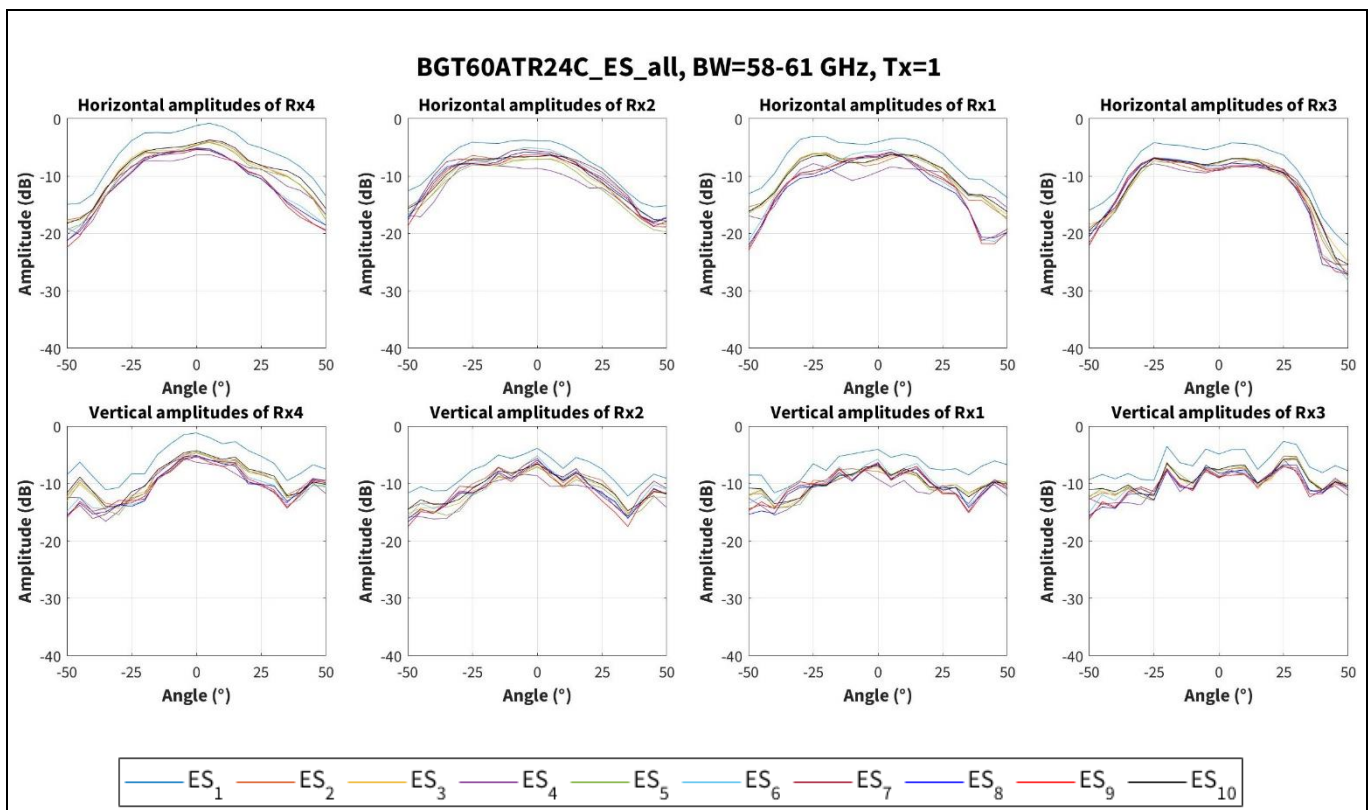

Figure 8 Amplitude characteristics on horizontal and vertical cross-sections with Tx1 channel for 58 to 61 GHz band for 10 boards

BGT60ATR24C ES shield characterization

XENSIV™ 60 GHz radar system platform

3 Amplitude characterization

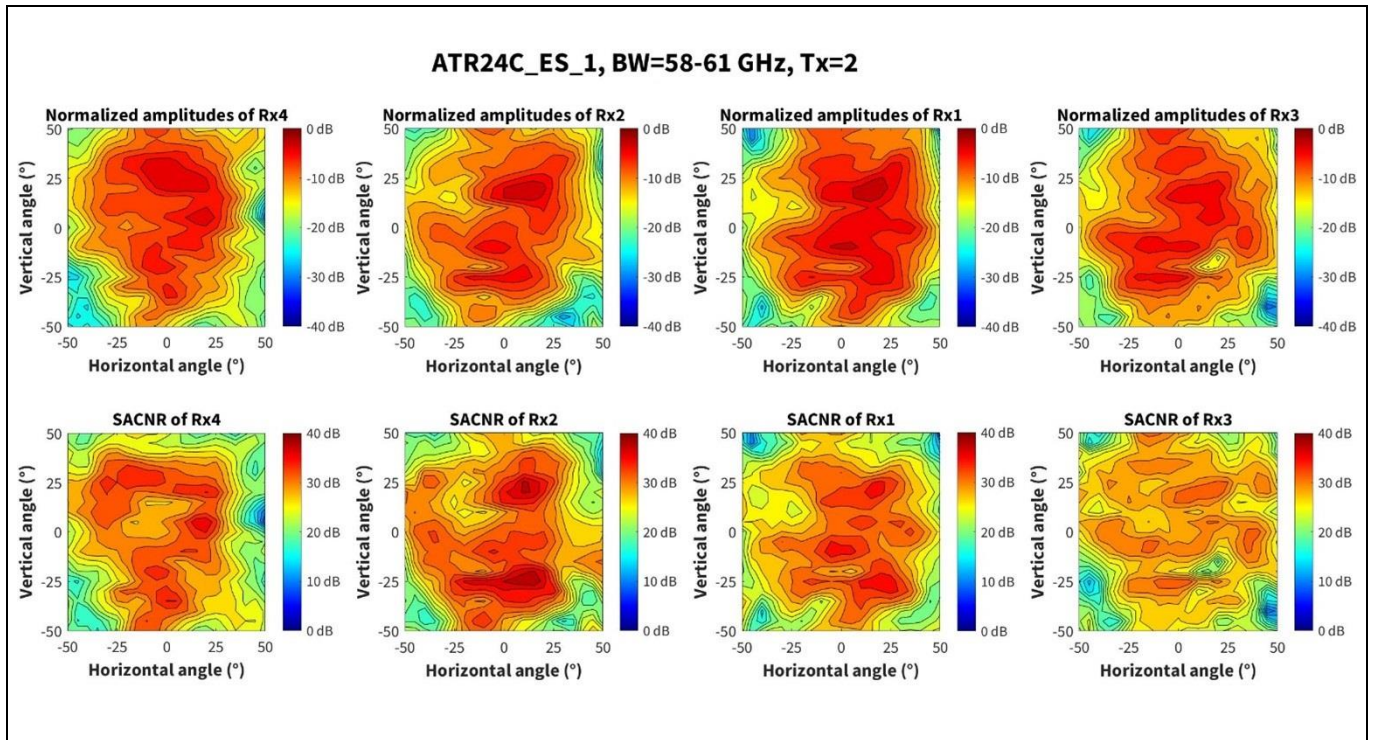

Figure 9 Amplitude and SACNR characteristics with Tx2 channel for 58 to 61 GHz band

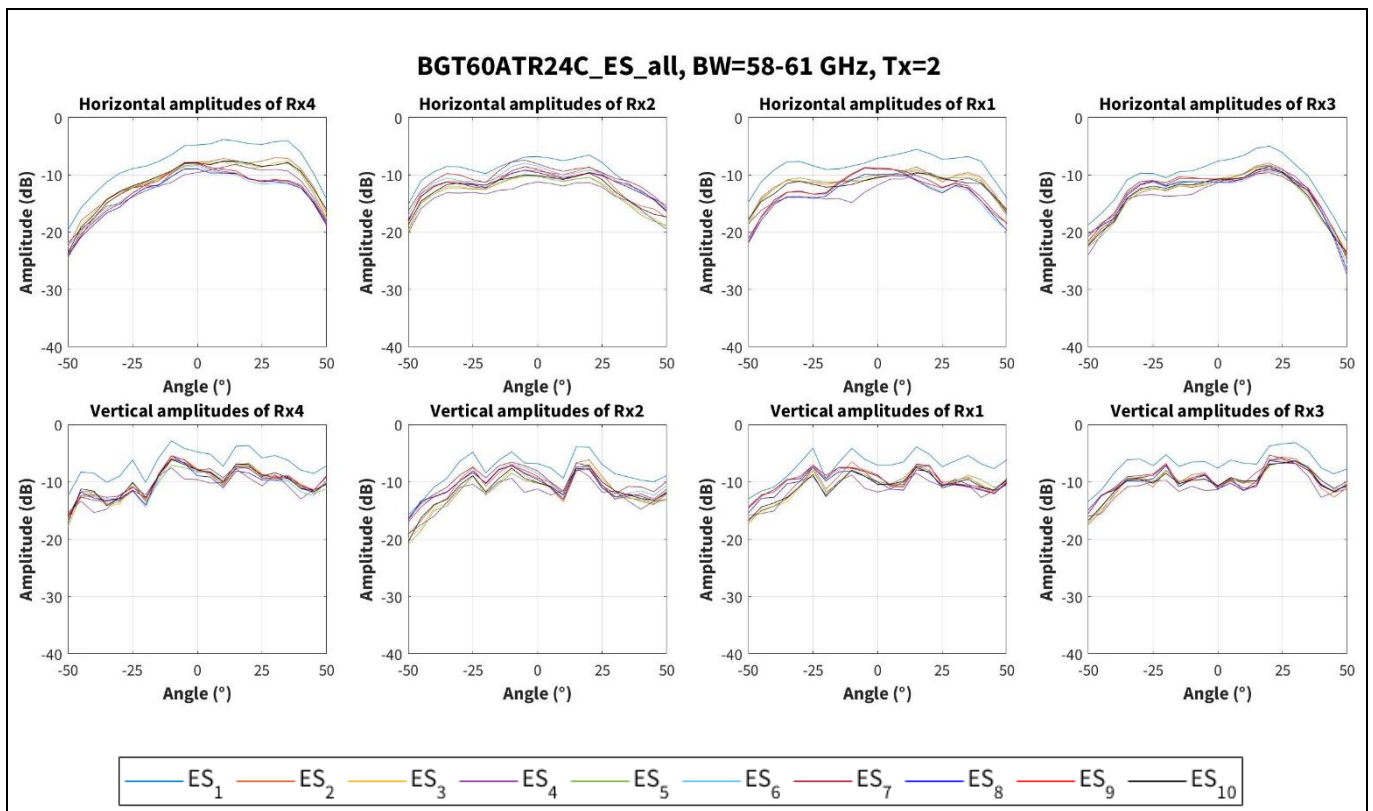

Figure 10 Amplitude characteristics on horizontal and vertical cross-section with Tx2 channel for 58 to 61 GHz band for 10 boards

BGT60ATR24C ES shield characterization

XENSIV™ 60 GHz radar system platform

3 Amplitude characterization

3.1.2 58.5 to 61.5 GHz

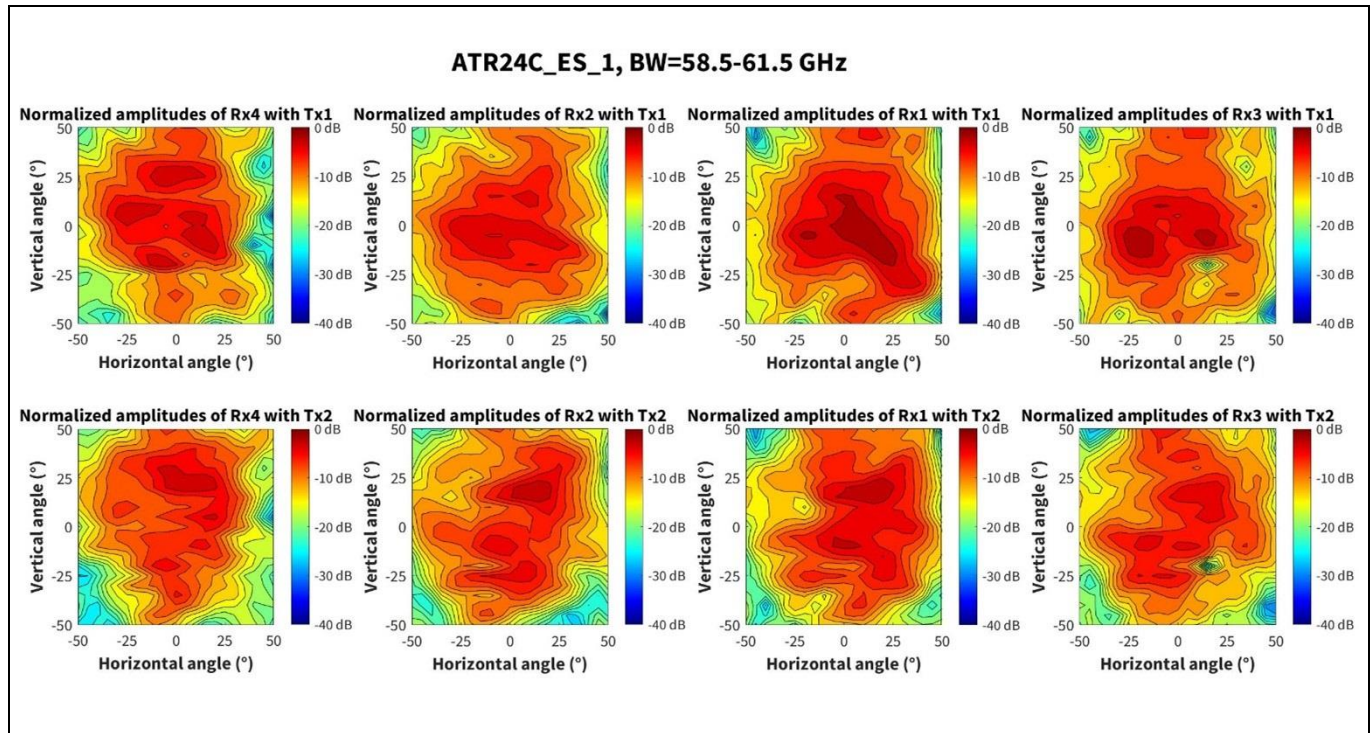

Figure 11 Amplitude characteristics of all virtual antennas for 58.5 to 61.5 GHz band

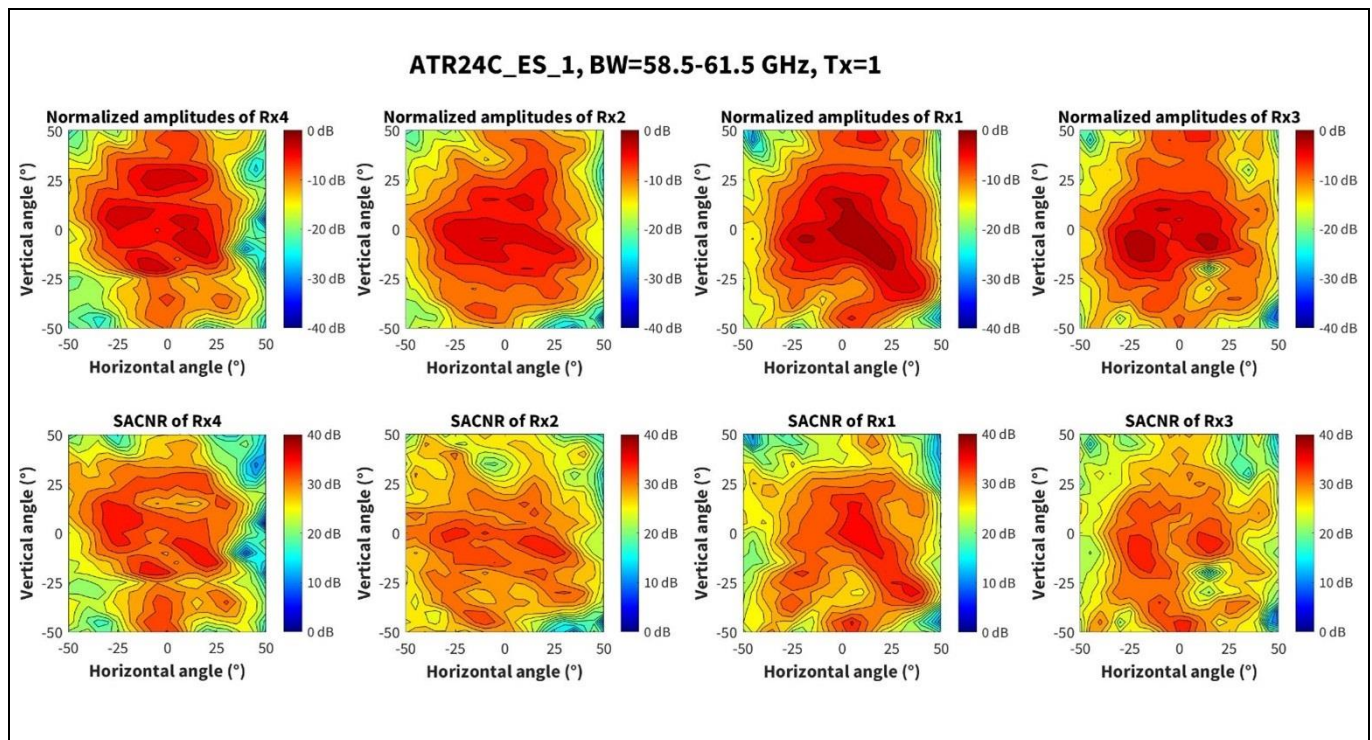

Figure 12 Amplitude and SACNR characteristics with Tx1 channel for 58.5 to 61.5 GHz band

BGT60ATR24C ES shield characterization

XENSIV™ 60 GHz radar system platform

3 Amplitude characterization

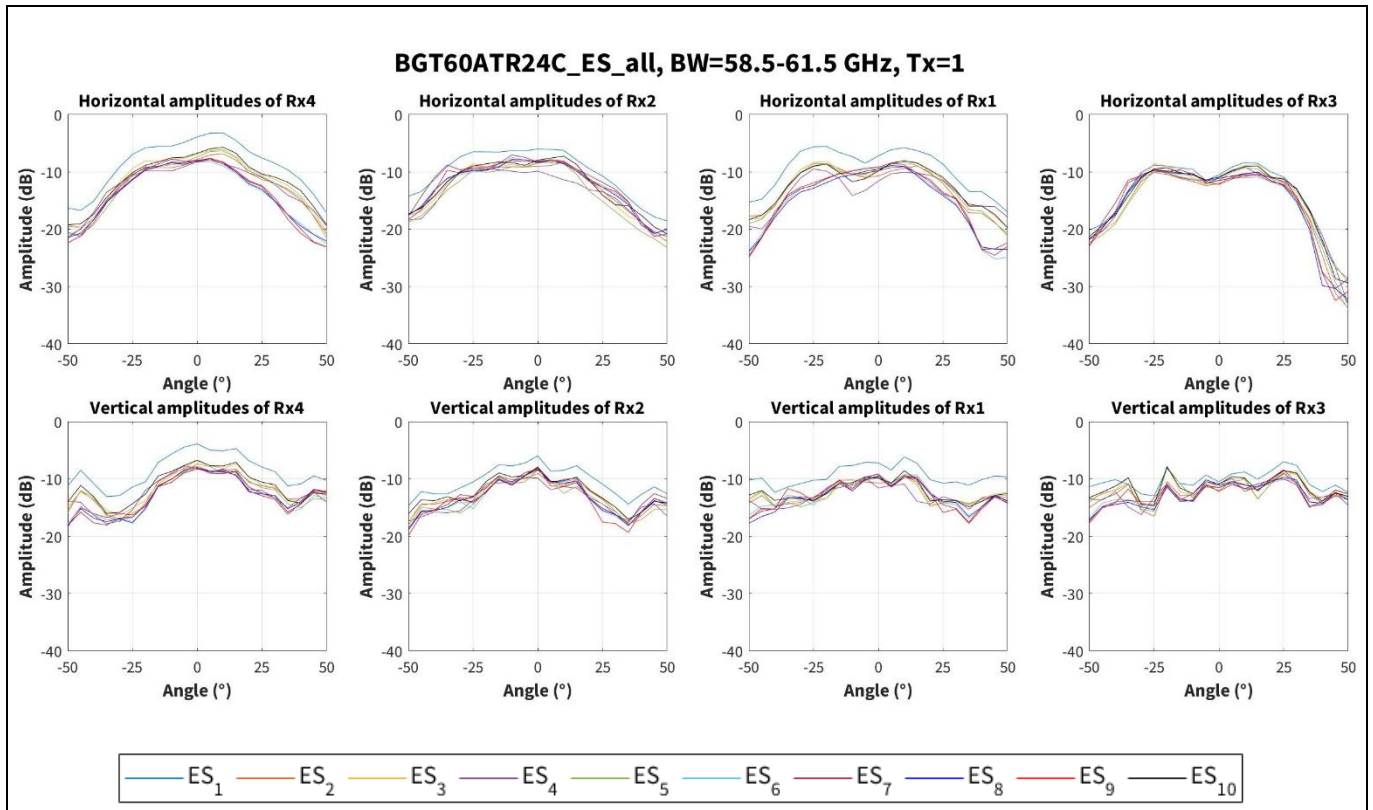

Figure 13 Amplitude characteristics on horizontal and vertical cross-sections with Tx1 channel for 58.5 to 61.5 GHz band for 10 boards

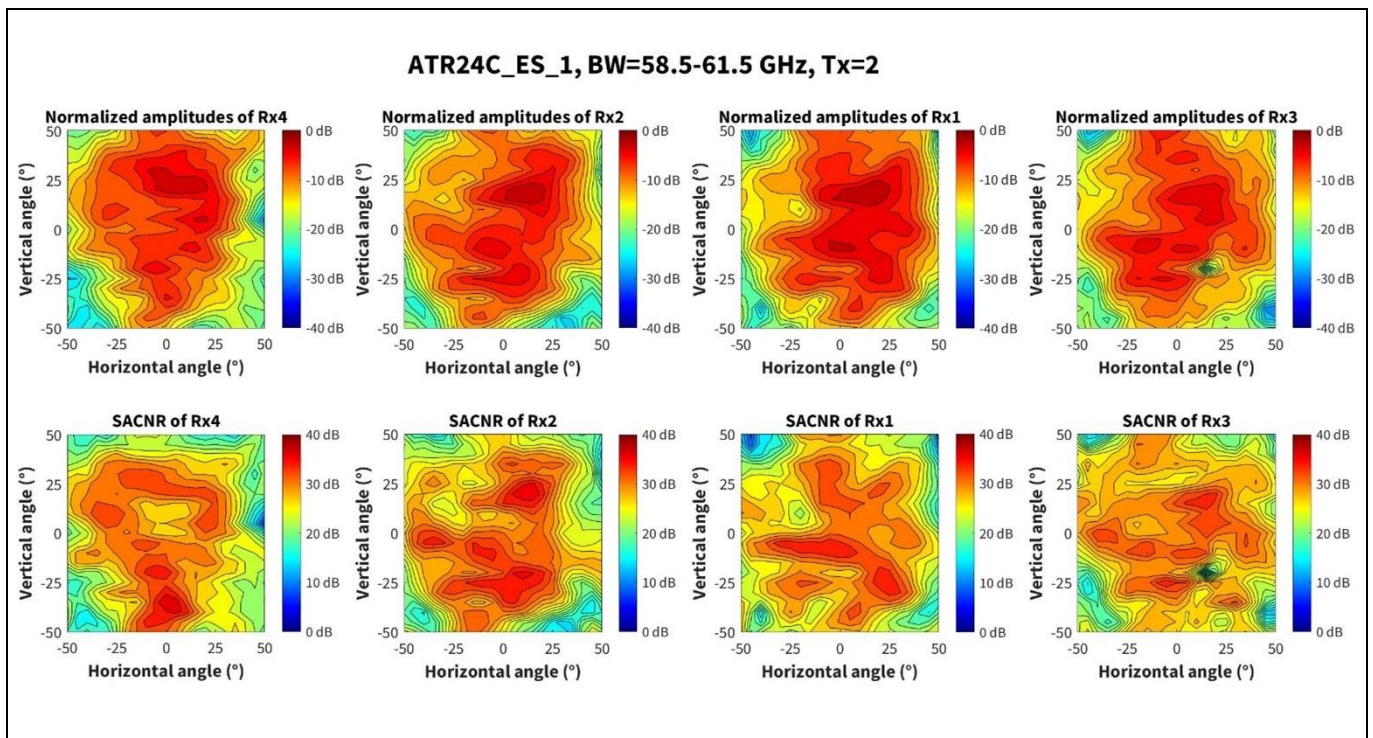

Figure 14 Amplitude and SACNR characteristics with Tx2 channel for 58.5 to 61.5 GHz band

BGT60ATR24C ES shield characterization

XENSIV™ 60 GHz radar system platform

3 Amplitude characterization

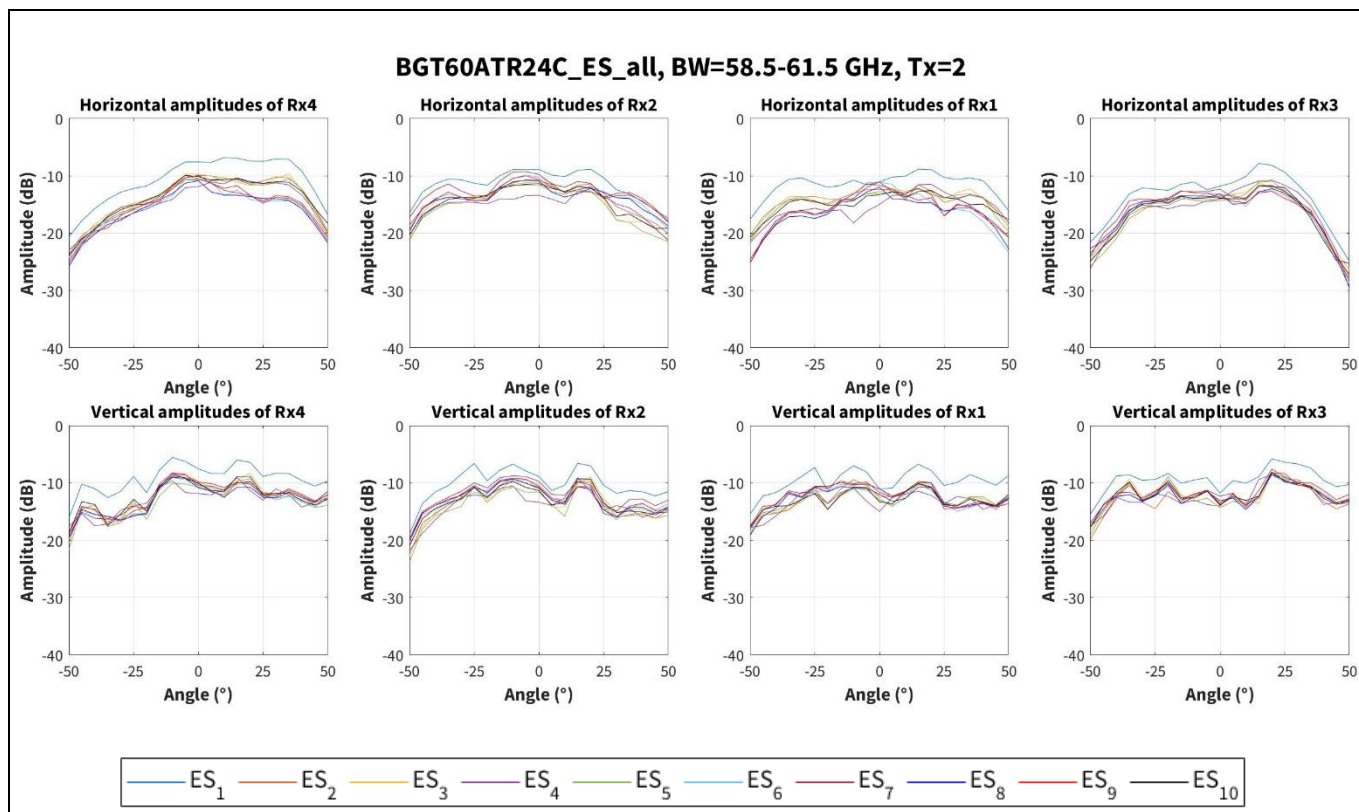

Figure 15 Amplitude characteristics on horizontal and vertical cross-sections with Tx2 channel for 58.5 to 61.5 GHz band for 10 boards

3.1.3 59 to 62 GHz

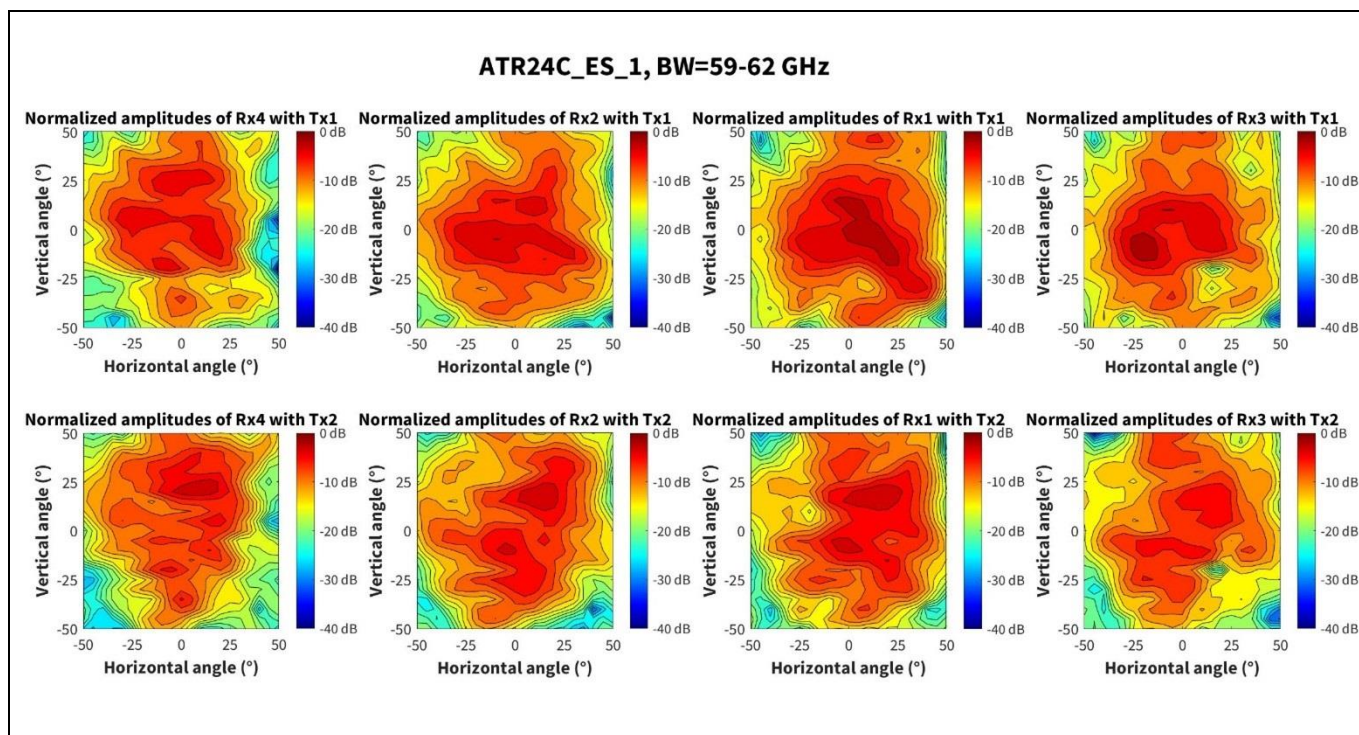

Figure 16 Amplitude characteristics of all virtual antennas for 59 to 62 GHz band

BGT60ATR24C ES shield characterization

XENSIV™ 60 GHz radar system platform

3 Amplitude characterization

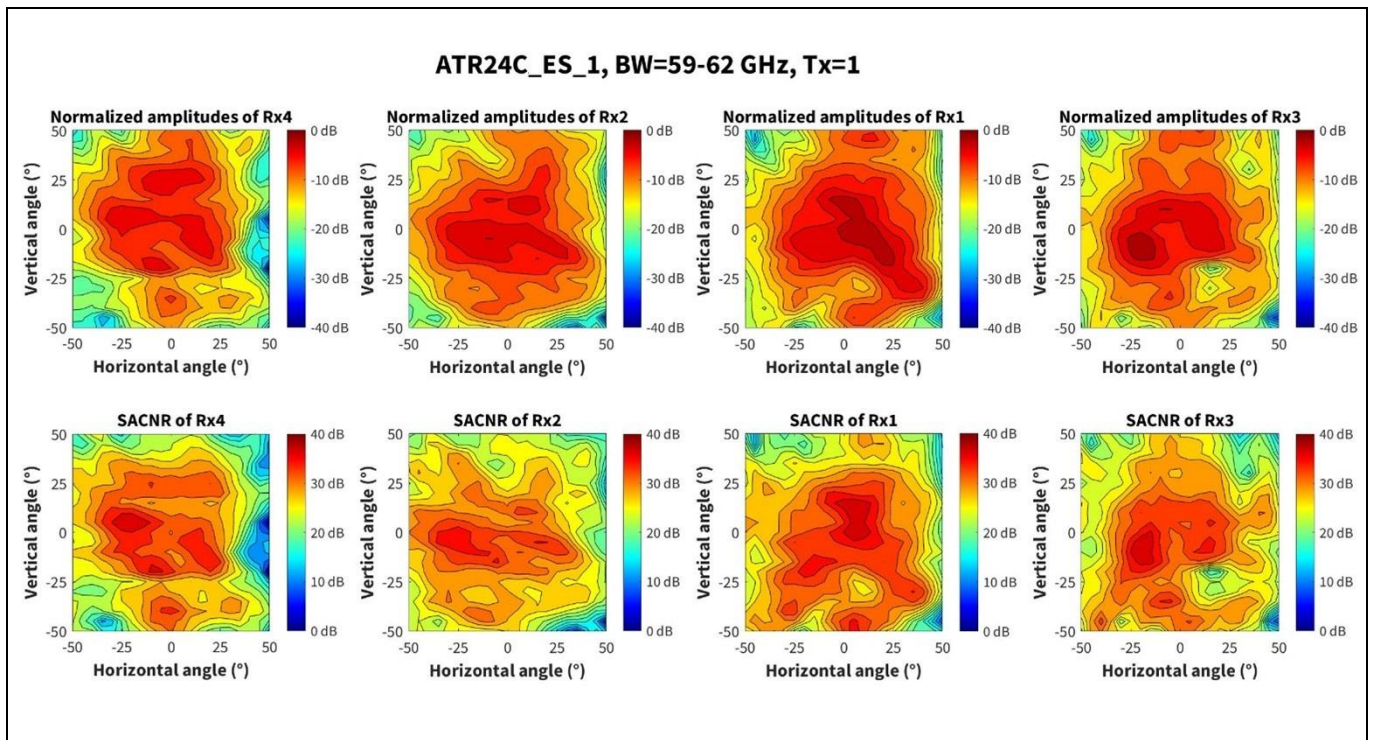

Figure 17 Amplitude and SACNR characteristics with Tx1 channel for 59 to 62 GHz band

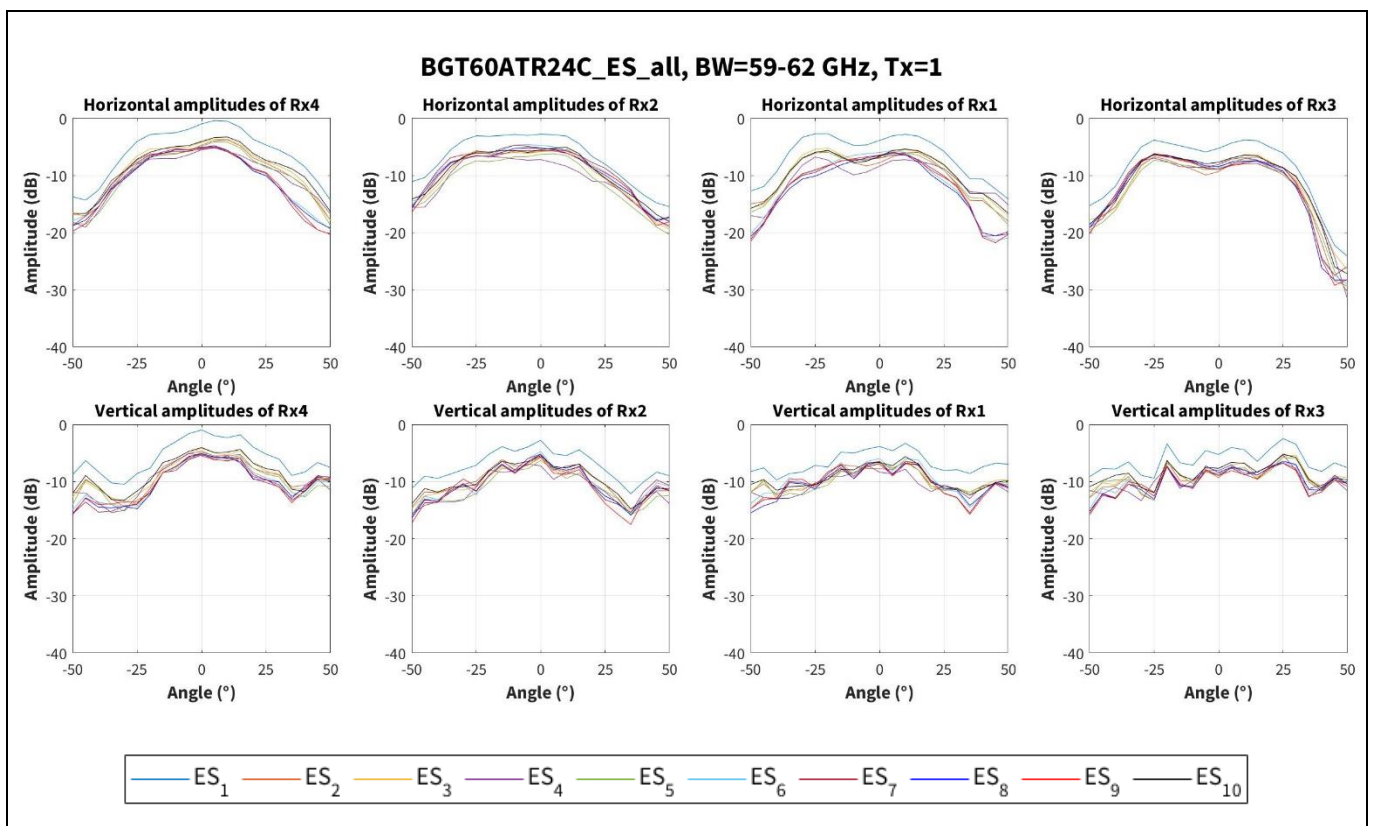

Figure 18 Amplitude characteristics on horizontal and vertical cross-sections with Tx1 channel for 59 to 62 GHz band for 10 boards

BGT60ATR24C ES shield characterization

XENSIV™ 60 GHz radar system platform

3 Amplitude characterization

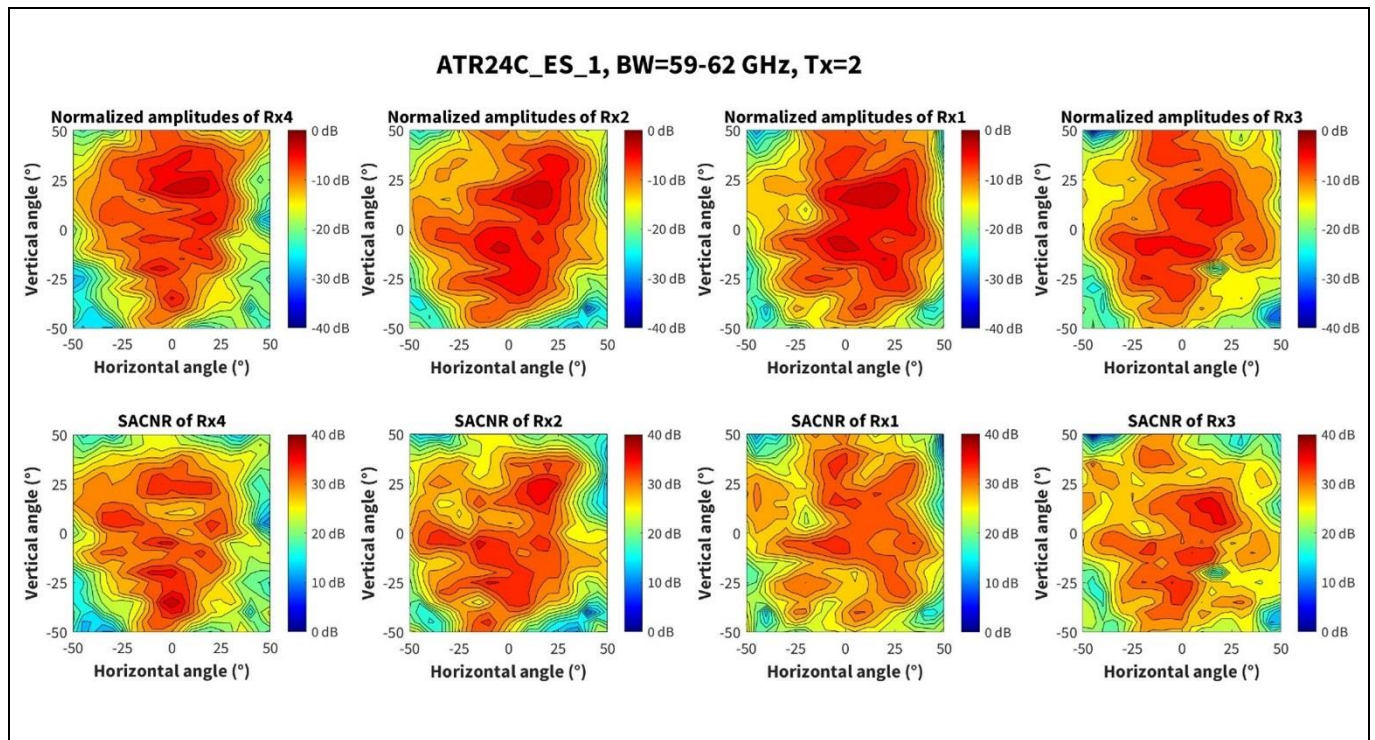

Figure 19 Amplitude and SACNR characteristics with Tx2 channel for 59 to 62 GHz band

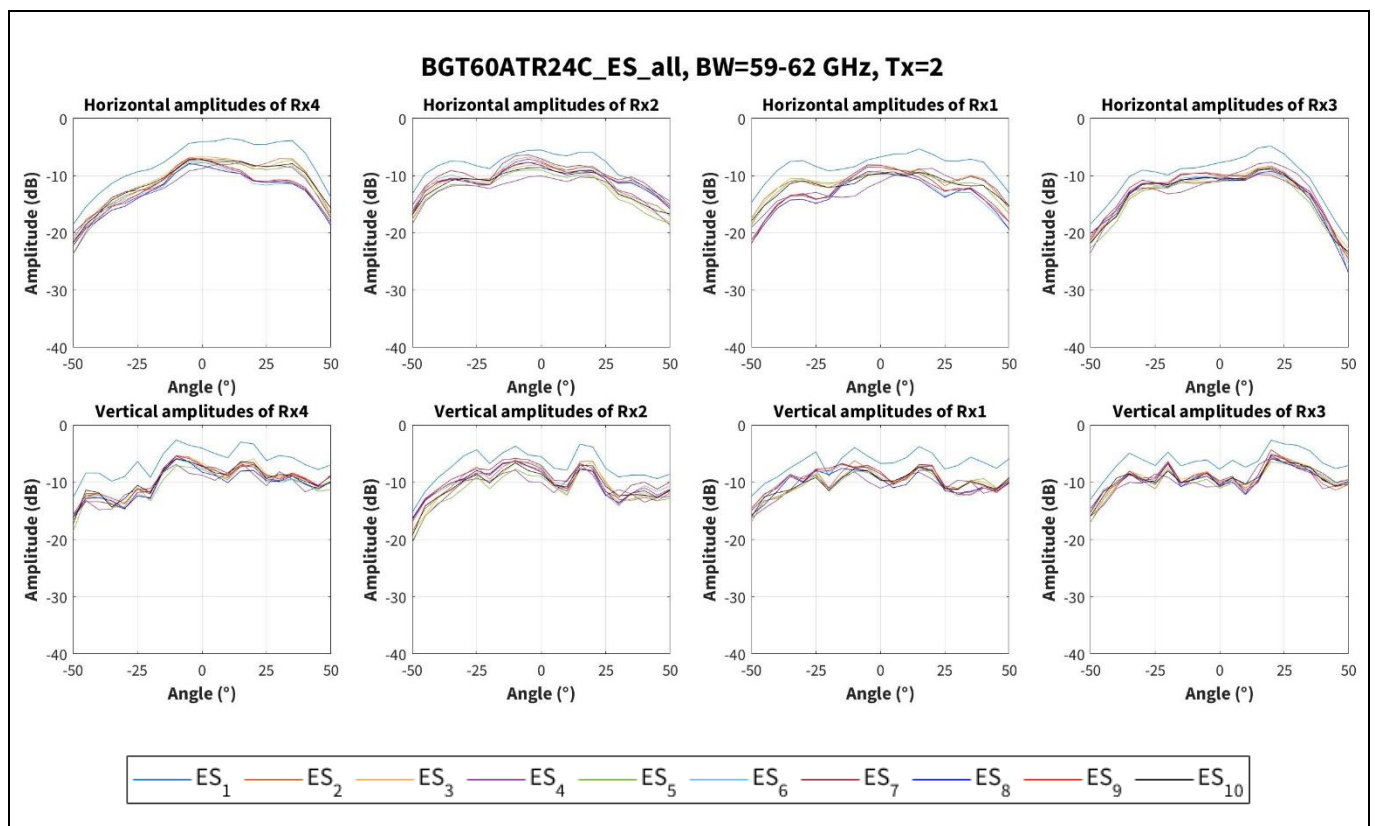

Figure 20 Amplitude characteristics on horizontal and vertical cross-sections with Tx2 channel for 59 to 62 GHz band for 10 boards

BGT60ATR24C ES shield characterization

XENSIV™ 60 GHz radar system platform

3 Amplitude characterization

3.1.4 58 to 62 GHz

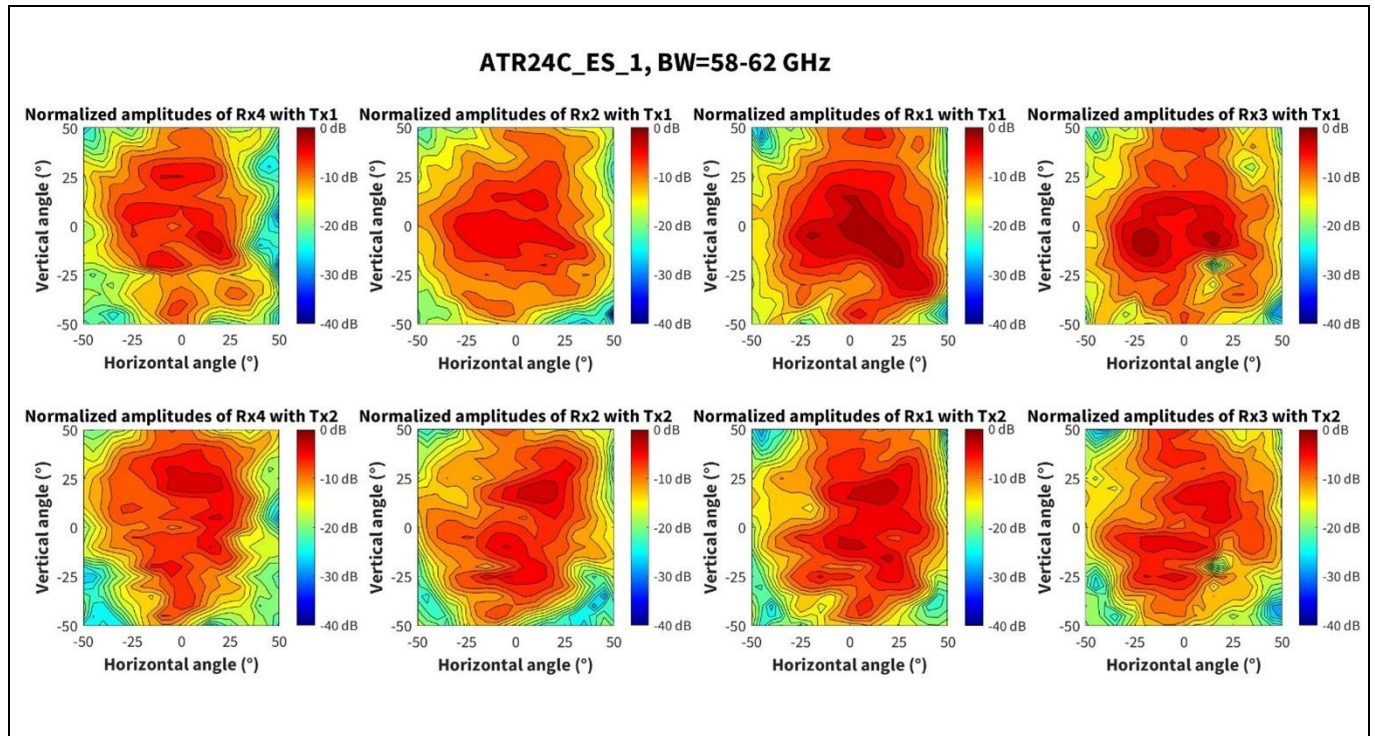

Figure 21 Amplitude characteristics of all virtual antennas for 58 to 62 GHz band

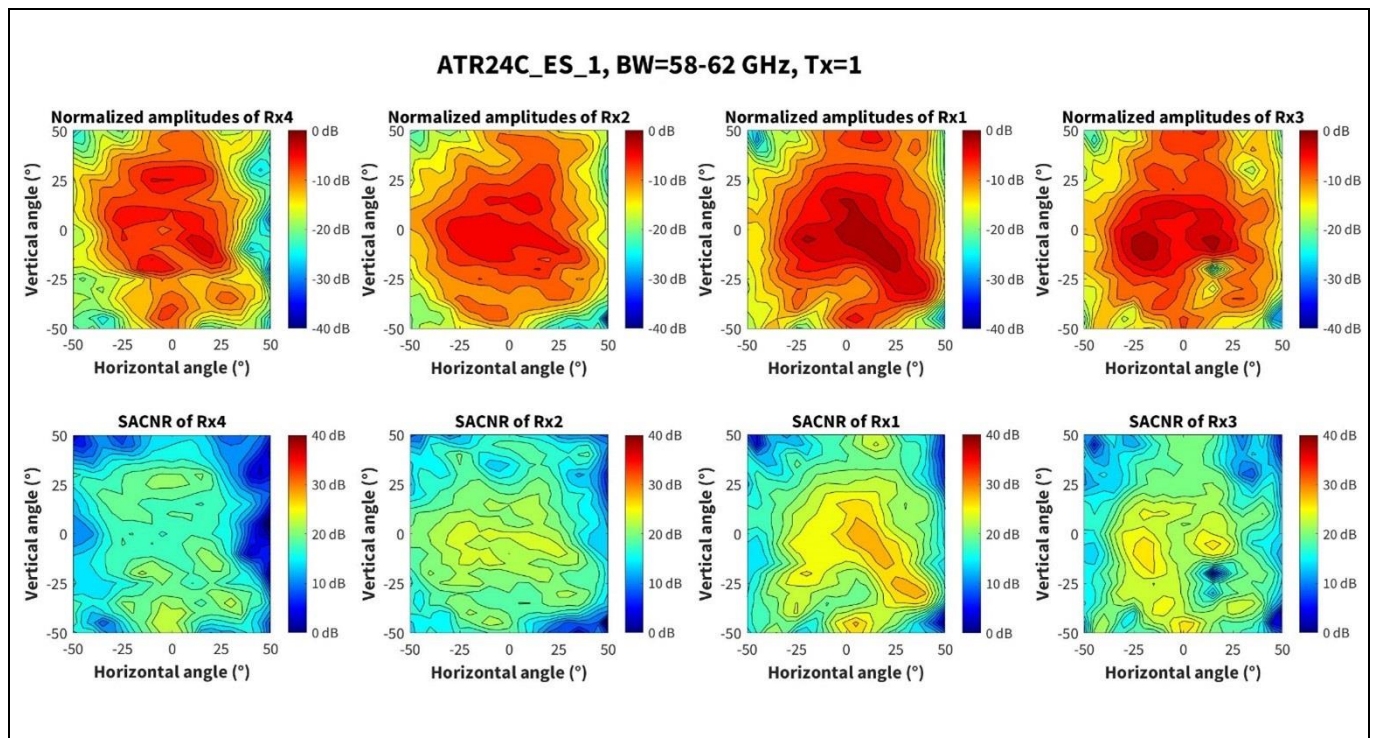

Figure 22 Amplitude and SACNR characteristics with Tx1 channel for 58 to 62 GHz band

BGT60ATR24C ES shield characterization

XENSIV™ 60 GHz radar system platform

3 Amplitude characterization

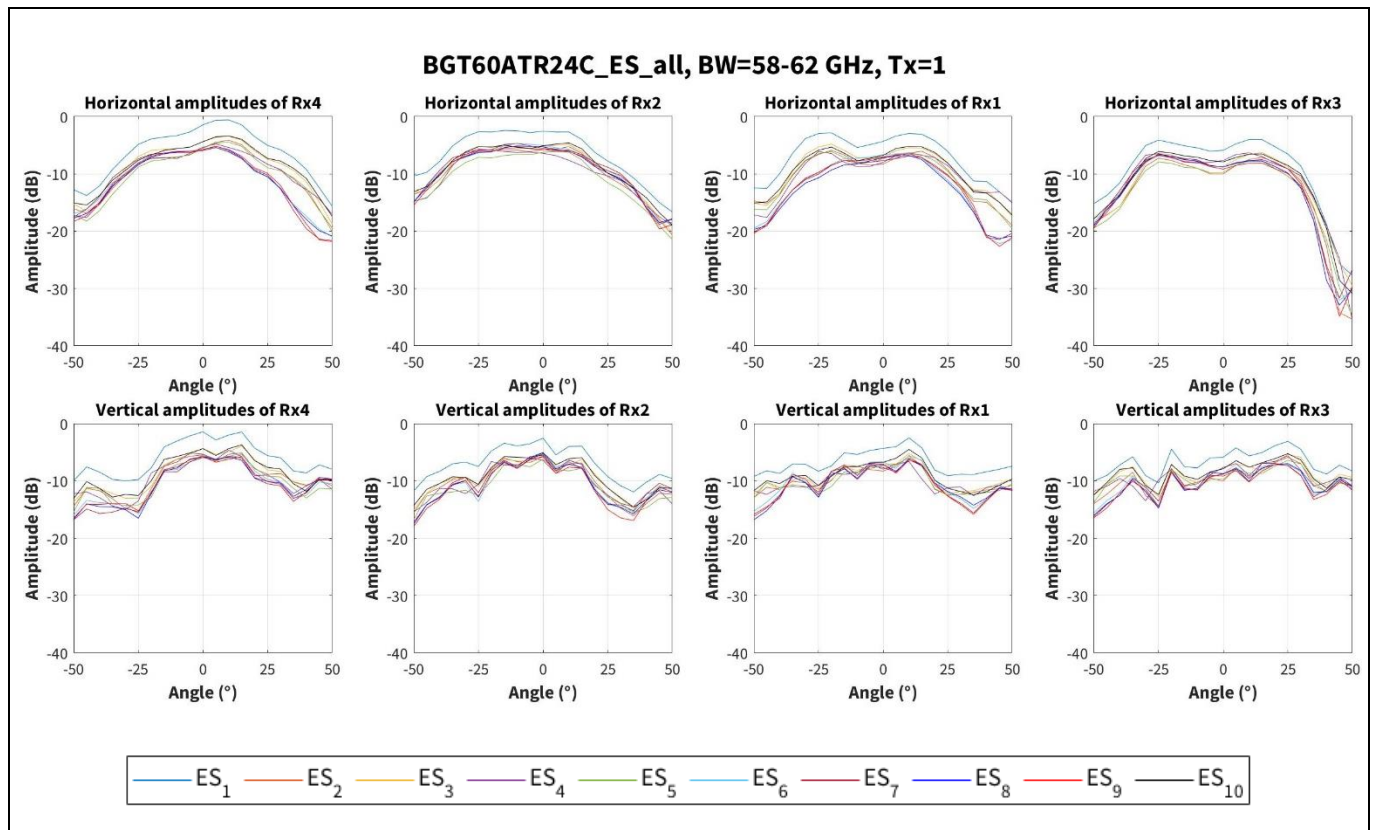

Figure 23 Amplitude characteristics on horizontal and vertical cross-sections with Tx1 channel for 58 to 62 GHz band for 10 boards

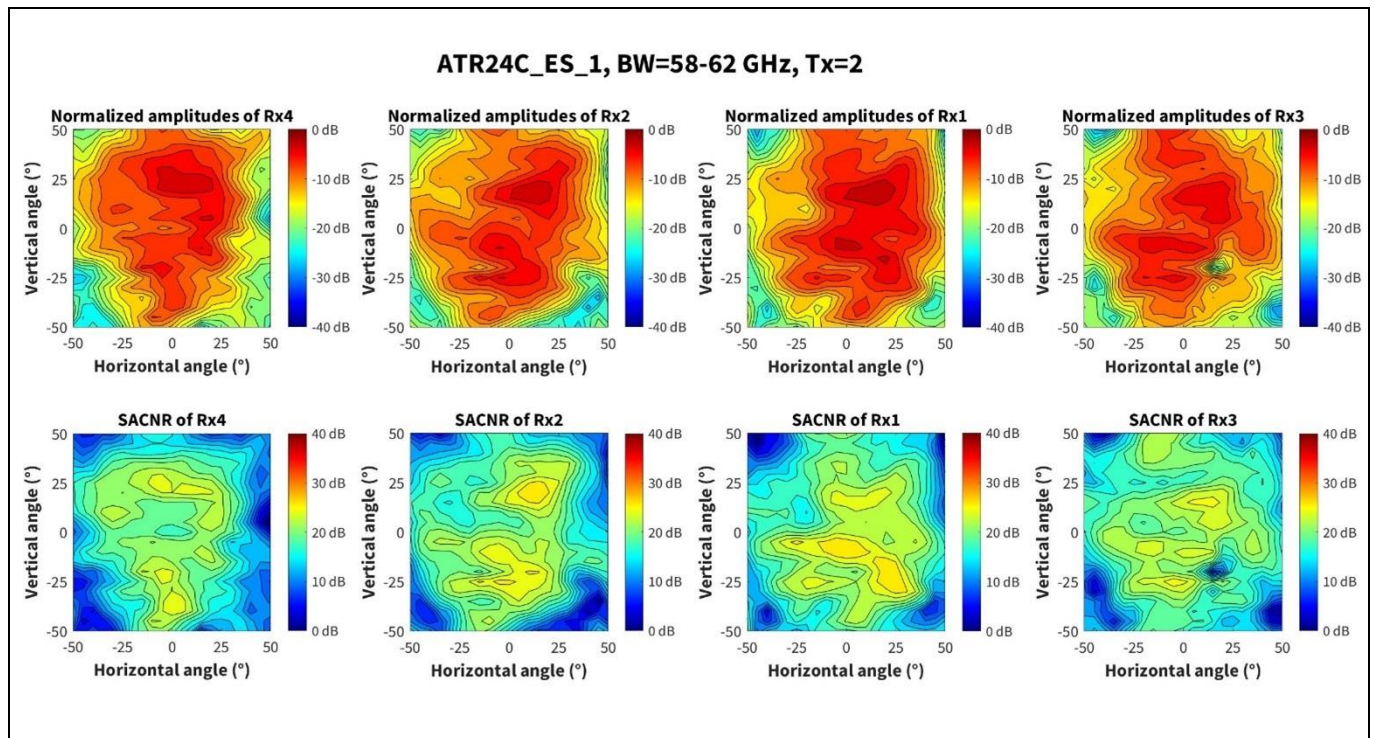

Figure 24 Amplitude and SACNR characteristics with Tx2 channel for 58 to 62 GHz band

BGT60ATR24C ES shield characterization

XENSIV™ 60 GHz radar system platform

3 Amplitude characterization

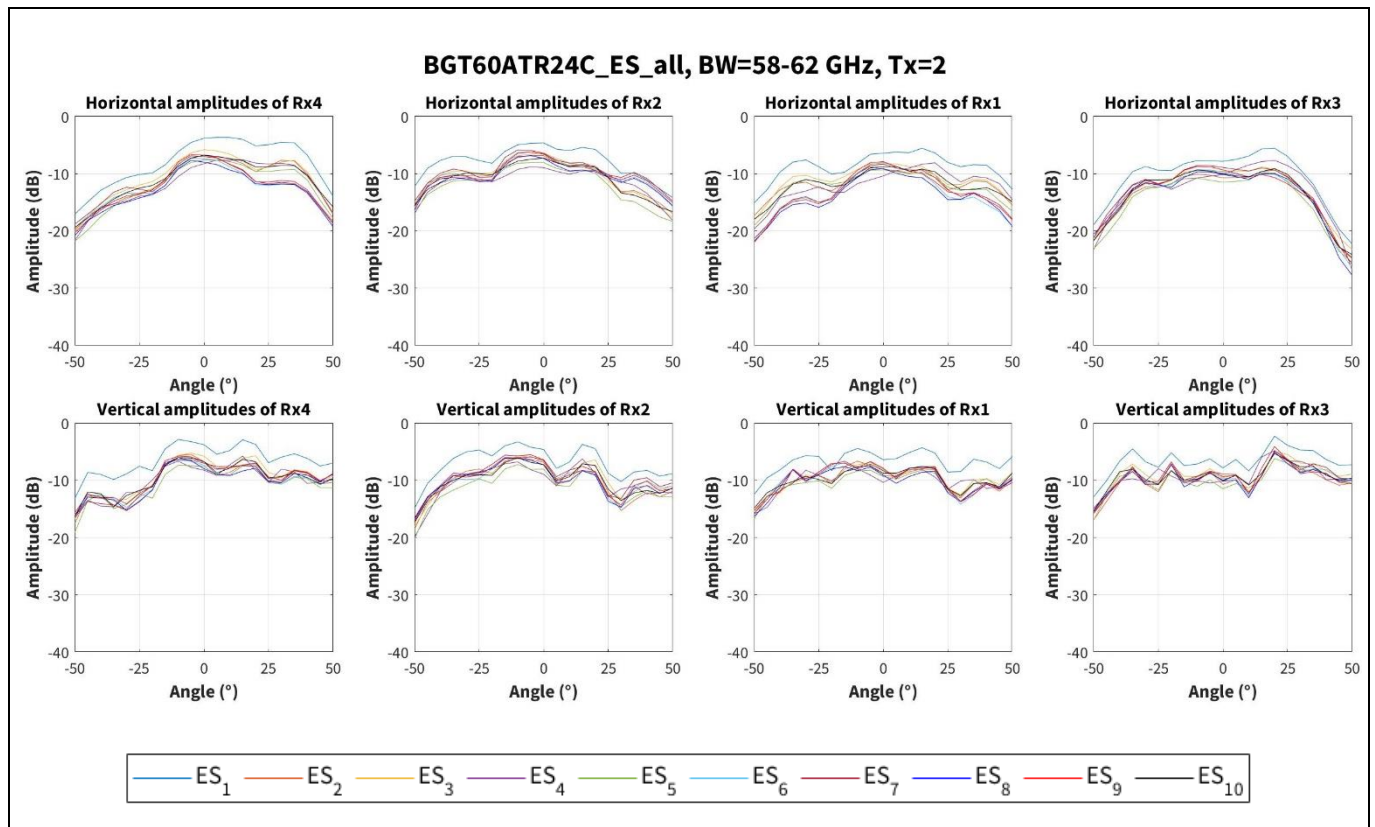

Figure 25 Amplitude characteristics on horizontal and vertical cross-sections with Tx2 channel for 58 to 62 GHz band for 10 boards

3.2 Amplitude characteristics over frequency

Figure 26 through to Figure 29 show amplitude characteristics over different frequency bands with the results of 10 different boards. Each plot compares the results of horizontal and vertical cross-sections of both Tx antennas for each Rx antenna.

BGT60ATR24C ES shield characterization

XENSIV™ 60 GHz radar system platform

3 Amplitude characterization

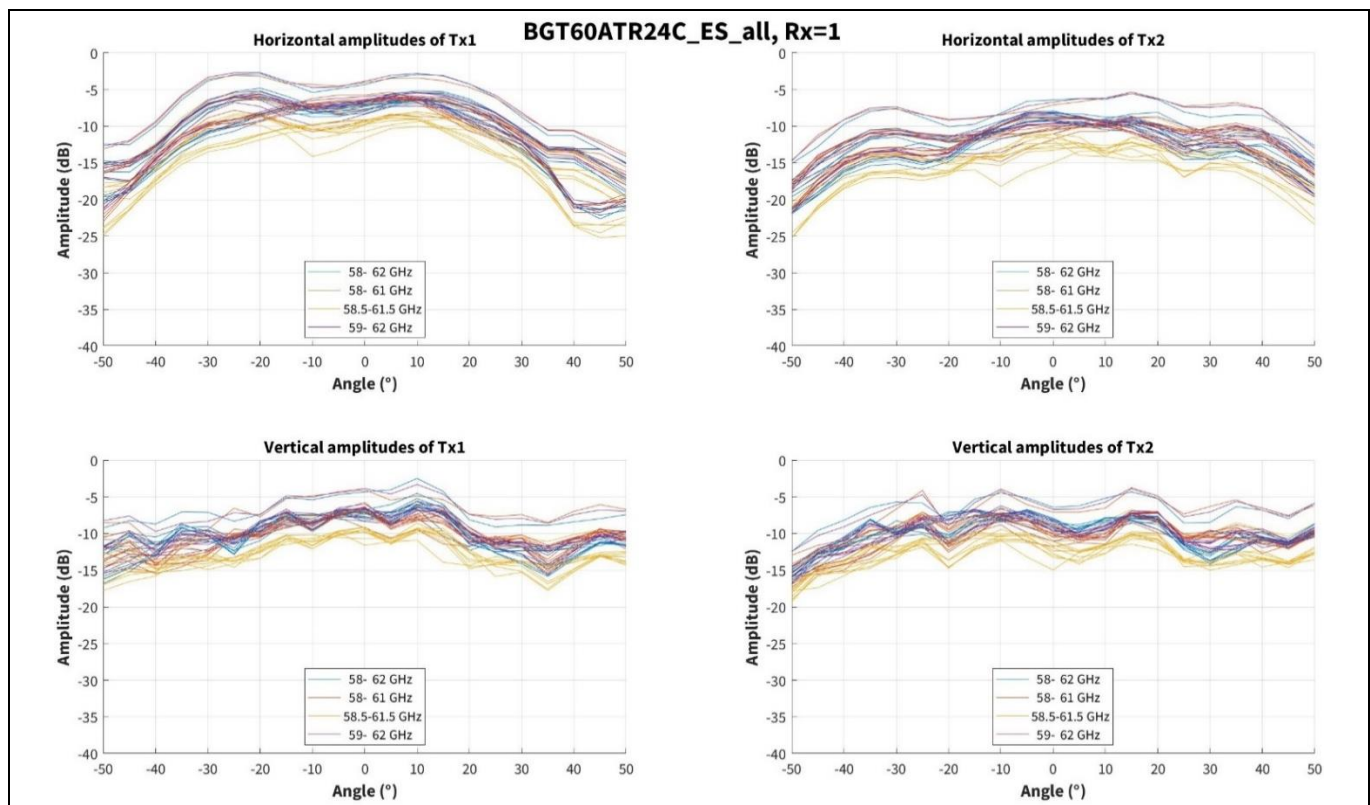

Figure 26 Amplitude characteristics on horizontal and vertical cross-sections with Rx1 channel for all frequency bands and 10 boards

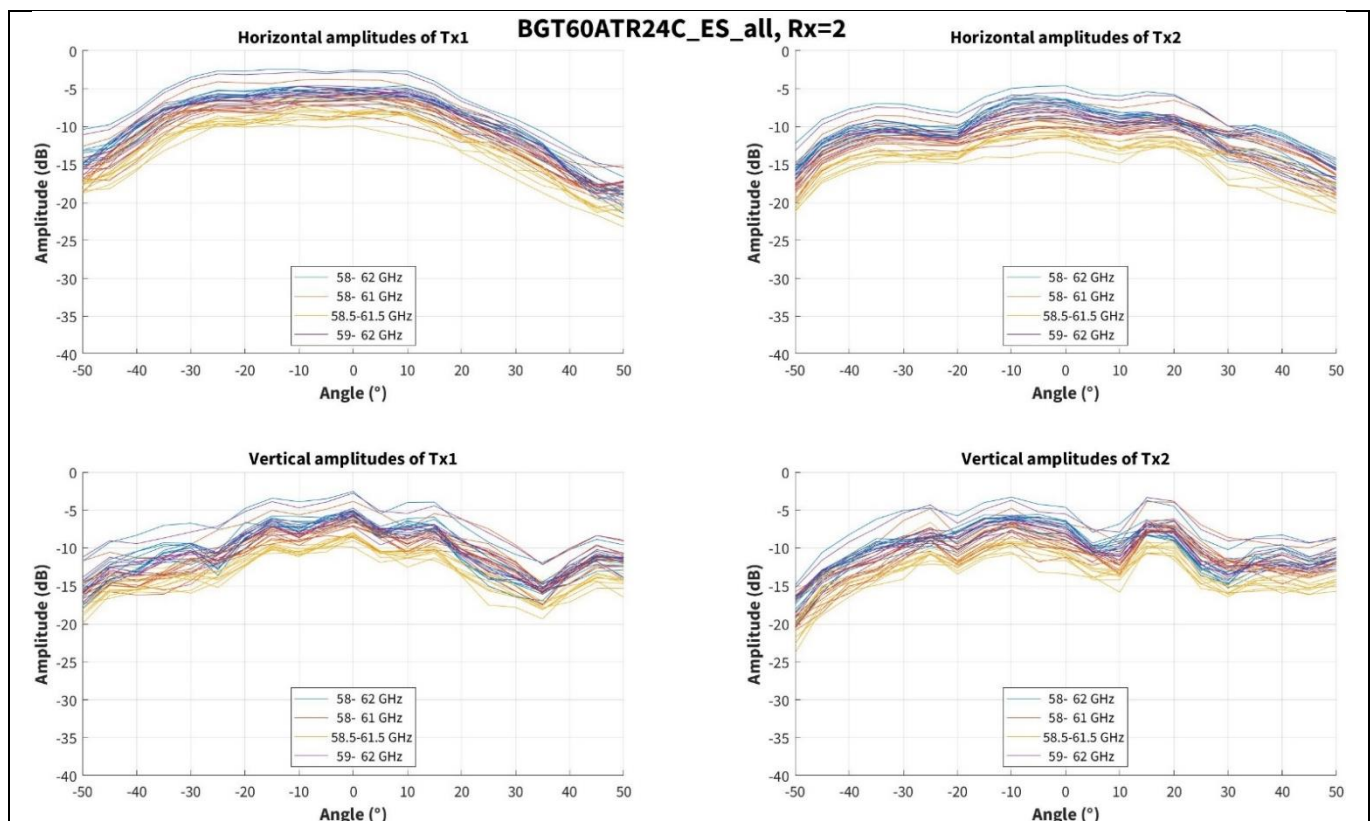

Figure 27 Amplitude characteristics on horizontal and vertical cross-sections with Rx2 channel for all frequency bands and 10 boards

BGT60ATR24C ES shield characterization

XENSIV™ 60 GHz radar system platform

3 Amplitude characterization

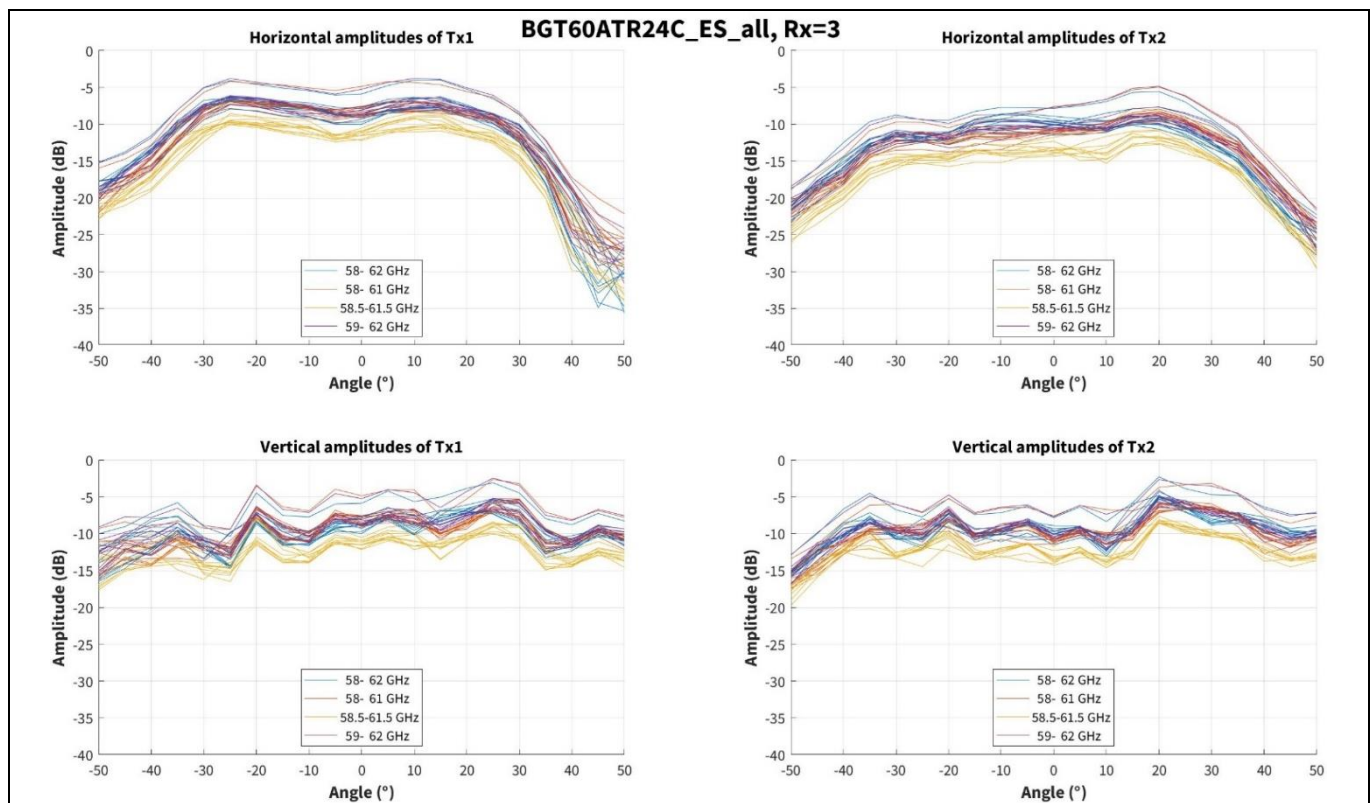

Figure 28 Amplitude characteristics on horizontal and vertical cross-sections with Rx3 channel for all frequency bands and 10 boards

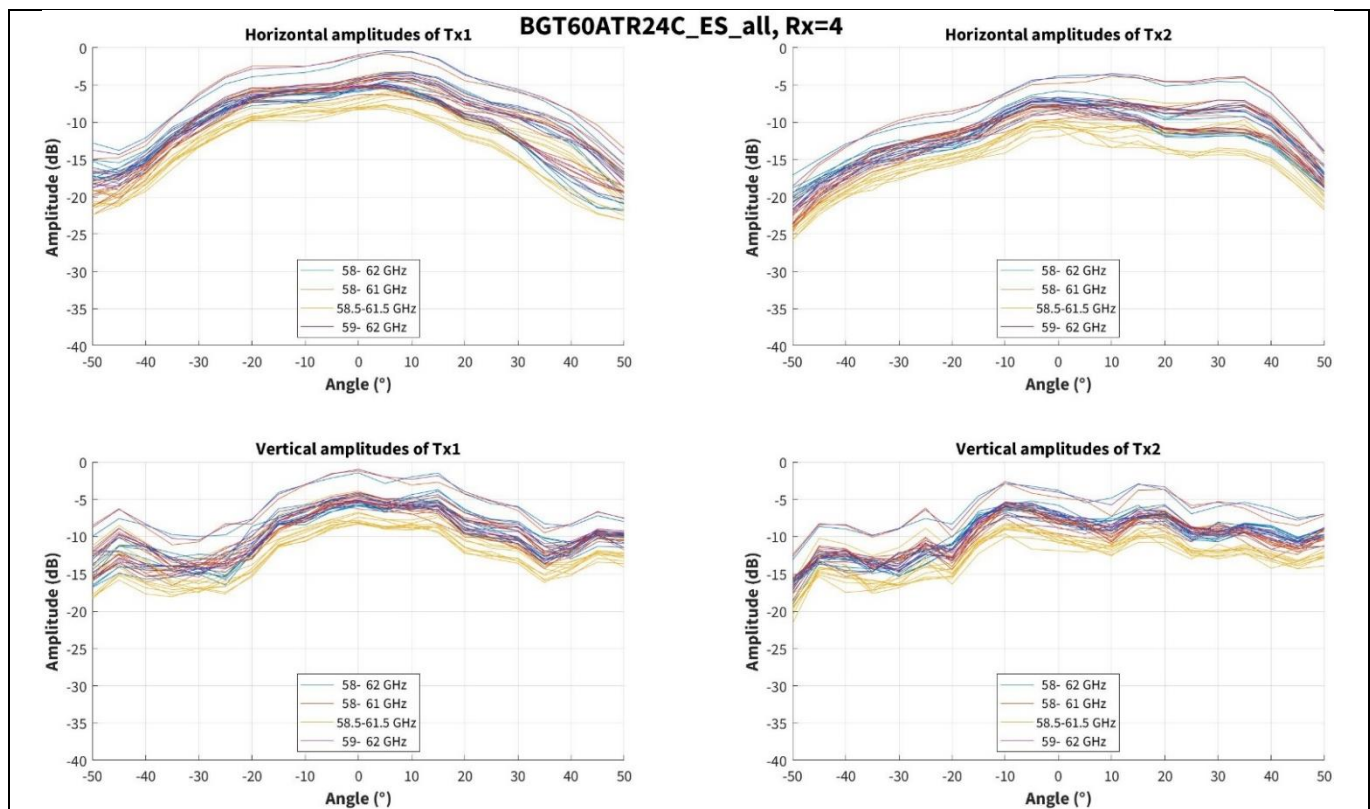

Figure 29 Amplitude characteristics on horizontal and vertical cross-sections with Rx4 channel for all frequency bands and 10 boards

BGT60ATR24C ES shield characterization

XENSIV™ 60 GHz radar system platform

3 Amplitude characterization

3.3 Half-power beam width

Using the measured amplitude characteristics at the 58 to 62 GHz band, half-power beam width (HPBW) values for the E-plane (vertical) and H-plane (horizontal) are calculated as in Figure 30. The measured data for eight virtual antenna elements and 10 boards is averaged to obtain data points on horizontal and vertical planes. The beam characteristics for the E-plane and H-plane are plotted in Figure 30 by fitting curves to the averaged data points.

The resultant HPBW is 80 degrees for the H-plane and 100 degrees for the E-plane.

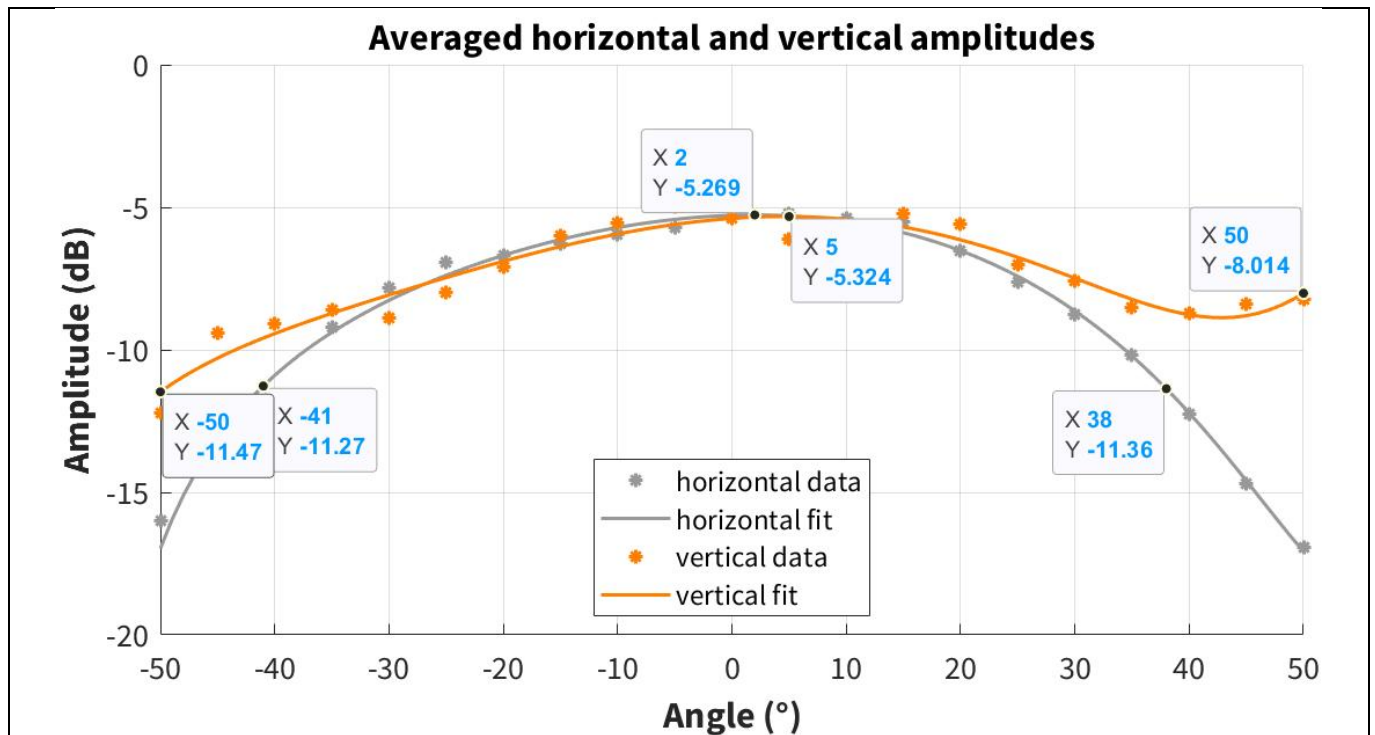

Figure 30 Averaged horizontal and vertical amplitudes and HPBW values for E-plane and H-plane

4 Angle estimation

4 Angle estimation

4.1 Direction of arrival estimation

Using the phase information from the virtual antennas, the direction of arrival (DoA) of the reflection is estimated. A conventional 2D beamforming algorithm is used on a test grid of -90 degrees, to +90 degrees with 1-degree steps for azimuth and elevation angles. Figure 31 shows the angle spectrum output of the beamformer for 0-degree azimuth and 0-degree elevation angle measurements. By taking the peak of the 2D angle spectrum, both azimuth and elevation angles are estimated. This process is repeated for all measured angles.

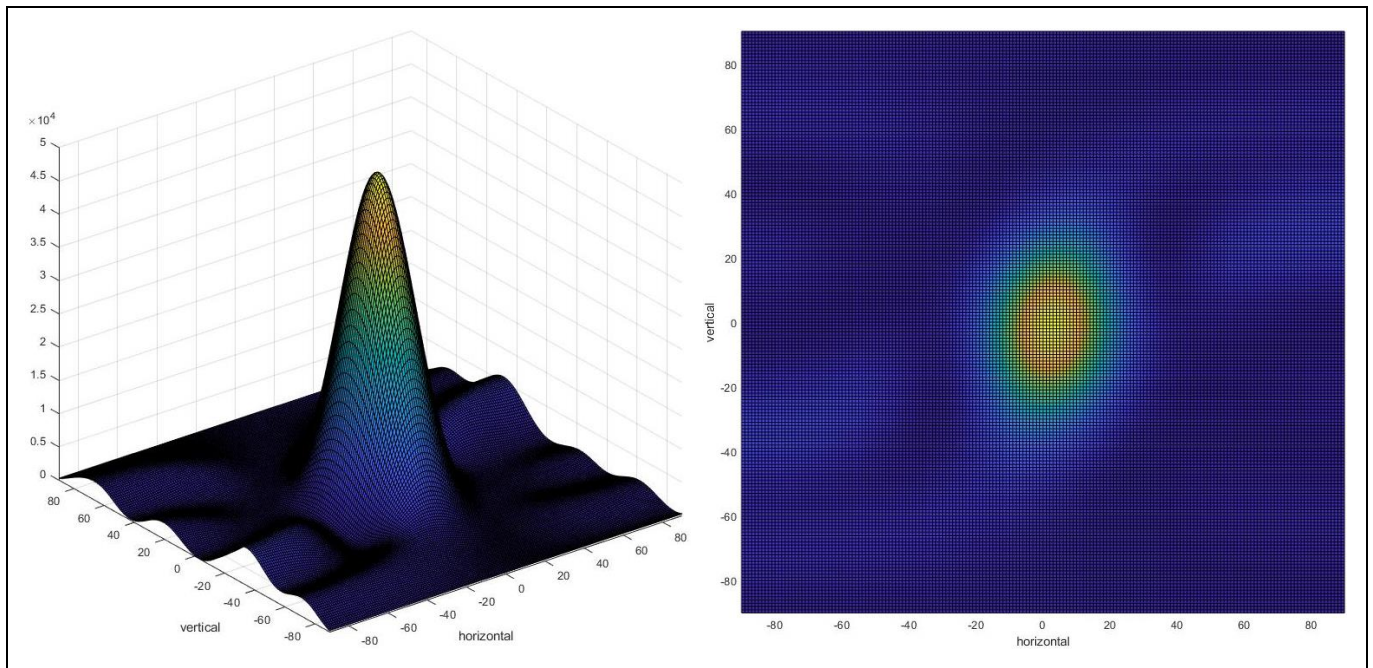

Figure 31 Angle spectrum after 2D beamforming for 0-degree azimuth and 0-degree elevation angle measurement

4.2 Reconstructed angles

This section presents the reconstructed angles for all measured angles for each frequency band, with 3D surface plots and 2D projections. Angle reconstruction errors are also plotted by subtracting calculated angles from the real measurement angles.

BGT60ATR24C ES shield characterization

XENSIV™ 60 GHz radar system platform

4 Angle estimation

4.2.1 58 to 61 GHz

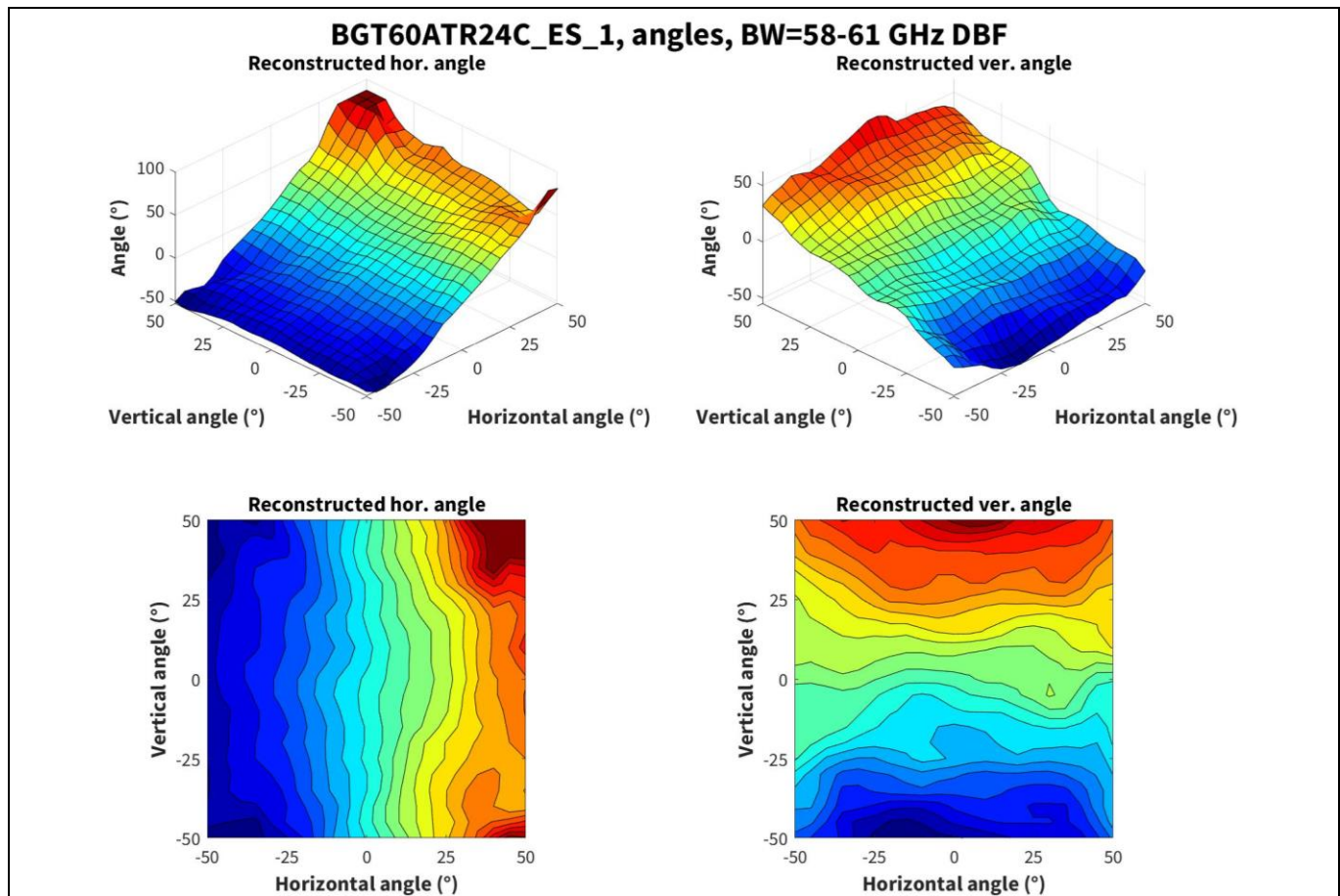

Figure 32 Reconstructed horizontal and vertical angles for 58 to 61 GHz measurements

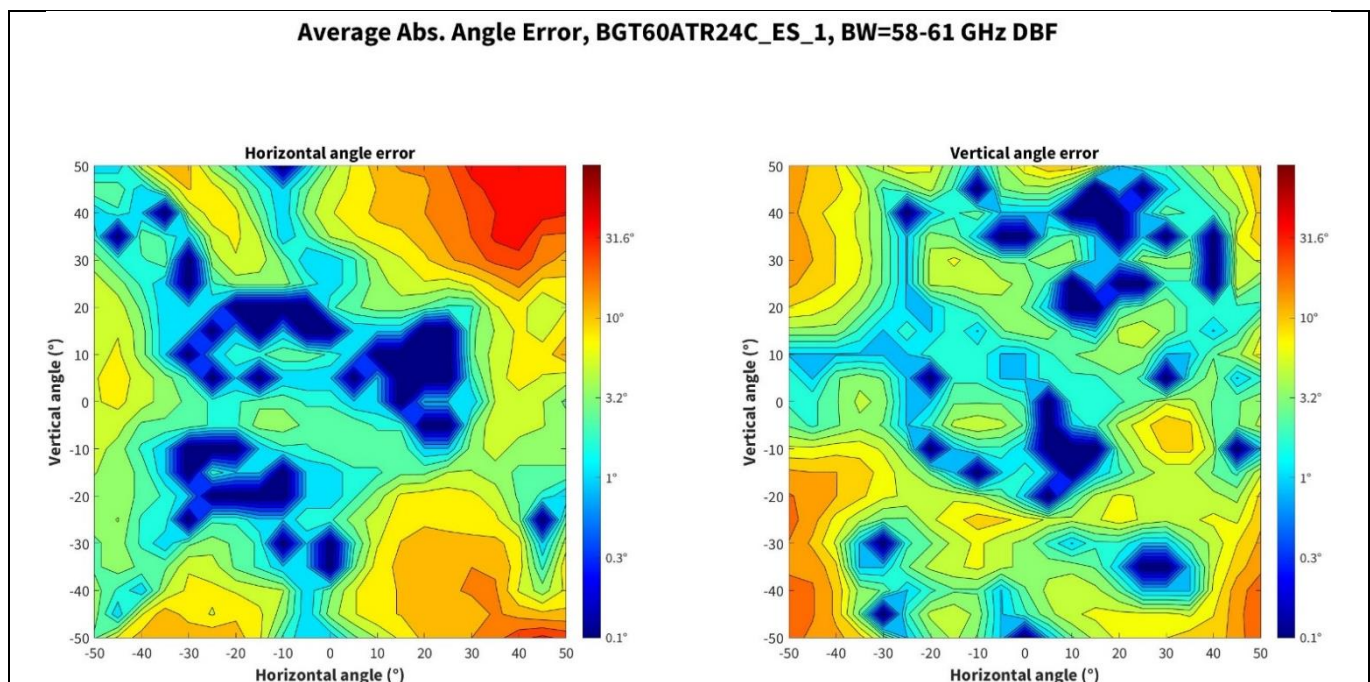

Figure 33 Angle reconstruction errors for 58 to 61 GHz measurements

BGT60ATR24C ES shield characterization

XENSIV™ 60 GHz radar system platform

4 Angle estimation

4.2.2 58.5 to 61.5 GHz

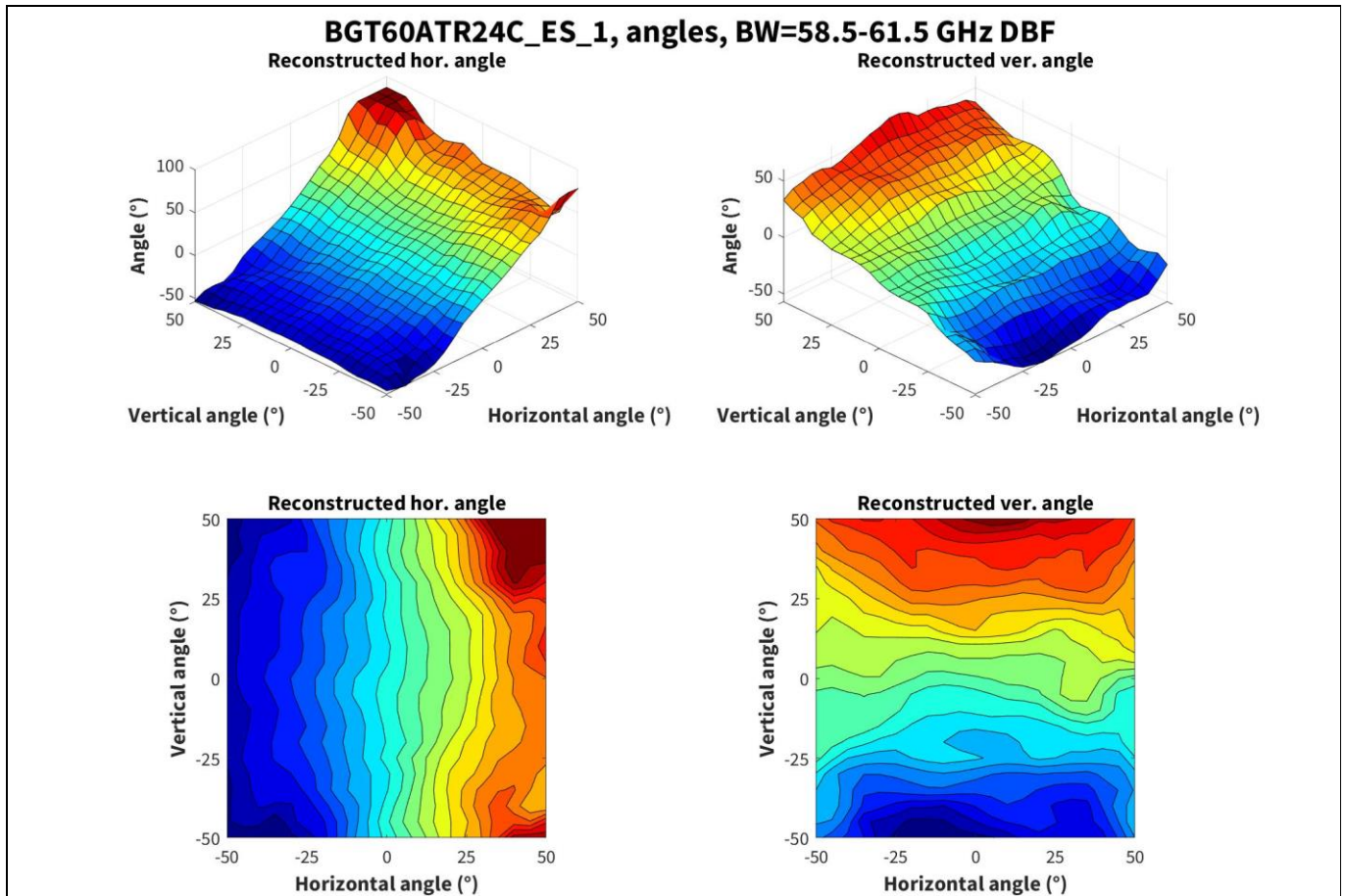

Figure 34 Reconstructed horizontal and vertical angles for 58.5 to 61.5 GHz measurements

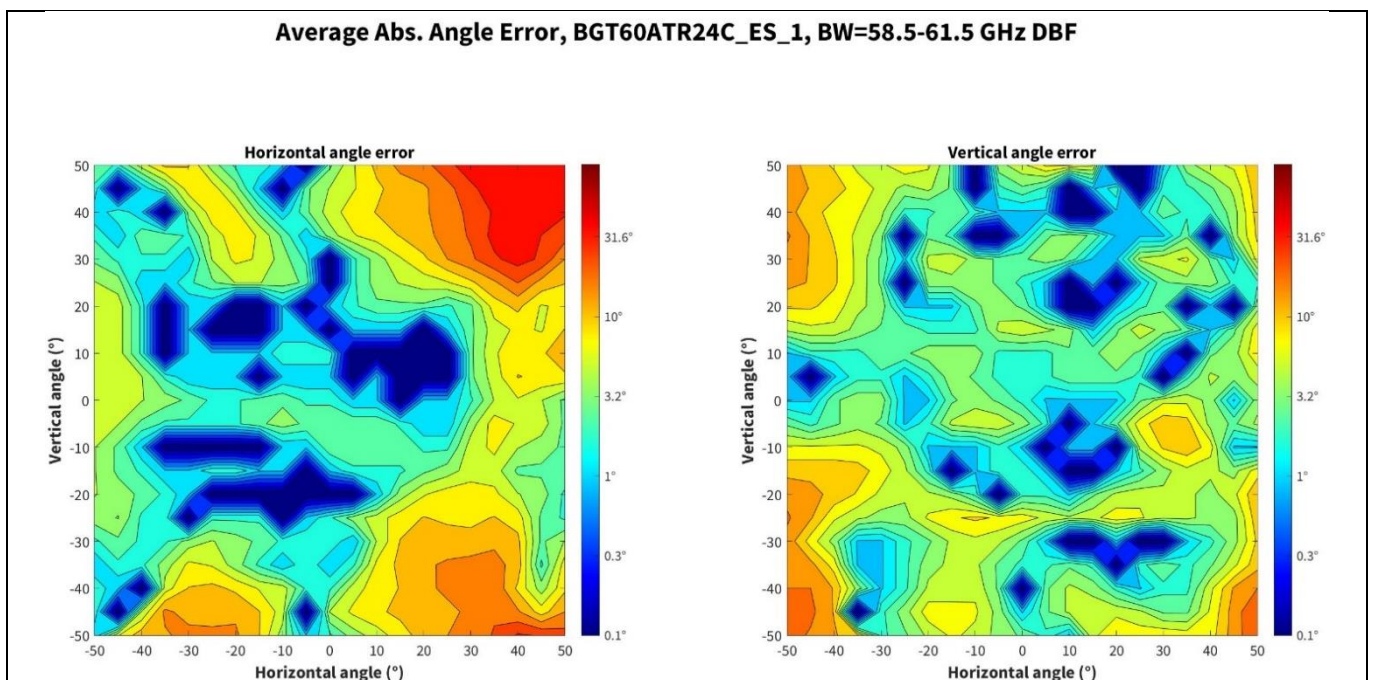

Figure 35 Angle reconstruction errors for 58.5 to 61.5 GHz measurements

BGT60ATR24C ES shield characterization

XENSIV™ 60 GHz radar system platform

4 Angle estimation

4.2.3 59 to 62 GHz

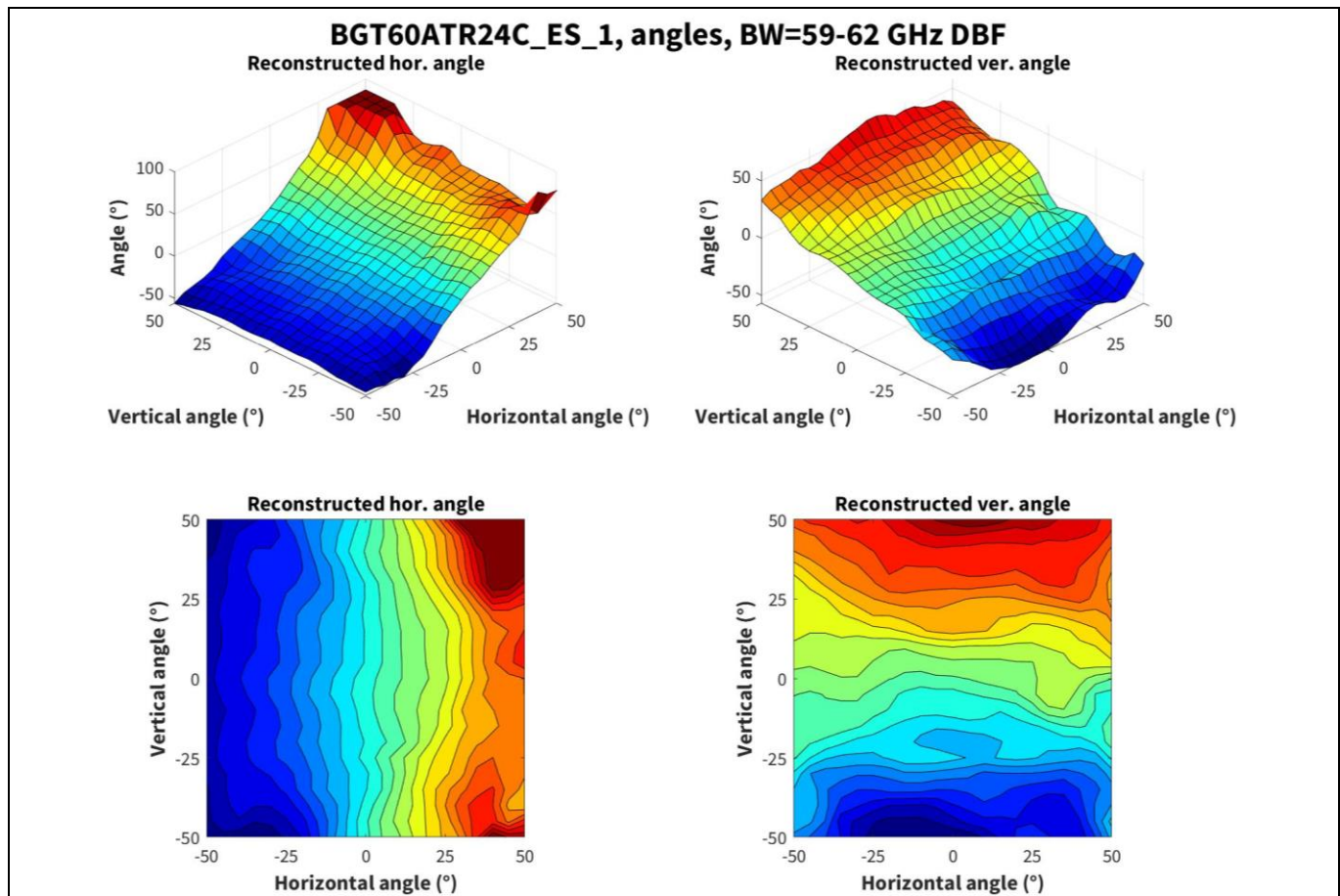

Figure 36 Reconstructed horizontal and vertical angles for 59 to 62 GHz measurements

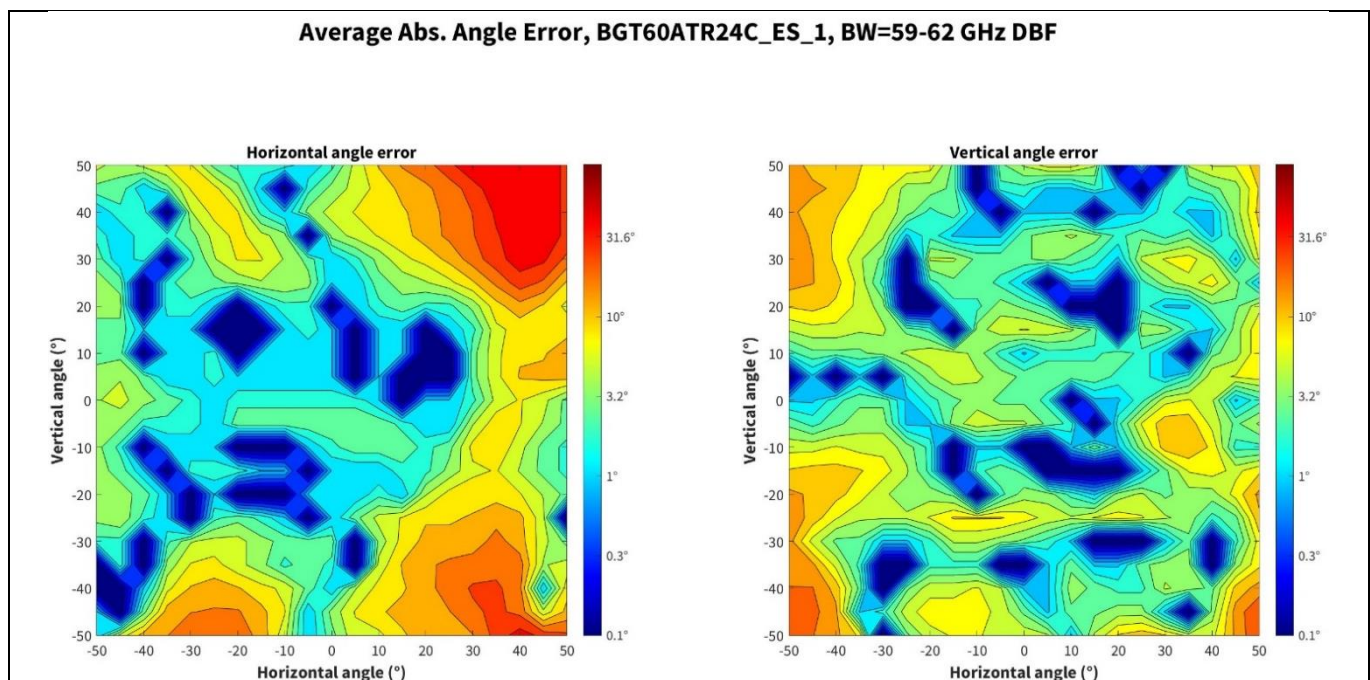

Figure 37 Angle reconstruction errors for 59 to 62 GHz measurements

BGT60ATR24C ES shield characterization

XENSIV™ 60 GHz radar system platform

4 Angle estimation

4.2.4 58 to 62 GHz

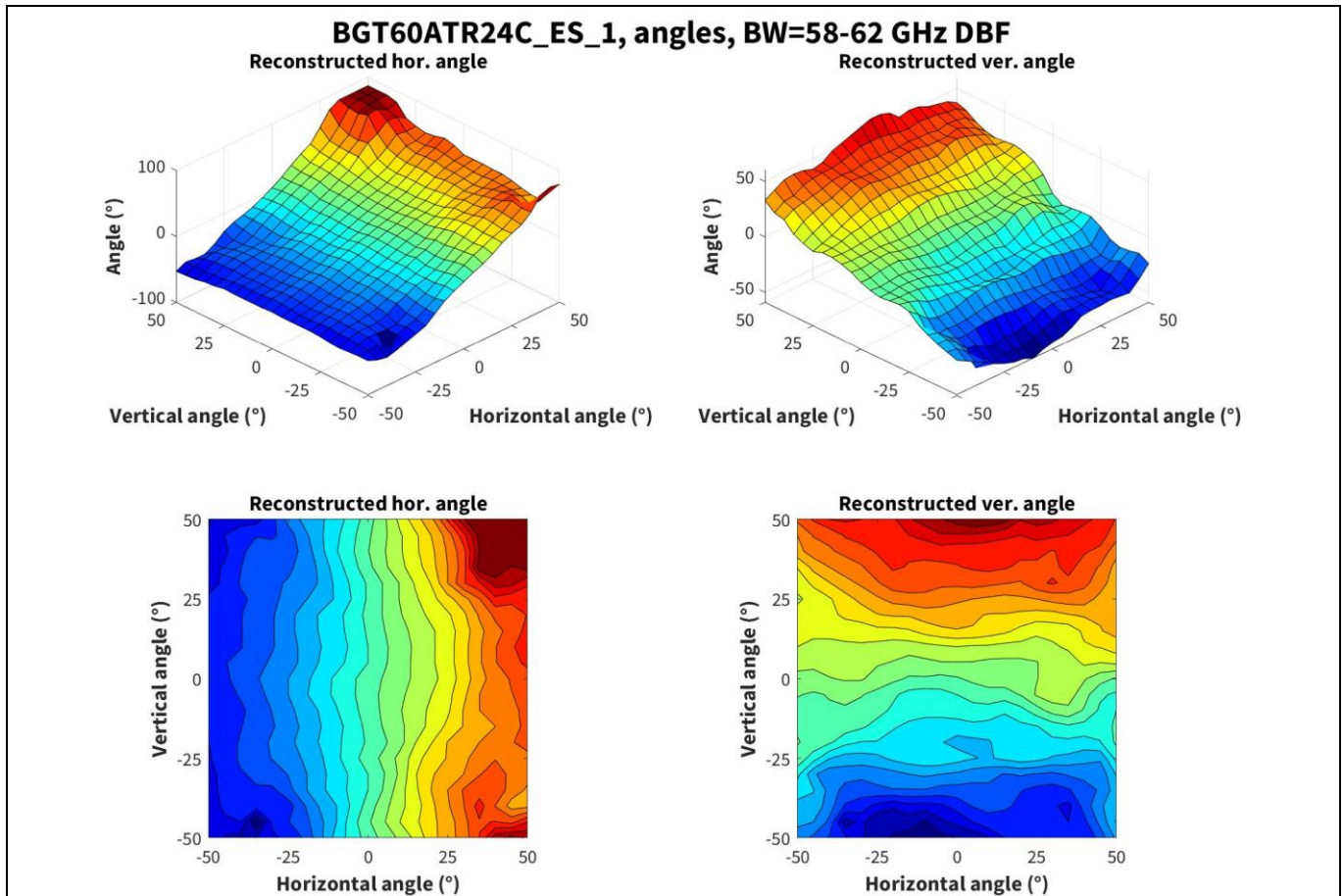

Figure 38 Reconstructed horizontal and vertical angles for 58 to 62 GHz measurements

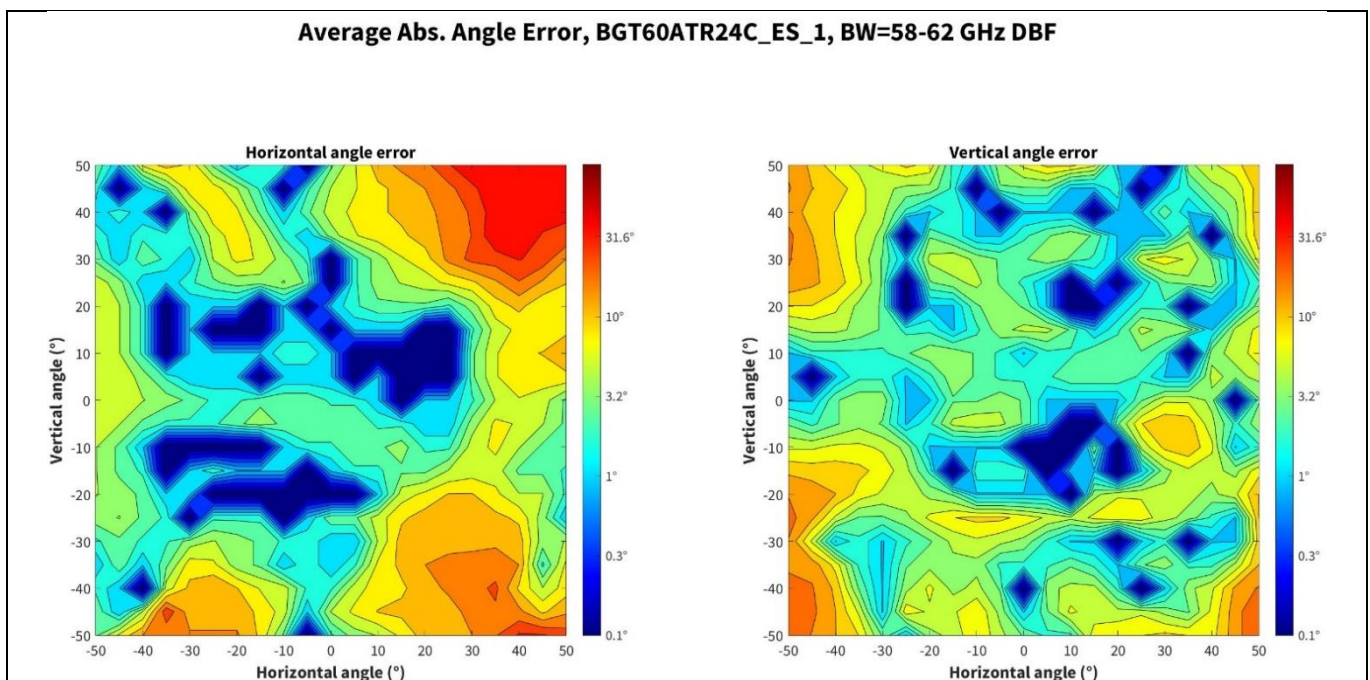

Figure 39 Angle reconstruction errors for 58 to 62 GHz measurements

BGT60ATR24C ES shield characterization

XENSIV™ 60 GHz radar system platform

4 Angle estimation

4.3 Statistical analysis

This section presents a statistical analysis of angle reconstruction errors for different frequency bands and boards. From Table 2 to Table 7, they show the mean of angle errors and the standard deviation of the errors in a certain angle span.

4.3.1 Angle span: ±30 degrees horizontal/vertical

Table 2 Mean angle errors of all frequencies and boards for angle span of ±30 degrees horizontal/vertical

| Mean error | ES_1 | | ES_2 | | ES_3 | | ES_4 | | ES_5 | | ES_6 | | ES_7 | | ES_8 | | ES_9 | | ES_10 | |
|------------------|-------|-------|-------|-------|-------|-------|-------|-------|-------|-------|-------|-------|-------|-------|-------|-------|-------|-------|-------|-------|
| | H (°) | V (°) | H (°) | V (°) | H (°) | V (°) | H (°) | V (°) | H (°) | V (°) | H (°) | V (°) | H (°) | V (°) | H (°) | V (°) | H (°) | V (°) | H (°) | V (°) |
| 58 to 62 GHz | 2.94 | 3.01 | 3.00 | 3.64 | 3.00 | 5.10 | 2.84 | 3.34 | 2.98 | 4.01 | 2.34 | 3.08 | 2.60 | 2.85 | 2.44 | 3.01 | 2.57 | 3.17 | 3.46 | 3.41 |
| 58 to 61 GHz | 2.72 | 3.09 | 2.79 | 3.34 | 2.64 | 4.46 | 2.57 | 3.04 | 2.56 | 3.51 | 2.20 | 2.86 | 2.40 | 2.77 | 2.32 | 2.79 | 2.38 | 2.95 | 2.93 | 3.10 |
| 58.5 to 61.5 GHz | 2.79 | 3.04 | 2.90 | 3.70 | 2.88 | 4.95 | 2.79 | 3.20 | 2.80 | 3.86 | 2.35 | 3.24 | 2.54 | 2.94 | 2.43 | 3.08 | 2.42 | 3.14 | 3.23 | 3.20 |
| 59 to 62 GHz | 2.85 | 3.05 | 3.07 | 4.09 | 3.07 | 5.43 | 2.92 | 3.39 | 2.96 | 4.20 | 2.47 | 3.74 | 2.88 | 3.38 | 2.62 | 3.54 | 2.57 | 3.41 | 3.57 | 3.30 |

Table 3 Standard deviation of angle errors of all frequencies and boards for angle span of ±30 degrees horizontal/vertical

| Std. dev. | ES_1 | | ES_2 | | ES_3 | | ES_4 | | ES_5 | | ES_6 | | ES_7 | | ES_8 | | ES_9 | | ES_10 | |
|------------------|-------|-------|-------|-------|-------|-------|-------|-------|-------|-------|-------|-------|-------|-------|-------|-------|-------|-------|-------|-------|
| | H (°) | V (°) | H (°) | V (°) | H (°) | V (°) | H (°) | V (°) | H (°) | V (°) | H (°) | V (°) | H (°) | V (°) | H (°) | V (°) | H (°) | V (°) | H (°) | V (°) |
| 58 to 62 GHz | 3.81 | 2.39 | 3.56 | 2.25 | 3.20 | 3.04 | 3.00 | 2.06 | 3.37 | 2.50 | 2.50 | 2.15 | 2.35 | 2.01 | 2.43 | 2.07 | 2.32 | 2.05 | 2.75 | 2.06 |
| 58 to 61 GHz | 3.20 | 2.40 | 3.07 | 2.18 | 2.69 | 2.79 | 2.83 | 2.02 | 2.86 | 2.28 | 2.43 | 1.96 | 2.29 | 1.99 | 2.36 | 1.92 | 2.09 | 1.96 | 2.35 | 1.95 |
| 58.5 to 61.5 GHz | 3.37 | 2.31 | 3.15 | 2.36 | 2.91 | 3.01 | 2.98 | 2.07 | 3.06 | 2.44 | 2.49 | 2.31 | 2.37 | 2.16 | 2.45 | 2.14 | 2.28 | 2.10 | 2.46 | 1.95 |
| 59 to 62 GHz | 3.32 | 2.45 | 3.17 | 2.62 | 3.13 | 3.17 | 2.99 | 2.30 | 3.22 | 2.56 | 2.52 | 2.53 | 2.41 | 2.32 | 2.55 | 2.48 | 2.37 | 2.37 | 2.58 | 2.05 |

4.3.2 Angle span: ±40 degrees horizontal/vertical

Table 4 Mean angle errors of all frequencies and boards for angle span of ±40 degrees horizontal/vertical

| Mean error | ES_1 | | ES_2 | | ES_3 | | ES_4 | | ES_5 | | ES_6 | | ES_7 | | ES_8 | | ES_9 | | ES_10 | |
|------------------|-------|-------|-------|-------|-------|-------|-------|-------|-------|-------|-------|-------|-------|-------|-------|-------|-------|-------|-------|-------|
| | H (°) | V (°) | H (°) | V (°) | H (°) | V (°) | H (°) | V (°) | H (°) | V (°) | H (°) | V (°) | H (°) | V (°) | H (°) | V (°) | H (°) | V (°) | H (°) | V (°) |
| 58 to 62 GHz | 5.45 | 3.30 | 5.42 | 4.07 | 5.38 | 5.55 | 4.80 | 3.60 | 5.53 | 4.38 | 4.54 | 3.63 | 4.52 | 3.38 | 4.40 | 3.61 | 4.32 | 3.65 | 5.37 | 3.62 |
| 58 to 61 GHz | 4.94 | 3.34 | 4.86 | 3.73 | 4.49 | 4.79 | 4.34 | 3.39 | 4.63 | 3.78 | 4.06 | 3.30 | 3.97 | 3.27 | 3.83 | 3.30 | 3.83 | 3.45 | 4.47 | 3.39 |
| 58.5 to 61.5 GHz | 5.32 | 3.35 | 5.36 | 4.08 | 5.15 | 5.30 | 4.80 | 3.50 | 5.34 | 4.20 | 4.44 | 3.60 | 4.30 | 3.32 | 4.30 | 3.55 | 4.15 | 3.48 | 5.16 | 3.42 |
| 59 to 62 GHz | 5.67 | 3.41 | 5.88 | 4.47 | 5.83 | 5.85 | 5.20 | 3.72 | 6.11 | 4.63 | 4.83 | 4.03 | 4.85 | 3.73 | 4.76 | 3.95 | 4.54 | 3.75 | 5.78 | 3.61 |

BGT60ATR24C ES shield characterization

XENSIV™ 60 GHz radar system platform

4 Angle estimation

Table 5 Standard deviation of angle errors of all frequencies and boards for angle span of ±40 degrees horizontal/vertical

| Std. dev. | ES_1 | | ES_2 | | ES_3 | | ES_4 | | ES_5 | | ES_6 | | ES_7 | | ES_8 | | ES_9 | | ES_10 | |
|------------------|-------|-------|-------|-------|-------|-------|-------|-------|-------|-------|-------|-------|-------|-------|-------|-------|-------|-------|-------|-------|
| | H (°) | V (°) | H (°) | V (°) | H (°) | V (°) | H (°) | V (°) | H (°) | V (°) | H (°) | V (°) | H (°) | V (°) | H (°) | V (°) | H (°) | V (°) | H (°) | V (°) |
| 58 to 62 GHz | 7.61 | 2.66 | 7.19 | 3.00 | 7.25 | 3.67 | 5.42 | 2.68 | 7.35 | 3.09 | 6.02 | 3.04 | 5.35 | 2.90 | 5.38 | 2.96 | 5.07 | 2.92 | 5.91 | 2.66 |
| 58 to 61 GHz | 6.60 | 2.70 | 5.90 | 2.79 | 5.39 | 3.35 | 5.04 | 2.59 | 5.70 | 2.76 | 5.02 | 2.61 | 4.51 | 2.67 | 4.39 | 2.63 | 4.18 | 2.68 | 4.87 | 2.39 |
| 58.5 to 61.5 GHz | 7.28 | 2.63 | 6.95 | 3.00 | 6.51 | 3.54 | 5.48 | 2.60 | 6.93 | 3.09 | 5.53 | 2.92 | 4.84 | 2.83 | 5.01 | 2.86 | 4.71 | 2.79 | 5.64 | 2.52 |
| 59 to 62 GHz | 7.86 | 2.77 | 8.05 | 3.27 | 7.82 | 3.76 | 5.88 | 2.87 | 8.59 | 3.31 | 6.21 | 3.27 | 5.26 | 3.09 | 5.54 | 3.19 | 5.22 | 3.05 | 6.36 | 2.56 |

4.3.3 Angle span: ±50 degrees horizontal/vertical

Table 6 Mean angle errors of all frequencies and boards for angle span of ±50 degrees horizontal/vertical

| Mean error | ES_1 | | ES_2 | | ES_3 | | ES_4 | | ES_5 | | ES_6 | | ES_7 | | ES_8 | | ES_9 | | ES_10 | |
|------------------|-------|-------|-------|-------|-------|-------|-------|-------|-------|-------|-------|-------|-------|-------|-------|-------|-------|-------|-------|-------|
| | H (°) | V (°) | H (°) | V (°) | H (°) | V (°) | H (°) | V (°) | H (°) | V (°) | H (°) | V (°) | H (°) | V (°) | H (°) | V (°) | H (°) | V (°) | H (°) | V (°) |
| 58 to 62 GHz | 7.46 | 4.83 | 7.39 | 5.52 | 7.32 | 6.68 | 6.91 | 5.02 | 7.51 | 5.68 | 6.42 | 5.17 | 6.11 | 5.09 | 6.02 | 5.17 | 5.70 | 5.19 | 6.95 | 4.95 |
| 58 to 61 GHz | 6.83 | 4.86 | 6.71 | 5.22 | 6.32 | 6.05 | 6.27 | 4.83 | 6.54 | 5.16 | 6.00 | 5.00 | 5.57 | 5.08 | 5.37 | 4.99 | 5.27 | 5.14 | 6.02 | 4.75 |
| 58.5 to 61.5 GHz | 7.33 | 4.83 | 7.40 | 5.56 | 7.10 | 6.48 | 6.88 | 4.93 | 7.31 | 5.54 | 6.43 | 5.14 | 6.02 | 5.05 | 5.98 | 5.11 | 5.68 | 5.06 | 6.77 | 4.77 |
| 59 to 62 GHz | 7.80 | 4.88 | 8.18 | 5.92 | 7.98 | 7.01 | 7.45 | 5.10 | 8.31 | 5.95 | 6.93 | 5.44 | 6.69 | 5.29 | 6.66 | 5.39 | 6.21 | 5.20 | 7.62 | 4.93 |

Table 7 Standard deviation of angle errors of all frequencies and boards for angle span of ±50 degrees horizontal/vertical

| Std. dev. | ES_1 | | ES_2 | | ES_3 | | ES_4 | | ES_5 | | ES_6 | | ES_7 | | ES_8 | | ES_9 | | ES_10 | |
|------------------|-------|-------|-------|-------|-------|-------|-------|-------|-------|-------|-------|-------|-------|-------|-------|-------|-------|-------|-------|-------|
| | H (°) | V (°) | H (°) | V (°) | H (°) | V (°) | H (°) | V (°) | H (°) | V (°) | H (°) | V (°) | H (°) | V (°) | H (°) | V (°) | H (°) | V (°) | H (°) | V (°) |
| 58 to 62 GHz | 9.82 | 4.69 | 9.54 | 4.70 | 9.73 | 5.02 | 8.83 | 4.42 | 9.63 | 4.59 | 8.65 | 4.96 | 7.74 | 5.15 | 7.49 | 4.93 | 7.04 | 5.05 | 8.40 | 4.47 |
| 58 to 61 GHz | 8.81 | 4.67 | 8.18 | 4.51 | 8.00 | 4.66 | 7.86 | 4.24 | 8.11 | 4.28 | 7.85 | 5.01 | 6.88 | 5.18 | 6.55 | 4.98 | 6.20 | 5.19 | 7.40 | 4.26 |
| 58.5 to 61.5 GHz | 9.57 | 4.60 | 9.56 | 4.69 | 9.16 | 4.92 | 8.58 | 4.31 | 9.22 | 4.54 | 8.74 | 4.93 | 7.66 | 5.14 | 7.48 | 4.87 | 7.18 | 4.98 | 8.27 | 4.38 |
| 59 to 62 GHz | 10.43 | 4.71 | 10.97 | 4.96 | 10.66 | 5.19 | 9.28 | 4.59 | 10.86 | 4.82 | 9.39 | 5.17 | 8.23 | 5.36 | 8.39 | 5.06 | 7.94 | 5.16 | 9.17 | 4.52 |

5 Summary and remarks

- Measurements are taken at ± 50 degrees due to the limitations in the measurement chamber.
- HPBW is calculated as 80 degrees for the horizontal plane (H-plane) and 100 degrees for the vertical plane (E-plane).
- Angles are reconstructed by a conventional 2D beamforming algorithm.
- Errors for reconstructed angles are stable for different boards and frequency bands.
- For ± 50 degrees horizontal or vertical span, the absolute average angle error is about 7 degrees for horizontal angles and 5 degrees for vertical angles.

References

- [1] Infineon Technologies AG. [AN620: BGT60ATR24C ES shield](#)
- [2] Infineon Technologies AG. [AN599: Radar Baseboard MCU7](#)
- [3] Committee, E. C. (n.d.). ERC Recommendation. Retrieved 14 02, 2023, from <https://docdb.cept.org/download/4298>
- [4] European Telecommunications Standards Institute. (n.d.). Retrieved 03 12, 2019, from <https://www.etsi.org/>
- [5] Federal Communications Commission. (n.d.). Retrieved 03 12, 2019, from <https://www.fcc.gov/>
- [6] Institute, E. T. (n.d.). EN 305 500. Retrieved 03 12, 2019, from https://www.etsi.org/deliver/etsi_en/305500_305599/305550/02.01.00_20/en_305550v020100a.pdf
- [7] Regulations, E. C. (n.d.). §15.255. Retrieved 03 12, 2019, from https://www.ecfr.gov/cgi-bin/text-idx?SID=a484297320706bbafb187c022e7b3c0c&mc=true&node=se47.1.15_1255&rgn=div8

Revision history

Revision history

| Document revision | Date | Description of changes |
|--------------------------|-------------|--|
| 1.00 | 2021-09-17 | Initial version |
| 1.10 | 2022-08-26 | Updated figures |
| 1.20 | 2023-06-06 | Miscellaneous document cleanup updates |

Trademarks

All referenced product or service names and trademarks are the property of their respective owners.

Edition 2023-06-06

Published by

Infineon Technologies AG

81726 Munich, Germany

**© 2023 Infineon Technologies AG.
All Rights Reserved.**

Do you have a question about this document?

Email: erratum@infineon.com

Document reference

AN_2109_PL32_2110_131711

Important notice

The information contained in this application note is given as a hint for the implementation of the product only and shall in no event be regarded as a description or warranty of a certain functionality, condition or quality of the product. Before implementation of the product, the recipient of this application note must verify any function and other technical information given herein in the real application. Infineon Technologies hereby disclaims any and all warranties and liabilities of any kind (including without limitation warranties of non-infringement of intellectual property rights of any third party) with respect to any and all information given in this application note.

The data contained in this document is exclusively intended for technically trained staff. It is the responsibility of customer's technical departments to evaluate the suitability of the product for the intended application and the completeness of the product information given in this document with respect to such application.

Warnings

Due to technical requirements products may contain dangerous substances. For information on the types in question please contact your nearest Infineon Technologies office.

Except as otherwise explicitly approved by Infineon Technologies in a written document signed by authorized representatives of Infineon Technologies, Infineon Technologies' products may not be used in any applications where a failure of the product or any consequences of the use thereof can reasonably be expected to result in personal injury.