

BGA5M1BN6 as a Bypass LNA for GNSS applications from 1166 MHz to 1186 MHz

About this document

Scope and purpose

This application note describes Infineon's BGA5M1BN6 as a Low Noise Amplifier (LNA) for Global Navigation Satellite System (GNSS) applications in the frequency range of 1166 MHz to 1186 MHz.

The BGA5M1BN6 is a silicon germanium (SiGe) LNA.

1. The target applications of this circuit are GPS L5/Galileo E5/GLONASS L3/BeiDou B2/QZSS L5/NavIC L5 modules in the range of 1166 MHz to 1186 MHz.
2. In this report, the performance of BGA5M1BN6 is investigated on a FR4 board. This device is matched with 0402 size high Q-factor LQW15 inductors. Noise Figure (NF) deviation, when matched with 0201 size LQP03T inductors, is also presented.
3. Key performance parameters at 1.8 V, 1176.45 MHz:
 - High Gain Mode
 - NF = 1.0 dB (LQW15 inductors for matching)
 - NF = 1.05 dB (LQP03T inductors for matching)
 - Insertion gain = 16 dB
 - Input return loss = 14 dB
 - Output return loss = 11 dB
 - Out-of-band input IM3 = - 81 dBm (measured at 1169 MHz)

Bypass Mode

- NF = 1.0 dB (LQW15 inductors for matching)
- NF = 1.05 dB (LQP03T inductors for matching)
- Insertion gain = 16 dB
- Input return loss = 14 dB
- Output return loss = 11 dB
- Out-of-band input IM3 = - 81 dBm (measured at 1169 MHz)

Table of contents

About this document	1
Table of contents	2
List of figures¹	3
List of tables	3
1 Introduction of the Global Navigation Satellite System	4
1.1 Global Navigation Satellite System (GNSS).....	4
1.2 Lower L bands	4
1.3 Infineon product portfolio for GNSS applications	5
1.4 Key features of GNSS LNAs.....	5
1.4.1 Low NF and high gain.....	5
1.4.2 High robustness against coexistence of out-of-band jammer signals.....	6
1.4.3 Low current consumption	6
2 BGA5M1BN6 overview	7
2.1 Features	7
2.2 Key applications of BGA5M1BN6	7
3 Application circuit and performance overview	8
3.1 Summary of measurement results	8
3.2 Schematic and BOM	10
4 Measurement graphs	11
5 Evaluation board and layout information	22
6 Authors	24
7 References	25

List of figures¹

Figure 1	Application diagram: receiver front end of the GNSS	4
	Frequency allocation of GNSS systems – upper L band and lower L band	5
Figure 2	5	
Figure 3	BGA5M1BN6 in TSNP-6-10.....	7
Figure 4	Schematic of the BGA5M1BN6 application circuit	10
Figure 5	Insertion power gain (narrowband) of BGA5M1BN6 for GNSS applications.....	11
Figure 6	Insertion power gain (wideband) of BGA5M1BN6 for GNSS applications.....	12
Figure 7	NF of BGA5M1BN6 for GNSS applications (SMA and connector losses de-embedded, LQW15 inductors for matching)	13
Figure 8	NF of BGA5M1BN6 for GNSS applications (SMA and connector losses de-embedded, LQP03T inductors for matching)	13
Figure 9	Input return loss of BGA5M1BN6 for GNSS applications	14
Figure 10	Output return loss of BGA5M1BN6 for GNSS applications.....	15
Figure 11	Reverse isolation of BGA5M1BN6 for GNSS applications.....	16
Figure 12	Stability K-factor of BGA5M1BN6 for GNSS applications.....	17
Figure 13	Input 1 dB compression point of BGA5M1BN6 for GNSS applications.....	18
Figure 14	Out-of-band third-order intermodulation point of BGA5M1BN6 for GNSS applications (L5 band, output referred).....	19
Figure 15	Out-of-band second-order intermodulation point of BGA5M1BN6 for GNSS applications (L5 band, output referred).....	20
Figure 16	Inband third-order intermodulation point of BGA5M1BN6 for GNSS applications (output referred)	21
Figure 17	Evaluation board (overview).....	22
Figure 18	Evaluation board (detailed view).....	22
Figure 19	PCB layer information	23

List of tables

Table 1	Electrical characteristics at 1.8 V (at room temperature)	8
Table 2	Electrical characteristics at 2.8 V (at room temperature)	9
Table 3	BOM.....	10

1) The graphs were generated with the simulation program AWR Microwave Office®.

1 Introduction of the Global Navigation Satellite System

1.1 Global Navigation Satellite System (GNSS)

The Global Navigation Satellite System (GNSS) covers the mostly commonly used services in the electronic industry. Today, the following GNSS systems are in operation: the United States GPS, the Russian GLobal Orbiting Navigation Satellite System (GLONASS), the Chinese BeiDou Navigation Satellite System (BDS), the European Union Galileo navigation system (Galileo), the Japanese Quasi-Zenith Satellite System (QZSS) and the Indian Regional Navigation Satellite System (IRNSS or NavIC). Main market segments include GNSS-enabled cell phones, Personal Navigation Devices (PNDs), GNSS-enabled portable devices and Internet-of-Things (IoT) devices.

For the GNSS-enabled cell phones, the main challenges are to achieve high sensitivity and high immunity for safety and emergency reasons against interference from cellular signals and other wireless connectivity signals. The GNSS signals must be received at very low power levels (down to less than -130 dBm) in cell phones in the vicinity of coexisting high-power cellular and other wireless connectivity signals.

The main challenges for the GNSS-enabled portable devices are to obtain a high system sensitivity for precise detection, and low Time-To-First Fix (TTFF) to quickly locate the device. Below diagram demonstrates the RF frontend structure of a GNSS-enabled portable module. The LNA is switched to high gain mode when the module does not use the external active antenna, and to bypass mode when the module switches to external active antenna.

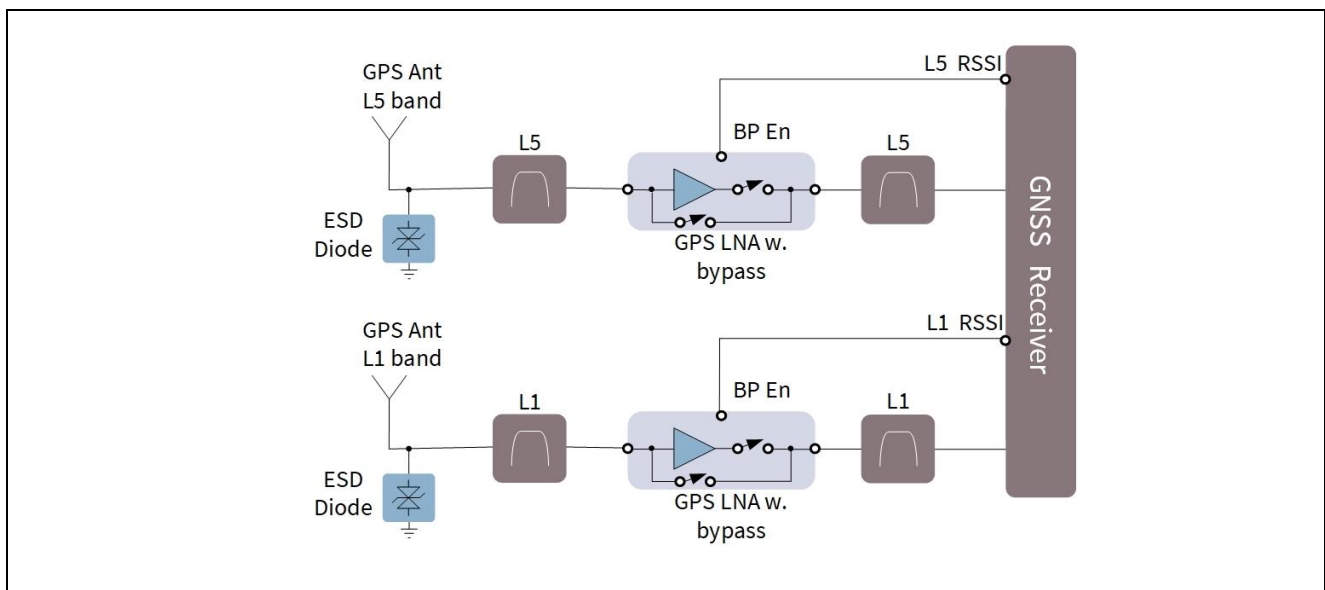

Figure 1 Application diagram: receiver front end of the GNSS

1.2 Lower L bands

The GNSS systems were first operated in the upper L band ranging from 1559 MHz to 1610 MHz. Recently, GNSS applications in the lower L bands, ranging from 1164 MHz to 1300 MHz, have started to emerge in civil use.

The lower L bands include GPS L5/GLONASS L3/BDS B2/Galileo E5/QZSS L5/NavIC L5 bands (1164 MHz to 1217 MHz), and GPS L2/GLONASS L2/BDS B3/Galileo E6/QZSS L2C/QZSS LEX bands (1217 MHz to 1300 MHz).

For example, the GPS L5 band hosts a civilian safety-of-life signal, and is intended to provide a means of radio navigation secure and robust enough for life-critical applications, such as aircraft precision approach guidance. The GPS L2 band has been used for high-precision location navigation.

Figure 2 illustrates an overview of the frequency allocation of GNSS applications.

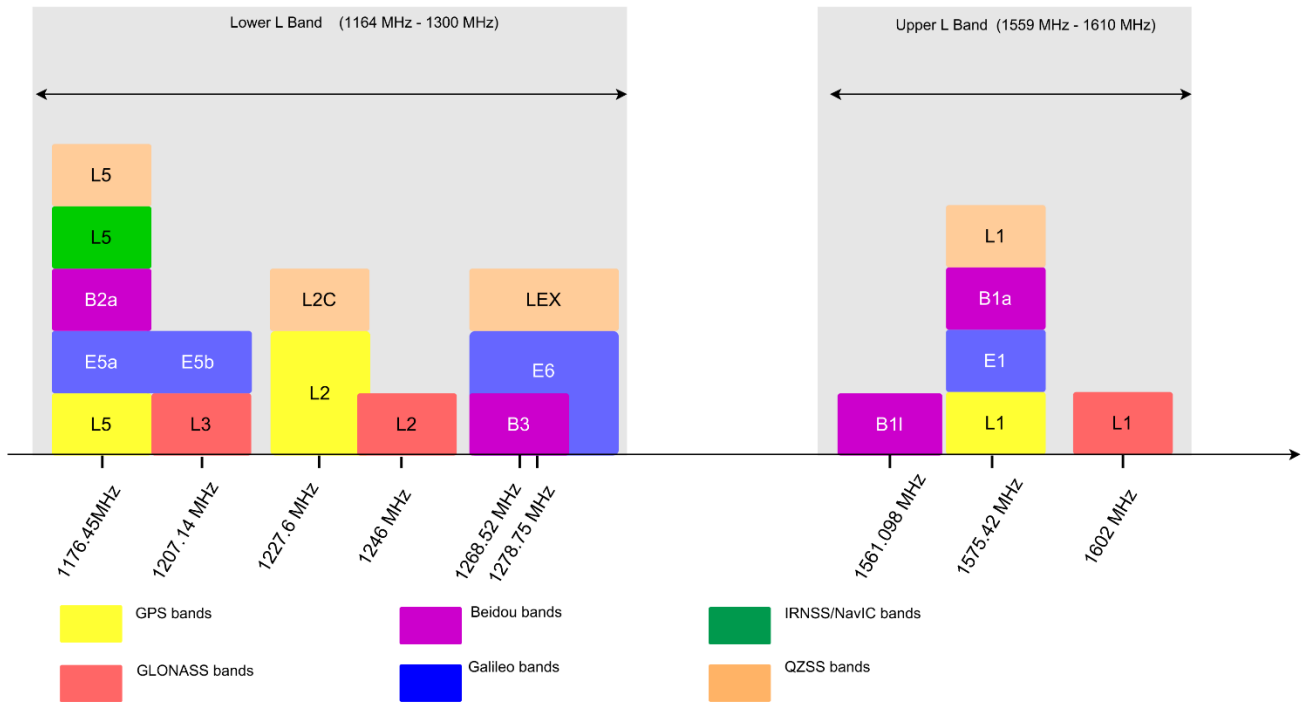

Figure 2 Frequency allocation of GNSS systems – upper L band and lower L band

1.3 Infineon product portfolio for GNSS applications

Infineon Technologies offers the following product portfolio to all customers designing high-performance flexible RF front-end solutions for all GNSS systems:

- **LNAs:** Infineon offers a wide range of products such as high-performance Monolithic Microwave Integrated Circuits (MMICs) as well as cost-effective and high-end RF transistors
- **Transient Voltage Suppression (TVS) diodes:** Infineon devices can protect GNSS antennas reliably up to 20 kV

1.4 Key features of GNSS LNAs

Infineon is among the leading suppliers for GNSS LNAs for navigation applications. The GNSS MMIC LNAs are designed with the following features.

1.4.1 Low NF and high gain

The power levels of satellite signals received by a GNSS receiver are as low as -130 dBm. An external LNA with exceptionally low NF and good gain helps to boost the signal-to-noise ratio of the system. The existing LNA portfolio includes devices with various gain levels that can be tailored to customers’ RF systems.

1.4.2 High robustness against coexistence of out-of-band jammer signals

In the presence of very weak GNSS satellite signals, there is no inband interference signal in the GNSS receiver front ends.

In the case of cell phone systems, GNSS signals coexist with strong jammer signals from other RF applications, e.g. 3G/4G, wireless LAN, etc. The above out-of-band jammer signals can mix to produce intermodulation products in the GNSS receiver frequency band. Compared with the received signal level from GNSS satellites, the resulting intermodulation products are significant interference, therefore LNAs with high robustness against out-of-band interference signals are required.

1.4.3 Low current consumption

Power consumption is an important feature in many GNSS systems that are mainly battery-operated mobile devices. Infineon's LNAs have an integrated power-on/-off feature that provides for low power consumption and increased stand-by time for GNSS handsets. Moreover, the recent development has focused on low current (e.g. 1.1 mA) and low supply voltage (1.2 V), making the LNAs suitable for portable devices such as GNSS-enabled wearables and connected IoT devices.

Please visit www.infineon.com for more details on LNA products for navigation in cell phones and portable devices.

2 BGA5M1BN6 overview

2.1 Features

- Operating frequencies: 1805 MHz to 2200 MHz
- Insertion power gain: 19.3 dB
- Insertion loss in bypass mode: 4.7 dB
- Low NF: 0.65 dB
- Low current consumption: 9.5 mA
- Multi-state control: bypass and high-gain mode
- Ultra-small TSNP-6-10 leadless package
- RF output internally matched to 50 Ω
- Low external component count

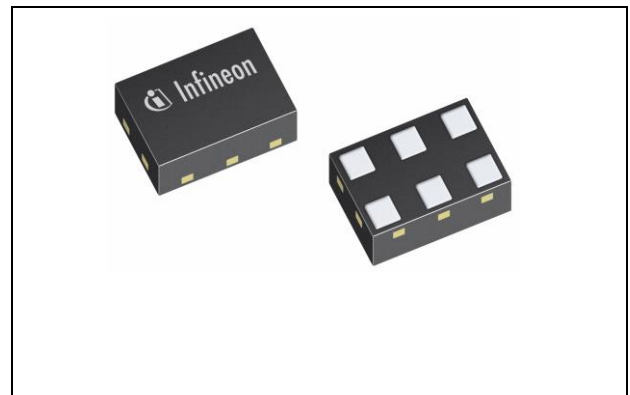

Figure 3 BGA5M1BN6 in TSNP-6-10



2.2 Key applications of BGA5M1BN6

BGA5M1BN6 is designed to enhance receiving sensitivity in LTE applications.

In this application note, it is retuned to improve the reception quality of the GNSS applications.

In high-gain mode the LNA offers the best NF to ensure high sensitivity. In bypass mode, the LNA works under reduced current consumption. The integrated bypass function increases the overall system dynamic range and leads to more flexibility in the RF front end.

Please visit the [product page](#) of BGA5M1BN6 for more information.

3 Application circuit and performance overview

In this chapter the performance of the application circuit, the schematic and Bill of Materials (BOM) are presented.

Device:	BGA5M1BN6
Application:	LNA for GNSS applications in the range 1166 MHz to 1186 MHz
PCB marking:	BGAxxxN6 V4.0
EVN order no.:	AN611

3.1 Summary of measurement results

The performance of BGA5M1BN6 for GNSS lower L band applications is summarized in the following tables.

Table 1 Electrical characteristics at 1.8 V (at room temperature)

Parameter	Symbol	Value		Unit	Comment/test condition
Frequency range	Freq	1176		MHz	L5 band center frequency
DC voltage	V _{CC}	1.8		V	
Mode	M	High gain	Bypass	--	
DC current	I _{CC}	9.2	0.085	mA	High Gain Mode, Bypass Mode
Gain	G	16.0	-4.3	dB	
Noise Figure ¹⁾	NF	1.0	4.7	dB	LQW15 inductor for matching, loss of input line of 0.10 dB is de-embedded ¹⁾
Noise Figure ²⁾	NF	1.05	4.9	dB	LQP03TN inductor for matching, loss of input line of 0.10 dB is de-embedded ²⁾
Input return loss	RL _{in}	14	8	dB	
Output return loss	RL _{out}	11	6	dB	
Reverse isolation	IRev	34	4	dB	
Input IP3	IIP3	-9	9	dBm	Power at input: -30 dBm f1 = 1176 MHz, f2 = 1177 MHz
Input P1dB	IP1dB	-19	-1	dBm	At 1176 MHz
Out-of-band input IP3 ³⁾	Oob_IIP3	5	22	dBm	Power at input: -20 dBm (high gain) -10 dBm (bypass)
Out-of-band output IM3	Oob_OIM ₃	-54	-79	dBm	f1 = 1785 MHz, f2 = 2401 MHz Oob_IM3 measured at 1169 MHz
Out-of-band input IP2 ³⁾	Oob_IIP2	28	46	dBm	Power at input: -20 dBm f1 = 2550 MHz, f2 = 3726 MHz
Out-of-band output IM2	Oob_OIM ₂	-52	-91	dBm	Oob_IM2 measured at 1176 MHz

BGA5M1BN6 as a Bypass LNA for GNSS applications from 1166 MHz to 1186 MHz



Application circuit and performance overview

Table 1 Electrical characteristics at 1.8 V (at room temperature)

Parameter	Symbol	Value	Unit	Comment/test condition
Stability	k	> 1	-	Measured up to 10 GHz

3) Out-of-band input IMx = IM level output referred – gain at the measured frequency

Table 2 Electrical characteristics at 2.8 V (at room temperature)

Parameter	Symbol	Value		Unit	Comment/test condition
Frequency range	Freq	1176		MHz	L5 band center frequency
DC voltage	V _{CC}	2.8		V	
Mode	M	High gain	Bypass	--	
DC current	I _{CC}	10.1	0.09	mA	
Gain	G	16.5	-4.7	dB	
Noise Figure ¹⁾	NF	1.0	4.65	dB	LQW15 inductor for matching, loss of input line of 0.10 dB is de-embedded ¹⁾
Noise Figure ²⁾	NF	1.05	4.9	dB	LQP03TN inductor for matching, loss of input line of 0.10 dB is deembedded ²⁾
Input return loss	RL _{in}	14	8	dB	
Output return loss	RL _{out}	11	6	dB	
Reverse isolation	I _{Rev}	35	4	dB	
Input IP3	IIP3	-9	9	dBm	Power at input: -30 dBm f1 = 1176 MHz, f2 = 1177 MHz
Input P1dB	IP1dB	-19	0	dBm	At 1176 MHz
Out-of-band input IP3 ³⁾	Oob_IIP3	2	22	dBm	Power at input: -20 dBm (high gain) -10 dBm (bypass)
Out-of-band output IM3	Oob_OIM3	-48	-79	dBm	f1 = 1785 MHz, f2 = 2401 MHz Oob_IM3 measured at 1169 MHz
Out-of-band input IP2 ³⁾	Oob_IIP2	28	46	dBm	Power at input: -20 dBm f1 = 2550 MHz, f2 = 3726 MHz
Out-of-band output IM2	Oob_OIM2	-52	-91	dBm	Oob_IM2 measured at 1176 MHz
Stability	k	> 1		-	Measured up to 10 GHz

3) Out-of-band input IMx = IM level output referred – gain at the measured frequency

BGA5M1BN6 as a Bypass LNA for GNSS applications from 1166 MHz to 1186 MHz



Application circuit and performance overview

3.2 Schematic and BOM

The schematic of BGA5M1BN6 for GNSS applications is presented in **Figure 4** and its BOM is shown in **Table 3**.

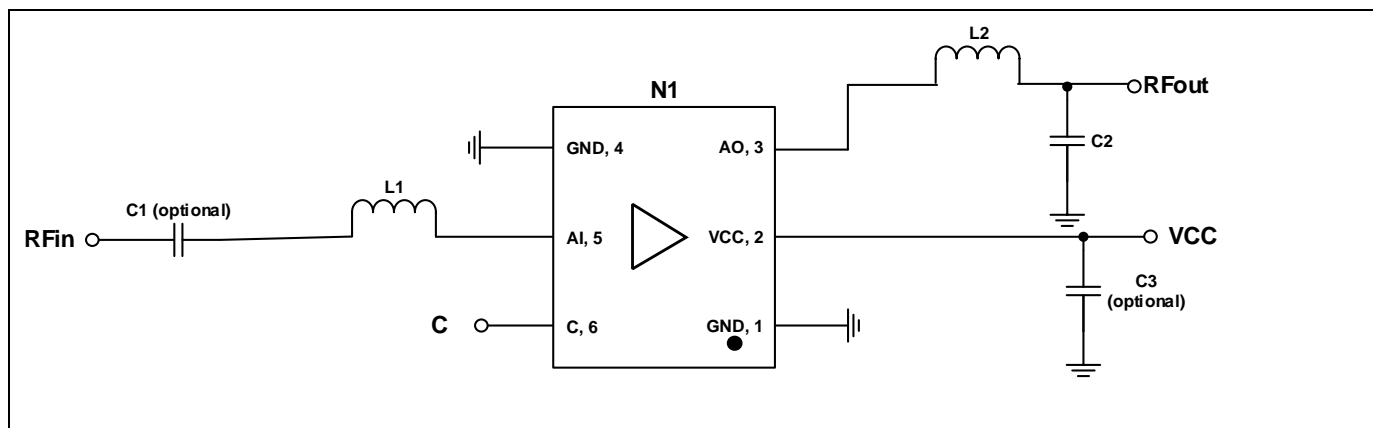

Figure 4 Schematic of the BGA5M1BN6 application circuit

Table 3 BOM

Symbol	Value	Unit	Size	Manufacturer	Comment
C1	1	nF	0402/0201	Various	DC block (optional)
C2	2.2/2.7 ¹⁾	pF	0402/0201	Various	Output matching
C3	1	nF	0402/0201	Various	RF bypass (optional)
L1	11	nH	0402/0201	Murata LQW15/LQP03T	Input matching
L2	10	nH	0402/0201	Murata LQW15/LQP03T	Output matching
N1	BGA5M1BN6	TSNP-6-2		Infineon Technologies	SiGe LNA

1) 2.2 pF is recommended when using 0402-inch components ; 2.7 pF is recommended when using 0201-inch components

Note: DC block function is NOT integrated at the input pin. DC block capacitor C1 is not necessary if the DC block function on the RF input line can be ensured by the previous stage. For reducing switching time, lower DC block cap value is recommended. C1 = 100 pF enables less than 3 μS switching time.

Note: The RF bypass capacitor C3 at the DC power supply pin filters out the power supply noise and stabilizes the DC supply. The C3 is not necessary if a clean and stable DC supply can be ensured.

4 Measurement graphs

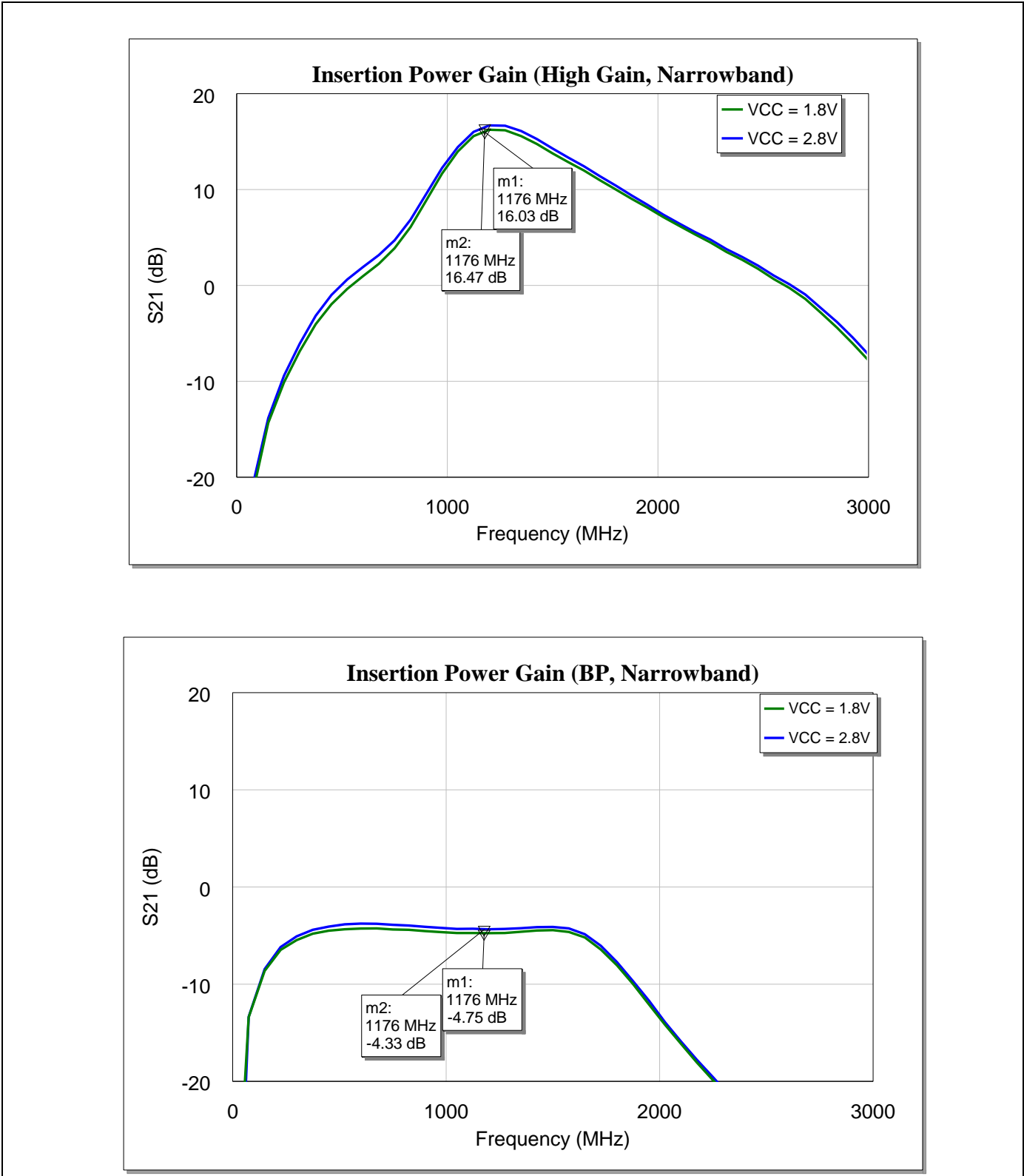

Figure 5 Insertion power gain (narrowband) of BGA5M1BN6 for GNSS applications

Measurement graphs

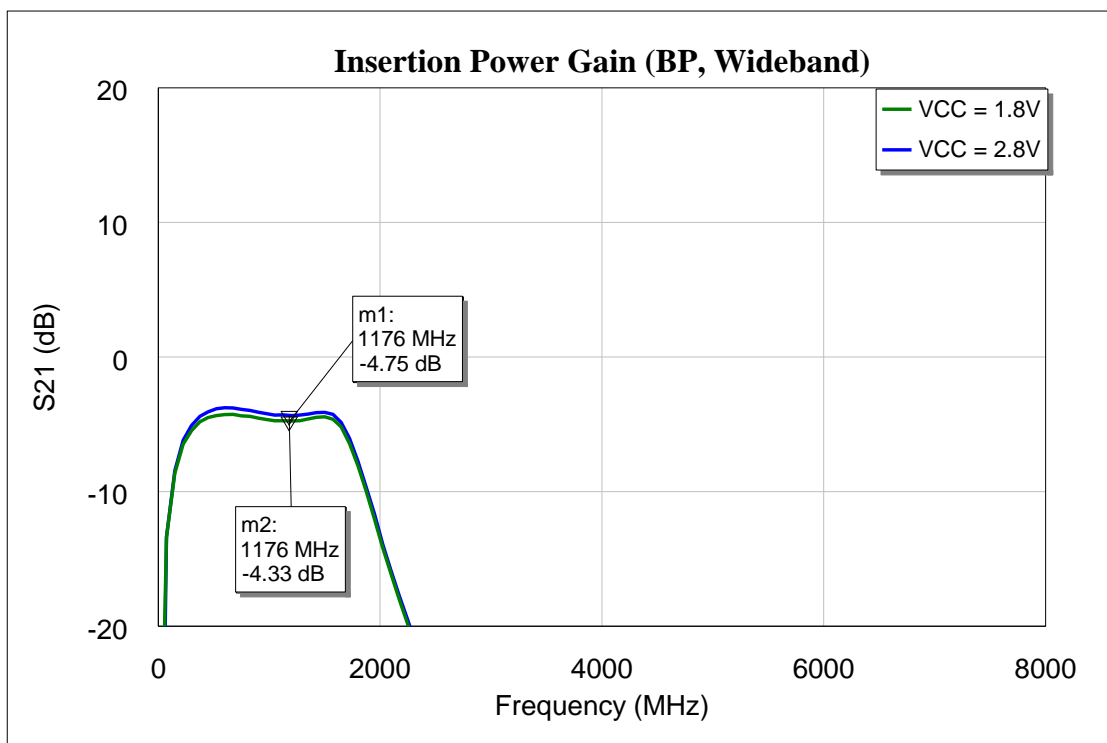
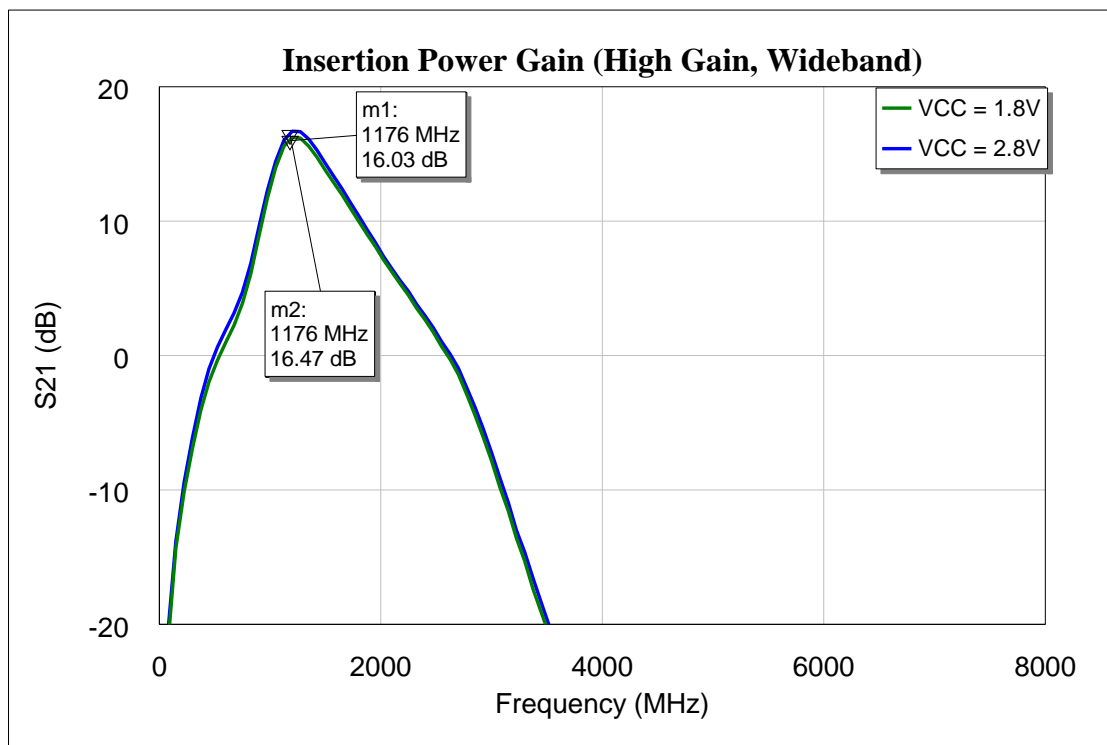

Figure 6 Insertion power gain (wideband) of BGA5M1BN6 for GNSS applications

BGA5M1BN6 as a Bypass LNA for GNSS applications from 1166 MHz to 1186 MHz



Measurement graphs

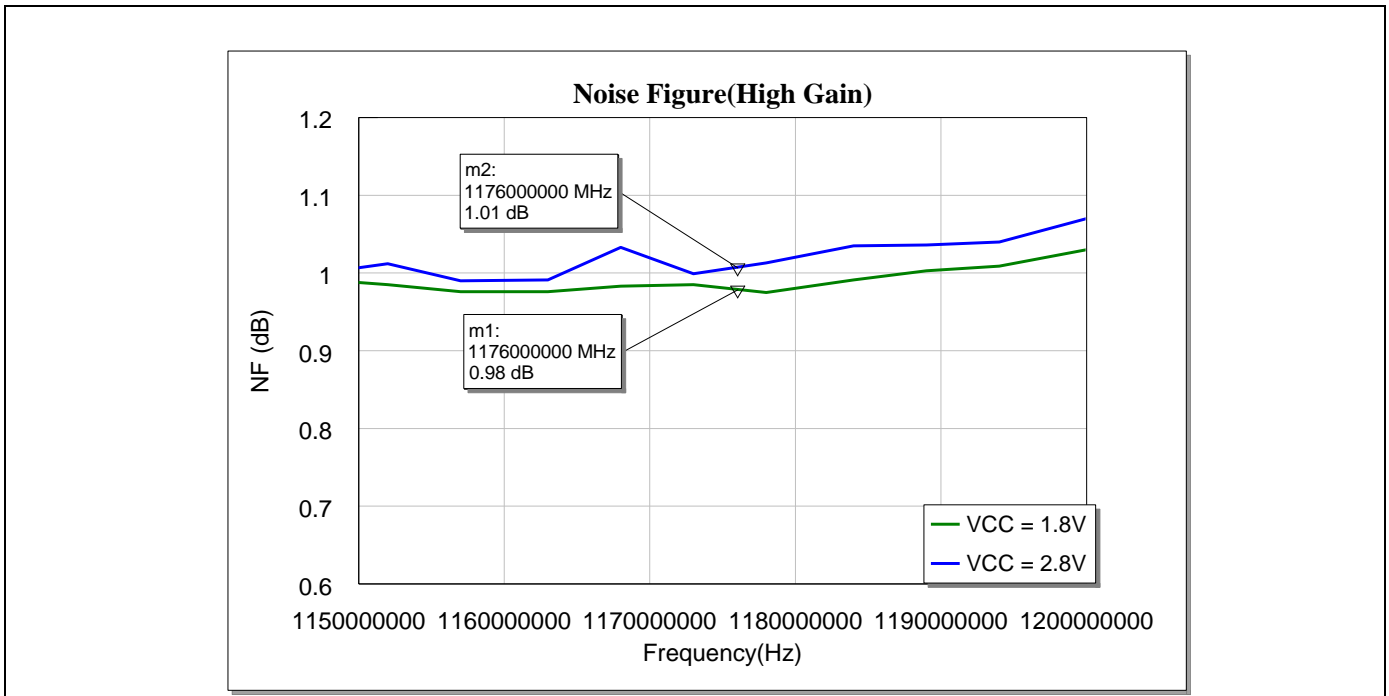

Figure 7 NF of BGA5M1BN6 for GNSS applications (SMA and connector losses de-embedded, LQW15 inductors for matching)

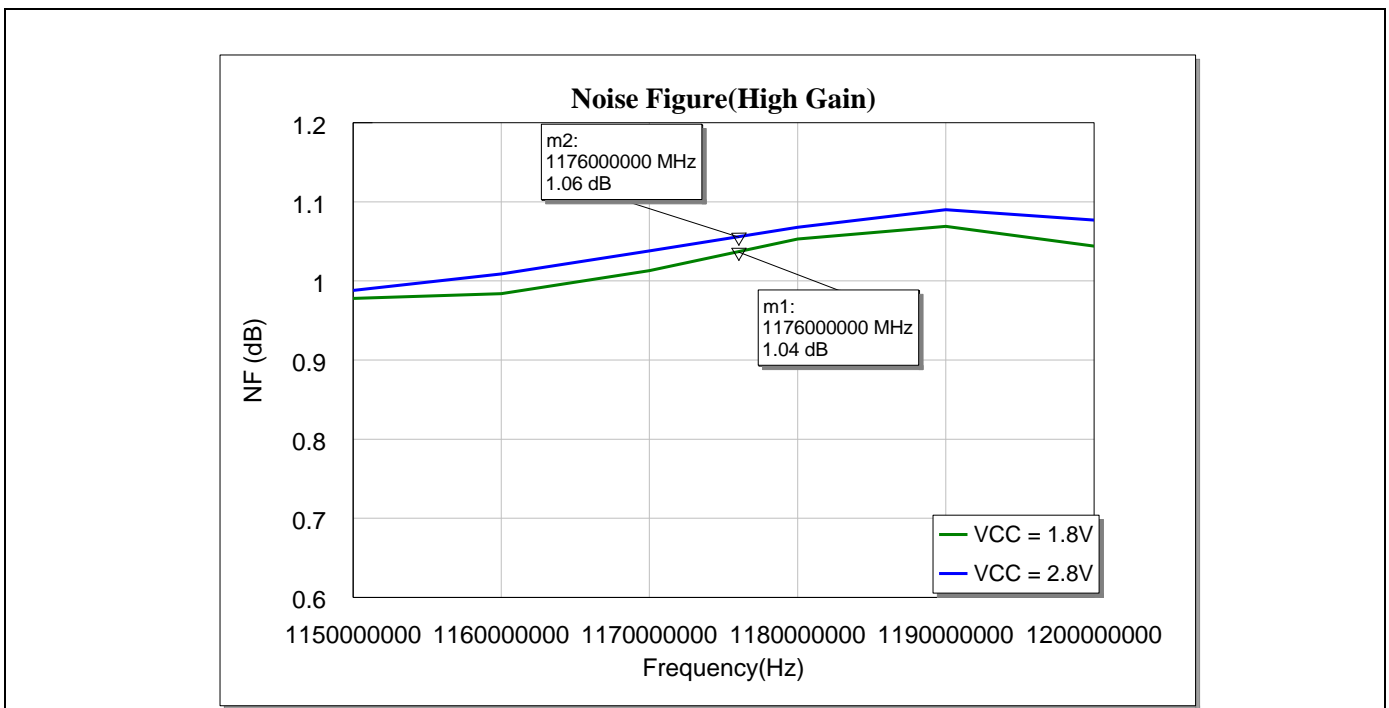

Figure 8 NF of BGA5M1BN6 for GNSS applications (SMA and connector losses de-embedded, LQP03T inductors for matching)

BGA5M1BN6 as a Bypass LNA for GNSS applications from 1166 MHz to 1186 MHz



Measurement graphs

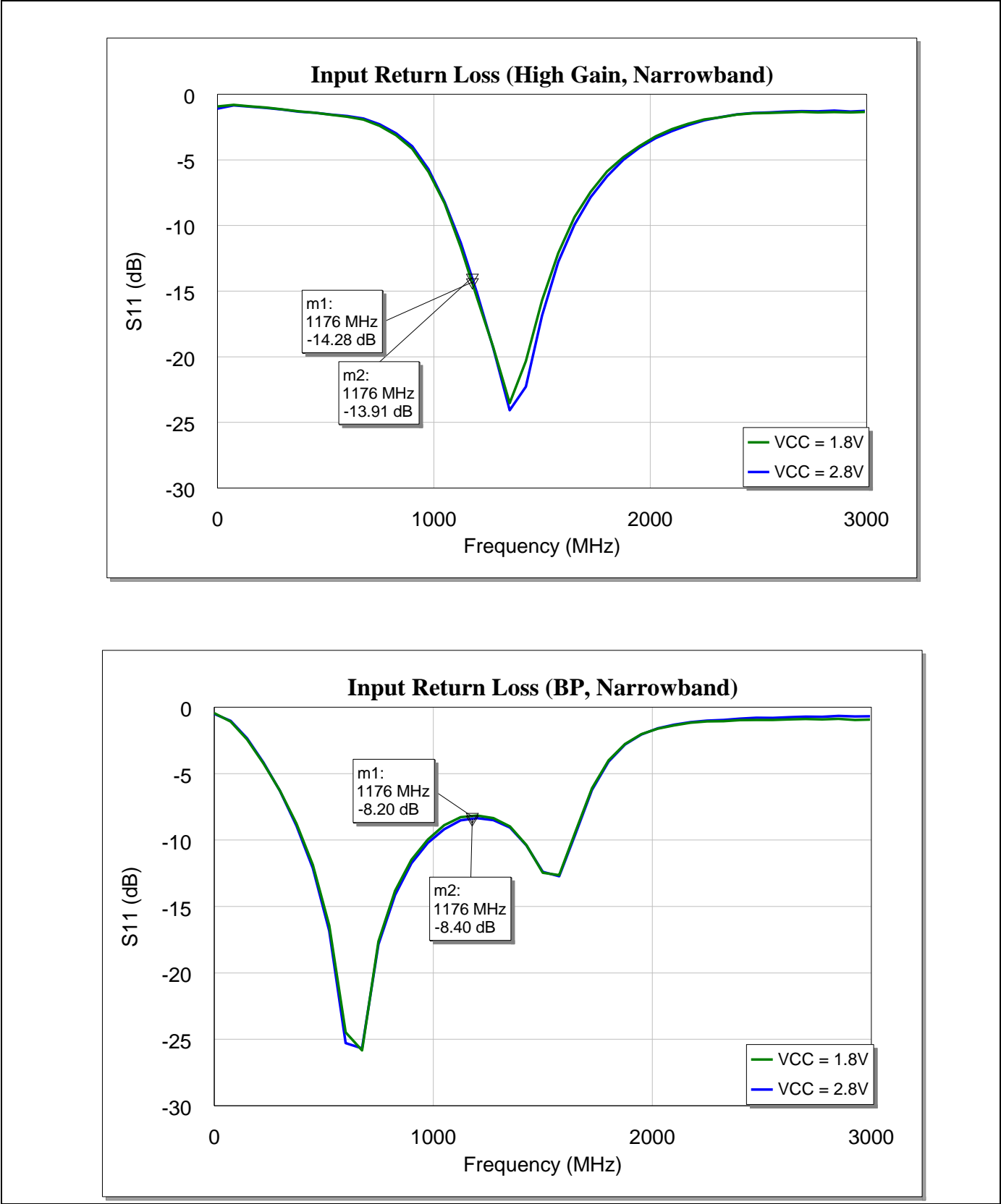

Figure 9 Input return loss of BGA5M1BN6 for GNSS applications

Measurement graphs

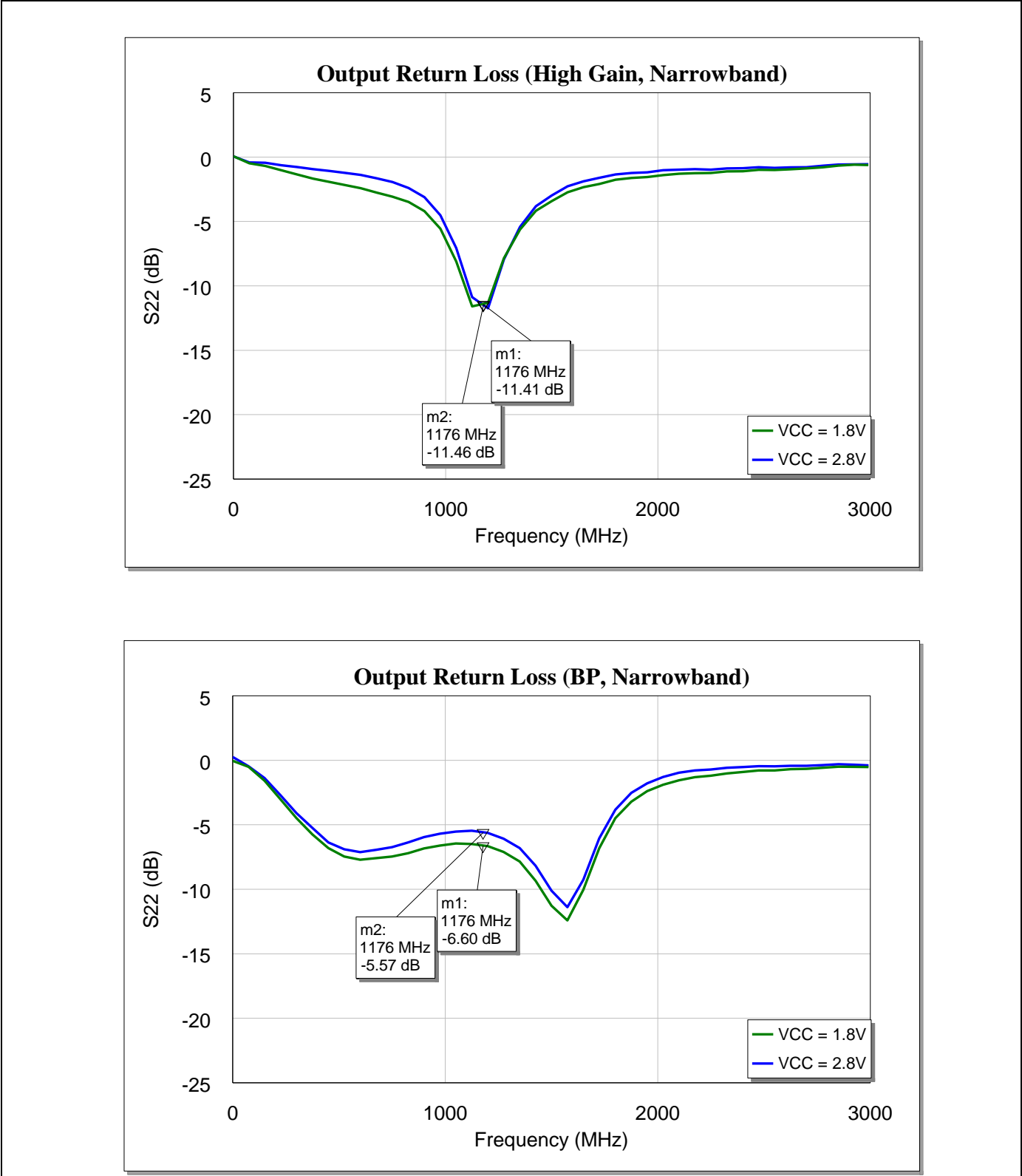

Figure 10 Output return loss of BGA5M1BN6 for GNSS applications

BGA5M1BN6 as a Bypass LNA for GNSS applications from 1166 MHz to 1186 MHz



Measurement graphs

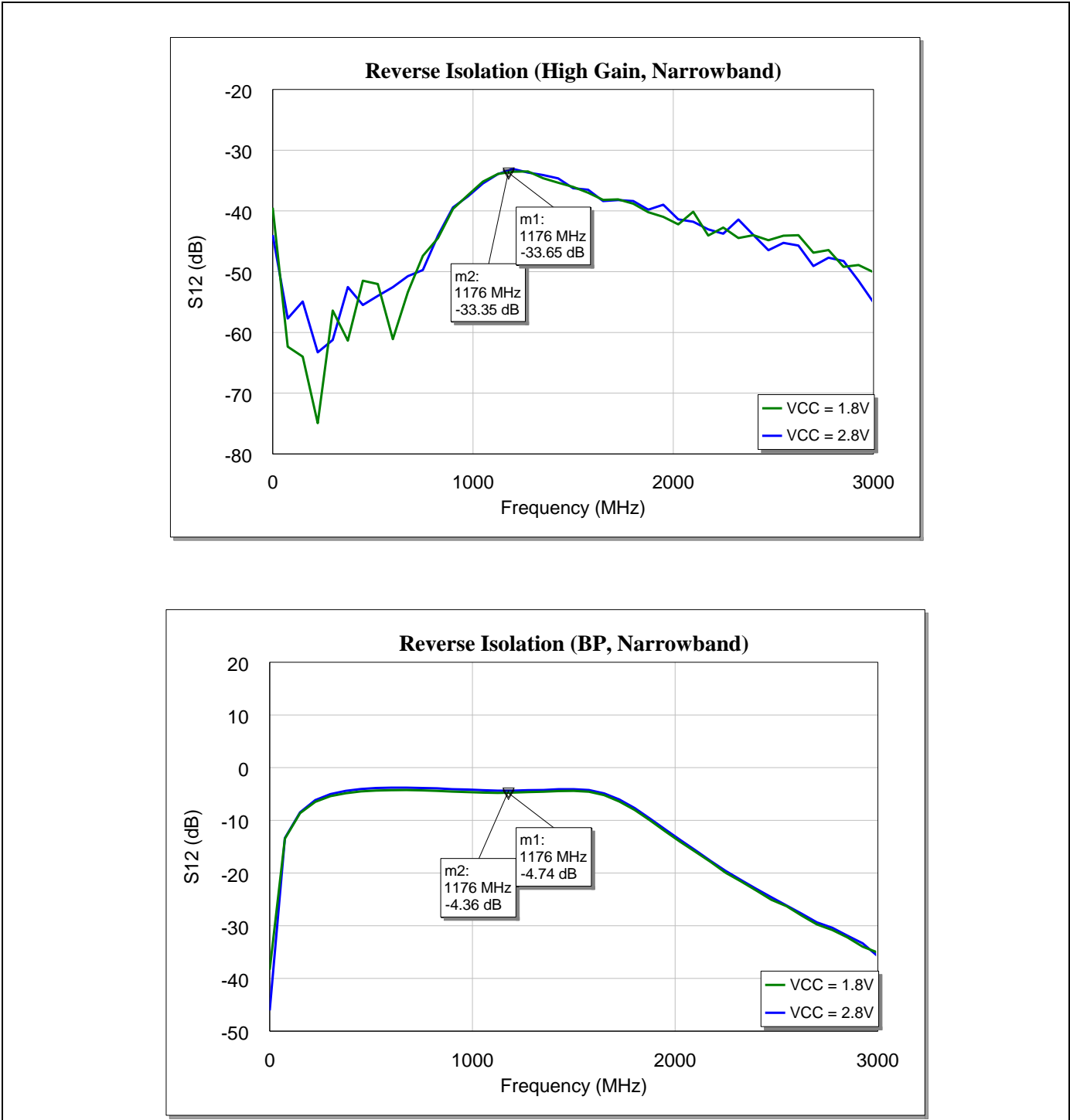

Figure 11 Reverse isolation of BGA5M1BN6 for GNSS applications

BGA5M1BN6 as a Bypass LNA for GNSS applications from 1166 MHz to 1186 MHz



Measurement graphs

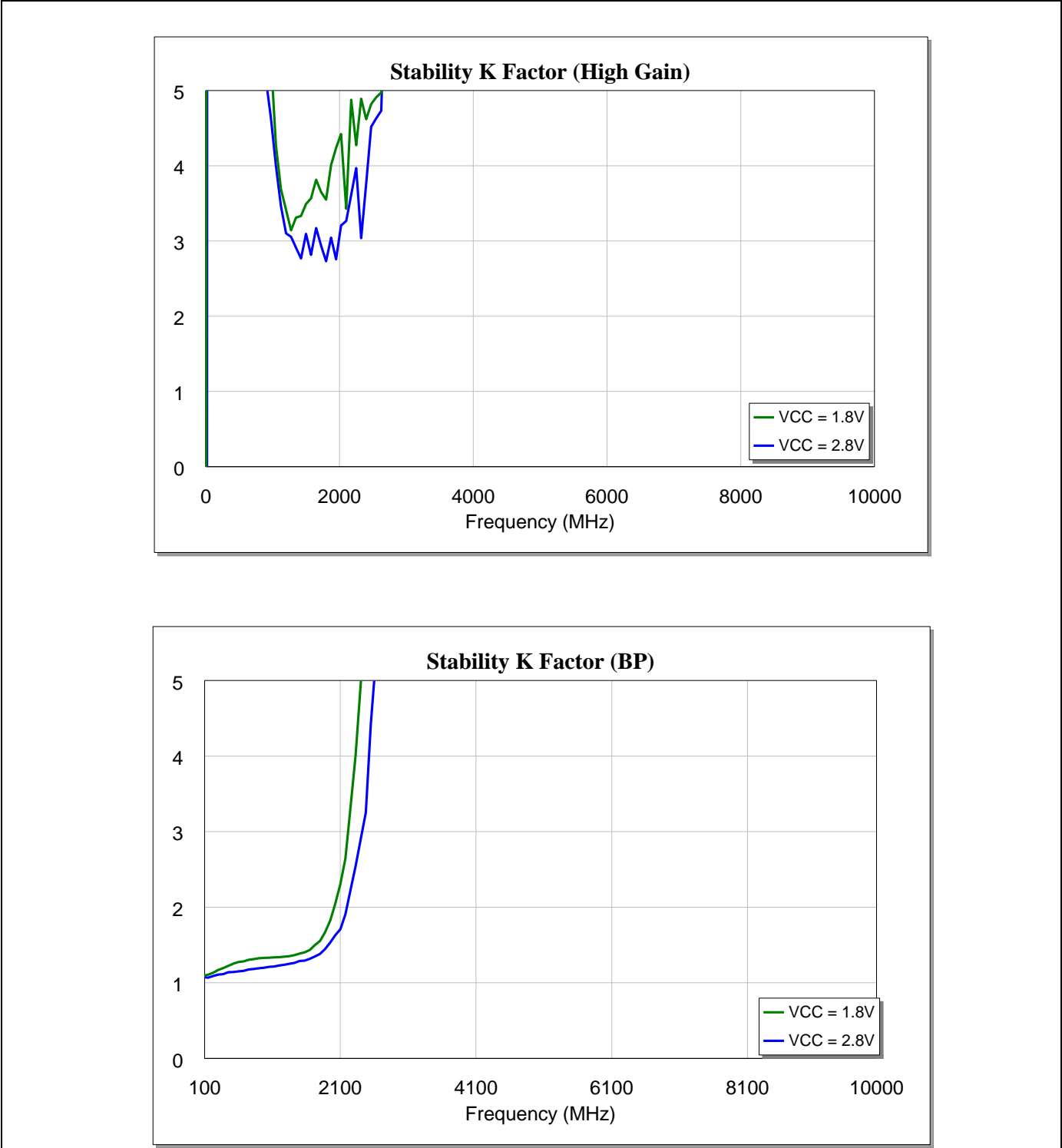

Figure 12 Stability K-factor of BGA5M1BN6 for GNSS applications

Measurement graphs

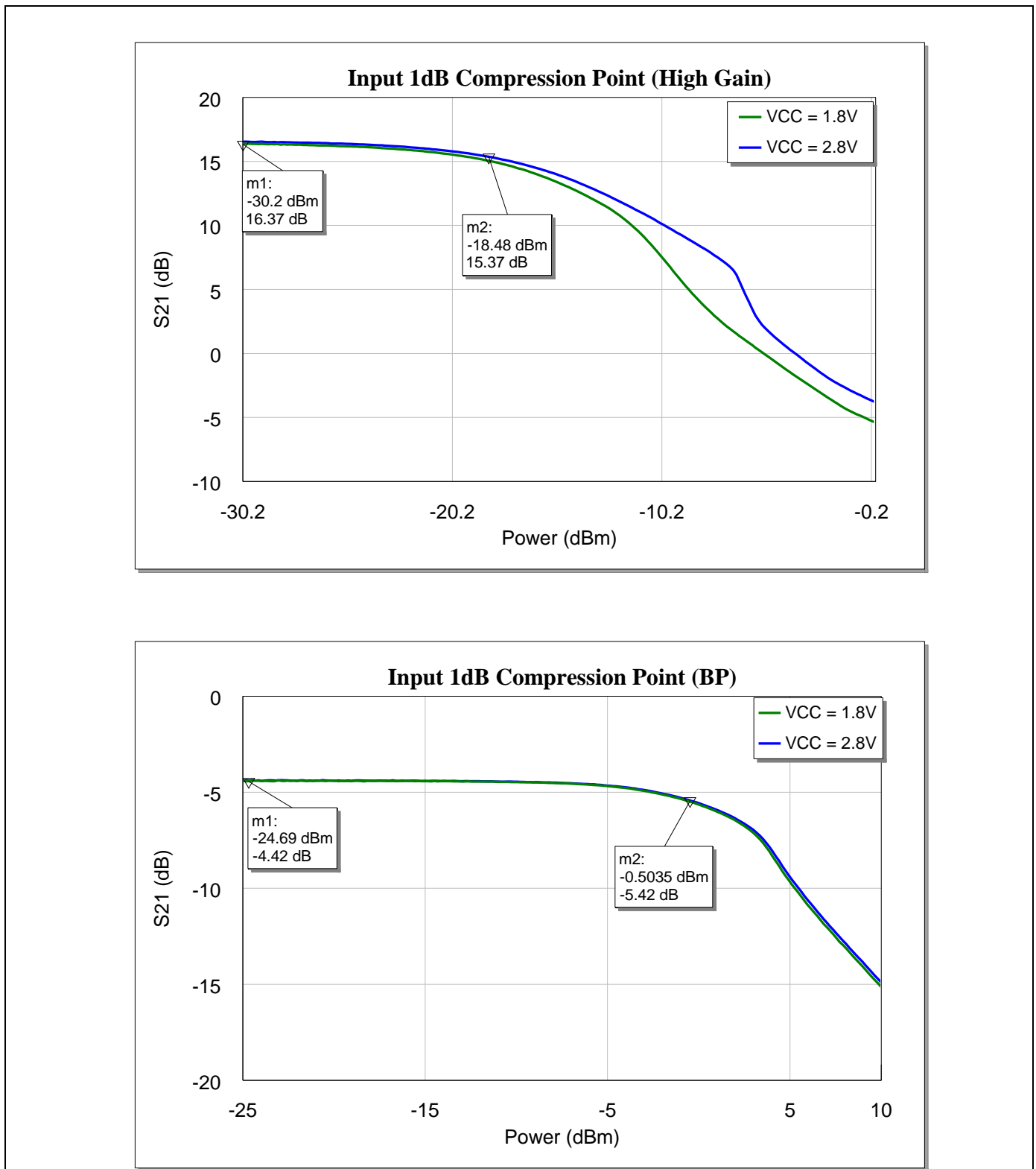

Figure 13 Input 1 dB compression point of BGA5M1BN6 for GNSS applications

Measurement graphs

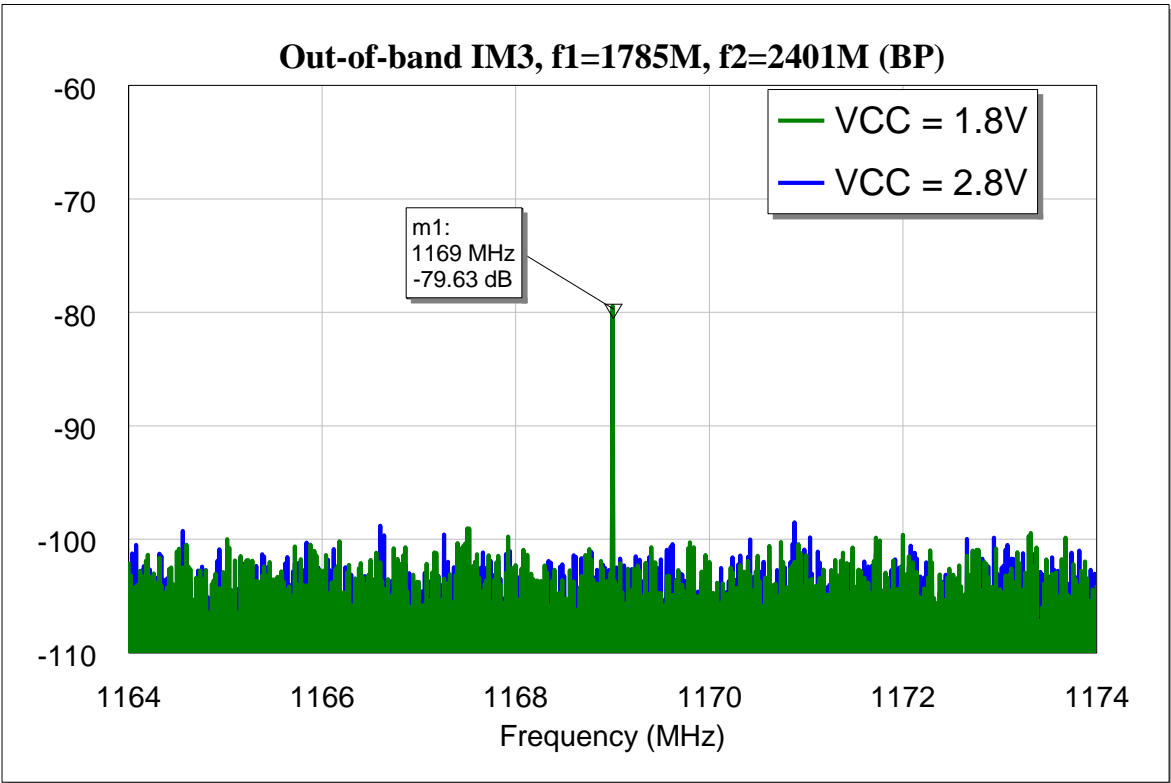
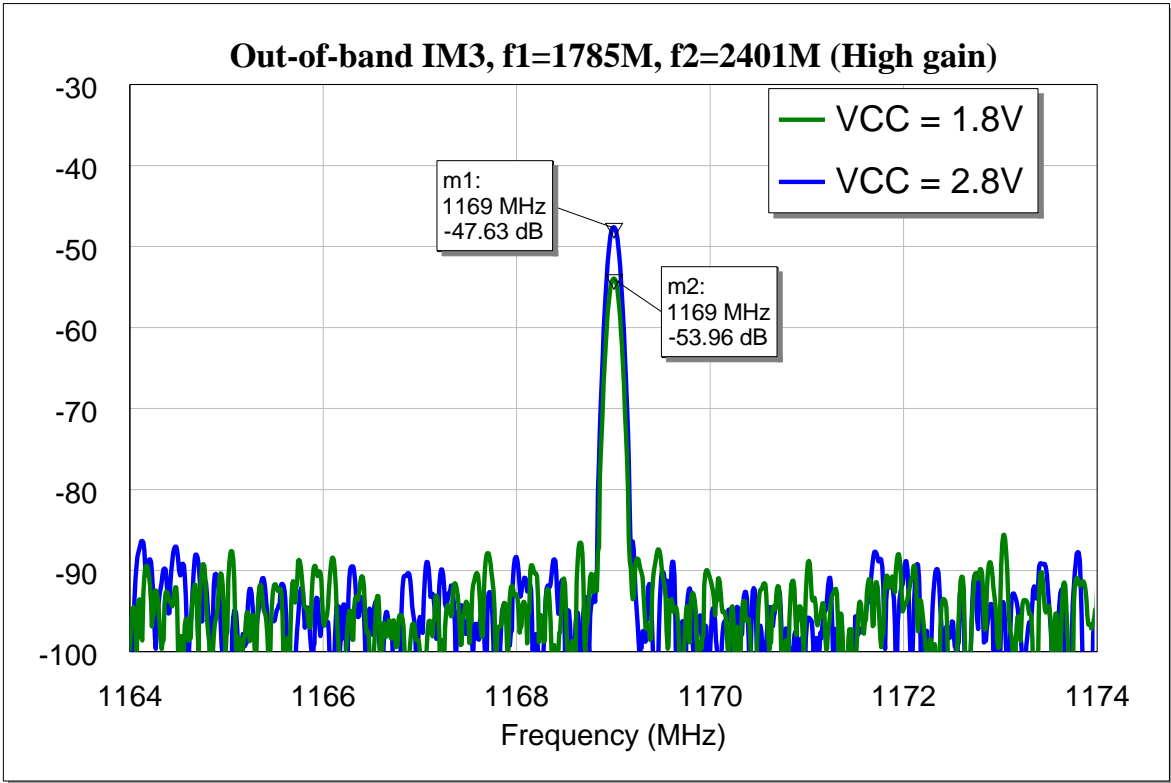

Figure 14 Out-of-band third-order intermodulation point of BGA5M1BN6 for GNSS applications (L5 band, output referred)

Measurement graphs

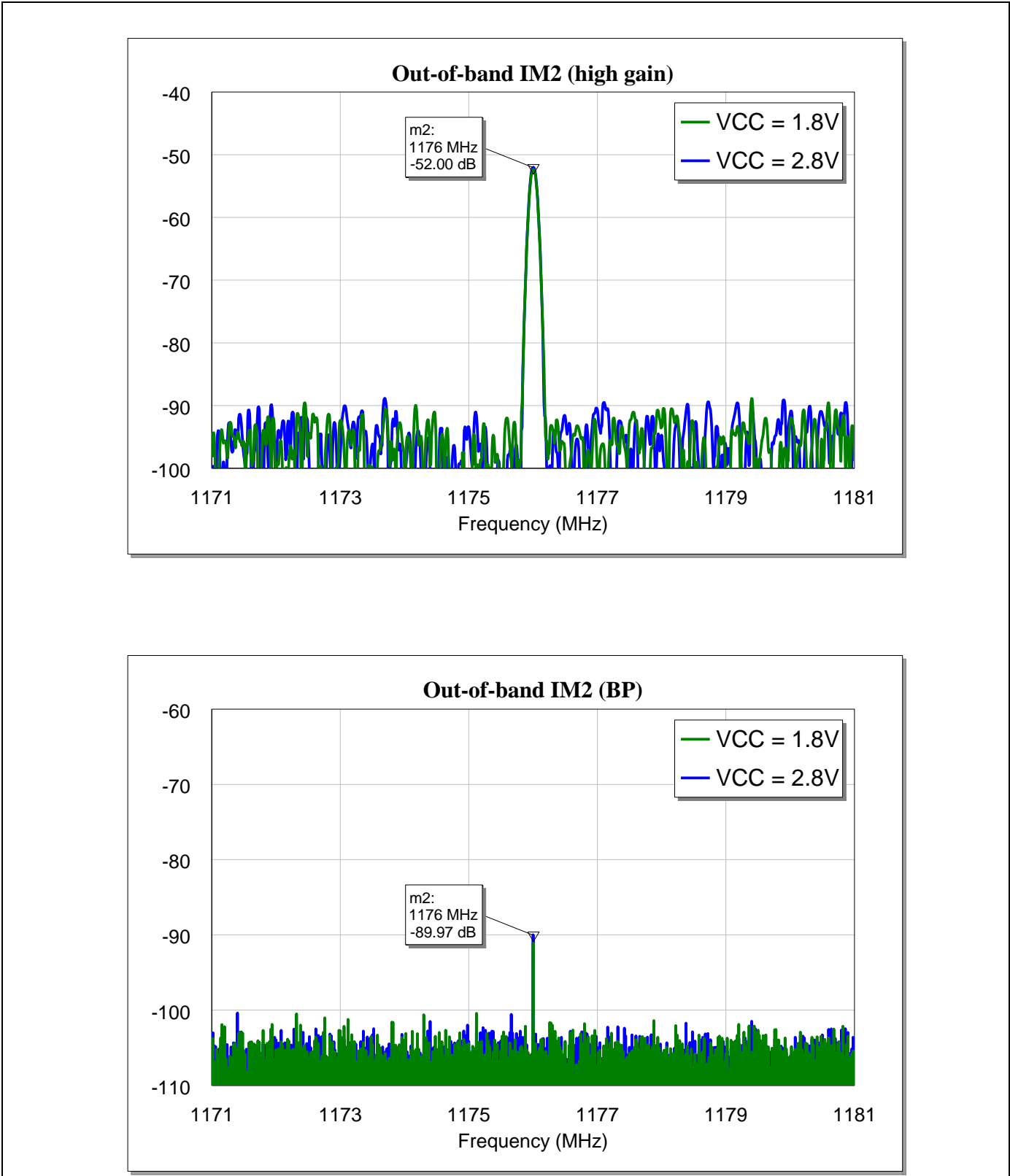

Figure 15 Out-of-band second-order intermodulation point of BGA5M1BN6 for GNSS applications (L5 band, output referred)

Measurement graphs

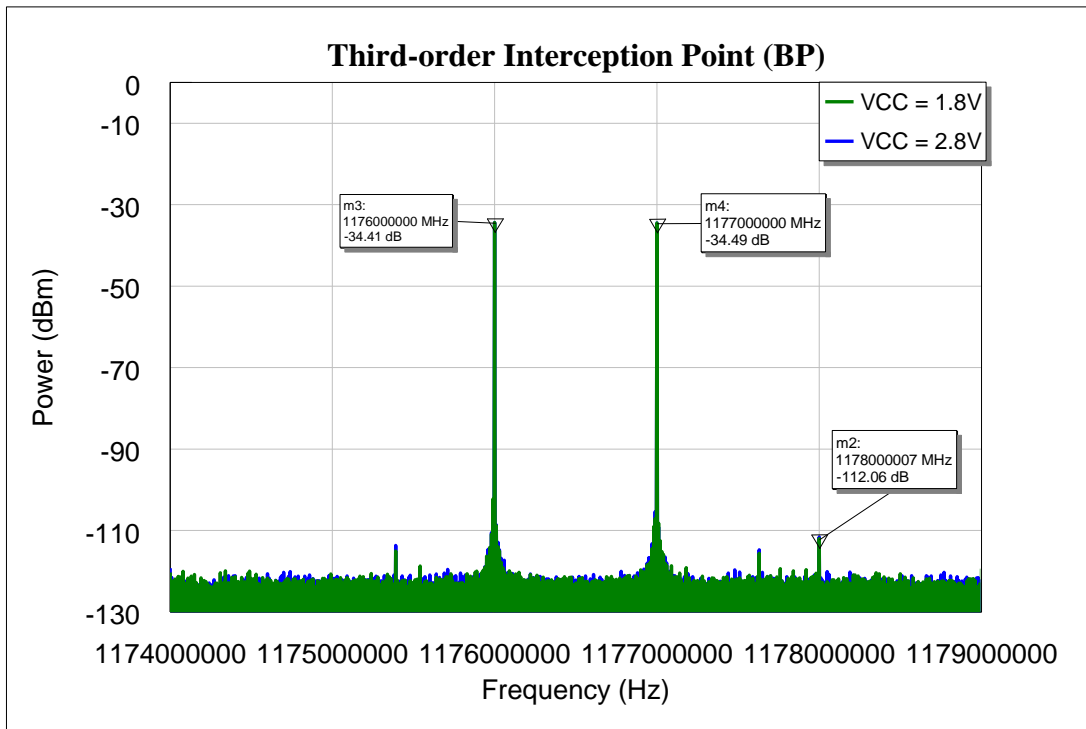
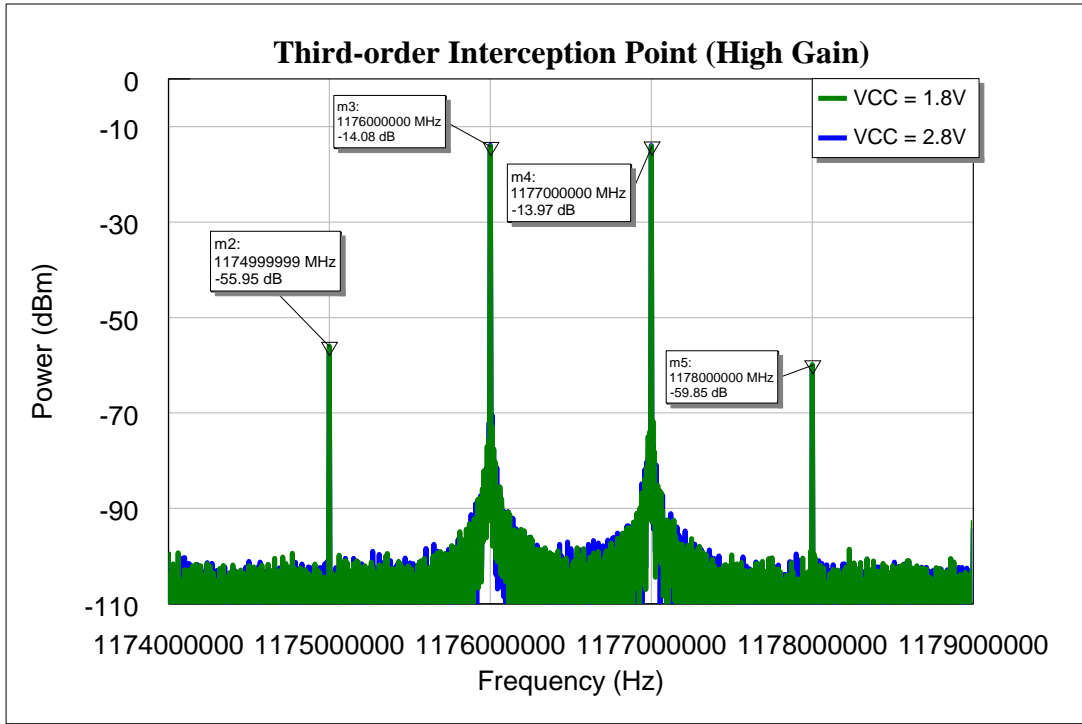

Figure 16 Inband third-order intermodulation point of BGA5M1BN6 for GNSS applications (output referred)

5 Evaluation board and layout information

In this application note, the following PCB is used:

PCB marking: **BGAxxxN6 V4.0**

PCB material: **FR4**

ϵ_r of PCB material: **4.8**

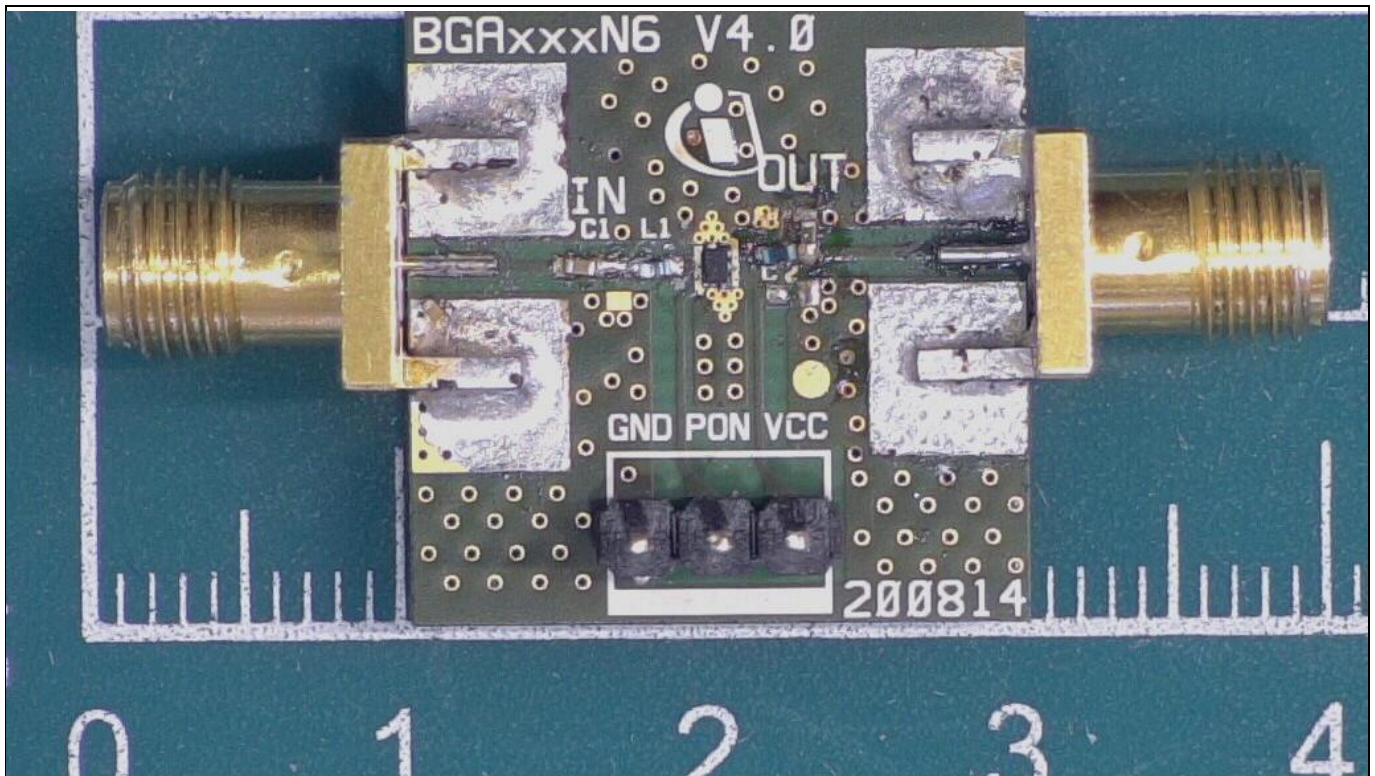

Figure 17 Evaluation board (overview)

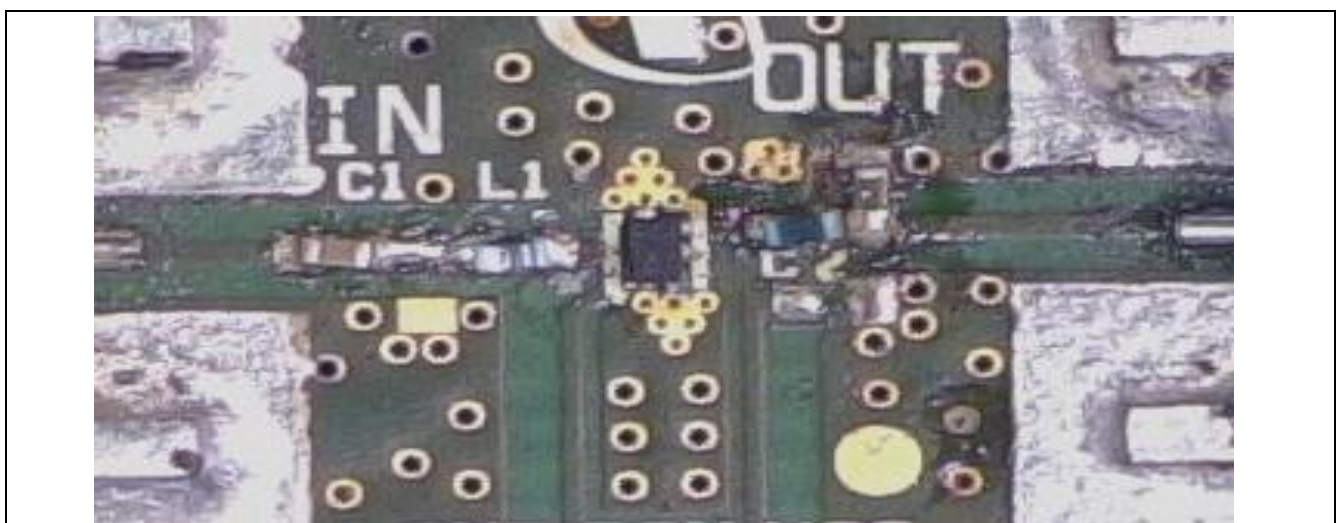

Figure 18 Evaluation board (detailed view)

BGA5M1BN6 as a Bypass LNA for GNSS applications from 1166 MHz to 1186 MHz



Evaluation board and layout information

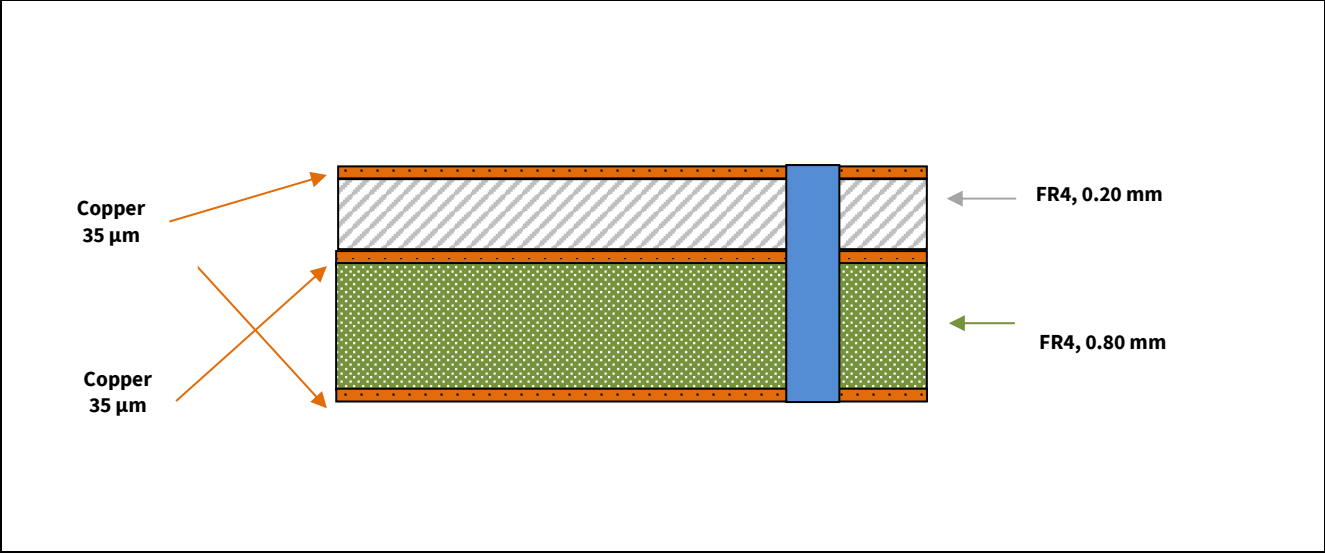

Figure 19 PCB layer information

6 Authors

Xiang Li, Senior Application Engineer of Business Unit “Radio Frequency and Sensors”

Horson Hao, Senior Application Engineer of Business Unit “Radio Frequency and Sensors”

Umar Md Yasir, Working Student of Business Unit “Radio Frequency and Sensors”

7

7 References

- [1] https://en.wikipedia.org/wiki/GPS_signals
- [2] <https://galileognss.eu/galileo-frequency-bands/>
- [3] http://www.navipedia.net/index.php/GNSS_signal
- [4] <https://www.gps.gov/systems/gps/modernization/civilsignals/>

8 Revision history

Major changes since the last revision

Page or reference	Description of change

Trademarks of Infineon Technologies AG

μ HVIC™, μ IPM™, μ PFC™, AU-ConvertIR™, AURIX™, C166™, CanPAK™, CIPOS™, CIPURSE™, CoolDP™, CoolGaN™, COOLiR™, CoolMOS™, CoolSET™, CoolSiC™, DAVE™, DI-POL™, DirectFET™, DrBlade™, EasyPIM™, EconoBRIDGE™, EconoDUAL™, EconoPACK™, EconoPIM™, EiceDRIVER™, eupec™, FCOS™, GaNpowIR™, HEXFET™, HITFET™, HybridPACK™, iMOTION™, IRAM™, ISOFACE™, IsoPACK™, LEDrivIR™, LITIX™, MIPAQ™, ModSTACK™, my-d™, NovalithIC™, OPTIGA™, OptiMOS™, ORIGA™, PowIRaudio™, PowIRstage™, PrimePACK™, PrimeSTACK™, PROFET™, PRO-SIL™, RASIC™, REAL3™, SmartLEWIS™, SOLID FLASH™, SPOC™, StrongIRFET™, SupIRBuck™, TEMPFET™, TRENCHSTOP™, TriCore™, UHVIC™, XHP™, XMC™

Trademarks updated November 2015

Other Trademarks

All referenced product or service names and trademarks are the property of their respective owners.

Edition 2020-04-20

Published by

Infineon Technologies AG

81726 Munich, Germany

© 2021 Infineon Technologies AG.

All Rights Reserved.

Do you have a question about this document?

Email: erratum@infineon.com

Document reference

AN_2004_PL55_2005_135800

IMPORTANT NOTICE

The information contained in this application note is given as a hint for the implementation of the product only and shall in no event be regarded as a description or warranty of a certain functionality, condition or quality of the product. Before implementation of the product, the recipient of this application note must verify any function and other technical information given herein in the real application. Infineon Technologies hereby disclaims any and all warranties and liabilities of any kind (including without limitation warranties of non-infringement of intellectual property rights of any third party) with respect to any and all information given in this application note.

The data contained in this document is exclusively intended for technically trained staff. It is the responsibility of customer's technical departments to evaluate the suitability of the product for the intended application and the completeness of the product information given in this document with respect to such application.

For further information on the product, technology, delivery terms and conditions and prices please contact your nearest Infineon Technologies office (www.infineon.com).

WARNINGS

Due to technical requirements products may contain dangerous substances. For information on the types in question please contact your nearest Infineon Technologies office.

Except as otherwise explicitly approved by Infineon Technologies in a written document signed by authorized representatives of Infineon Technologies, Infineon Technologies' products may not be used in any applications where a failure of the product or any consequences of the use thereof can reasonably be expected to result in personal injury.