

# BGA123L4 as Low Current Low Noise Amplifier for GNSS Applications in L5/E5/G3/L2/E2 bands

## About this document

### Scope and purpose

This application note describes Infineon's GNSS MMIC: BGA123L4 – a low-current low noise amplifier for GNSS applications in L5/E5/G3/L2/E2 bands (1164 to 1254 MHz). Thanks to the extremely low current consumption, this circuit supports to improve the sensitivity of low power GNSS RF frontends in wearable devices.

The BGA123L4 is a silicon germanium low noise amplifier supporting GNSS applications.

1. The target application is GNSS L5/E5/G3/L2/E2 band applications (1164 to 1254 MHz).
2. In this report, the performance of BGA123L4 is measured on a FR4 board. This device is matched with 0402 inch size LQW15 external components.
3. The circuit supports operation in both L2 and L5 bands by using two additional components for matching at the output side. If used for L2 band specifically, circuit needs just 1 inductor for matching at the output side.
4. Key performance parameters at 1.8 V, 1176 MHz (LQW15 inductors for matching)  
NF with LQP inductor = 1.2 dB  
NF with LQW inductor = 0.90 dB  
Insertion gain = 16.0 dB  
Input return loss = 11 dB  
Output return loss = 16 dB  
Out-of-band output IM3 at 1169 MHz = -64 dBm
5. Key performance parameters at 1.8 V, 1228 MHz (LQW15 inductors for matching)  
NF with LQP inductor = 1.25 dB  
NF with LQW inductor = 0.90 dB  
Insertion gain = 16.7 dB  
Input return loss = 11 dB  
Output return loss = 16 dB  
Out-of-band output IM3 at 1215 MHz = -65 dBm

# BGA123L4 as Low Current Low Noise Amplifier for GNSS Applications in L5/E5/G3/L2/E2 bands



## Introduction of Global Navigation Satellite Systems (GNSSs)

### Table of contents

<b>About this document</b> .....	<b>1</b>
<b>Table of contents</b> .....	<b>2</b>
<b>List of figures<sup>1</sup></b> .....	<b>3</b>
<b>List of tables</b> .....	<b>3</b>
<b>1 Introduction of Global Navigation Satellite Systems (GNSSs)</b> .....	<b>4</b>
1.1 Global Navigation Satellite Systems (GNSSs) .....	4
1.2 Lower L bands .....	4
1.2.1 Out-of-band interference.....	5
1.3 Infineon product portfolio for GNSS applications .....	6
1.4 Key features of GNSS low-noise amplifiers .....	6
1.4.1 Low noise figure and high gain .....	6
1.4.2 High robustness against coexistence of out-of-band jammer signals.....	6
1.4.3 Low current consumption .....	6
<b>2 BGA123L4 overview</b> .....	<b>7</b>
2.1 Features .....	7
2.2 Key applications of BGA123L4 .....	7
2.3 Description .....	7
<b>3 Application circuit and performance overview</b> .....	<b>9</b>
3.1 Summary of measurement results .....	9
3.2 Schematic and Bill of Materials (BOM) .....	12
<b>4 Measurement graphs</b> .....	<b>13</b>
<b>5 Evaluation board and layout information</b> .....	<b>22</b>
<b>6 Authors</b> .....	<b>24</b>
<b>7 References</b> .....	<b>25</b>
<b>Revision history</b> .....	<b>25</b>

### List of figures<sup>1</sup>

Figure 1	Application diagram: receiver front-end of the GNSS.....	4
Figure 2	Frequency allocation: GNSS systems, upper L bands and lower L bands .....	5
Figure 3	BGA123L4 in TSLP-4-11 .....	7
Figure 4	Package and pin connections of BGA123L4 .....	8
Figure 5	Schematic of the BGA123L4 application circuit.....	12
Figure 6	Insertion power gain (narrowband) of BGA123L4 for GNSS applications including L2 band (center frequency).....	13
Figure 7	Insertion power gain (wideband) of BGA123L4 for GNSS applications.....	13
Figure 8	NF of BGA123L4 for GNSS applications (SMA and connector losses de-embedded, LQW15 inductors for matching) .....	14
Figure 9	NF of BGA123L4 for GNSS applications (SMA and connector losses de-embedded, LQP03TN inductors for matching) .....	14
Figure 10	Input return loss of BGA123L4 for GNSS applications including L2 band (center frequency) .....	15
Figure 11	Input return loss (Smith chart) of BGA123L4 for GNSS applications (port de-embedded) .....	15
Figure 12	Output return loss of BGA123L4 for GNSS applications .....	16
Figure 13	Output return loss (Smith chart) of BGA123L4 for GNSS applications (port de-embedded) .....	16
Figure 14	Reverse isolation of BGA123L4 for GNSS applications including L2 band (center frequency).....	17
Figure 15	Stability K-factor of BGA123L4 for GNSS applications.....	17
Figure 16	Stability Mu1-factor, Mu2-factor of BGA123L4 for GNSS applications .....	18
Figure 17	Input 1 dB compression point of BGA123L4 for GNSS applications at L5 Centre frequency .....	18
Figure 18	Third-order interception point (1.2 V) of BGA123L4 for GNSS applications (output referred).....	19
Figure 19	Third-order interception point (1.8 V) of BGA123L4 for GNSS applications (output referred).....	19
Figure 20	Out-of-band third-order intermodulation point of BGA123L4 for GNSS applications at 1169 MHz (output referred) .....	20
Figure 21	Out-of-band third-order intermodulation point of BGA123L4 for GNSS applications at 1207 MHz (output referred) .....	20
Figure 22	Out-of-band third-order intermodulation point of BGA123L4 for GNSS applications at 1215 MHz (output referred) .....	21
Figure 23	Photo of evaluation board (overview).....	22
Figure 24	Photo of evaluation board (detailed view).....	22
Figure 25	PCB layer information .....	23

### List of tables

Table 1	Pin assignment of BGA123L4 .....	8
Table 2	Mode selection of BGA123L4.....	8
Table 3	Electrical characteristics at 1.8 V (at room temperature).....	9
Table 4	Electrical characteristics at 1.2 V (at room temperature).....	11
Table 5	Bill Of Materials.....	12

1) The graphs are generated with the simulation program AWR Microwave Office®.

## Introduction of Global Navigation Satellite Systems (GNSSs)

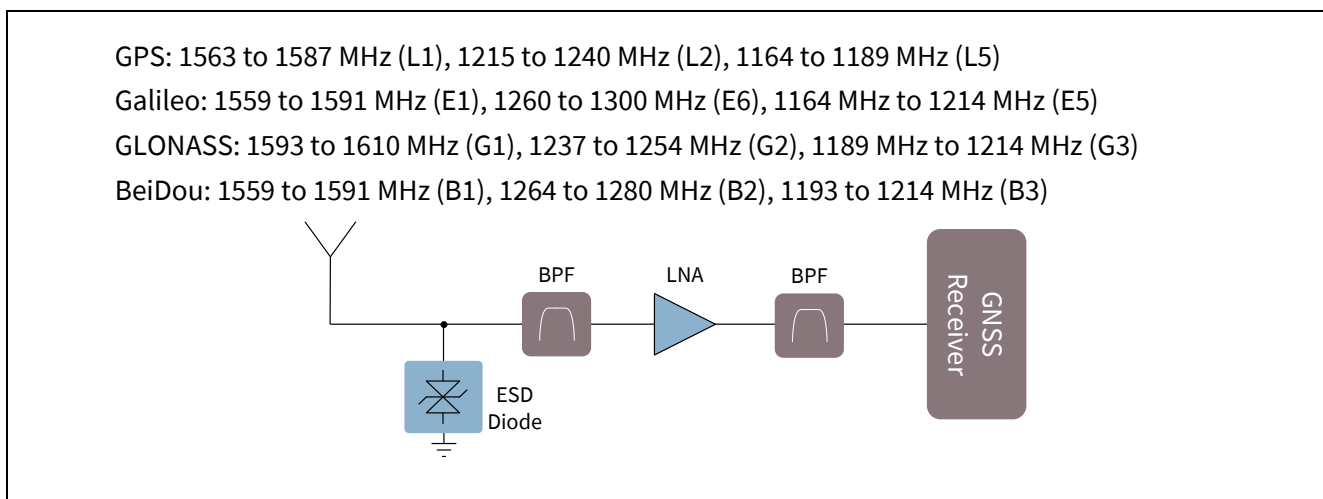
### 1 Introduction of Global Navigation Satellite Systems (GNSSs)

#### 1.1 Global Navigation Satellite Systems (GNSSs)

Global Navigation Satellite Systems (GNSSs) are among the fastest growing businesses in the electronic industry. Today, four GNSS systems are in operation: the United States GPS, the Russian GLobal Orbiting Navigation Satellite System (GLONASS), the Chinese BeiDou Navigation Satellite System (BDS) and the European Union Galileo navigation system. Main market segments include the Personal Navigation Devices (PNDs), GNSS-enabled mobile phones and GNSS-enabled portable devices.

The main challenges for the growing GNSS-enabled mobile phone segment are to achieve high sensitivity and high immunity defined by government regulations against interference of cellular signals for safety and emergency reasons. This means GNSS signals must be received at very low power levels (down to less than -130 dBm) in mobile phones in the vicinity of co-existing high-power cellular signals.

The main challenges for the GNSS-enabled portable devices are to obtain a long battery operation time, and low Time-To-First Fix (TTFF) to quickly locate the device.



**Figure 1 Application diagram: receiver front-end of the GNSS**

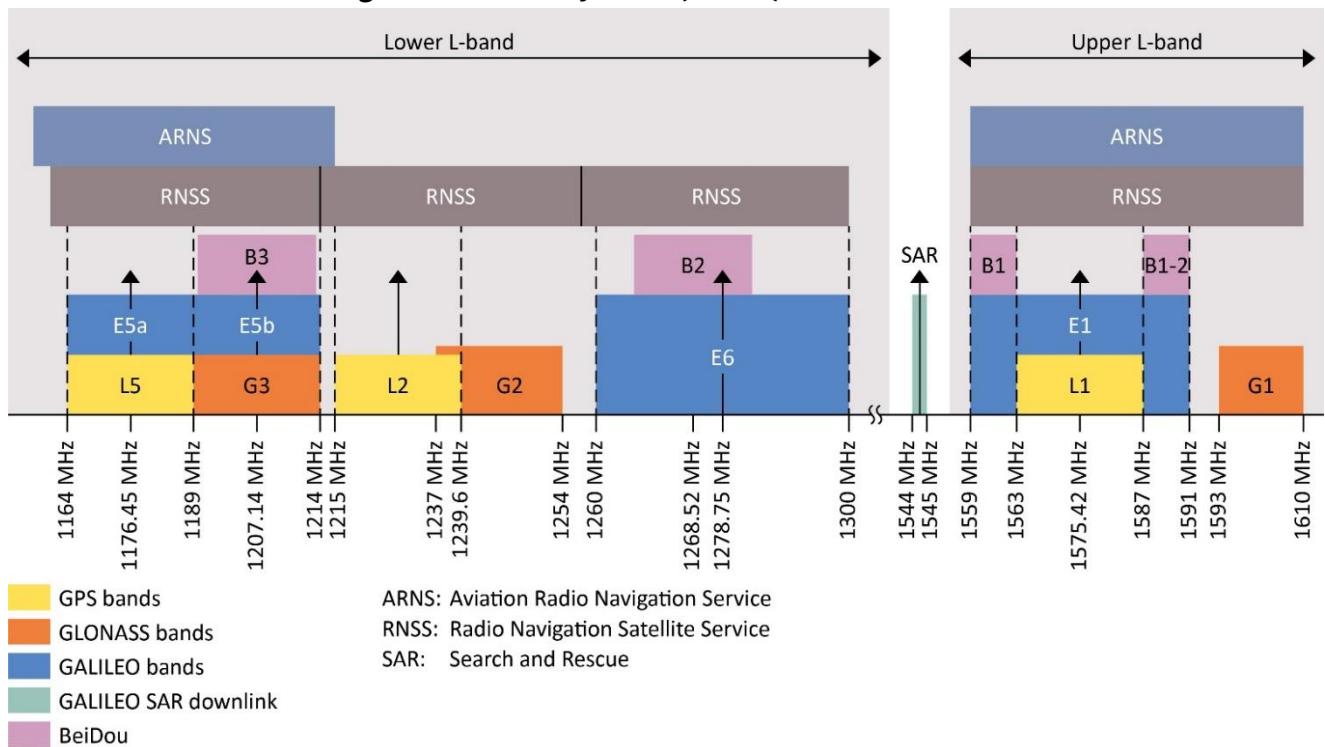
#### 1.2 Lower L bands

Most existing GNSS systems operate in the upper L band (1559 to 1610 MHz). Recently, GNSS applications in the lower L bands (1164 to 1299 MHz) have started to emerge.

The lower L bands include BDS B3 / Galileo E5 / GLONASS G3 / GPS L5 bands (1164 MHz to 1214 MHz), and BDS B2 / Galileo E6 / GLONASS G2 / GPS L2 bands (1215 MHz to 1300 MHz). The GPS L5 band hosts a civilian safety-of-life signal, and is intended to provide a means of radio navigation secure and robust enough for life-critical applications, such as aircraft precision approach guidance. India's Indian Regional Navigation Satellite System (IRNSS) also operates in the L5 band. The L2 band has been used for high-precision location navigation.

Figure 2 on next page demonstrates an overview of the GNSS frequency allocation:

**Introduction of Global Navigation Satellite Systems (GNSSs)**



**Figure 2 Frequency allocation: GNSS systems, upper L bands and lower L bands**

**1.2.1 Out-of-band interference**

Because GNSS and cellular systems co-exist in a compact area in a mobile phone, coupling from the cellular transmitter to the GNSS receive path results in intermixing of other high-frequency signals in GNSS FE devices; for example, intermodulation between LTE band 2 and band 3 signals, intermodulation between LTE band 5 and WLAN 2.4 GHz signals, etc.

In the example below, the LTE band 3 signal ( $f_{1IN}$ ) and LTE band 40 signal ( $f_{2IN}$ ) produce third-order intermodulation products at GPS frequencies. This effect desensitizes the GPS receiver and decreases its performance. When  $f_{1IN} = 1785$  MHz and power  $P_{1IN} = -25$  dBm, and  $f_{2IN} = 2401$  MHz and power  $P_{2IN} = -25$  dBm are used, the third-order intermodulation product,  $2 \times f_{1IN} - f_{2IN}$ , is located at 1169 MHz. This signal is referred to as Out-of-Band Output IM3 (OoB OIM3). As to the OoB OIM3 input referred, the OoB Input IM3 (OoB IIM3) can be calculated as:

$$OoB\ IIM3 = OoB\ OIM3 - Gain\ at\ 1169\ MHz$$

As an example, if the OoB OIM3 of the device at 1169 MHz is -61.2 dBm and the gain of the amplifier at 1169 MHz is 16.1 dB, then the OoB IIM3 is calculated as:

$$OoB\ IIM3 = -61.2 - 16.1 = -77.3\ dBm$$

## Introduction of Global Navigation Satellite Systems (GNSSs)

### 1.3 Infineon product portfolio for GNSS applications

Infineon Technologies is among the market leaders in GNSS Low Noise Amplifiers (LNAs) for navigation applications. We offer the following product portfolio to all customers designing high-performance flexible RF front-end solutions for all GNSS systems:

- **Low Noise Amplifiers (LNAs):** Infineon offers a wide range of products such as high-performance Monolithic Microwave Integrated Circuits (MMICs) as well as cost-effective and high-end RF transistors.
- **Transient Voltage Suppression (TVS) diodes:** Infineon devices can protect GNSS antennas reliably up to 20 kV.

### 1.4 Key features of GNSS low-noise amplifiers

Infineon is among the leading suppliers for GNSS Low Noise Amplifiers (LNAs) for navigation applications. The GNSS MMIC LNAs are designed with below features:

#### 1.4.1 Low noise figure and high gain

The power levels of satellite signals received by a GNSS receiver are as low as -130 dBm. An external LNA with exceptionally low NF and good gain helps to boost the sensitivity of the system. The portfolio includes devices with various gain levels to tailor to the customer's RF systems.

#### 1.4.2 High robustness against coexistence of out-of-band jammer signals

In the presence of very weak GNSS satellite signals, there is no inband interference signal in the GNSS receiver frontends.

In case of mobile phone systems, GNSS signals coexist with strong jammer signals from other RF applications, e.g. 3G/4G, wireless LAN, etc. The above out-of-band jammer signals can mix to produce intermodulation products in the GNSS receiver frequency band. Compared with the received signal level from GNSS satellites, the resulted intermodulation products are significant interference, LNAs with high robustness against out-of-band interference signals are required.

#### 1.4.3 Low current consumption

Power consumption is an important feature in many GNSS systems that are mainly battery-operated mobile devices. Infineon's LNAs have an integrated power on/off feature which provides for low power consumption and increased stand-by time for GNSS handsets. Moreover, the recent development has focused on low current (e.g. 1.1 mA) and low supply voltage (1.2 V), making the LNAs suitable for portable devices such as GNSS enabled wearables and connected IoT devices.

Please visit [www.infineon.com](http://www.infineon.com) for more details on LNA products for navigation in mobile phones and portable devices.

## BGA123L4 overview

## 2 BGA123L4 overview

### 2.1 Features

- Operating frequencies: 1550 to 1615 MHz
- Ultra-low current consumption: 1.1 mA
- Wide supply voltage range: 1.1 to 3.6 V
- High insertion power gain: 18.2 dB
- Low NF: 0.75 dB
- 2 kV HBM ESD protection (including AI pin)
- Ultra-small TSLP-4-11 leadless package (footprint:  $0.7 \times 0.7 \times 0.31 \text{ mm}^3$ )
- RF output internally matched to  $50 \Omega$
- Only one external SMD component necessary
- Pb-free (RoHS compliant) package
- B7HF silicon germanium technology

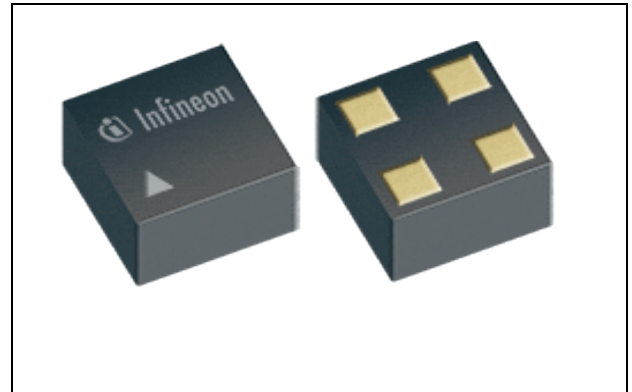


Figure 3 BGA123L4 in TSLP-4-11



### 2.2 Key applications of BGA123L4

BGA123L4 is designed to enhance GNSS signal sensitivity especially in wearables and mobile cellular IoT devices. With 18.2 dB gain and only 0.75 dB NF it ensures high system sensitivity. The current needed is only 1.1 mA, which means just 1.3 mW power consumption, which is critical to help to conserve batteries. The wide supply voltage range of 1.1 to 3.6 V ensures flexible design and high compatibility. It supports all GNSS systems including GPS, GLONASS, BeiDou, Galileo, QZSS, IRNSS.

### 2.3 Description

The BGA123L4 is an ultra-low noise amplifier for Global Navigation Satellite Systems (GNSS) which covers all GNSS frequency bands from 1550 to 1615 MHz, such as GPS, GLONASS, BeiDou, Galileo and others. The LNA provides 18.2 dB gain and 0.75 dB NF at a current consumption of only 1.1 mA in the application configuration described in Figure 4. The BGA123L4 is based on Infineon Technologies' B7HF silicon germanium technology. It operates from 1.1 to 3.6 V supply voltage.

# BGA123L4 as Low Current Low Noise Amplifier for GNSS Applications in L5/E5/G3/L2/E2 bands



## BGA123L4 overview

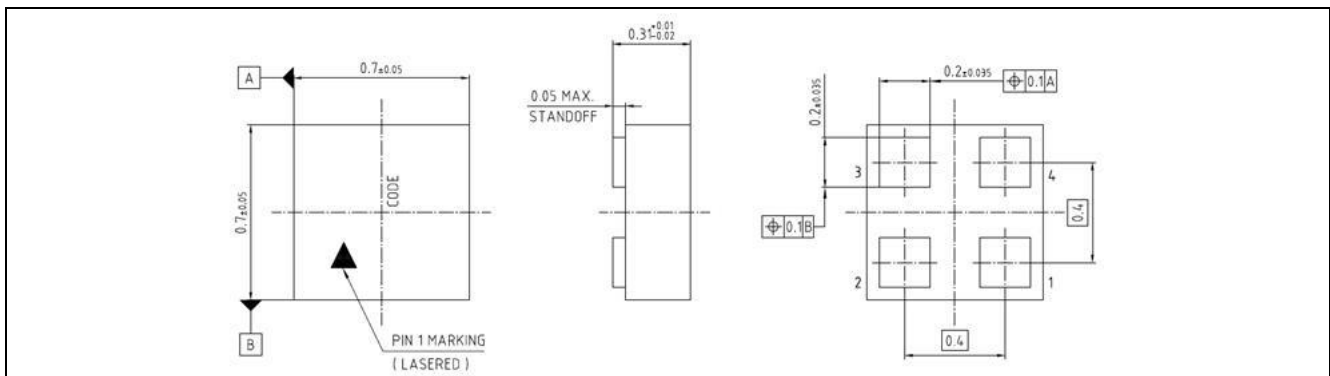


Figure 4 Package and pin connections of BGA123L4

Table 1 Pin assignment of BGA123L4

Pin no.	Symbol	Function
1	V <sub>CC</sub>	DC supply
2	AO	LNA output
3	GND	Ground
4	AI	LNA input

Table 2 Mode selection of BGA123L4

To select the mode for BGA123L4, one option is to control the mode directly via the V<sub>CC</sub> pin; an alternative option is to connect the the V<sub>CC</sub> pin to the GPIO port. The table below provides the voltage range required at the V<sub>CC</sub> pin to set the device to on or off mode.

LNA mode	On/off control voltage at V <sub>CC</sub> pin	
	Min.	Max.
ON	1.1 V	3.6 V
OFF	0 V	0.4 V

Please visit the product page of BGA123L4 for more information.



### 3 Application circuit and performance overview

In this chapter the performance of the application circuit, the schematic and the Bill of Materials (BOM) are presented.

**Device:** BGA123L4

**Application:** Low-noise amplifier for GNSS applications in L5/E5/G3/L2/E2 bands

**PCB marking:** GL05 V 1.2 A

**EVB order no.:** AN572

#### 3.1 Summary of measurement results

The performance of BGA123L4 for GNSS applications is summarized in the following table.

**Table 3 Electrical characteristics at 1.8 V (at room temperature)**

Parameter	Symbol	Value				Unit	Comment/test condition
Frequency range	Freq	1176	1214	1228	1254	MHz	E5/L5/G3/L2/E2 Bands
DC voltage	V <sub>CC</sub>	1.8				V	
DC current	I <sub>CC</sub>	1.1				mA	
Gain	G	16.0	16.6	16.7	16.6	dB	
Noise Figure	NF	1.20	1.20	1.25	1.25	dB	LQP03T inductor for matching, loss of input line of 0.1 dB is de-embedded
Noise Figure	NF	0.90	0.90	0.90	0.95	dB	LQW15 inductor for matching, loss of input line of 0.1 dB is de-embedded
Input return loss	RL <sub>in</sub>	11.0	11.7	11.6	11.2	dB	
Output return loss	RL <sub>out</sub>	15.7	20.4	15.9	11.2	dB	
Reverse isolation	I <sub>Rev</sub>	34.6	34.7	34.6	35.1	dB	
Input P1dB	IP1dB	-18		-17.5		dBm	Measured at 1176 / 1228 MHz
Output P1dB	OP1dB	-2.4		-1.0		dBm	
Input IP3	IIP3	-17.0				dBm	Power at input: -30 dBm f1 = 1176.5 MHz, f2 = 1177.5 MHz
Output IP3	OIP3	-0.4				dBm	
Input IP3	IIP3	-17.0				dBm	Power at input: -30 dBm f1 = 1227.6 MHz, f2 = 1228.6 MHz
Output IP3	OIP3	-0.4				dBm	
Out-of-Band Input IM3 <sup>1)</sup>	OoB_IIM3	-80.9				dBm	Power at input: -25 dBm f1 = 1785 MHz, f2 = 2401 MHz OoB_OIM3 measured at 1169 MHz
Out-of-Band Output IM3	OoB_OIM3	-64.3				dBm	
Out-of-Band Input IM3 <sup>1)</sup>	OoB_IIM3	-82.9				dBm	Power at input: -25 dBm

# BGA123L4 as Low Current Low Noise Amplifier for GNSS Applications in L5/E5/G3/L2/E2 bands



## Application circuit and performance overview

**Table 3 Electrical characteristics at 1.8 V (at room temperature)**

Parameter	Symbol	Value	Unit	Comment/test condition
Out-of-Band Output IM3	OoB_OIM3	-66.3	dBm	f1 = 1850 MHz, f2 = 2493 MHz OoB_OIM3 measured at 1207 MHz
Out-of-Band Input IM3 <sup>1)</sup>	OoB_IIM3	-82.7	dBm	Power at input: -25 dBm
Out-of-Band Output IM3	OoB_OIM3	-65.1	dBm	f1 = 1850 MHz, f2 = 2485 MHz OoB_OIM3 measured at 1215 MHz
Stability	K	More than 1	-	Measured up to 10 GHz

1) Out-of-band Input IMx = IM level output referred – Gain @ the measured frequency

# BGA123L4 as Low Current Low Noise Amplifier for GNSS Applications in L5/E5/G3/L2/E2 bands



## Application circuit and performance overview

**Table 4 Electrical characteristics at 1.2 V (at room temperature)**

Parameter	Symbol	Value				Unit	Comment/test condition
Frequency range	Freq	1176	1214	1228	1254	MHz	E5/L5/G3/L2/E2 Bands
DC voltage	V <sub>CC</sub>	1.2				V	
DC current	I <sub>CC</sub>	1.1				mA	
Gain	G	16.0	16.4	16.4	16.2	dB	
Noise Figure	NF	1.25	1.25	1.25	1.25	dB	LQP03T inductor for matching, loss of input line of 0.1 dB is de-embedded
Noise Figure	NF	0.90	0.90	0.90	0.95	dB	LQW15 inductor for matching, loss of input line of 0.1 dB is de-embedded
Input return loss	RL <sub>in</sub>	10.7	11.2	11.1	10.6	dB	
Output return loss	RL <sub>out</sub>	16.3	20.4	15.9	11.2	dB	
Reverse isolation	I <sub>Rev</sub>	34.5	34.6	34.7	35.1	dB	
Input P1dB	IP1dB	-19		-18		dBm	Measured at 1176 / 1228 MHz
Output P1dB	OP1dB	-2.6		-1.8		dBm	
Input IP3	IIP3	-17.0				dBm	Power at input: -30 dBm f1 = 1176.5 MHz, f2 = 1177.5 MHz
Output IP3	OIP3	-0.6				dBm	
Input IP3	IIP3	-17.0				dBm	Power at input: -30 dBm f1 = 1227.6 MHz, f2 = 1228.6 MHz
Output IP3	OIP3	-0.6				dBm	
Out-of-Band Input IM3 <sup>1)</sup>	OoB_IIM3	-81.0				dBm	Power at input: -25 dBm f1 = 1785 MHz, f2 = 2401 MHz OoB_OIM3 measured at 1169 MHz
Out-of-Band Output IM3	OoB_OIM3	-64.6				dBm	
Out-of-Band Input IM3 <sup>1)</sup>	OoB_IIM3	-81.6				dBm	Power at input: -25 dBm f1 = 1850 MHz, f2 = 2485 MHz OoB_OIM3 measured at 1215 MHz
Out-of-Band Output IM3	OoB_OIM3	-65.2				dBm	
Out-of-Band Input IM3 <sup>1)</sup>	OoB_IIM3	-82.9				dBm	Power at input: -25 dBm f1 = 1850 MHz, f2 = 2493 MHz OoB_OIM3 measured at 1207 MHz
Out-of-Band Output IM3	OoB_OIM3	-66.5				dBm	
Stability	K	More than 1				-	Measured up to 10 GHz

1) Out-of-band Input IMx = IM level output referred – Gain @ the measured frequency

# BGA123L4 as Low Current Low Noise Amplifier for GNSS Applications in L5/E5/G3/L2/E2 bands



## Application circuit and performance overview

### 3.2 Schematic and Bill of Materials (BOM)

The schematic of BGA123L4 for GNSS applications is presented in Figure 5 and its bill-of-materials is shown in Table 6.

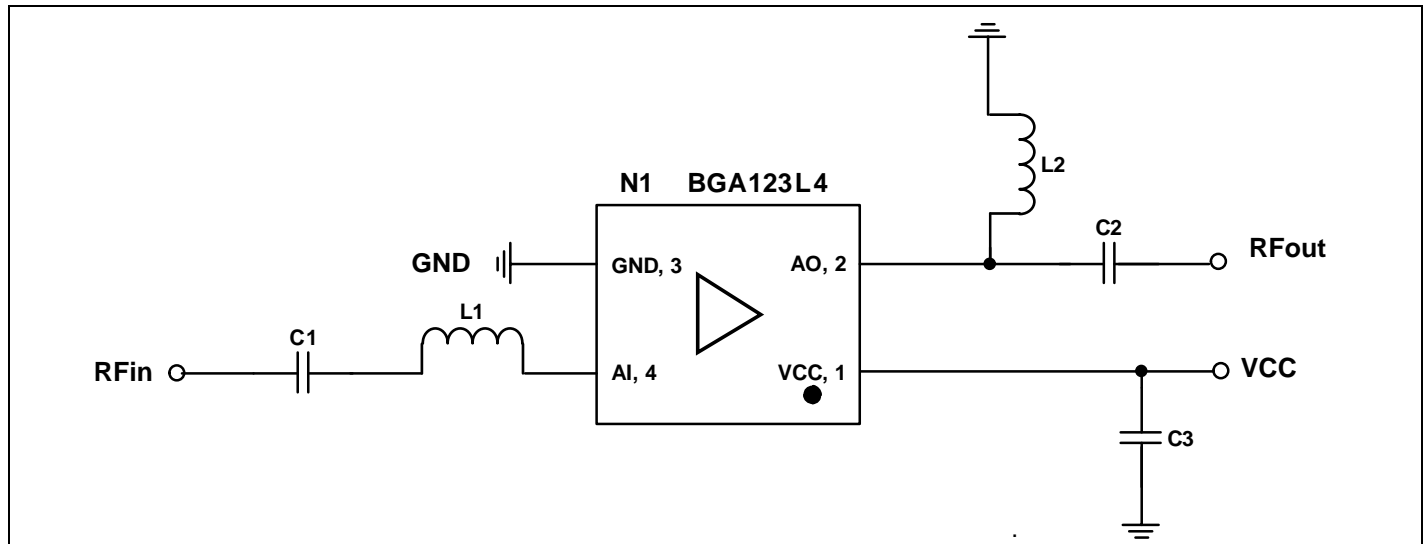


Figure 5 Schematic of the BGA123L4 application circuit

Table 5 Bill Of Materials

Symbol	Value	Unit	Size	Manufacturer	Comment
C1	1	nF	0402/0201	Various	DC block (optional)
C2	3.6 <sup>1)</sup>	pF	0402/0201	Various	Output matching (optional)
C3	1	nF	0402/0201	Various	RF bypass (optional)
L1	18	nH	0402/0201	Murata LQW15/LQP03TN	Input matching
L2	3.0 <sup>1)</sup> / 3.6 <sup>2)</sup>	nH	0402/0201	Murata LQW15/LQP03TN	Output matching
N1	BGA123L4	TSLP-4-11		Infineon Technologies	SiGe LNA

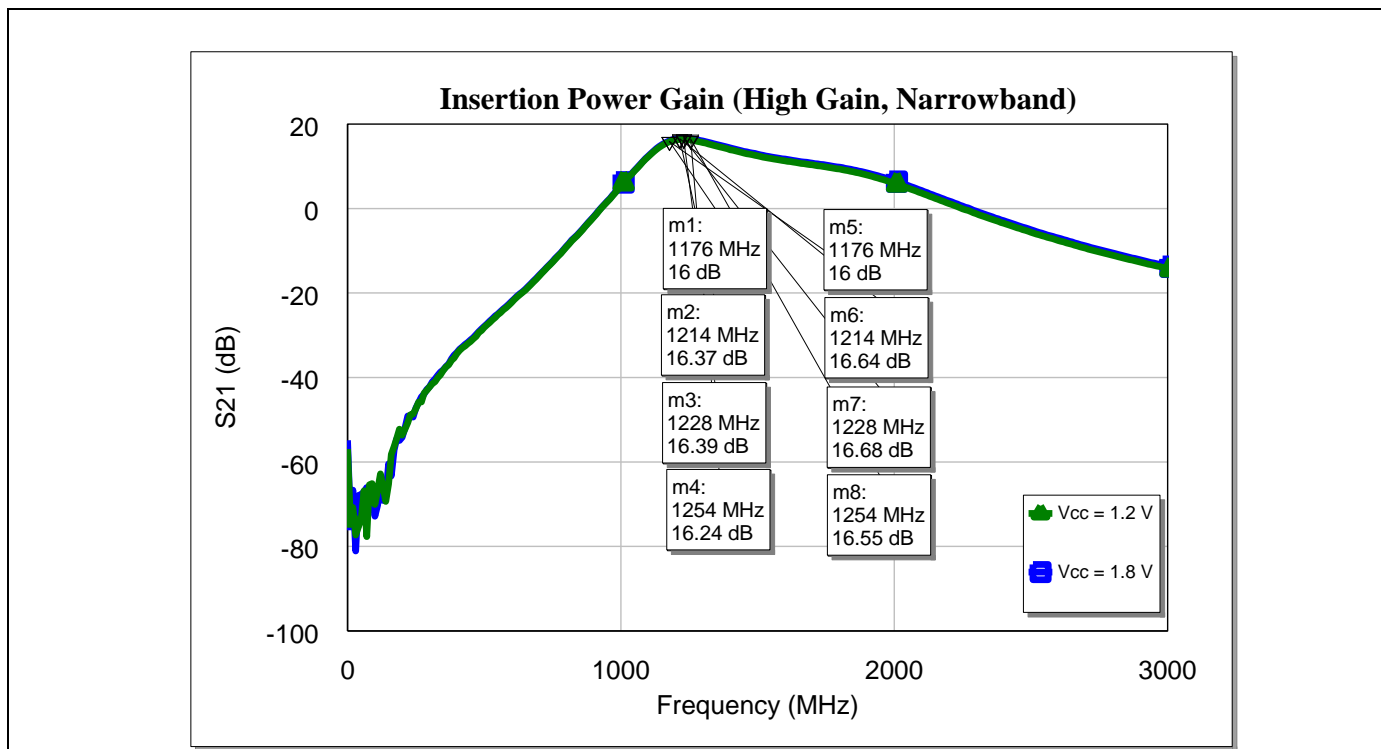
Note: 1) These values C2, L2 are for operation both in the L2 and L5 bands.

2) This value of L2 is for operation only in the L2 band, capacitor C2 can be removed for operation only in the L2 Band.

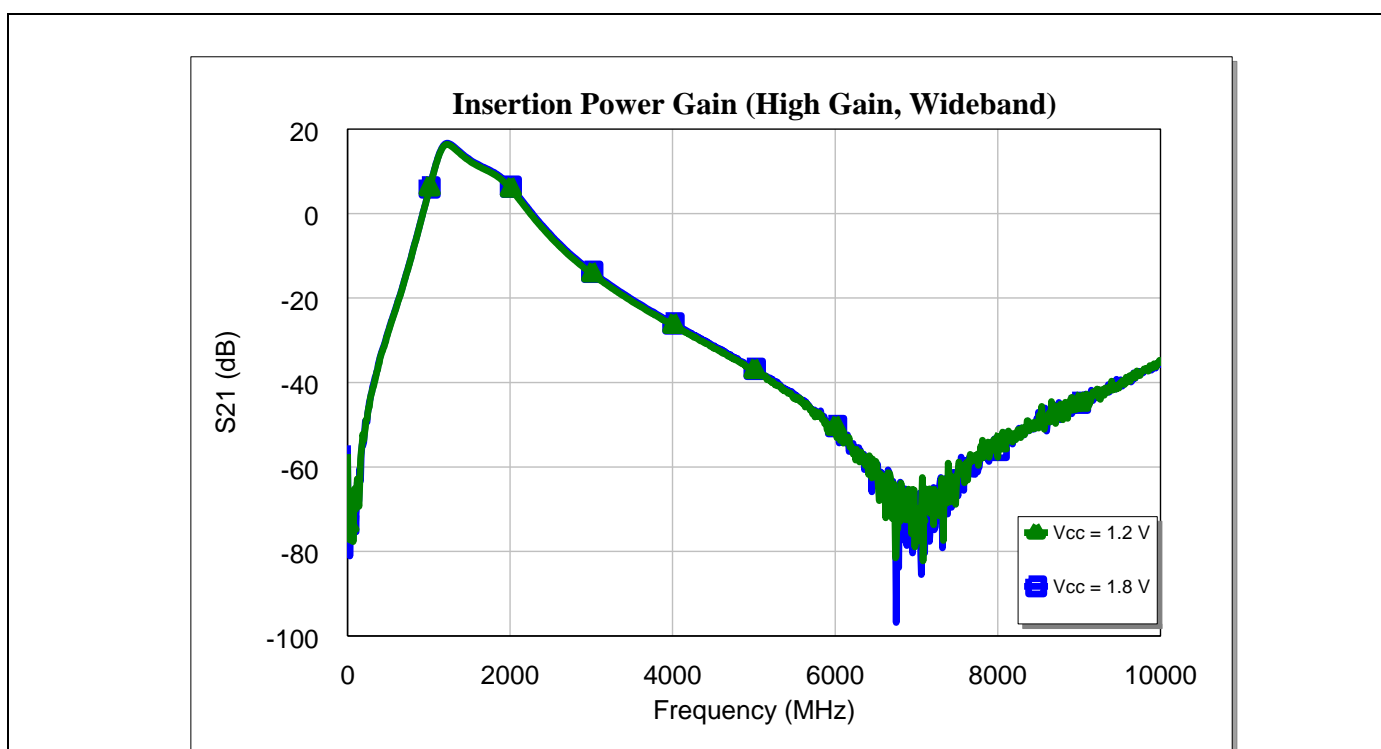
Note: DC block function is NOT integrated at the input of BGA123L4. The DC block might be realized with pre-filter in GNSS applications.

The RF bypass capacitor C3 at the DC power supply pin filters out the power supply noise and stabilizes the DC supply. The C3 is not necessary if a clean and stable DC supply can be ensured.

## 4 Measurement graphs

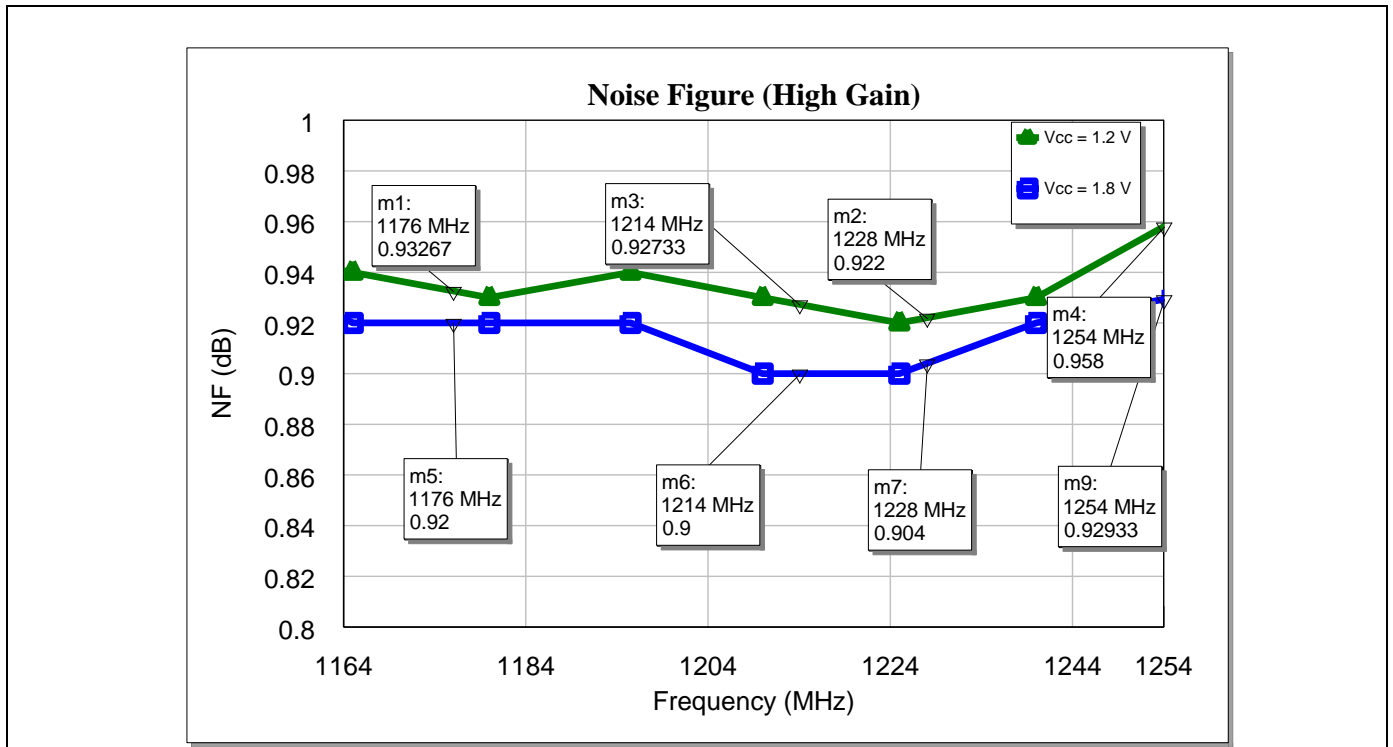


**Figure 6** Insertion power gain (narrowband) of BGA123L4 for GNSS applications including L2 band (center frequency)

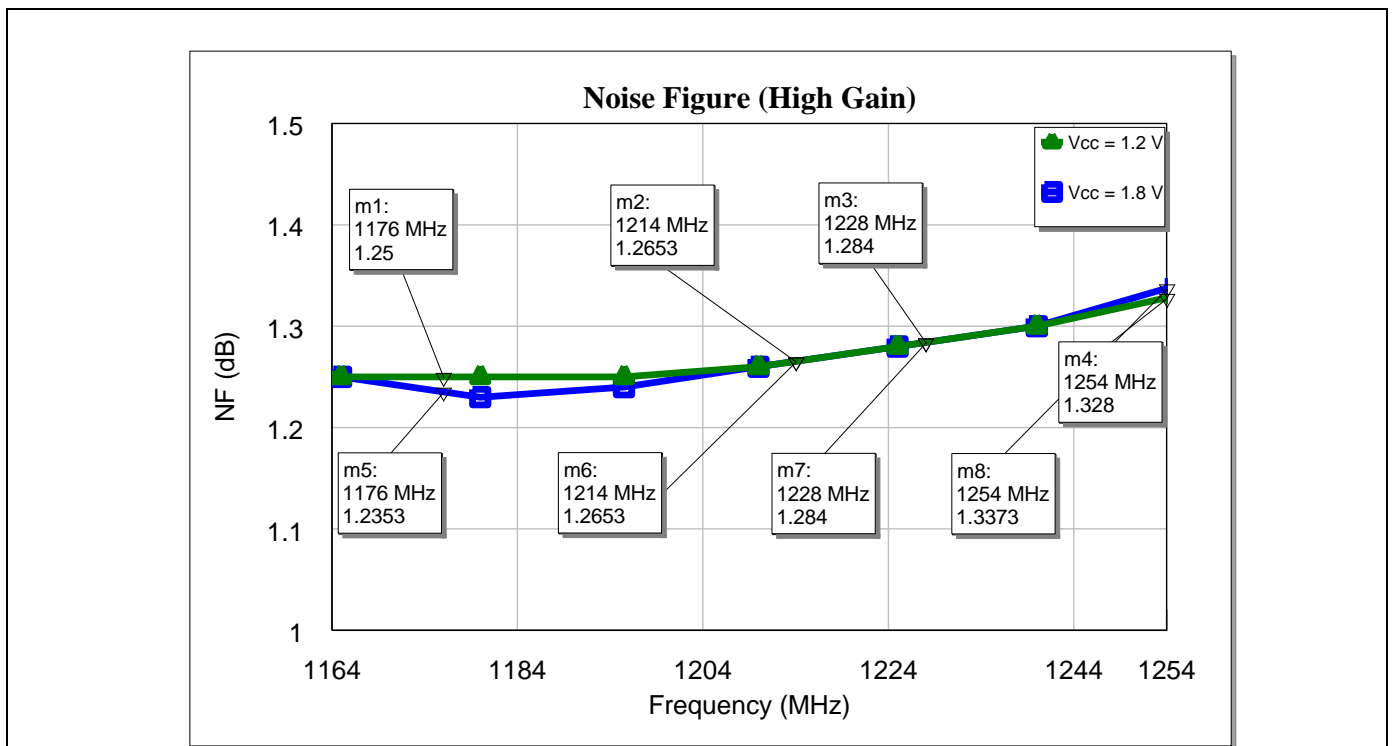


**Figure 7** Insertion power gain (wideband) of BGA123L4 for GNSS applications

**Measurement graphs**

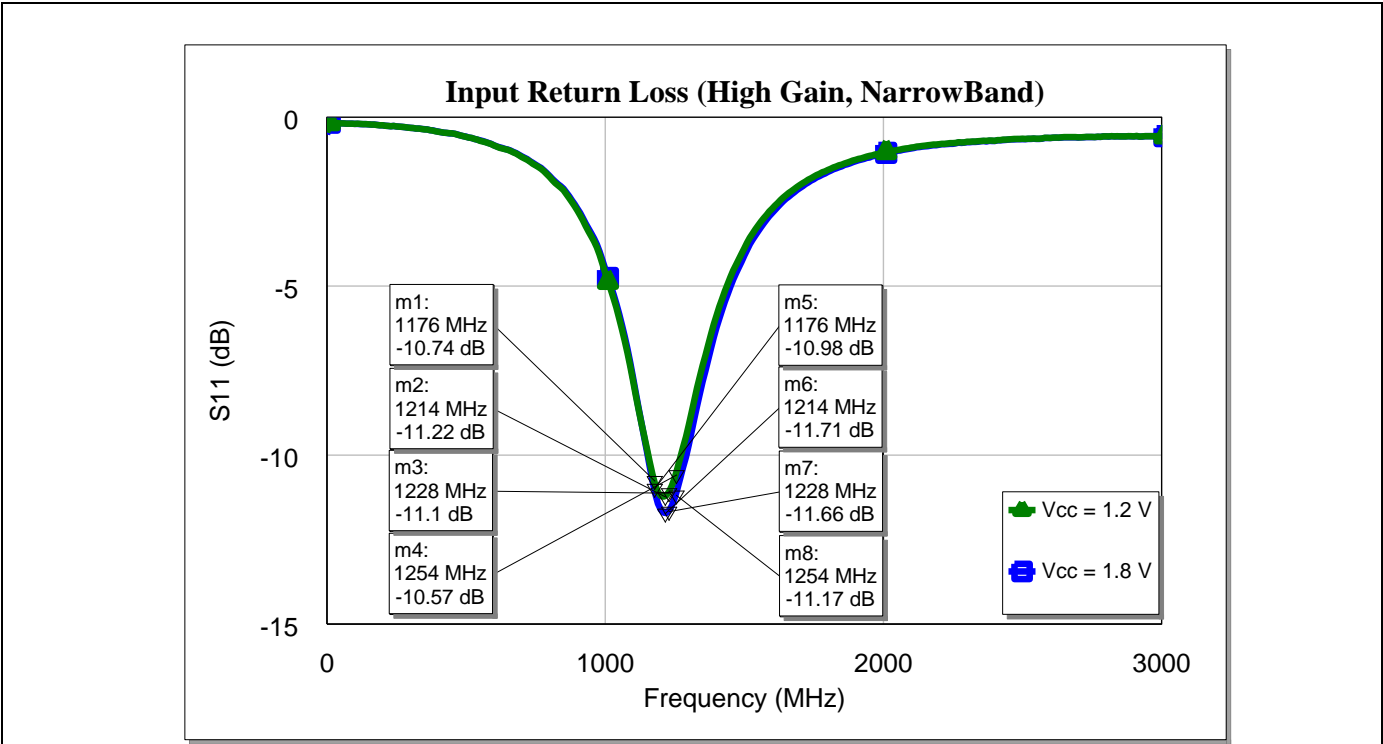


**Figure 8 NF of BGA123L4 for GNSS applications (SMA and connector losses de-embedded, LQW15 inductors for matching)**

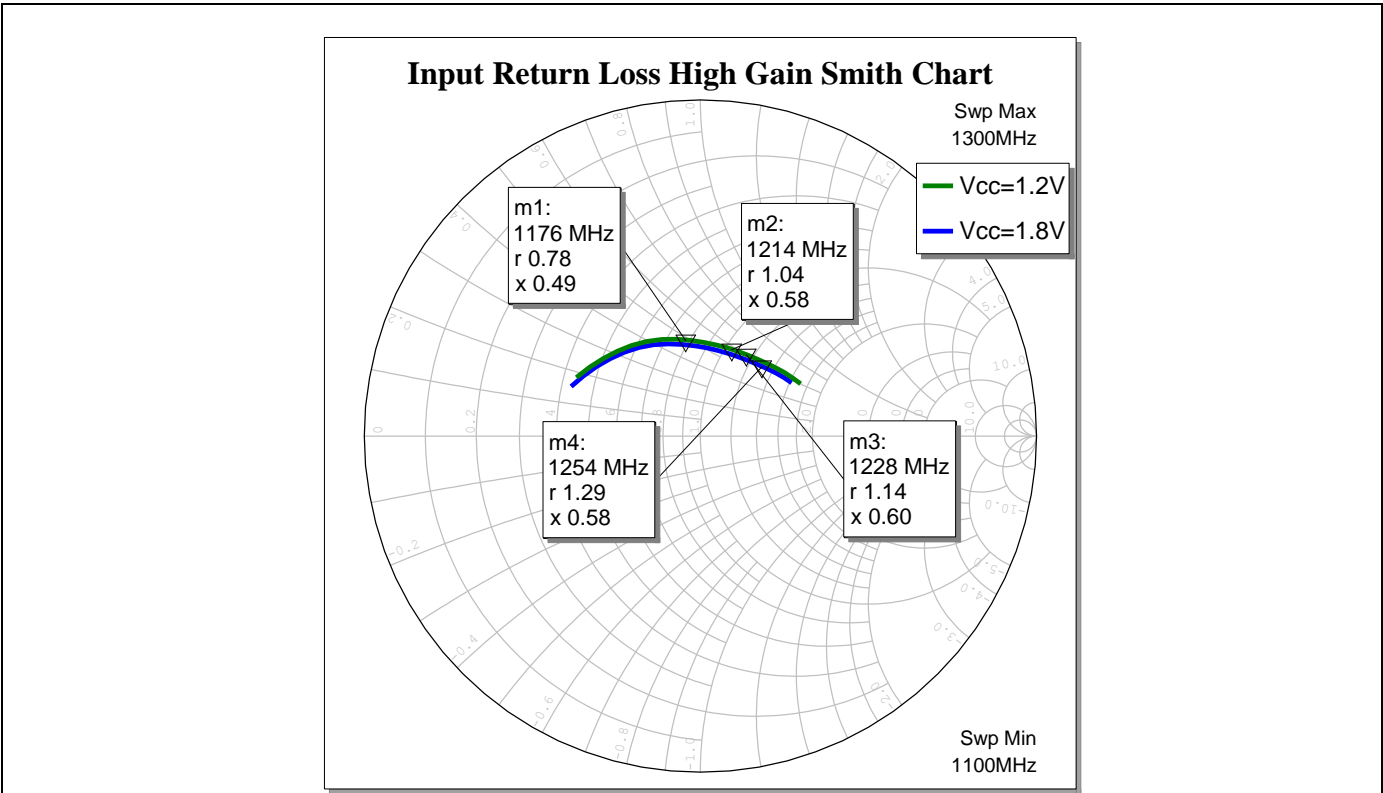


**Figure 9 NF of BGA123L4 for GNSS applications (SMA and connector losses de-embedded, LQP03TN inductors for matching)**

**Measurement graphs**

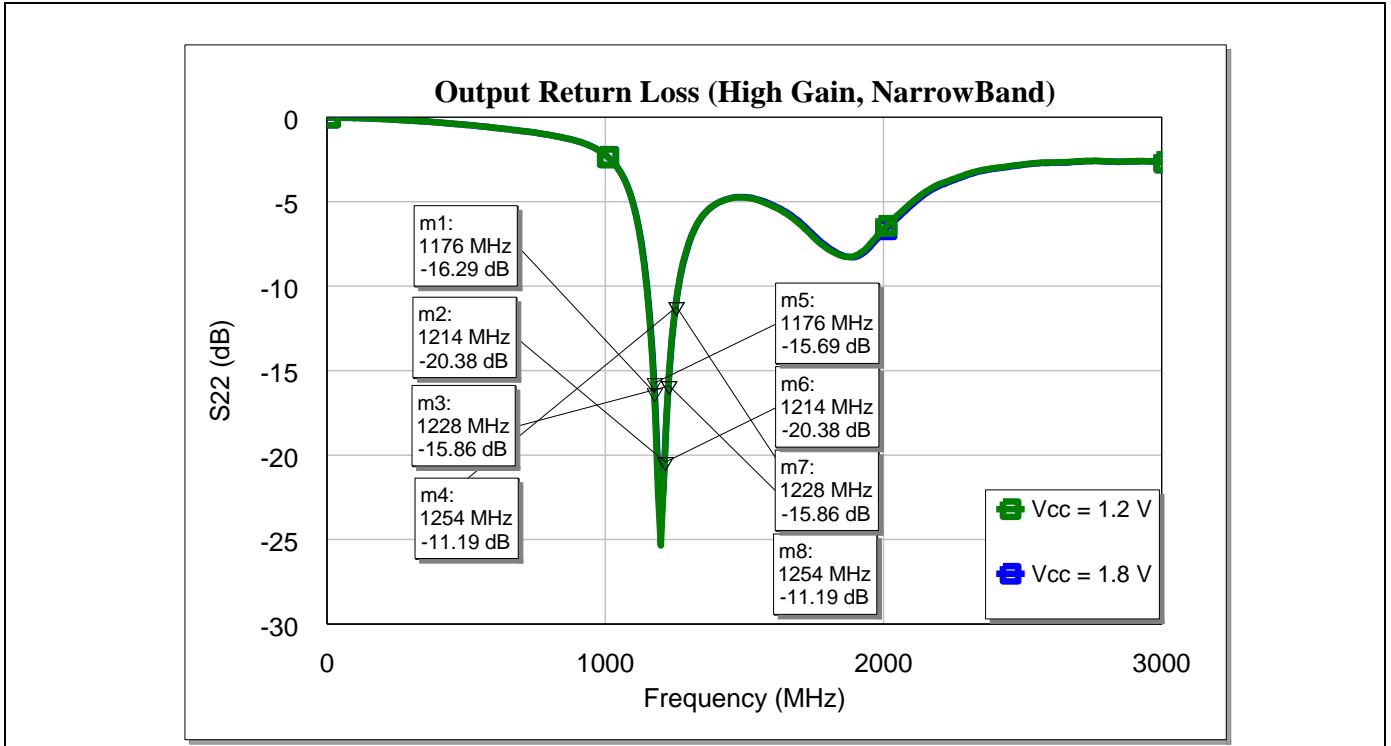


**Figure 10** Input return loss of BGA123L4 for GNSS applications including L2 band (center frequency)

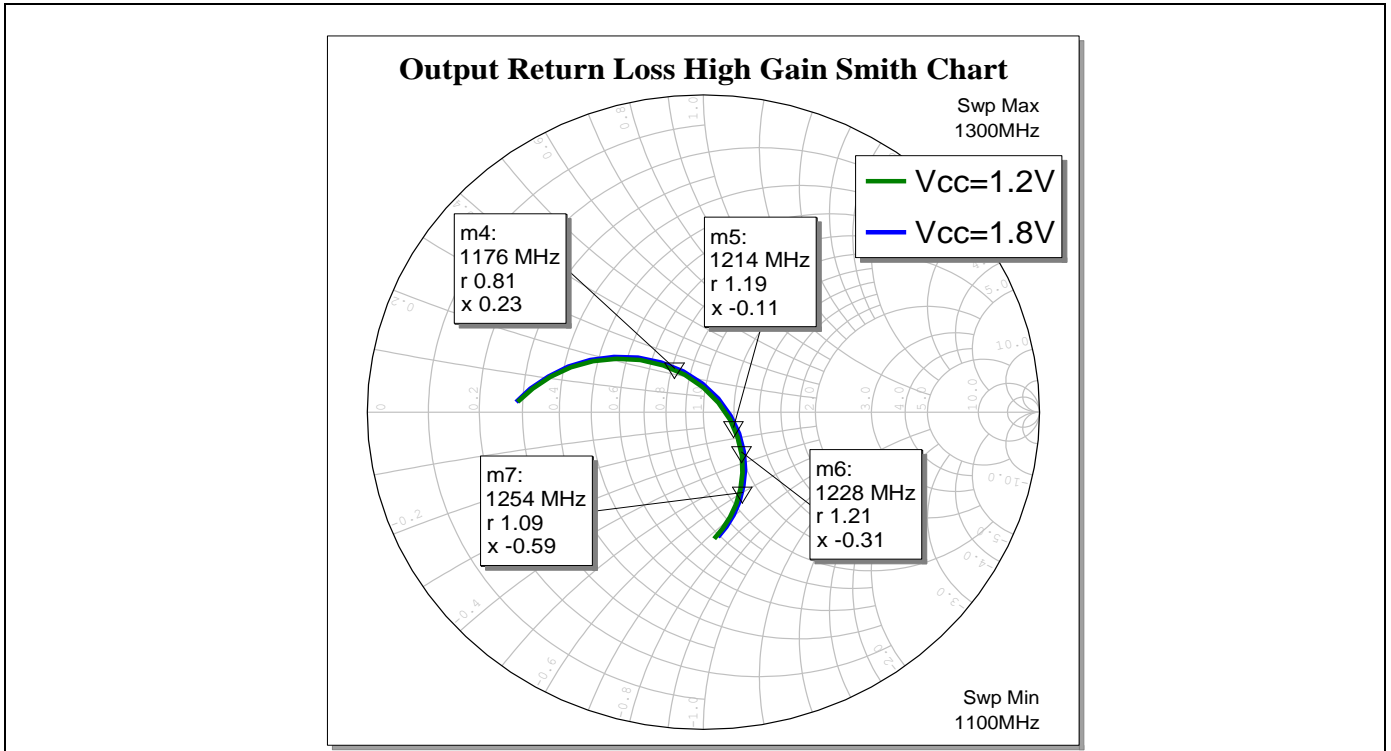


**Figure 11** Input return loss (Smith chart) of BGA123L4 for GNSS applications (port de-embedded)

**Measurement graphs**



**Figure 12 Output return loss of BGA123L4 for GNSS applications**



**Figure 13 Output return loss (Smith chart) of BGA123L4 for GNSS applications (port de-embedded)**



## Measurement graphs

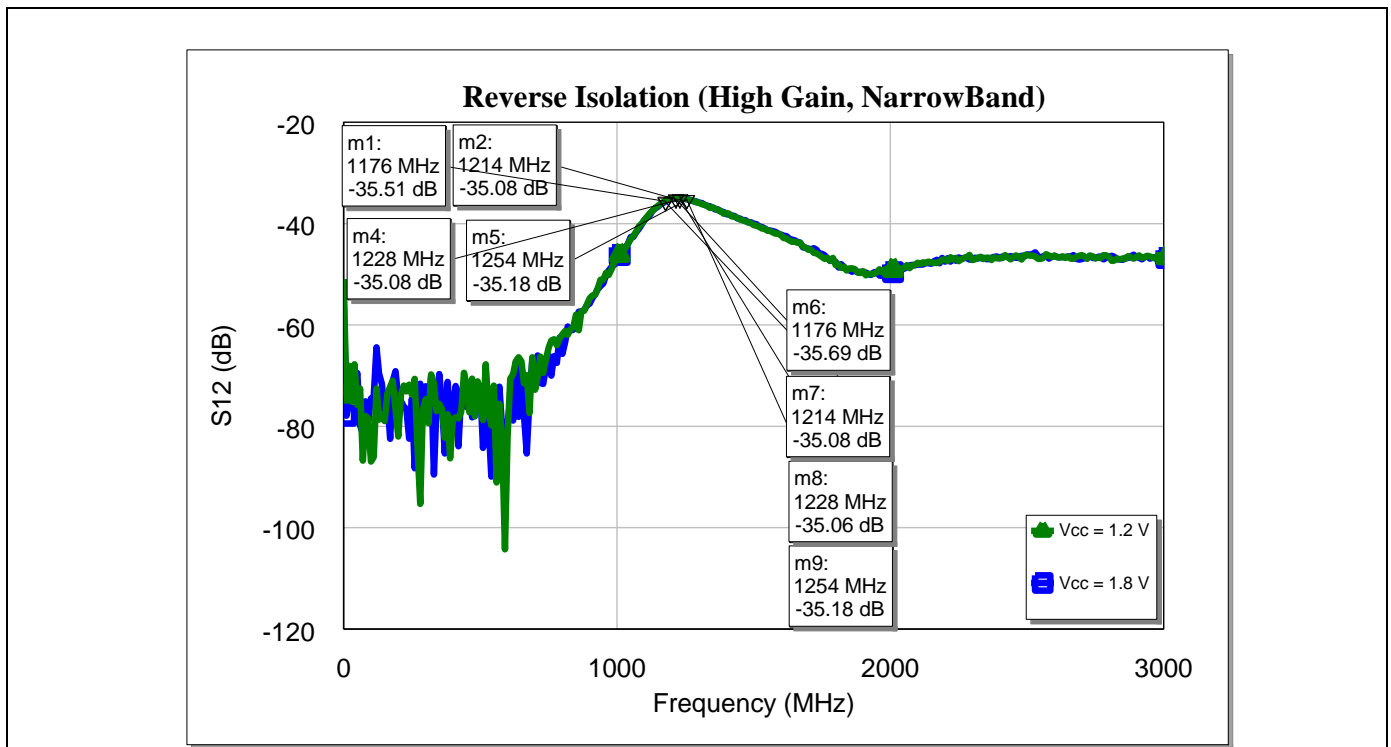


Figure 14 Reverse isolation of BGA123L4 for GNSS applications including L2 band (center frequency)

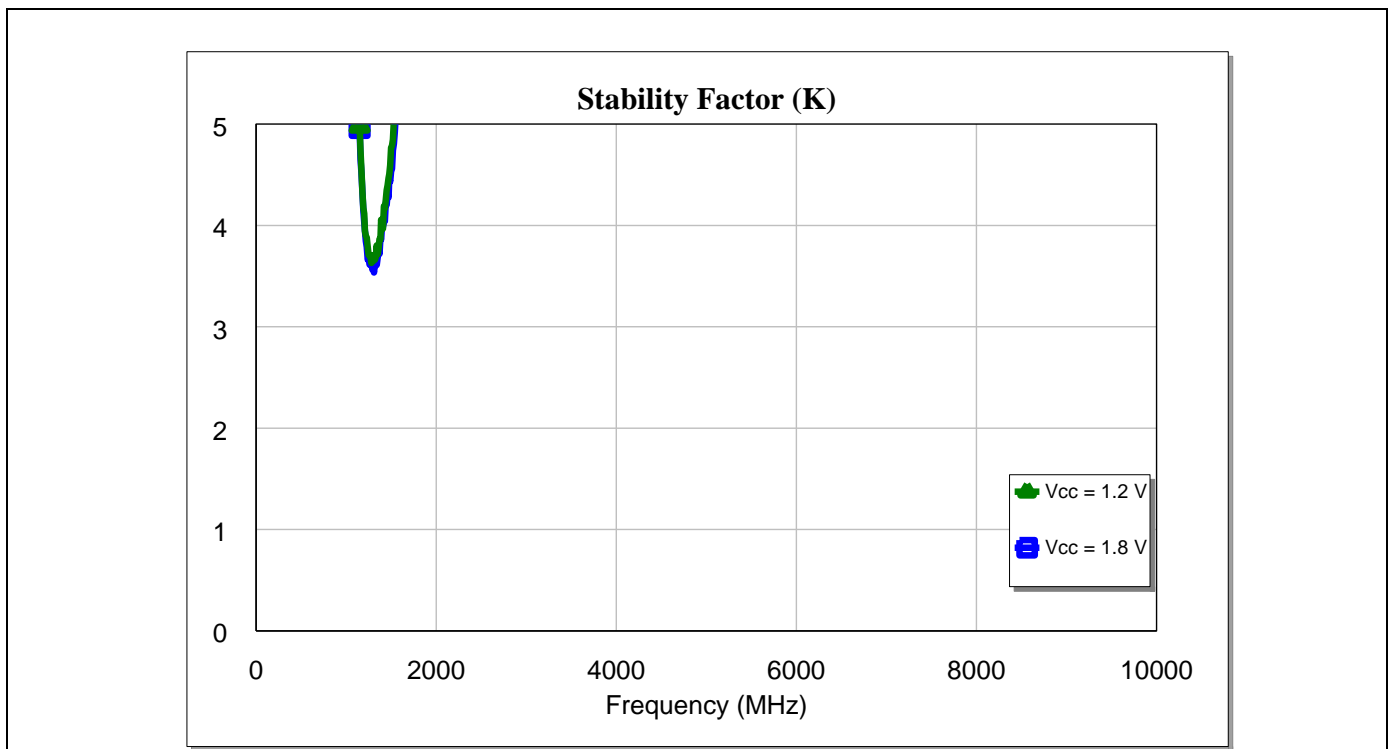
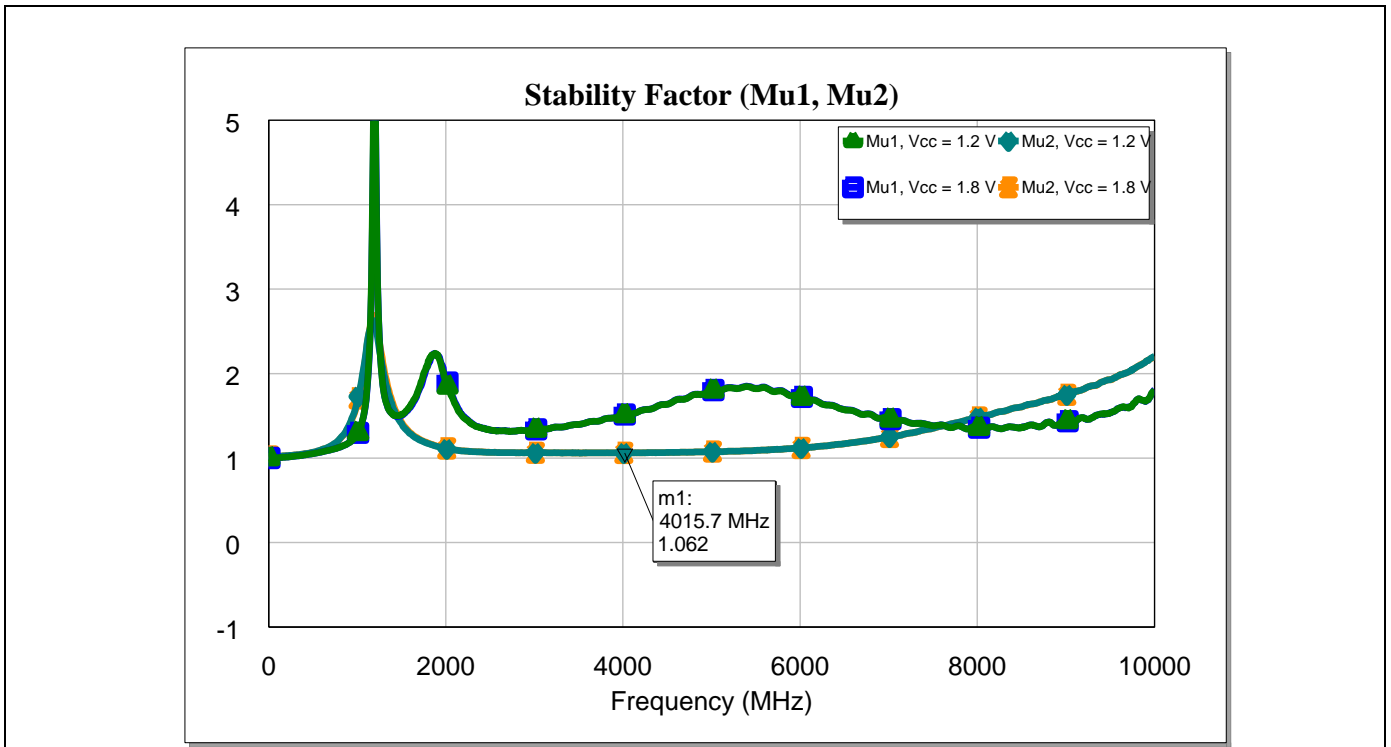
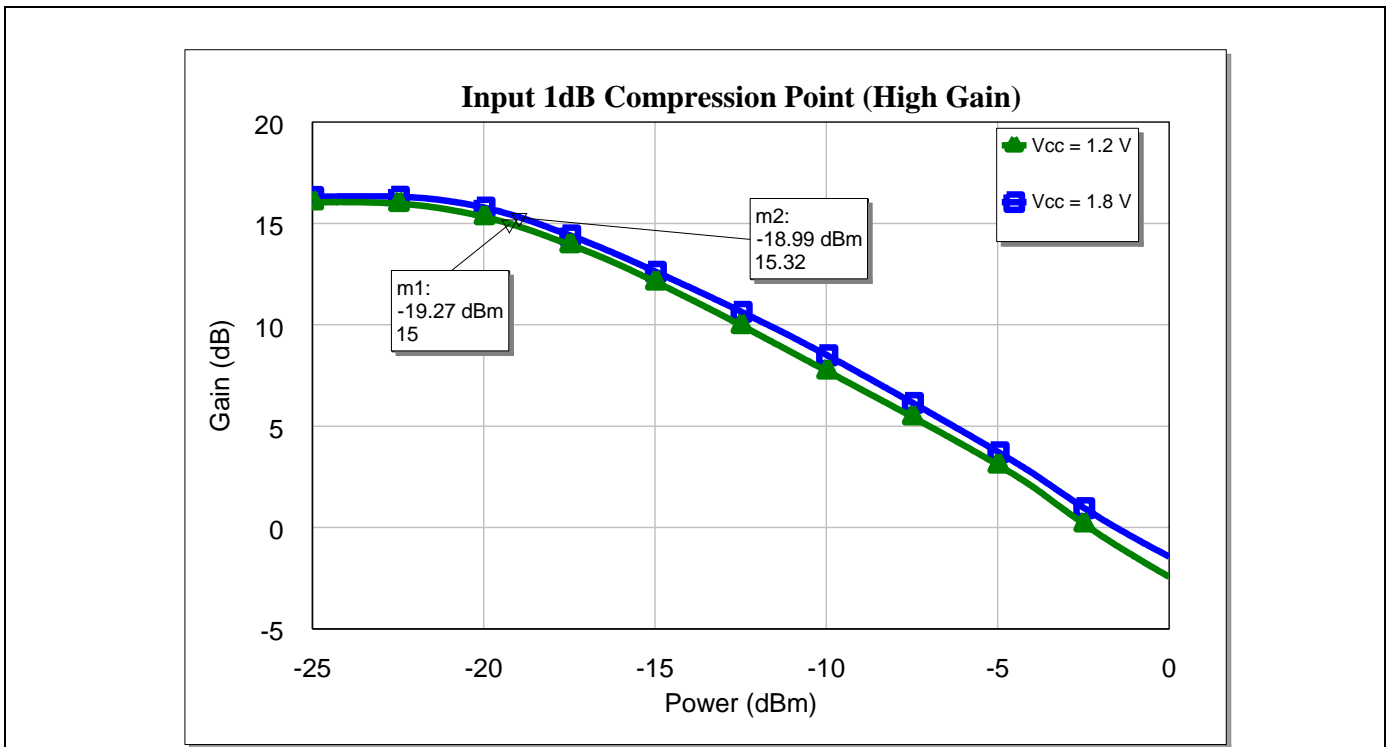


Figure 15 Stability K-factor of BGA123L4 for GNSS applications

**Measurement graphs**

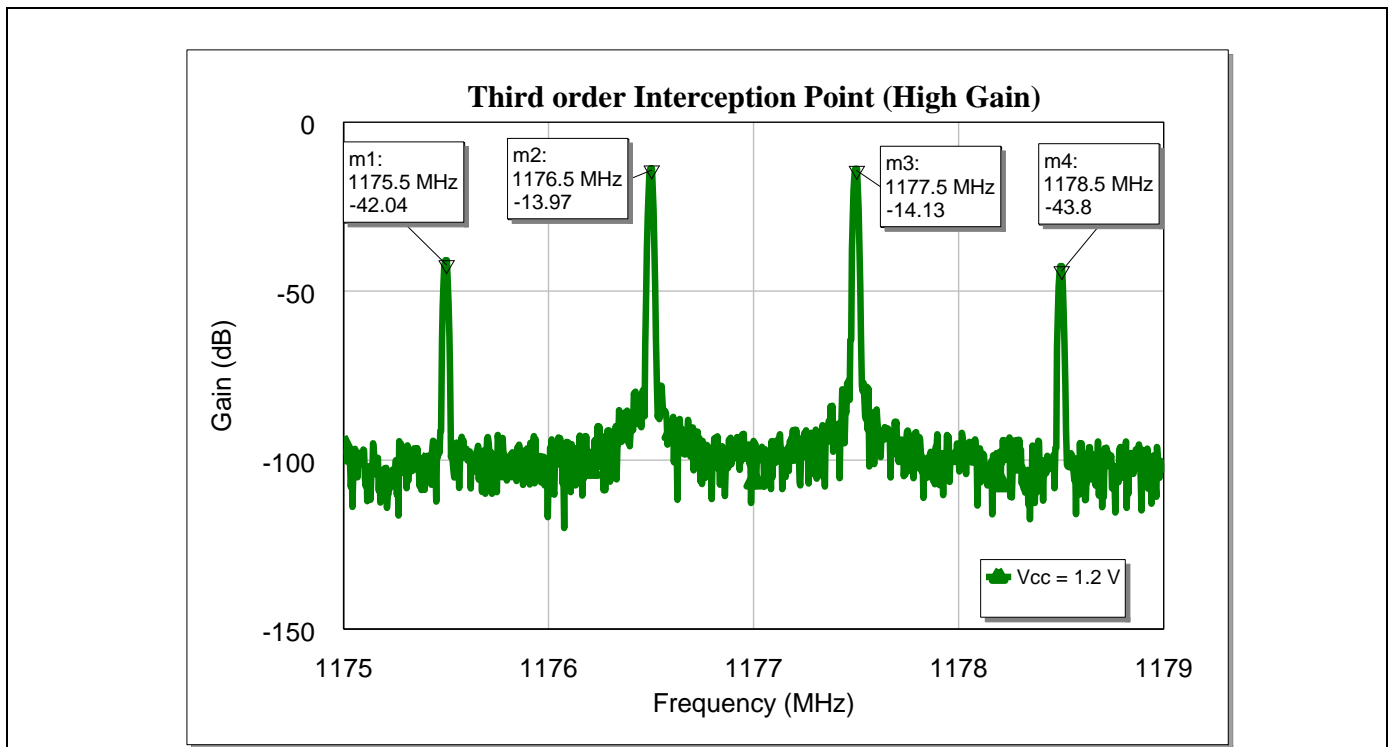


**Figure 16 Stability Mu1-factor, Mu2-factor of BGA123L4 for GNSS applications**

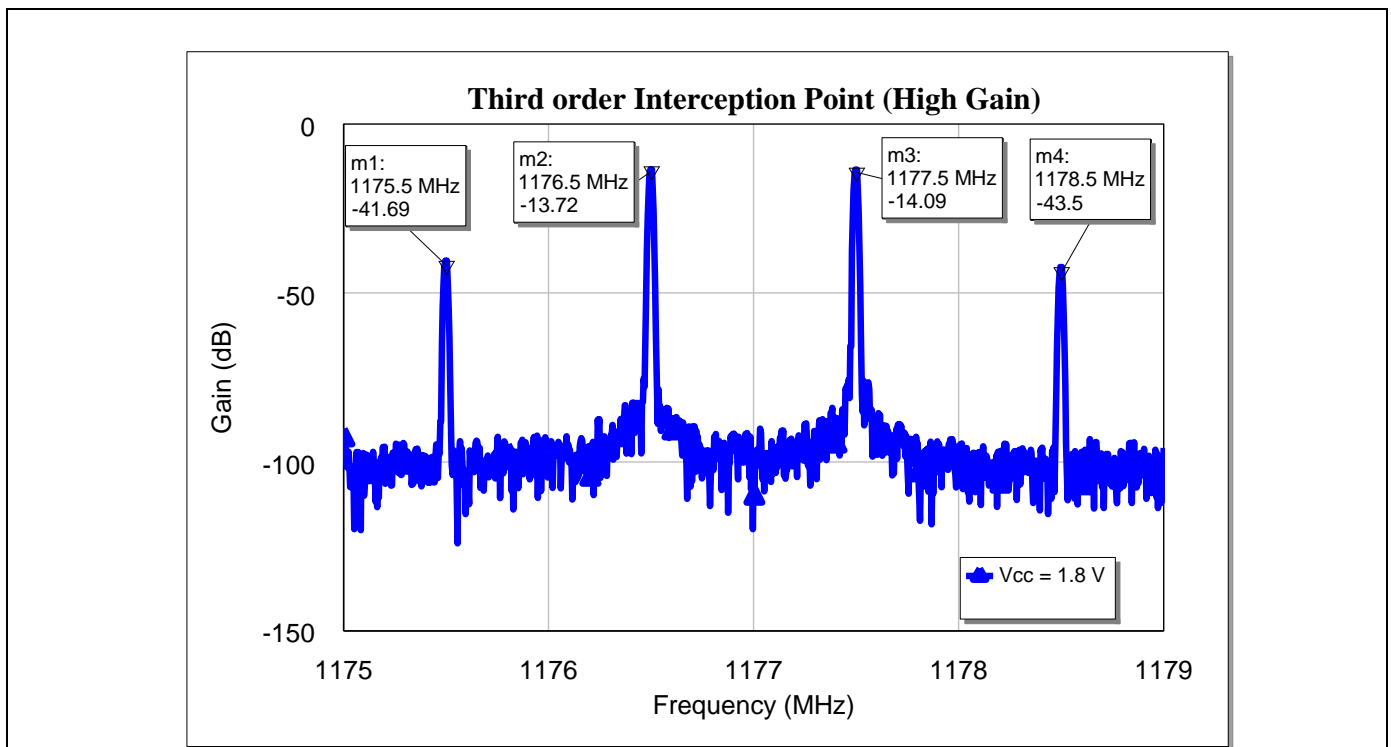


**Figure 17 Input 1 dB compression point of BGA123L4 for GNSS applications at L5 Centre frequency**

**Measurement graphs**

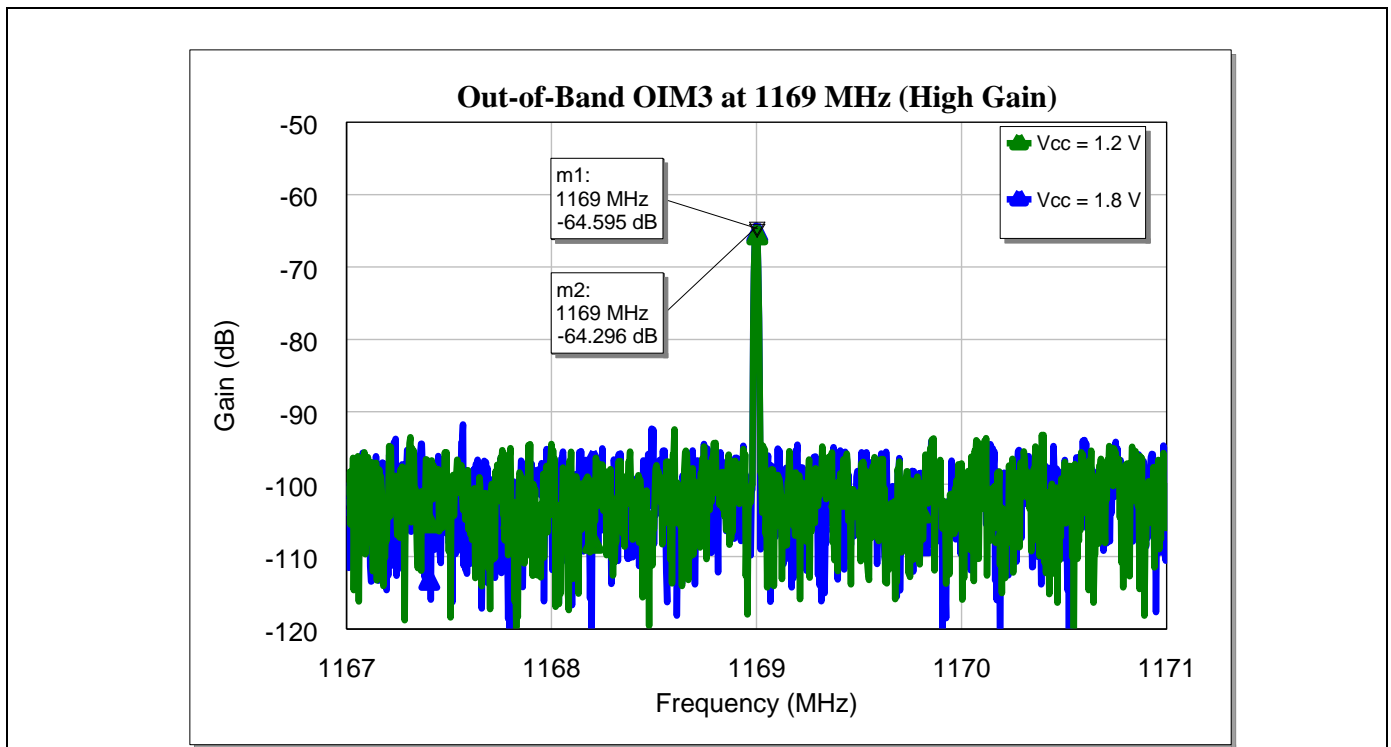


**Figure 18 Third-order interception point (1.2 V) of BGA123L4 for GNSS applications (output referred)**

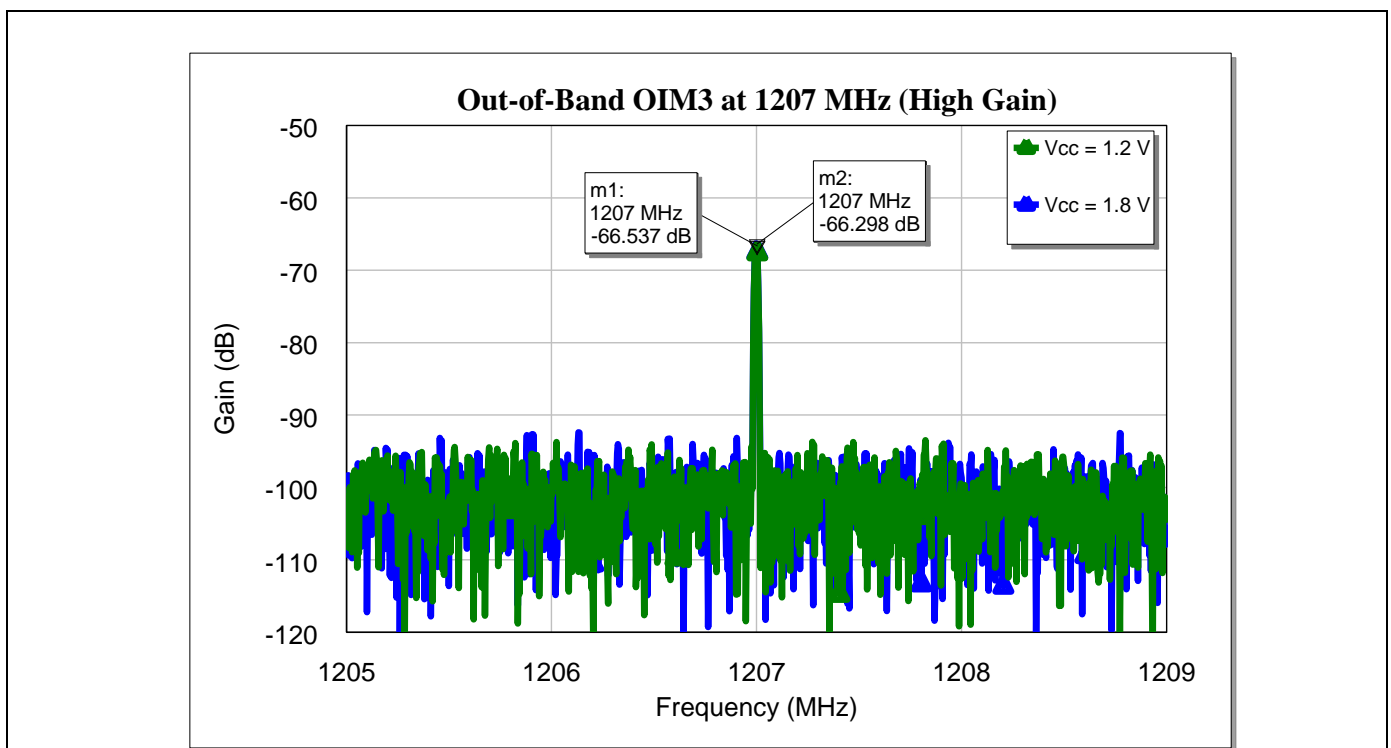


**Figure 19 Third-order interception point (1.8 V) of BGA123L4 for GNSS applications (output referred)**

**Measurement graphs**



**Figure 20 Out-of-band third-order intermodulation point of BGA123L4 for GNSS applications at 1169 MHz (output referred)**



**Figure 21 Out-of-band third-order intermodulation point of BGA123L4 for GNSS applications at 1207 MHz (output referred)**

## Measurement graphs

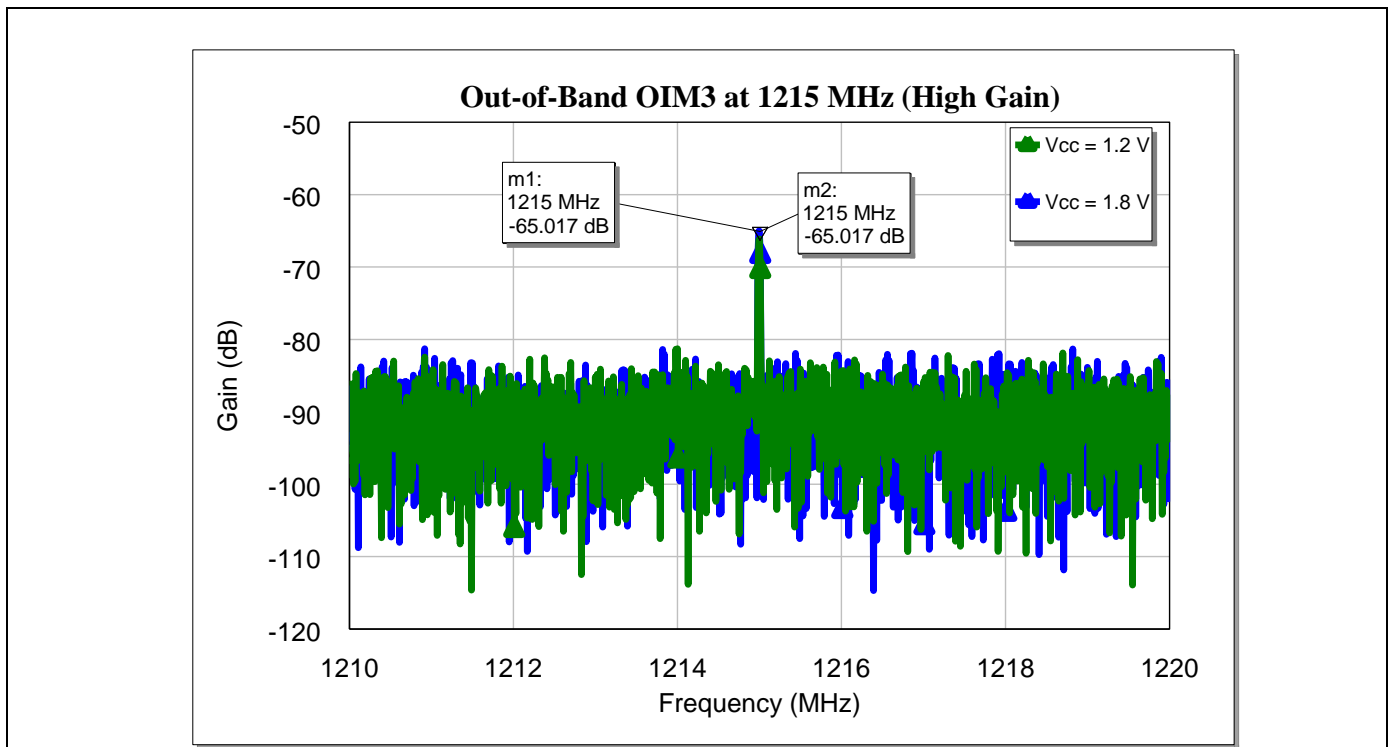


Figure 22 Out-of-band third-order intermodulation point of BGA123L4 for GNSS applications at 1215 MHz (output referred)



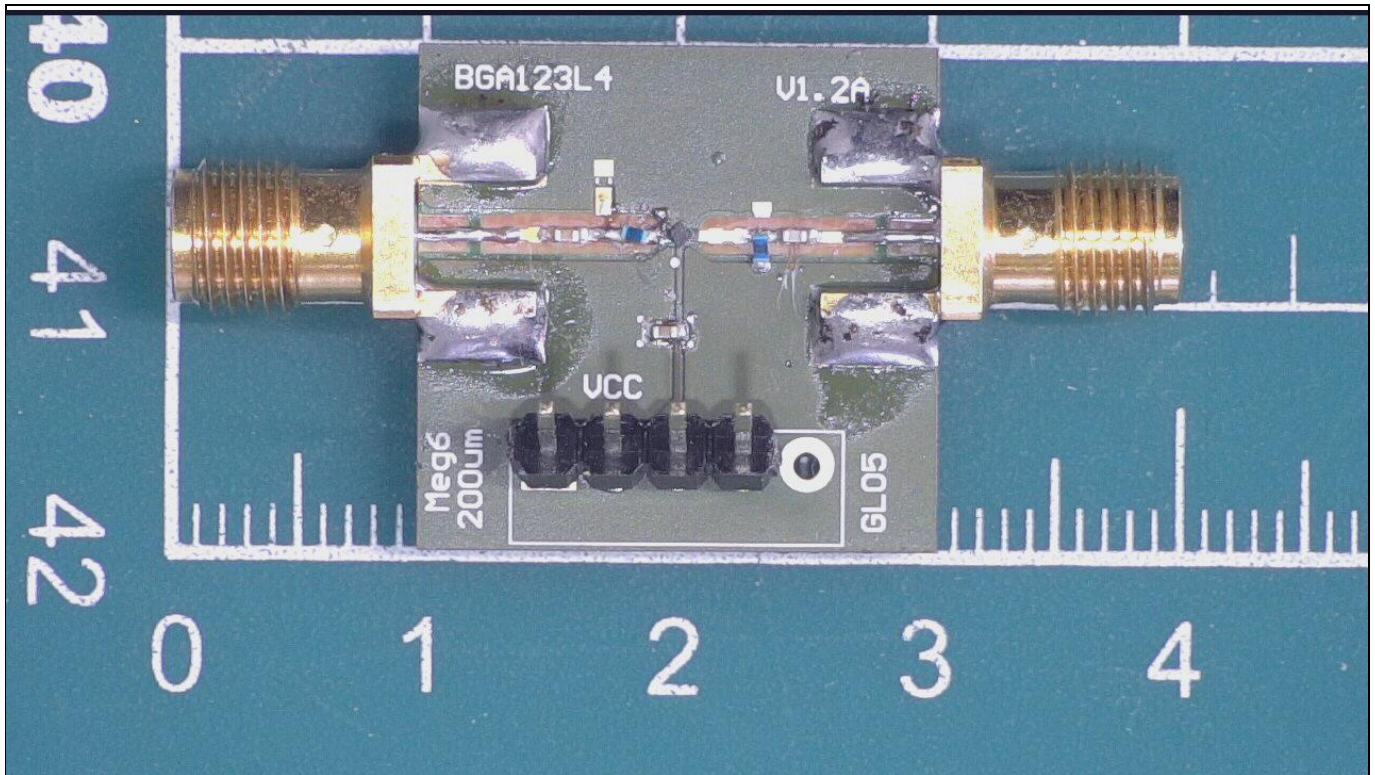
## 5 Evaluation board and layout information

In this application note, the following PCB is used:

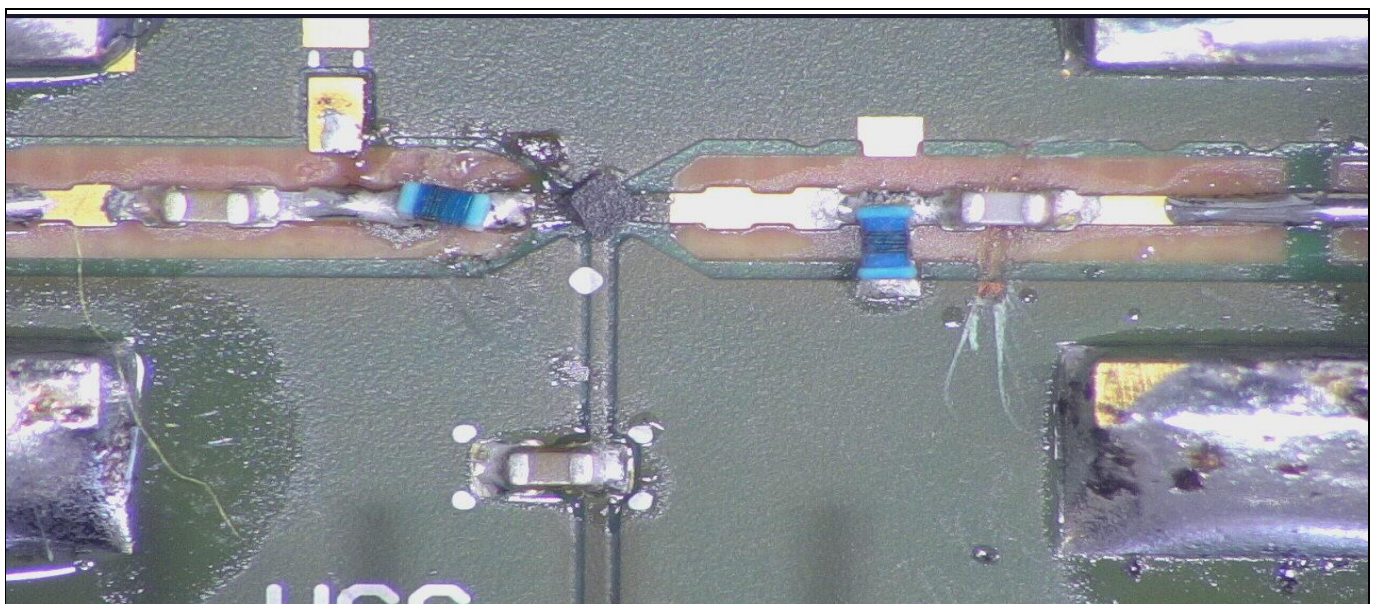
PCB marking: **GL05 V1.2A**

PCB material: **FR 4**

$\epsilon_r$  of PCB material: **4.3**



**Figure 23 Photo of evaluation board (overview)**



**Figure 24 Photo of evaluation board (detailed view)**

# BGA123L4 as Low Current Low Noise Amplifier for GNSS Applications in L5/E5/G3/L2/E2 bands



## Evaluation board and layout information

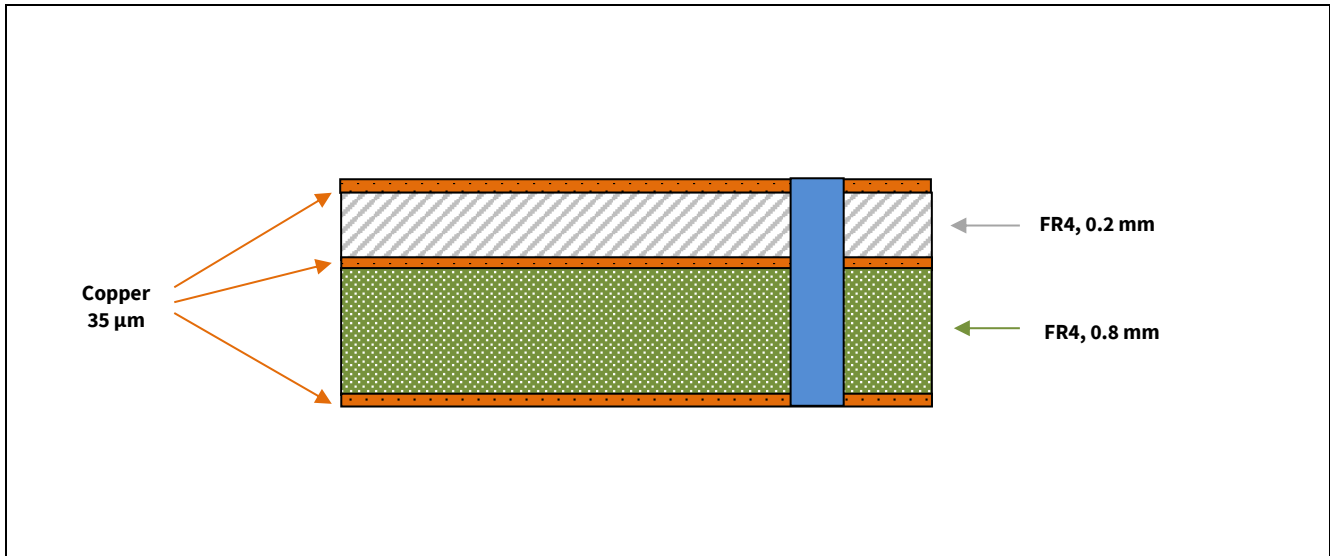


Figure 25 PCB layer information

## **6 Authors**

Xiang Li, Senior Application Engineer of Business Unit “Radio Frequency and Sensors”

Adeel Ahmed, Working Student of Business Unit “Radio Frequency and Sensors”



**References**

## 7 References

- [1] [https://en.wikipedia.org/wiki/GPS\\_signals](https://en.wikipedia.org/wiki/GPS_signals)
- [2] <http://galileognss.eu/wp-content/uploads/2013/09/Galileo-Frequency-bands.jpg>
- [3] [http://www.navipedia.net/index.php/GNSS\\_signal](http://www.navipedia.net/index.php/GNSS_signal)

## Revision history

### Major changes since the last revision

Page or reference	Description of change

#### Trademarks of Infineon Technologies AG

μHVIC™, μIPM™, μPFC™, AU-ConvertIR™, AURIX™, C166™, CanPAK™, CIPOS™, CIPURSE™, CoolDP™, CoolGaN™, COOLiR™, CoolMOS™, CoolSET™, CoolSiC™, DAVE™, DI-POL™, DirectFET™, DrBlade™, EasyPIM™, EconoBRIDGE™, EconoDUAL™, EconoPACK™, EconoPIM™, EiceDRIVER™, eupec™, FCOS™, GaNpowIR™, HEXFET™, HITFET™, HybridPACK™, iMOTION™, IRAM™, ISOFACE™, IsoPACK™, LEDrivIR™, LITIX™, MIPAQ™, ModSTACK™, my-d™, NovalithIC™, OPTIGA™, OptiMOS™, ORIGA™, PowIRaudio™, PowIRstage™, PrimePACK™, PrimeSTACK™, PROFET™, PRO-SIL™, RASIC™, REAL3™, SmartLEWIS™, SOLID FLASH™, SPOC™, StrongIRFET™, SupIRBuck™, TEMPFET™, TRENCHSTOP™, TriCore™, UHVIC™, XHP™, XMC™

Trademarks updated November 2015

#### Other Trademarks

All referenced product or service names and trademarks are the property of their respective owners.

**Edition 2019-07-01**

**Published by**

**Infineon Technologies AG**

**81726 Munich, Germany**

**© 2019 Infineon Technologies AG.**

**All Rights Reserved.**

**Do you have a question about this document?**

**Email: [erratum@infineon.com](mailto:erratum@infineon.com)**

**Document reference**

**AN\_1906\_PL55\_1907\_143443**

#### IMPORTANT NOTICE

The information contained in this application note is given as a hint for the implementation of the product only and shall in no event be regarded as a description or warranty of a certain functionality, condition or quality of the product. Before implementation of the product, the recipient of this application note must verify any function and other technical information given herein in the real application. Infineon Technologies hereby disclaims any and all warranties and liabilities of any kind (including without limitation warranties of non-infringement of intellectual property rights of any third party) with respect to any and all information given in this application note.

The data contained in this document is exclusively intended for technically trained staff. It is the responsibility of customer's technical departments to evaluate the suitability of the product for the intended application and the completeness of the product information given in this document with respect to such application.

For further information on the product, technology, delivery terms and conditions and prices please contact your nearest Infineon Technologies office ([www.infineon.com](http://www.infineon.com)).

#### WARNINGS

Due to technical requirements products may contain dangerous substances. For information on the types in question please contact your nearest Infineon Technologies office.

Except as otherwise explicitly approved by Infineon Technologies in a written document signed by authorized representatives of Infineon Technologies, Infineon Technologies' products may not be used in any applications where a failure of the product or any consequences of the use thereof can reasonably be expected to result in personal injury.