

# GNSS MMIC LNA: BGA524N6

## Low Noise Amplifier for GNSS Applications in 1550 MHz - 1615 MHz with a High Q Inductor for Matching

Application Note AN400

### About this document

#### Scope and purpose

This application note describes Infineon's GNSS MMIC LNA: BGA524N6 as Low Noise Amplifier for Global Navigation Satellite System (1550 MHz – 1615 MHz) applications.

1. This application note investigates the BGA524N6's performance for at 1550 MHz - 1615 MHz using a high quality factor inductor for input matching.
2. The BGA524N6 is a Silicon-Germanium Low Noise Amplifier.
3. The BGA524N6 serves the Global Navigation Satellite System applications such as GPS, GLONASS, Galileo and Beidou.
4. In this application note, the performance parameters are measured for GNSS applications on a MEG6 board. The GNSS related Out-of-band IP3 and LTE Band 13 interference are also presented. The high quality factor inductor brings a Noise Figure improvement of 0.05 dB.
5. Key performance parameters achieved at 2.8V, 1575.42 MHz
  - a. Noise Figure = 0.73 dB
  - b. Gain = 19.6 dB
  - c. Input P1dB = -12.0 dBm
  - d. Input IP3 = -9.1 dBm
  - e. Out-of-band IP3 = -4.5 dBm



## Table of Content

<b>1</b>	<b>Introduction of Global Navigation Satellite Systems (GNSS) Applications.....</b>	<b>4</b>
<b>2</b>	<b>BGA524N6 Overview .....</b>	<b>7</b>
<b>3</b>	<b>Application Circuit and Performance Overview .....</b>	<b>9</b>
<b>4</b>	<b>Measurement Graphs .....</b>	<b>14</b>
<b>5</b>	<b>Evaluation Board and Layout Information .....</b>	<b>23</b>
<b>6</b>	<b>Authors.....</b>	<b>25</b>
<b>7</b>	<b>Reference.....</b>	<b>25</b>

### List of Figures

Figure 1	Application Diagram: Receiver Frontend the Global Navigation Satellite System With LNAs and Filter .....	4
Figure 1	Measurement setup for LTE Band 13 second harmonic .....	5
Figure 2	BGA524N6 in TSNP-6-1.....	7
Figure 3	Package and pin connections of BGA524N6.....	8
Figure 4	Schematics of the BGA524N6 Application Circuit .....	13
Figure 5	Narrowband Gain of the BGA524N6 as LNA for GNSS applications .....	14
Figure 6	Wideband Gain of BGA524N6 as LNA for GNSS applications.....	14
Figure 7	Noise Figure of BGA524N6 as LNA for GNSS applications.....	15
Figure 8	Input matching of BGA524N6 as LNA for GNSS applications.....	15
Figure 9	Input matching (Smith chart) of BGA524N6 as LNA for GNSS applications .....	16
Figure 10	Output matching of the BGA524N6 as LNA for GNSS applications.....	16
Figure 11	Output matching (Smith chart) of BGA524N6 as LNA for GNSS applications .....	17
Figure 12	Isolation of BGA524N6 as LNA for GNSS applications.....	17
Figure 13	Stability factor k of BGA524N6 as LNA for GNSS applications.....	18
Figure 14	Stability factors $\mu_1$ , $\mu_2$ of the BGA524N6 as LNA for GNSS applications.....	18
Figure 15	IP1dB of the BGA524N6 as LNA for GNSS applications (1.8V) .....	19
Figure 16	IP1dB of the BGA524N6 as LNA for GNSS applications (2.8V) .....	19
Figure 17	Output IP3 of the BGA524N6 as LNA for GNSS applications (1.8V) .....	20
Figure 18	Output IP3 of the BGA524N6 as LNA for GNSS applications (2.8V) .....	20
Figure 19	Out-of-band IP3 of the BGA524N6 as LNA for GNSS applications (1.8V) .....	21
Figure 20	Out-of-band IP3 of the BGA524N6 as LNA for GNSS applications (2.8V) .....	21
Figure 21	LTE Band 13 Second Harmonic Interference of the BGA524N6 as LNA for GNSS applications (LNA output referred) .....	22
Figure 22	Out-of-band Second Harmonic of the BGA524N6 as LNA for GNSS applications (LNA output referred), $f_{1in} = 824\text{MHz} - 30\text{dBm}$ , $f_{2in} = 2400\text{MHz} - 30\text{ dBm}$ .....	22
Figure 23	Photo Picture of Evaluation Board (overview) .....	23
Figure 24	Photo Picture of Evaluation Board (detailed view).....	23
Figure 25	PCB Layer Information .....	24

### List of Tables

Table 1	Pin Assignment of BGA524N6 .....	8
Table 2	Mode Selection of BGA524N6 .....	8
Table 3	Electrical Characteristics (at room temperature) at $V_{cc} = 1.8\text{V}$ .....	9
Table 4	Electrical Characteristics (at room temperature) at $V_{cc} = 2.8\text{V}$ .....	11
Table 5	Bill-of-Materials .....	13

1) The graphs are generated with the simulation program AWR Microwave Office®.

# 1 Introduction of Global Navigation Satellite Systems (GNSS) Applications

Global Navigation Satellite Systems (GNSS) are among the fastest growing businesses in the electronic industry. Today, GNSS is much more than the well-known GPS, which was introduced for civilian use more than a decade ago. Nations around the world are working on their own navigation satellite systems for strategic reasons and also to offer improved user experience. Today, three GNSS systems are operational: the United States GPS, the Russian GLONASS and the Chinese Beidou. The Galileo positioning system being developed by the European Union is expected to be functional by 2014.

From a civilian usage point, additional systems added to GNSS bring with them the advantages of increased satellite signal reception, increased coverage, higher precision and the facility for additional features such as Search And Rescue (SAR). The most important market segments since 2008 are Personal Navigation Devices (PND) and GNSS enabled mobile phones. The architecture and the performance of the so-called RF front-end is the key contributor to fulfill the strict requirements of the GNSS system, because it consists of the whole line-up between the GNSS antenna and the integrated GNSS chipset. The main challenges for the growing GNSS-enabled mobile phone market are to achieve high sensitivity and high immunity against interference of cellular signals driven by government regulations for safety and emergency reasons, for example, in the US and Japan. This means the reception for GPS/GLONASS signals at very low power levels down to less than -160 dBm in mobile phones in the vicinity of co-existing high power cellular signals. In addition, excellent ESD robustness characteristics and low power consumption for long battery usage duration are mandatory features for portable and mobile phones. Below is an application diagram of the GNSS RF front-end.

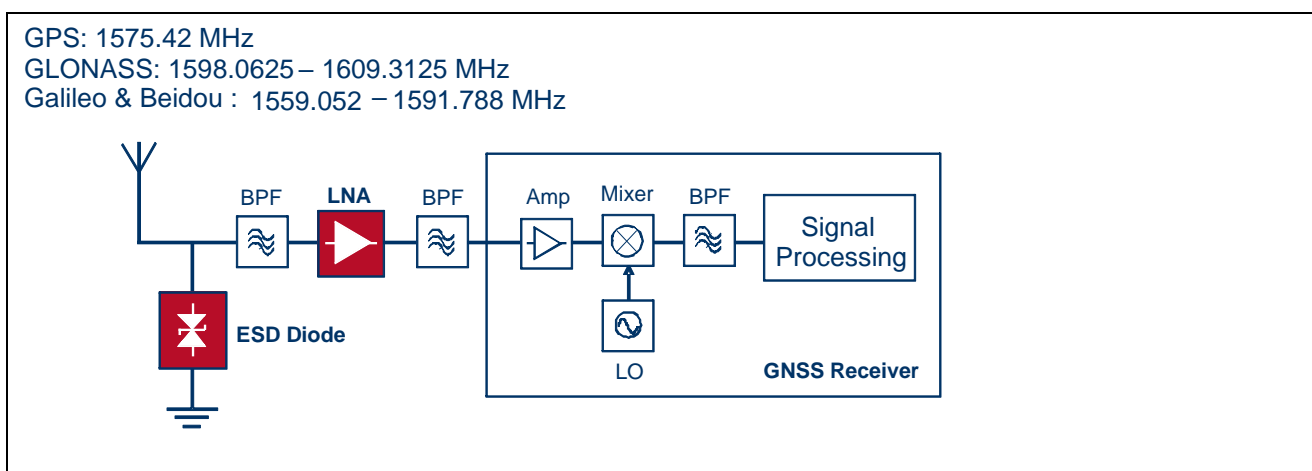

**Figure 1 Application Diagram: Receiver Frontend the Global Navigation Satellite System With LNAs and Filter**

A major interference signal at the GNSS frequency band is the presence of LTE band 13 second harmonics. For example, a jammer signal from 787 MHz will generate a second harmonic signal at 1574 MHz, and thus add interference to the wanted GNSS signal. In this application note, we measure the influence of LTE band 13 second harmonic with below setup. The bandpass filter before the Device-under-test (DUT) is intended to let through the Band 13 signal, and to filter out the second harmonic generated by the signal generator. The attenuator is used to improve the mismatch at the B13 frequency. The bandpass filter after the Device-under-test is intended to let through the GNSS signal while filtering out the B13 frequency from the DUT output. The attenuator is used to improve the mismatch at the B13 frequency. In below application note, the losses from BPF2 and Attenuator 2 after DUT have been compensated, when measuring the B13 H2out for Table 3 and Table 4.

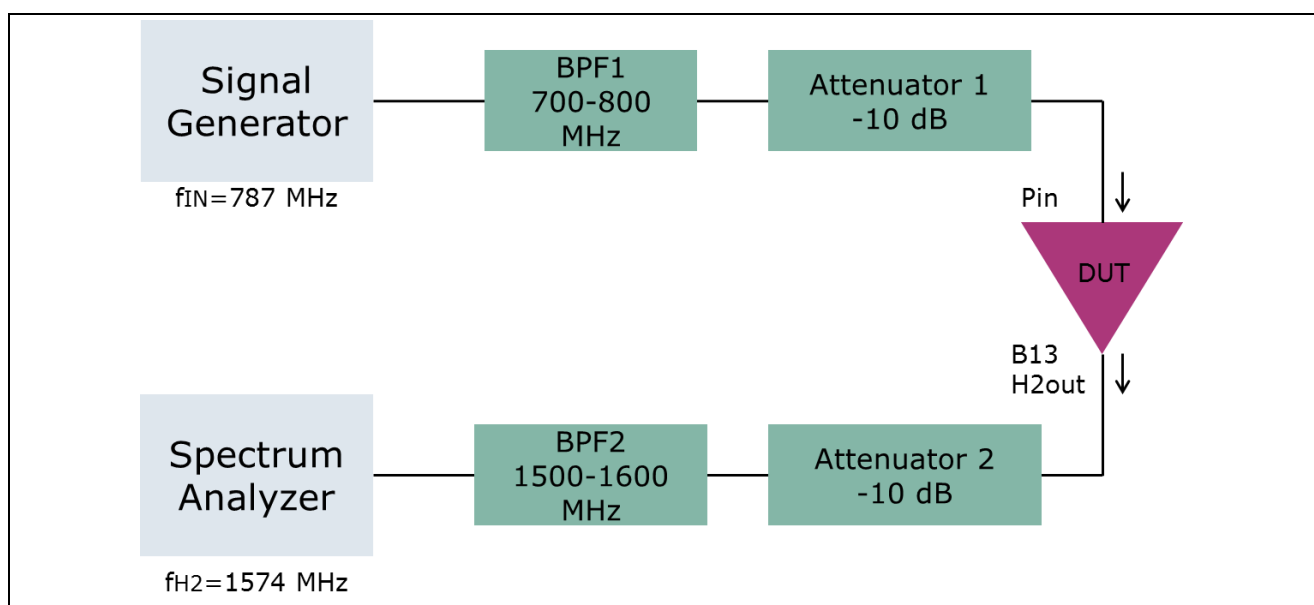

**Figure 1 Measurement setup for LTE Band 13 second harmonic**

For more information on the GNSS system and its system challenges, please visit the application guide for mobile communication at [www.infineon.com](http://www.infineon.com) [1].

### 1.1 Infineon's Product Portfolio for the GNSS Applications

Infineon Technologies is the market leader in GNSS LNAs for navigation applications in PND and cellular products. Infineon Technologies offers a complete product portfolio to all customers designing high performance flexible RF front-end solutions for GNSS:



- **Low Noise Amplifiers (LNA):** consisting of a wide range of products like high performance MMICs as well as cost effective and high end RF transistors
- **Front-End Module (FEM):** Infineon offers the world's smallest GPS/GLONASS FEMs with LNAs and band-pass filter(s) integrated into a single tiny package with well-optimized performance for navigation in mobile phones
- **Transient Voltage Suppression (TVS) Diodes:** protecting GNSS antenna reliably up to 20 kV

For more information on Infineon's available product portfolio for the GNSS application, please visit Infineon's website at [www.infineon.com](http://www.infineon.com).

### 1.2 Key Features of Low Noise Amplifiers (LNAs)

**Low Noise Figure & High Gain:** The power levels of satellite signals received by a GPS/GNSS receiver are as low as -160 dBm. This poses a challenge on the sensitivity of the system. An external LNA with low noise figure and high gain is required to boost the sensitivity of the system and Time-To-First Fix (TTFF).

**High Linearity:** In modern mobile phones, the GNSS signals are co-habited by strong interfering cellular signals. The cellular signals can mix to produce Intermodulation products exactly in the GNSS receiver frequency band. To enhance interference immunity of the GNSS systems, LNAs with high linearity characteristics such as input IP3 and input P1dB are required.

**Low Current Consumption:** Power consumption is an important feature in GNSS devices which are mainly battery operated mobile devices. Infineon's LNAs have an integrated power on/off feature which provides for low power consumption and increased stand-by time for GNSS handsets. Moreover, the low current consumption (down to 2.5 mA) makes Infineon's LNAs suitable for portable technology like GNSS receivers and mobile phones.

## 2 BGA524N6 Overview

### 2.1 Features

- High insertion power gain: 19.6 dB
  - Out-of-band input 3rd order intercept point: -4 dBm
  - Input 1 dB compression point: -12 dBm
  - Low noise figure: 0.55 dB
  - Low current consumption: 2.5 mA
  - Operating frequencies: 1550 - 1615 MHz
  - Supply voltage: 1.5 V to 3.3 V
  - Digital on/off switch (1 V logic high level)
  - Ultra small TSNP-6-2 leadless package (footprint: 0.7 x 1.1 mm<sup>2</sup>)
  - B7HF Silicon Germanium technology
  - RF output internally matched to 50
  - Only 1 external SMD component necessary
- 2 kV HBM ESD protection (including AI-pin)
  - Pb-free (RoHS compliant) package

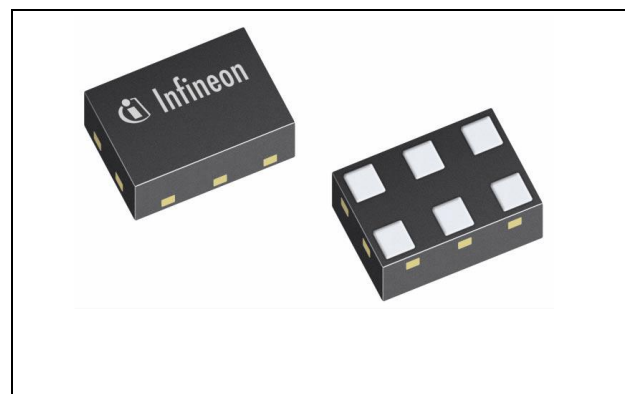

Figure 2 BGA524N6 in TSNP-6-1



### 2.2 Key Applications of BGA524N6

- Ideal for all Global Navigation Satellite Systems (GNSS) applications like
  - GPS (US GNSS) working in the L1 band at 1575.42 MHz
  - GLONASS (Russian GNSS) working in the L1 band from 1598.0625 MHz to 1605.3125 MHz
  - Galileo (European GNSS) working in the E1 band from 1559.052 MHz to 1591.788 MHz
  - Beidou (Chinese GNSS) working in E2 band at 1561.098 MHz

### 2.3 Description

The BGA524N6 is a front-end low noise amplifier for Global Navigation Satellite Systems (GNSS) from 1550 MHz to 1615 MHz like GPS, GLONASS, Galileo, Beidou and others. The LNA provides 19.6 dB gain and 0.55 dB noise figure at a current consumption of 2.5 mA only in the application configuration described in **Chapter 3**. The BGA524N6 is based upon Infineon Technologies B7HF Silicon Germanium technology. It operates from 1.5 V to 3.3 V supply voltage.

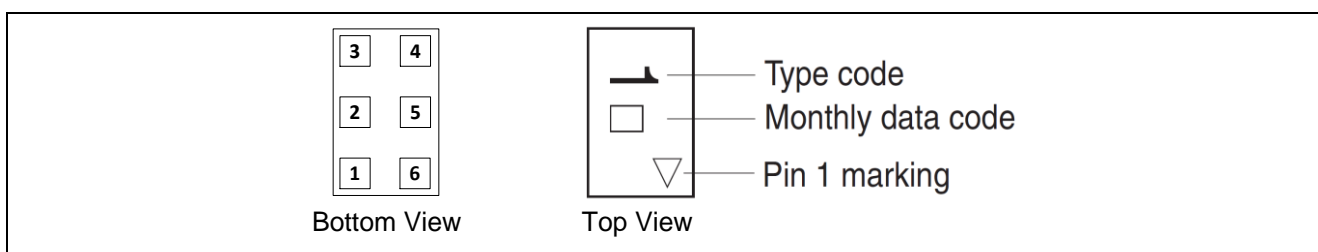

**Figure 3** Package and pin connections of BGA524N6

**Table 1** Pin Assignment of BGA524N6

Pin No.	Symbol	Function
1	GND	Ground
2	VCC	DC supply
3	AO	LNA output
4	GND	Ground
5	AI	LNA input
6	PON	Power on control

**Table 2** Mode Selection of BGA524N6

LNA Mode	Symbol	ON/OFF Control Voltage at PON pin	
		Min	Max
ON	PON, on	1.0 V	VCC
OFF	PON, off	0 V	0.4 V

Please visit the product page of **BGA524N6** ([Link](#)) for more information.



### 3 Application Circuit and Performance Overview

In this chapter the performance of the application circuit, the schematic and bill-on-materials are presented.

**Device:** BGA524N6  
**Application:** Low Noise Amplifier for GNSS applications with a high Q inductor for matching  
**PCB Marking:** BGAXXN6 V2.0  
**EVB Order No.:** AN400

#### 3.1 Summary of Measurement Results

The performance of BGA524N6 for GNSS applications are summarized in the following table.

**Table 3 Electrical Characteristics (at room temperature) at Vcc =1.8V**

Parameter	Symbol	Value			Unit	Comment/Test Condition
DC Voltage	Vcc	1.8			V	V <sub>PON</sub> = V <sub>CC</sub>
DC Current	Icc	2.7			mA	
Navigation System	Sys	Beidou	GPS Galileo	GLONASS		
Frequency Range	Freq	1559 - 1563	1575.42 1559-1591	1598-1609	MHz	Beidou: 1561.098MHz GPS / Galileo: 1575.42MHz GLONASS: 1602 MHz
Gain	G	19.6	19.5	19.4	dB	
Noise Figure	NF	0.74	0.74	0.75	dB	Loss of input line of 0.07 dB is deembedded
Input Return Loss	RLin	11.1	11.3	11.5	dB	
Output Return Loss	RLout	17.0	20.8	25.4	dB	
Reverse Isolation	IRev	37.0	37.1	37.1	dB	
Input P1dB	IP1dB	-15.4	-15.6	-15.9	dBm	
Output P1dB	OP1dB	3.2	2.9	2.5	dBm	
Input IP3	IIP3	-9.7	-9.6	-9.1	dBm	f <sub>1Beidou</sub> = 1561.098 MHz, f <sub>2Beidou</sub> = 1562.098 MHz; f <sub>1GPS/Galileo</sub> = 1575.42 MHz, f <sub>2GPS/Galileo</sub> = 1576.42 MHz; f <sub>1GLONASS</sub> = 1602 MHz, f <sub>2GLONASS</sub> = 1603 MHz; Pin = -30 dBm
Out-of-band IP3 (Input referred)	Oob_IIP3	-5.9			dBm	f1 = 1712.7 MHz; f2 = 1850 MHz, Pin = -20dBm



**Table 3 Electrical Characteristics (at room temperature) at Vcc =1.8V**

Parameter	Symbol	Value	Unit	Comment/Test Condition
Out-of-band IM3 (Output referred)	Oob_OIM3	-28.8	dBm	Measure at 1575.4 MHz
LTE band-13 2 <sup>nd</sup> Harmonic (Input referred)	B13 H2in	-41.8	dBm	
LTE band-13 2 <sup>nd</sup> Harmonic (Output referred)	B13 H2out	-22.3	dBm	f <sub>IN</sub> = 787.7 MHz, P <sub>IN</sub> = -25 dBm; f <sub>H2</sub> = 1575.4 MHz
Out-of-band IM2 (Input referred)	OoB_IIM2	-50.8	dBm	
Out-of-band IM2 (Output referred)	OoB_OIM2	-31.3	dBm	f <sub>1</sub> = 824 MHz; f <sub>2</sub> = 2400 MHz, Pin = -30dBm Measure at 1576 MHz
Stability	k	>1		Unconditionally stable from 0 to 10GHz

**Table 4 Electrical Characteristics (at room temperature) at Vcc =2.8V**

Parameter	Symbol	Value			Unit	Comment / Test Condition
DC Voltage	Vcc	2.8			V	V <sub>PON</sub> = V <sub>CC</sub>
DC Current	Icc	2.8			mA	
Navigation System	Sys	Beidou	GPS Galileo	GLONASS		
Frequency Range	Freq	1559 - 1563	1575.42 1559 - 1591	1598-1609	MHz	Beidou: 1561.098 MHz GPS/Galileo: 1575.42 MHz GLONASS: 1602 MHz
Gain	G	19.6	19.6	19.5	dB	
Noise Figure	NF	0.72	0.73	0.74	dB	Loss of input line of 0.07 dB is deembedded
Input Return Loss	RLin	11.1	11.3	11.5	dB	
Output Return Loss	RLout	15.0	18.5	26.9	dB	
Reverse Isolation	IRev	37.0	37.1	37.2	dB	
Input P1dB	IP1dB	-11.9	-12.0	-12.1	dBm	
Output P1dB	OP1dB	6.7	6.6	6.4	dBm	
Input IP3	IIP3	-9.2	-9.1	-8.7	dBm	f <sub>1Beidou</sub> = 1561.098 MHz, f <sub>2 Beidou</sub> = 1562.098 MHz; f <sub>1gps/galileo</sub> = 1575.42 MHz, f <sub>2gps/Galileo</sub> = 1576.42 MHz; f <sub>1GLONASS</sub> = 1602 MHz, f <sub>2GLONASS</sub> = 1603 MHz; Pin = -30 dBm
Out-of-band IP3 (Input referred)	Oob_IIP3	-4.5			dBm	f1 = 1712.7 MHz; f2 = 1850 MHz, Pin = -20dBm
Out-of-band IM3 (Output referred)	Oob_OIM3	-31.5			dBm	Measure at 1575.4 MHz
LTE band-13 2 <sup>nd</sup> Harmonic (Input referred)	B13 H2in	-43.0			dBm	
LTE band-13 2 <sup>nd</sup> Harmonic (Output referred)	B13 H2out	-23.4			dBm	f <sub>IN</sub> = 787.7 MHz, P <sub>IN</sub> = -25 dBm; f <sub>H2</sub> = 1575.4 MHz
Out-of-band IM2 (Input referred)	Oob_IIM2	-50.9			dBm	
Out-of-band IM2 (Output referred)	Oob_OIM2	-31.3			dBm	f1 = 824 MHz; f2 = 2400 MHz, Pin = -30dBm, measure at 1576 MHz
Stability	k	>1			--	Unconditionally stable from 0 to 10GHz



### 3.2 BGA524N6 as Low Noise Amplifier for GNSS Applications Using a High Q Inductor for Matching

This application note presents the BGA524N6 performance on a FR4 board at 1550 MHz – 1615 MHz. Results under 1.8 V and 2.8 V supply voltages are presented. The LNA BGA524N6 features a current consumption of less than 3 mA at both supply conditions.

At 1.8V, 1575.42MHz, the BGA524N6 LNA obtains gain of 19.5 dB and noise figure of 0.74 dB excluding SMA and line losses. The input return loss and output return loss are above 10 dB. It offers an input 1 dB compression point of – 15.6 dBm. Using two tones of -30 dBm spacing 1 MHz, the input Third-order intercept point is -9.6 dBm. The input out-of-band Third-order intercept point is –5.9 dBm using two tones of -20 dBm per tone at 1712.7 MHz and 1850 MHz. The LTE band 13 second harmonic is -41.8dBm (input referred) at 1575.4 MHz using one tone of - 25 dBm per tone at 787.7 MHz.

At 2.8V, 1575.42MHz, the BGA524N6 LNA obtains gain of 19.6 dB and a noise figure of 0.73 dB excluding SMA and line losses. The input return loss and output return loss are above 10 dB. It offers an input 1 dB compression point of – 12.0 dBm. Using two tones of -30 dBm spacing 1 MHz, the input Third-order intercept point is -9.1 dBm. The input out-of-band Third-order intercept point is –4.4 dBm using two tones of -20 dBm per tone at 1712.7 MHz and 1850 MHz. The LTE band 13 second harmonic is -43.0 dBm (input referred) at 1575.4 MHz using one tone of - 25 dBm per tone at 787.7 MHz.

The circuit is unconditionally stable up to 10 GHz.

Note: for more information regarding to out-of-band IP3 and LTE band 13 second harmonic, please refer to the Application Guide ‘Mobile Communication’.

### 3.3 Schematics and Bill-of-Materials

The schematic of BGA524N6 for GNSS applications is presented in **Figure 4** and its bill-of-materials is shown in **Table 5**.

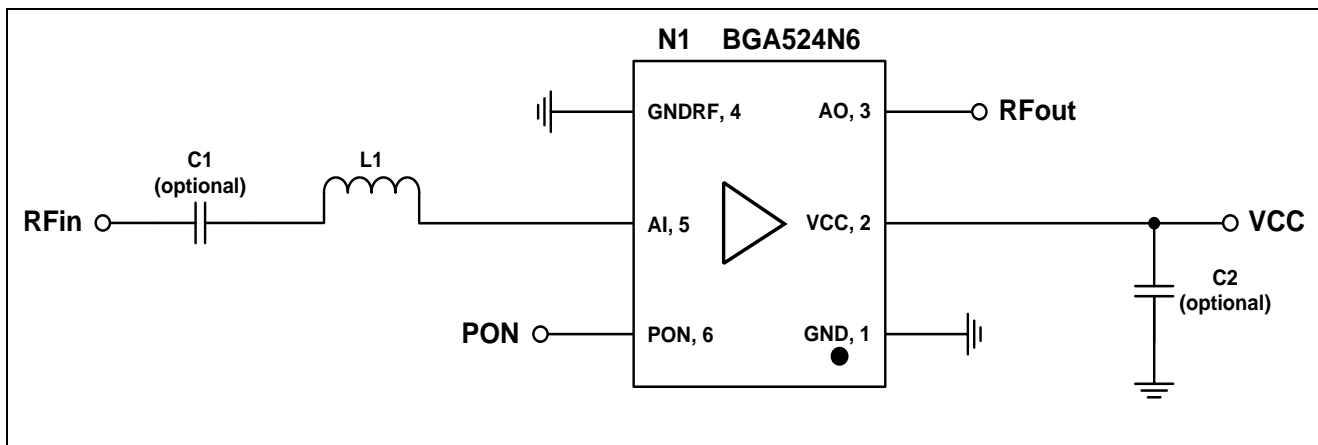

**Figure 4 Schematics of the BGA524N6 Application Circuit**

**Table 5 Bill-of-Materials**

Symbol	Value	Unit	Size	Manufacturer	Comment
C1 (optional)	$\geq 1$	nF	0402	Various	DC block
C2 (optional)	$> 10$	nF	0402	Various	RF bypass
L1	8.2	nH	0402	Murata LQW15 series	Input matching
N1	BGA524N6		TSNP-6-2	Infineon	SiGe LNA

*Note: DC block function is NOT integrated at input of BGA524N6. The DC block capacitor C1 is not necessary if the DC block function on the RF input line can be ensured by the previous stage.*

*Note: The RF bypass capacitor C2 at the DC power supply pin filters out the power supply noise and stabilize the DC supply. The RF bypass capacitor C2 is not necessary if a clean and stable DC supply can be ensured.*

## 4 Measurement Graphs

The performance of the application circuit is presented with the following graphs.

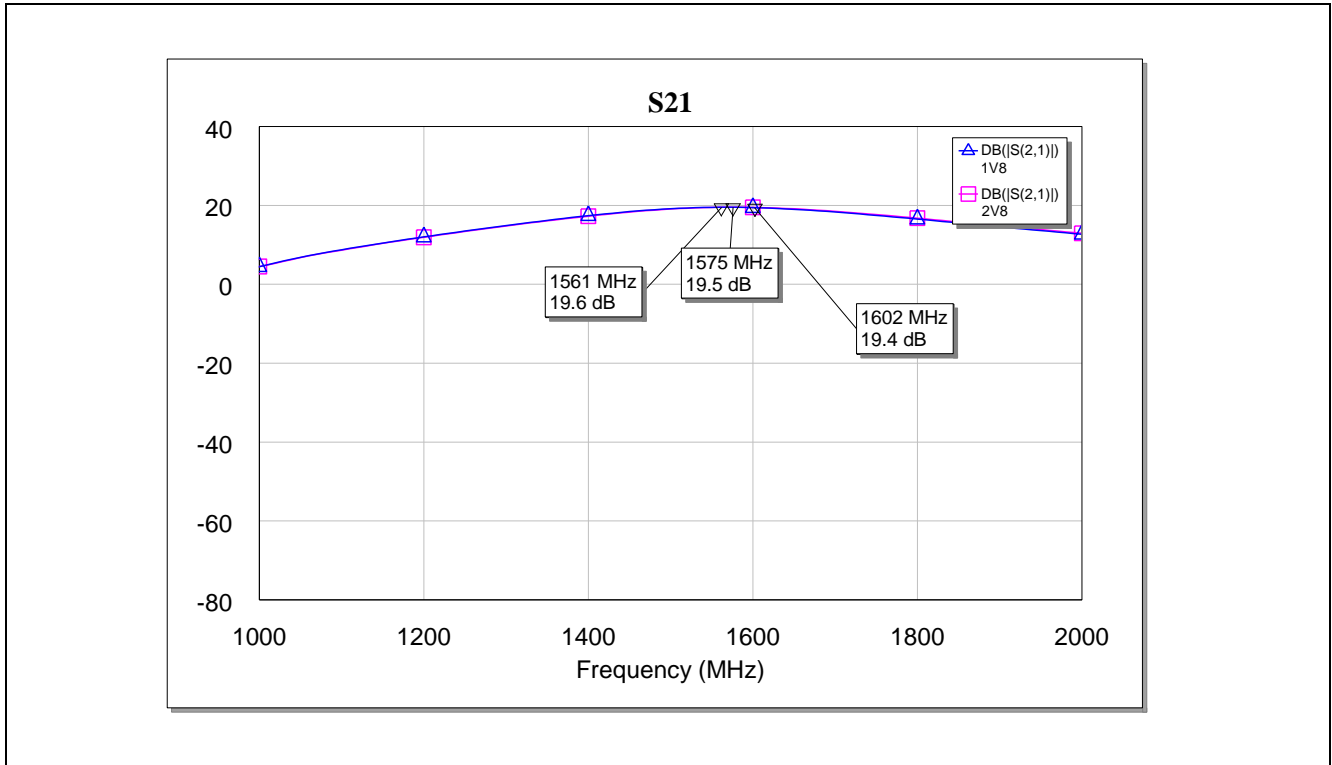

Figure 5 Narrowband Gain of the BGA524N6 as LNA for GNSS applications

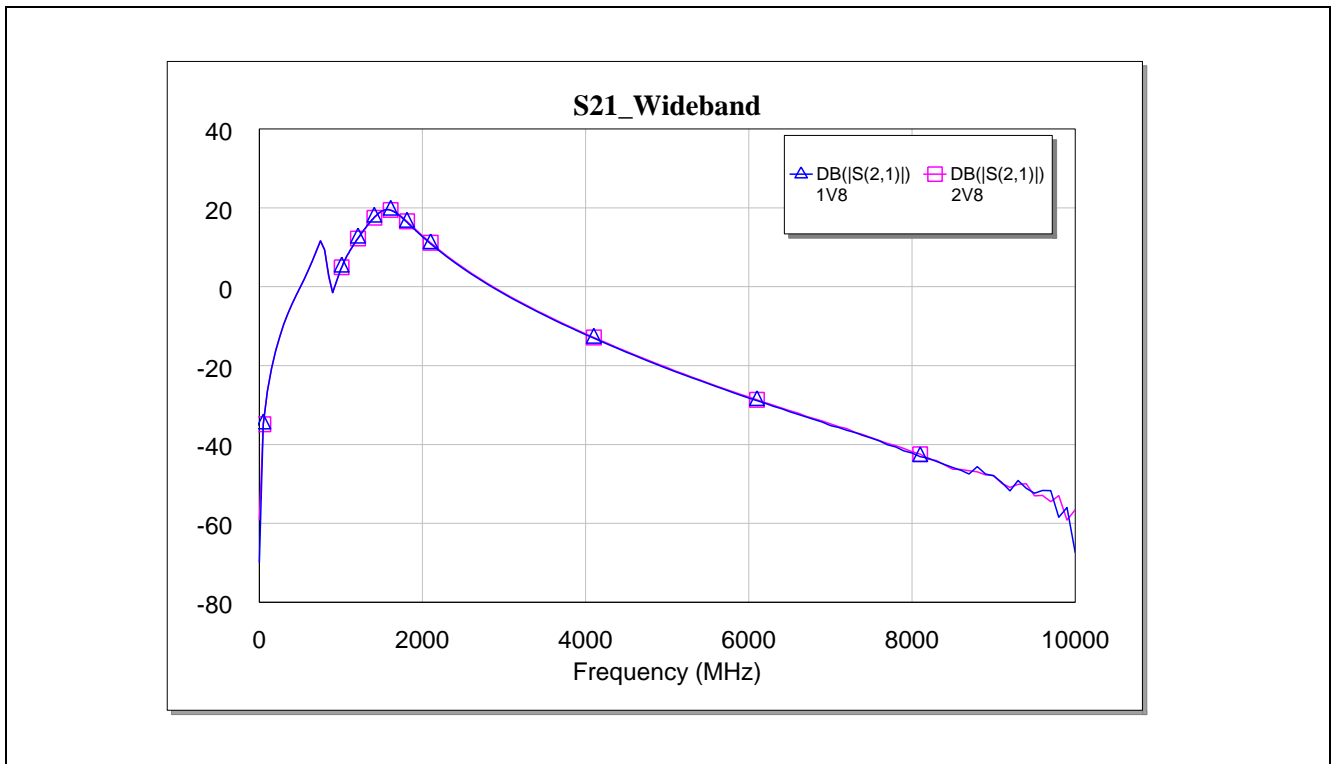

Figure 6 Wideband Gain of BGA524N6 as LNA for GNSS applications

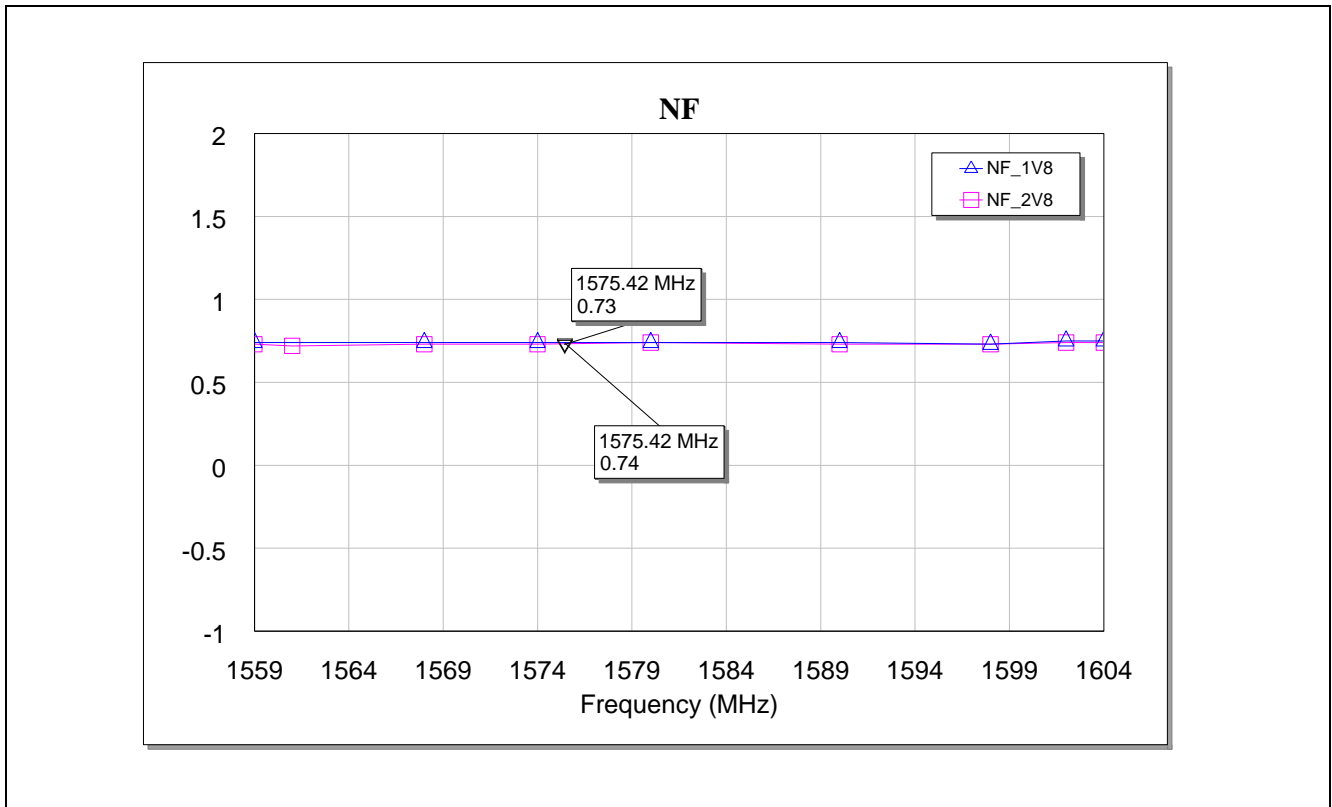

Figure 7 Noise Figure of BGA524N6 as LNA for GNSS applications

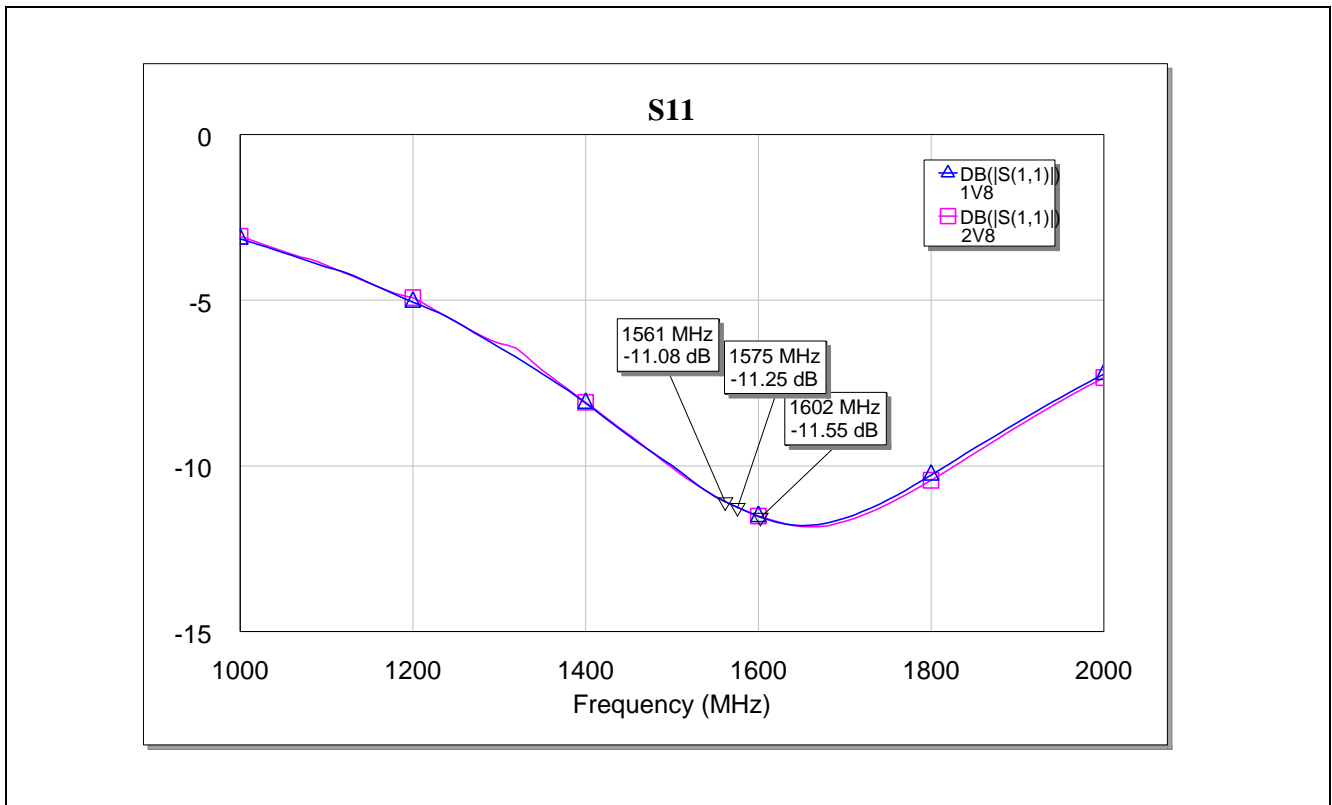

Figure 8 Input matching of BGA524N6 as LNA for GNSS applications

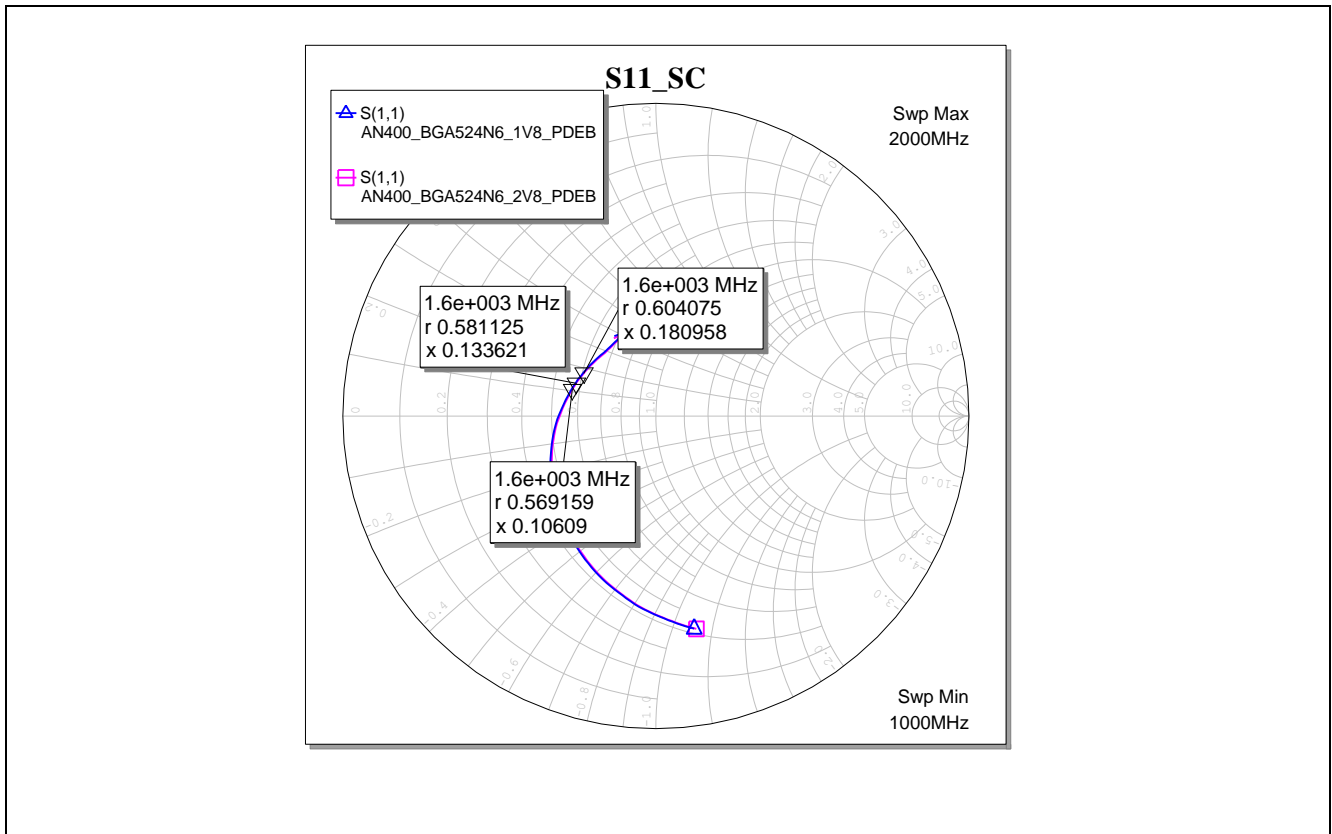

Figure 9 Input matching (Smith chart) of BGA524N6 as LNA for GNSS applications

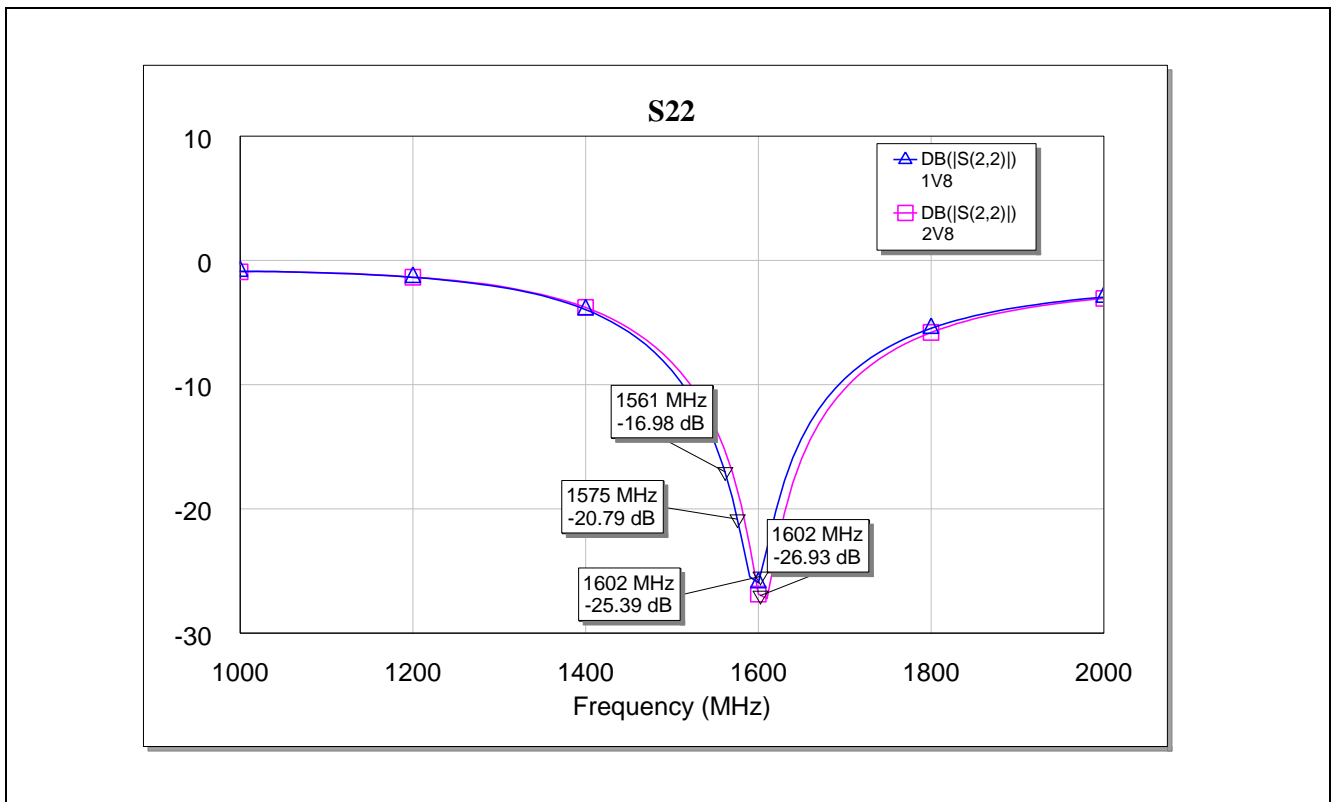

Figure 10 Output matching of the BGA524N6 as LNA for GNSS applications



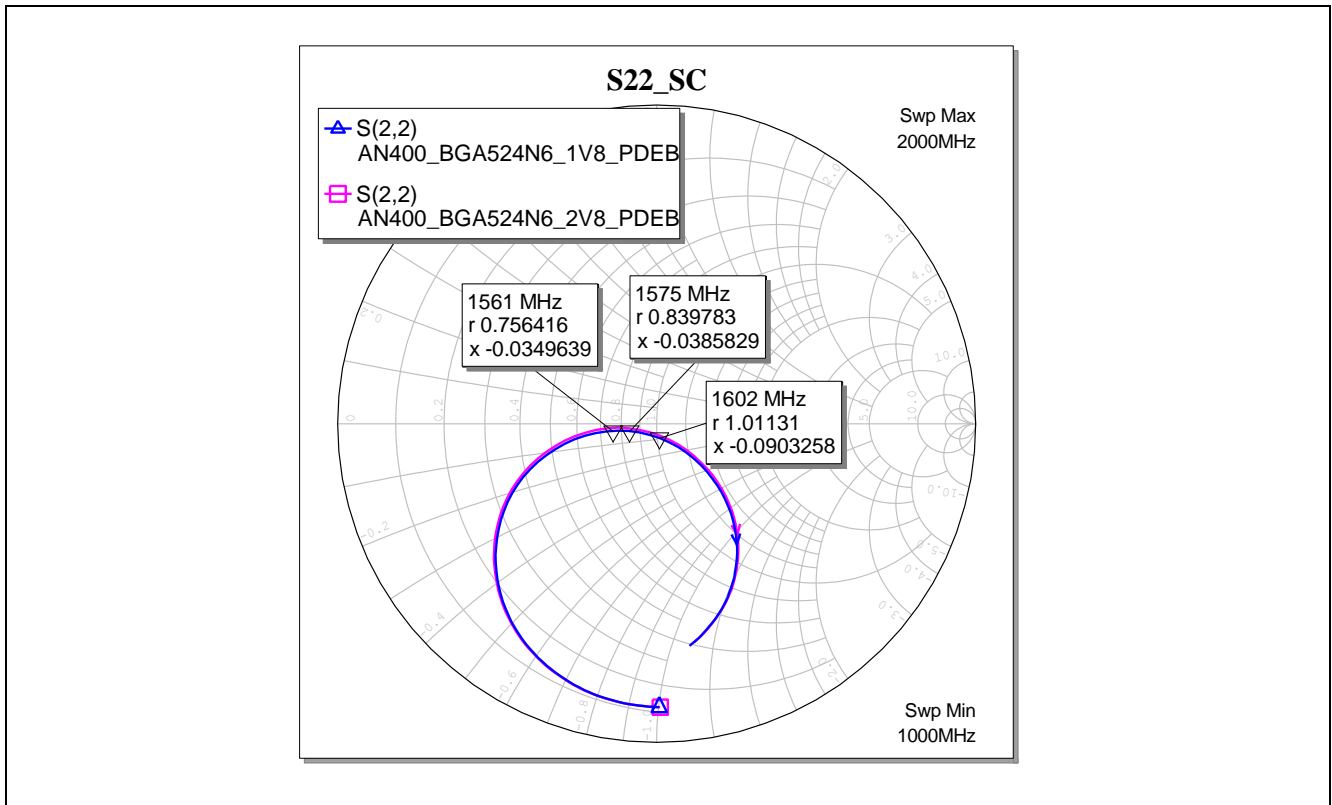

Figure 11 Output matching (Smith chart) of BGA524N6 as LNA for GNSS applications

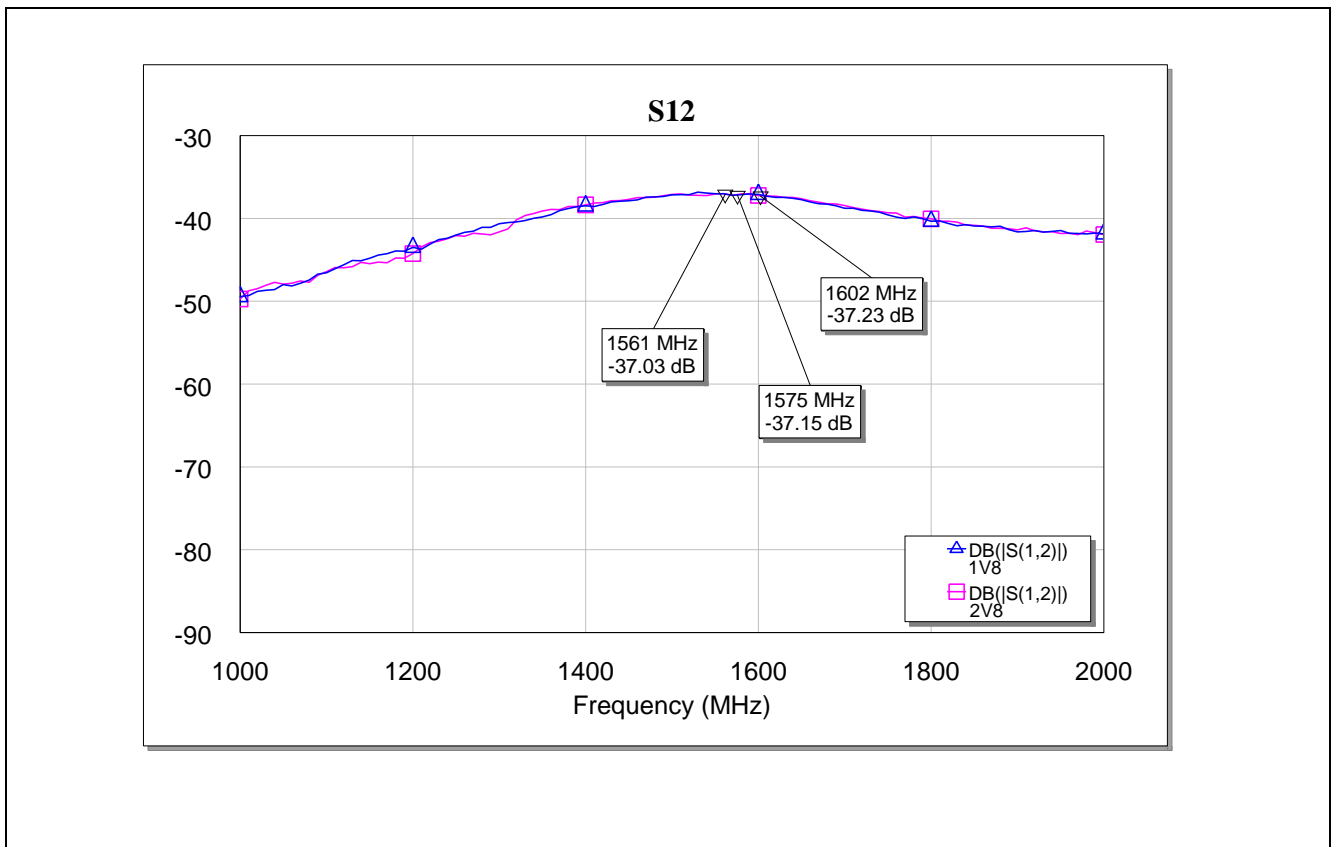

Figure 12 Isolation of BGA524N6 as LNA for GNSS applications

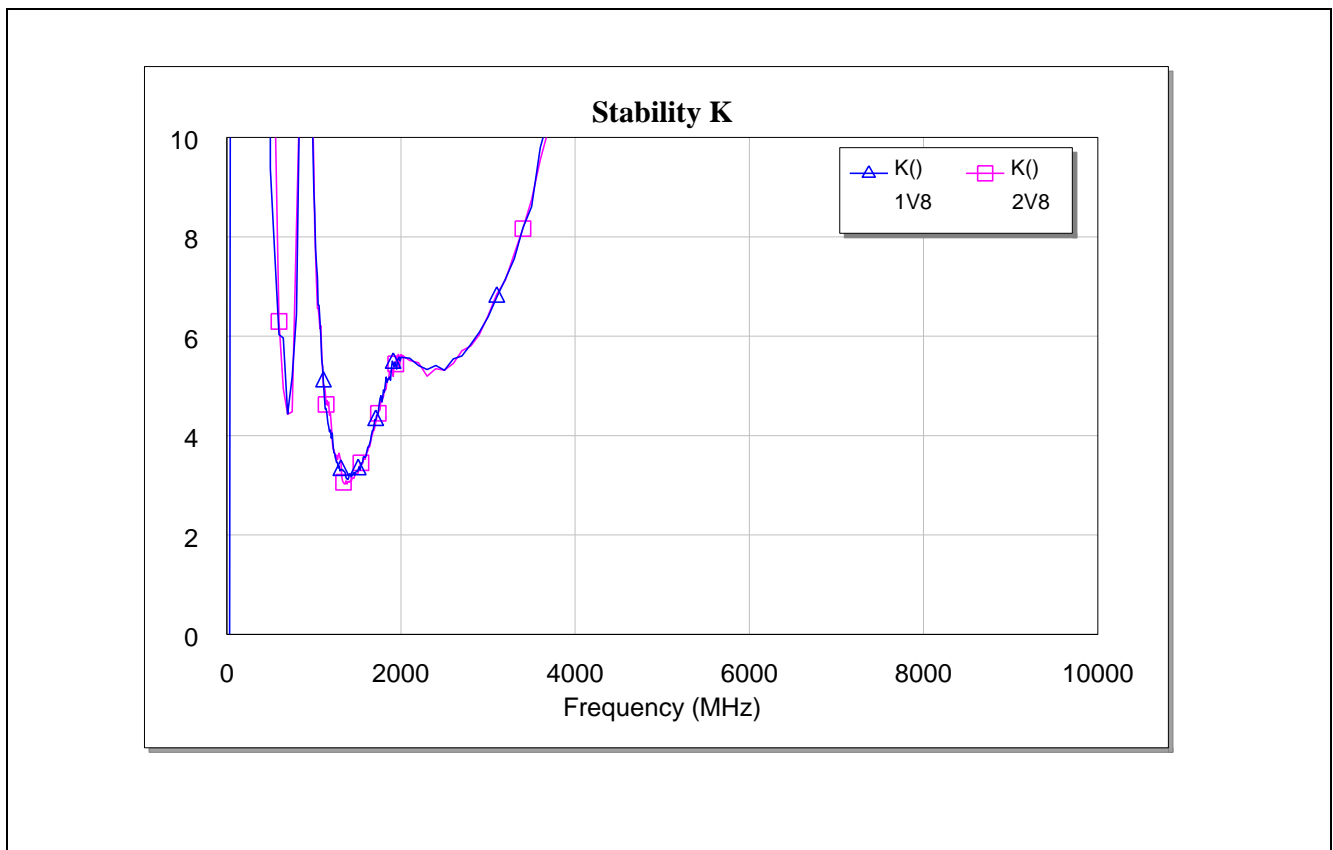

Figure 13 Stability factor k of BGA524N6 as LNA for GNSS applications

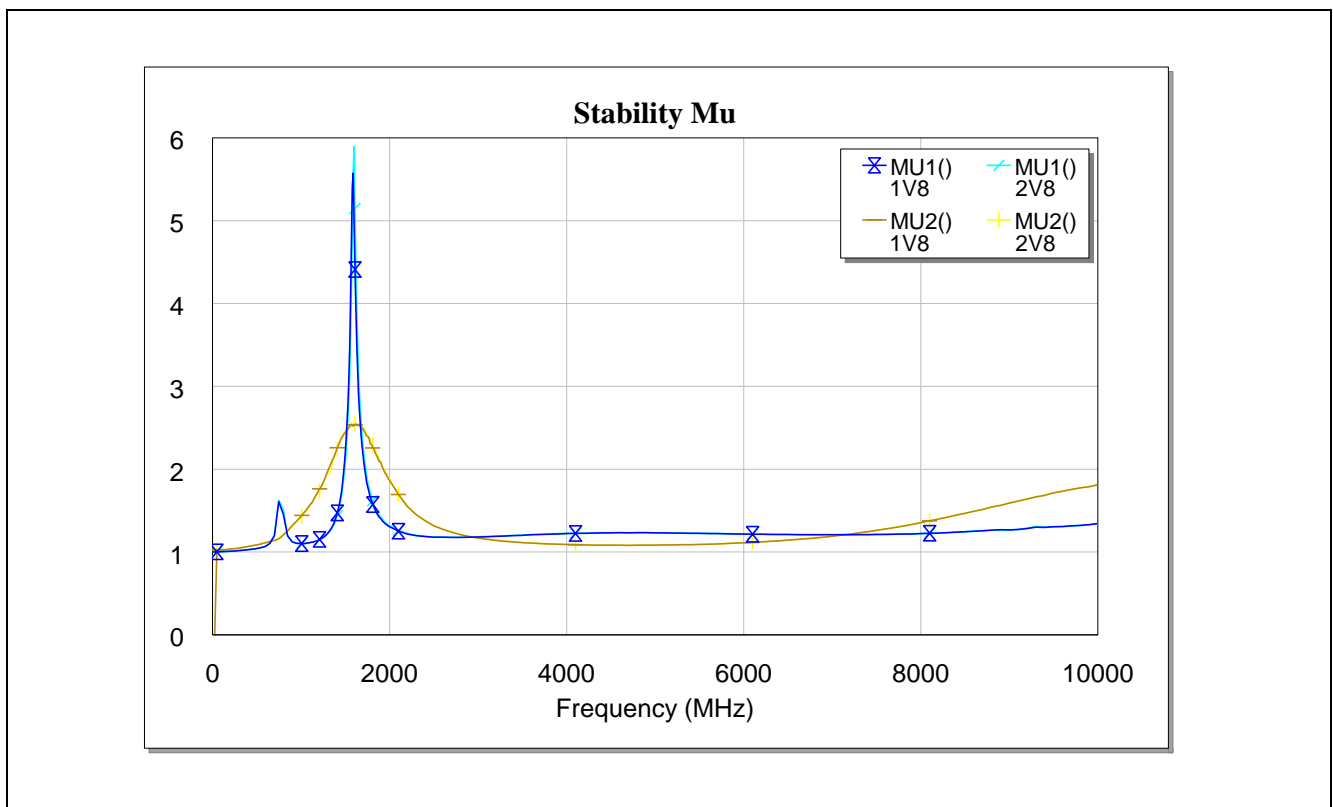

Figure 14 Stability factors  $\mu_1$ ,  $\mu_2$  of the BGA524N6 as LNA for GNSS applications

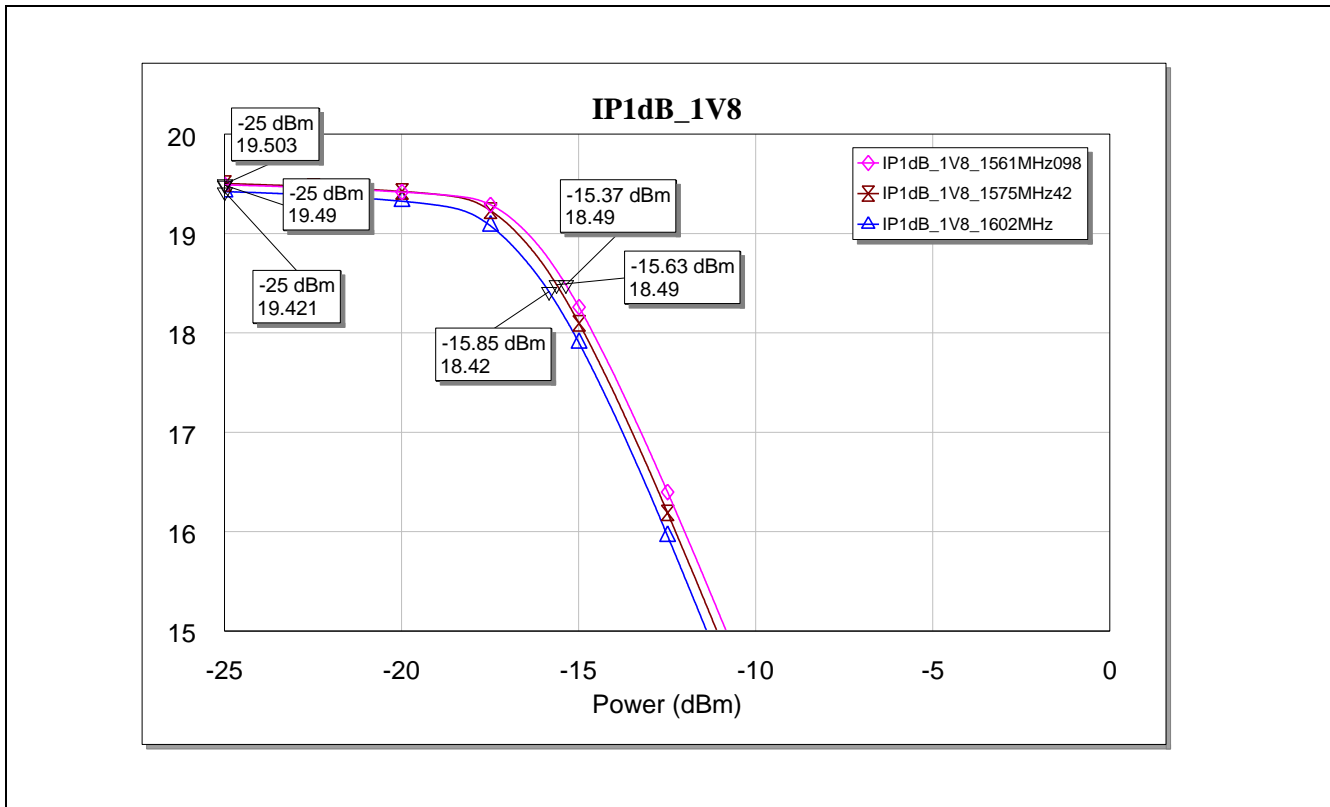

Figure 15 IP1dB of the BGA524N6 as LNA for GNSS applications (1.8V)

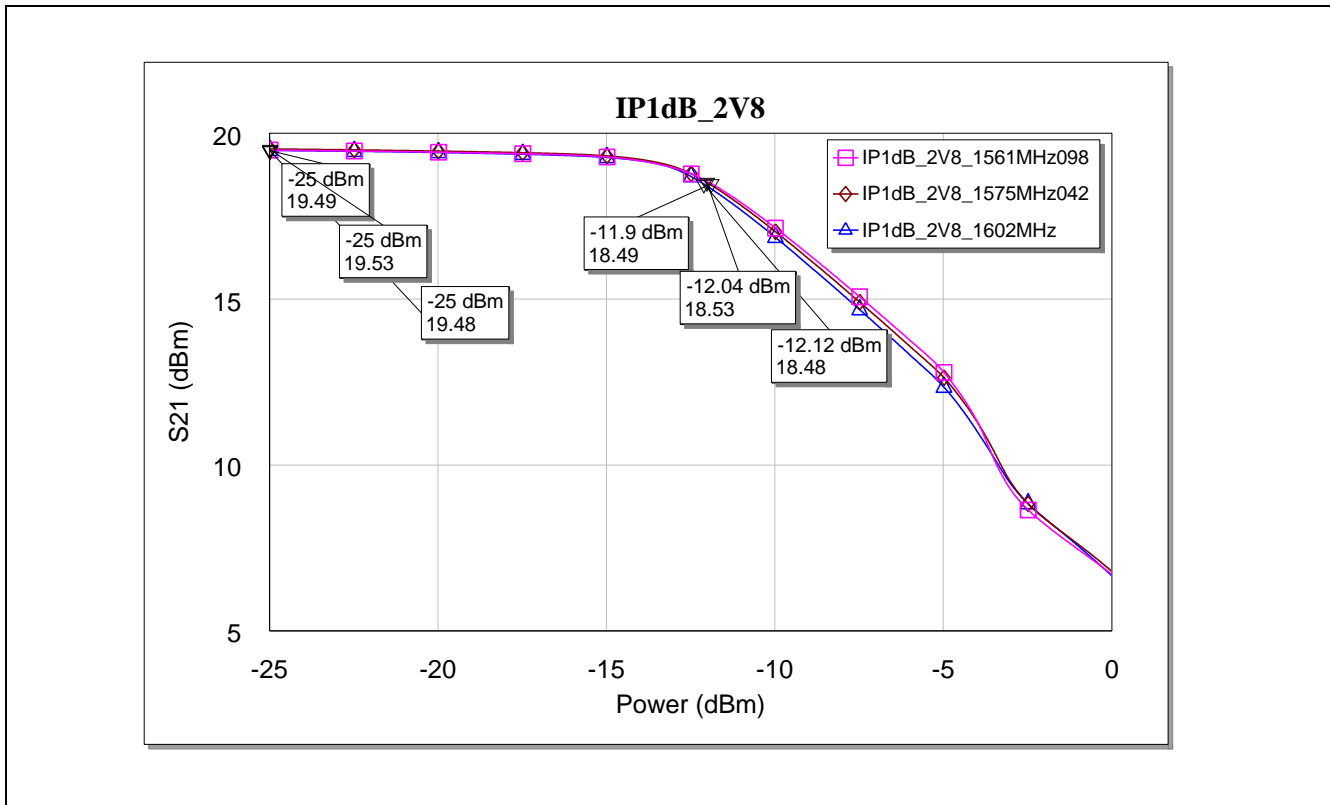

Figure 16 IP1dB of the BGA524N6 as LNA for GNSS applications (2.8V)

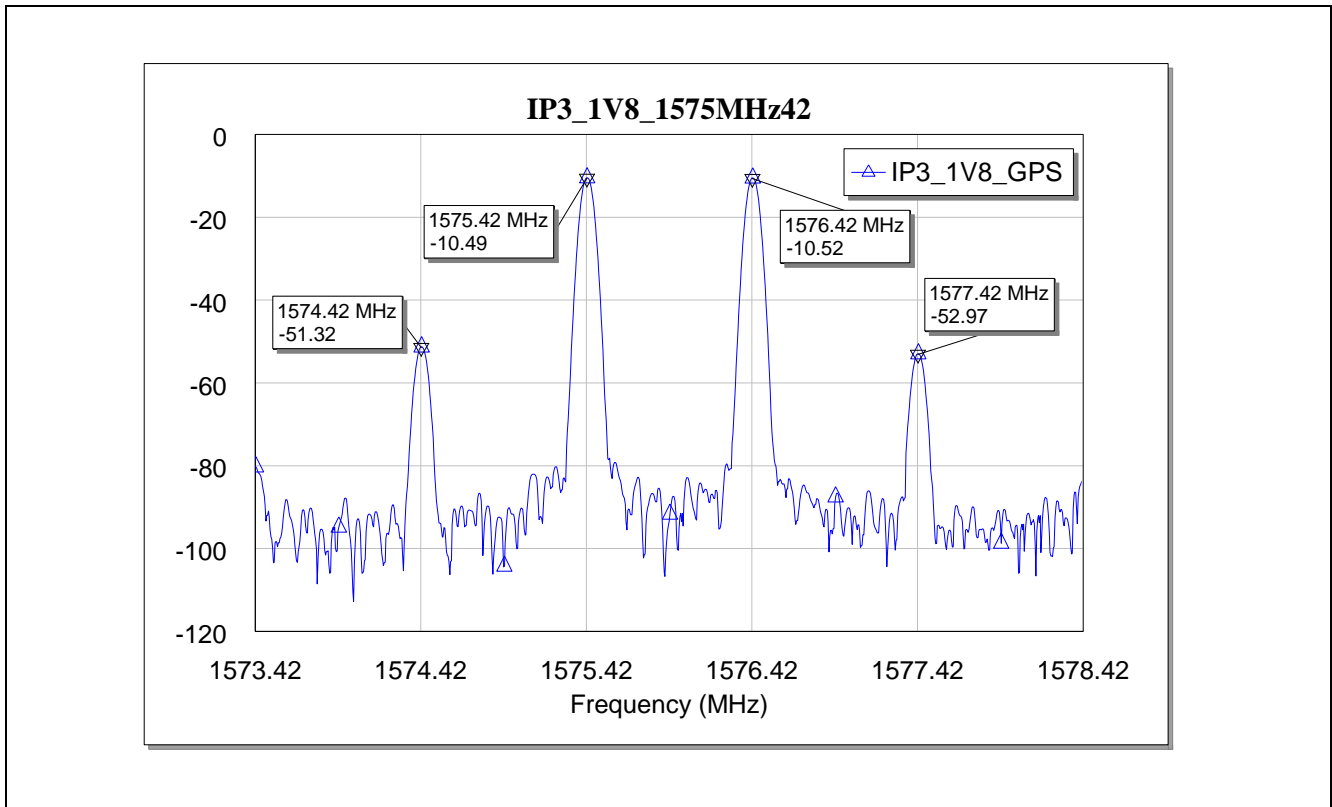

Figure 17 Output IP3 of the BGA524N6 as LNA for GNSS applications (1.8V)

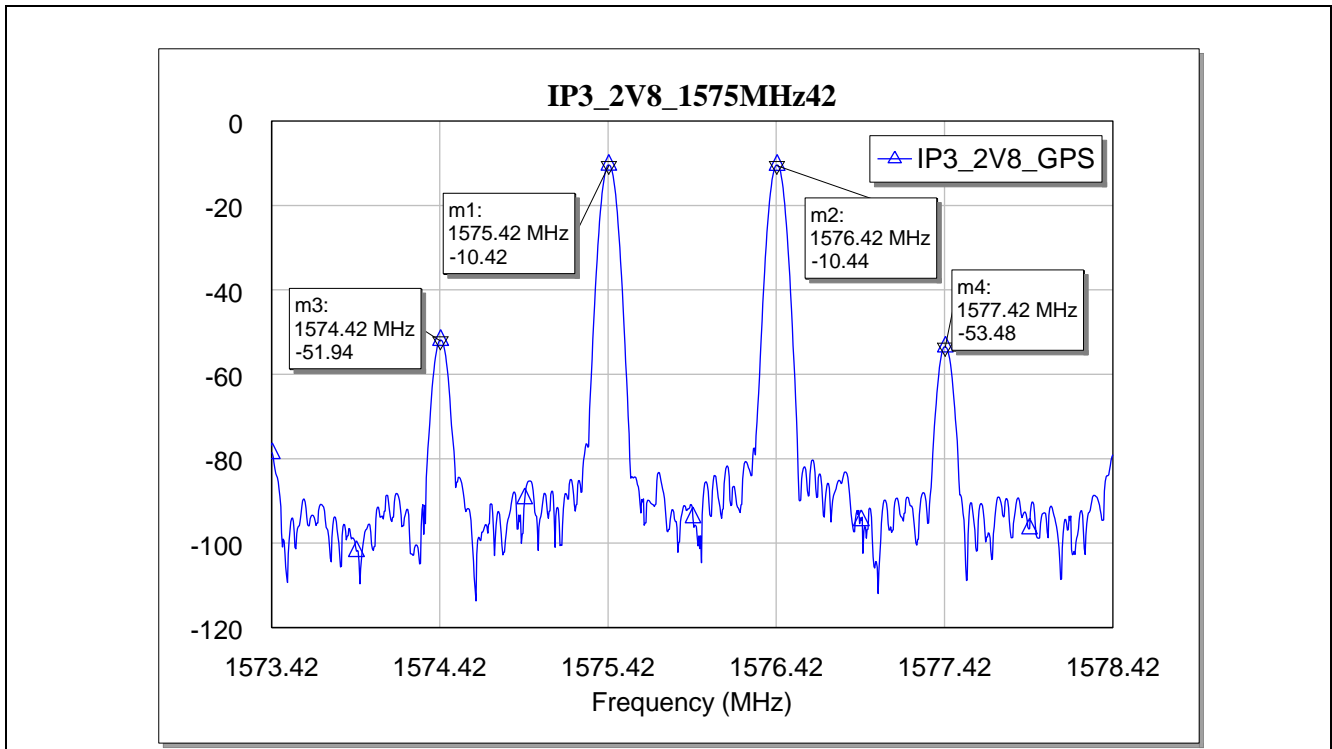

Figure 18 Output IP3 of the BGA524N6 as LNA for GNSS applications (2.8V)

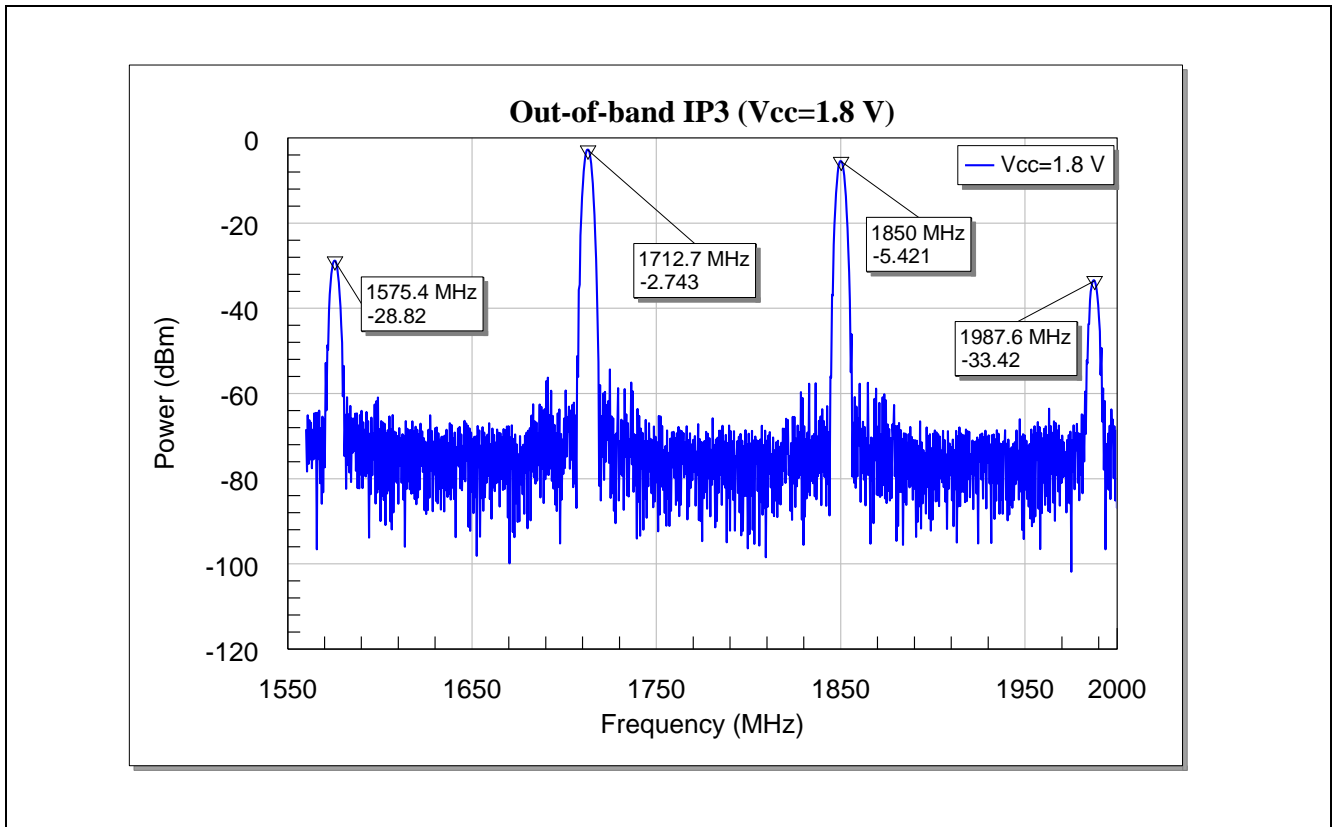

Figure 19 Out-of-band IP3 of the BGA524N6 as LNA for GNSS applications (1.8V)

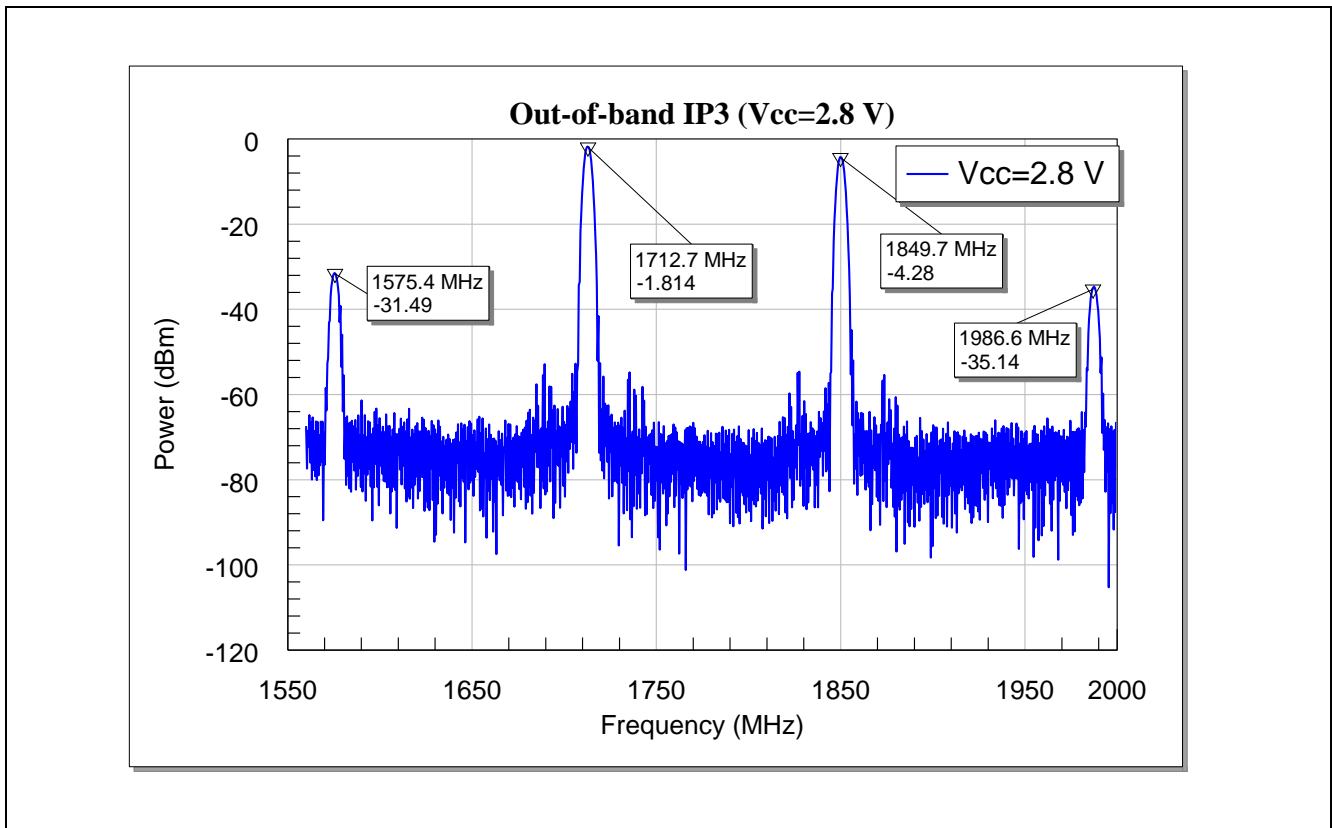

Figure 20 Out-of-band IP3 of the BGA524N6 as LNA for GNSS applications (2.8V)

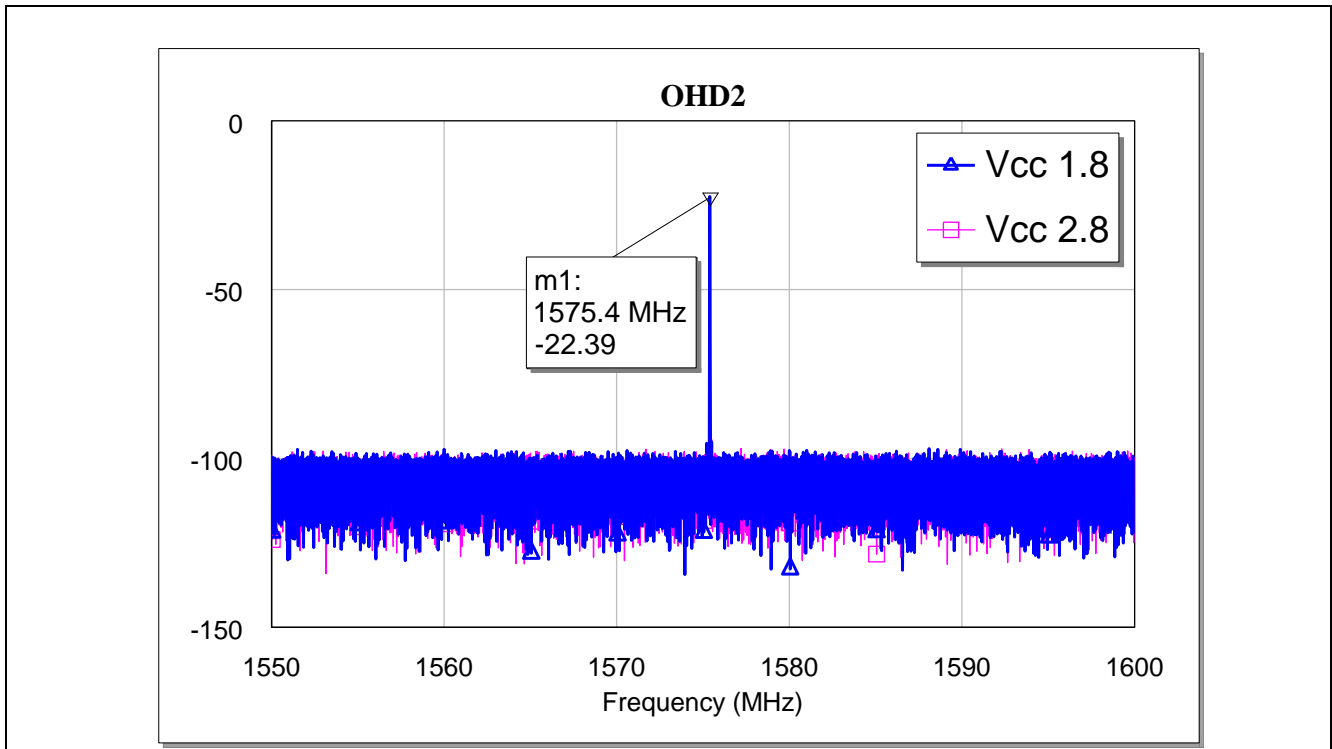

Figure 21 LTE Band 13 Second Harmonic Interference of the BGA524N6 as LNA for GNSS applications (LNA output referred)

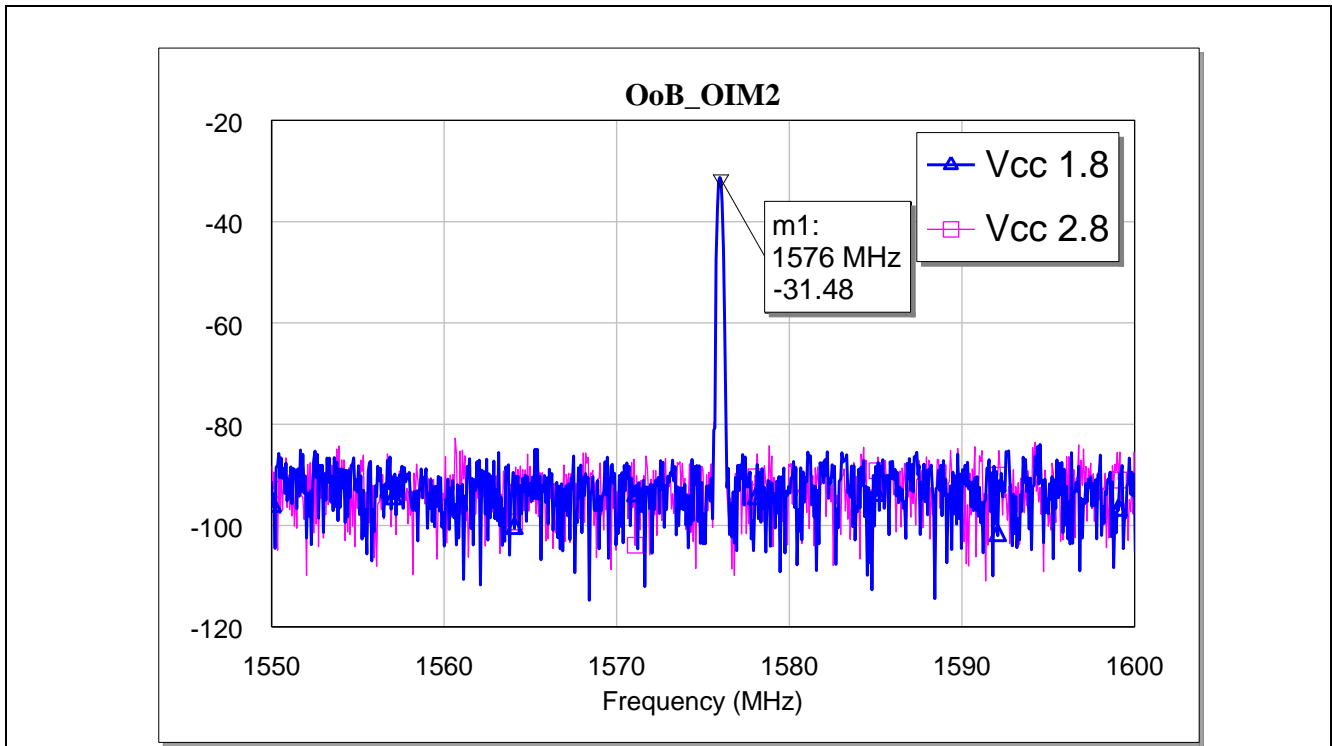

Figure 22 Out-of-band Second Harmonic of the BGA524N6 as LNA for GNSS applications (LNA output referred),  $f_{in} = 824\text{MHz} -30\text{dBm}$ ,  $f_{2in} = 2400\text{MHz} -30\text{ dBm}$

## 5 Evaluation Board and Layout Information

In this application note, the following PCB is used:

PCB Marking: BGAX24N6 V3.1

PCB material: **FR4**

$\epsilon_r$  of PCB material: 4.3

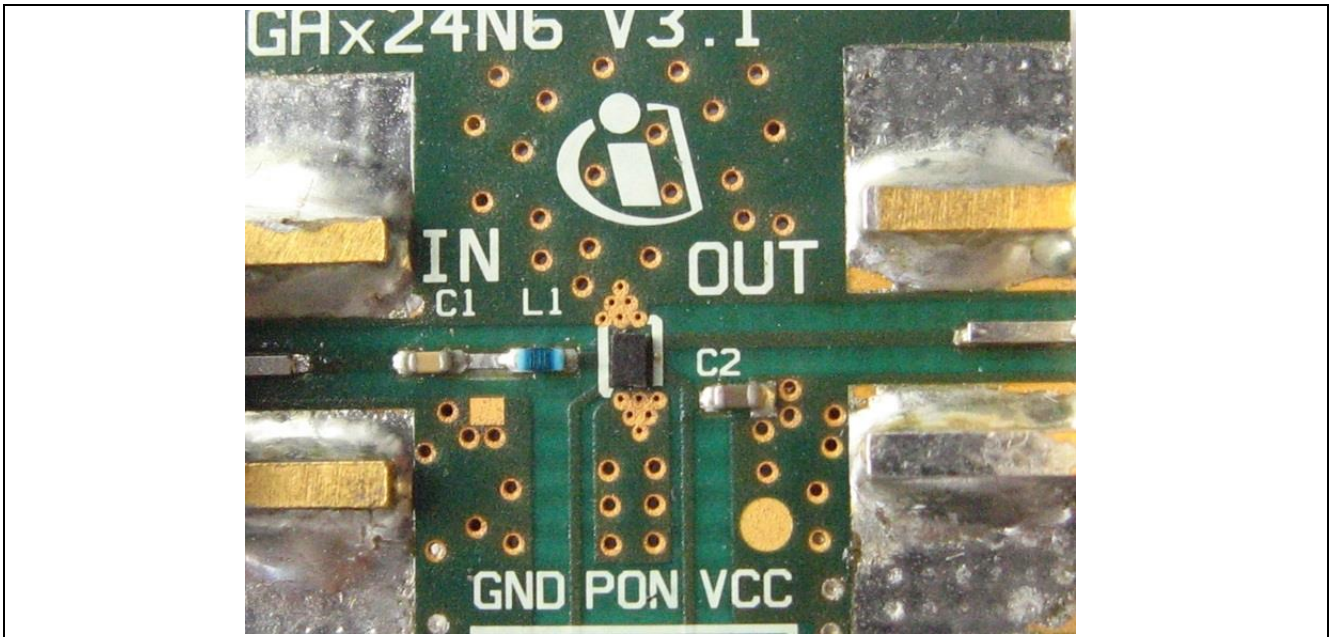

Figure 23 Photo Picture of Evaluation Board (overview)

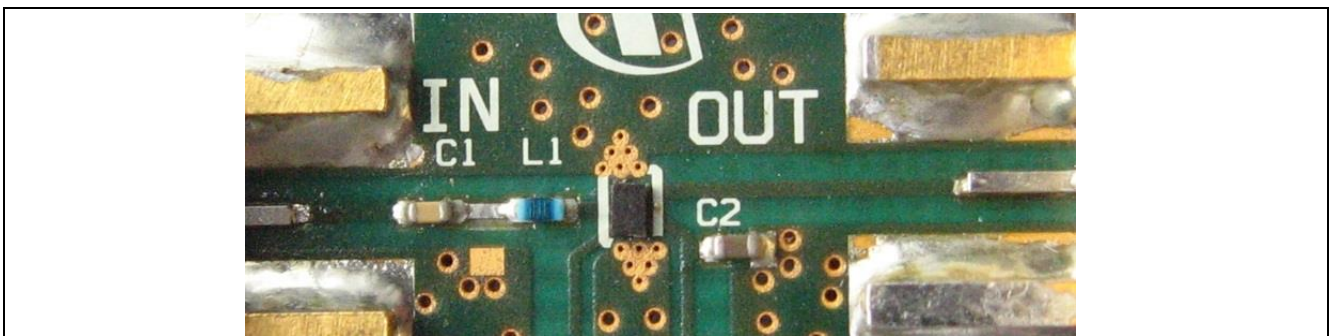

Figure 24 Photo Picture of Evaluation Board (detailed view)

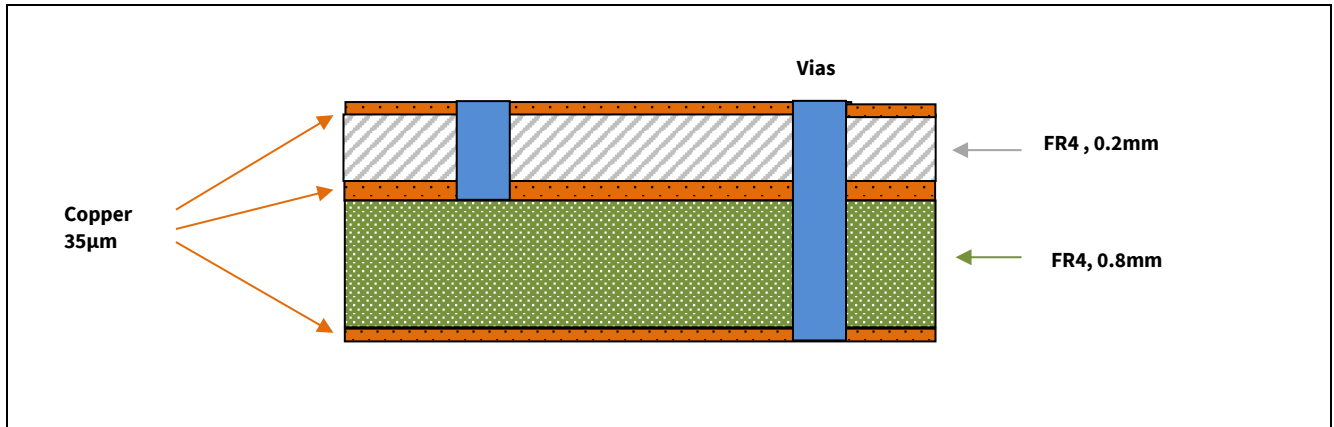

Figure 25 PCB Layer Information





## 6 Authors

Xiang Li, Senior Application Engineer of Business Unit “Radio Frequency and Sensors”

Islam Moakhhkhrul, Application Engineer of Business Unit “Radio Frequency and Sensors”

## 7 Reference

- [1] Application Guide ‘Mobile Communication, Edition 2014’, Business Unit “Radio Frequency and Sensors”, Infineon Technologies [www.infineon.com](http://www.infineon.com)
- [2] Application Note AN346: ‘Low Noise Amplifier for Global Navigation Satellite Systems GPS/GLONASS/Galileo/COMPASS from 1550 MHz to 1615 MHz Applications, Low Q inductor’. Revision 1.1, Infineon Technologies

## Revision History

### Major changes since the last revision 1.0

Page or Reference	Description of change
22	Added Oob IM2 LTE B5 + Wifi 2.4GHz

#### Trademarks of Infineon Technologies AG

AURIX™, C166™, CanPAK™, CIPOS™, CIPURSE™, CoolGaN™, CoolMOS™, CoolSET™, CoolSiC™, CORECONTROL™, CROSSAVE™, DAVE™, DI-POL™, DrBLADE™, EasyPIM™, EconoBRIDGE™, EconoDUAL™, EconoPACK™, EconoPIM™, EiceDRIVER™, eupec™, FCOST™, HITFET™, HybridPACK™, ISOFACE™, IsoPACK™, i-Wafer™, MIPAQ™, ModSTACK™, my-d™, NovalithIC™, OmniTune™, OPTIGA™, OptiMOS™, ORIGA™, POWERCODE™, PRIMARION™, PrimePACK™, PrimeSTACK™, PROFET™, PRO-SiL™, RASIC™, REAL3™, ReverSave™, SatRIC™, SIEGET™, SIPMOS™, SmartLEWIS™, SOLID FLASH™, SPOC™, TEMPFET™, thinQ!™, TRENCHSTOP™, TriCore™.

#### Other Trademarks

Advance Design System™ (ADS) of Agilent Technologies, AMBA™, ARM™, MULTI-ICE™, KEIL™, PRIMECELL™, REALVIEW™, THUMB™, μVision™ of ARM Limited, UK. ANSI™ of American National Standards Institute. AUTOSAR™ of AUTOSAR development partnership. Bluetooth™ of Bluetooth SIG Inc. CAT-ig™ of DECT Forum. COLOSSUS™, FirstGPS™ of Trimble Navigation Ltd. EMV™ of EMVCo, LLC (Visa Holdings Inc.). EPCOS™ of Epcos AG. FLEXGO™ of Microsoft Corporation. HYPERTERMINAL™ of Hilgraeve Incorporated. MCS™ of Intel Corp. IEC™ of Commission Electrotechnique Internationale. IrDA™ of Infrared Data Association Corporation. ISO™ of INTERNATIONAL ORGANIZATION FOR STANDARDIZATION. MATLAB™ of MathWorks, Inc. MAXIM™ of Maxim Integrated Products, Inc. MICROTEC™, NUCLEUS™ of Mentor Graphics Corporation. MIPI™ of MIPI Alliance, Inc. MIPS™ of MIPS Technologies, Inc., USA. muRata™ of MURATA MANUFACTURING CO., MICROWAVE OFFICE™ (MWO) of Applied Wave Research Inc., OmniVision™ of OmniVision Technologies, Inc. Openwave™ of Openwave Systems Inc. RED HAT™ of Red Hat, Inc. RFMD™ of RF Micro Devices, Inc. SIRIUS™ of Sirius Satellite Radio Inc. SOLARIS™ of Sun Microsystems, Inc. SPANSION™ of Spansion LLC Ltd. Symbian™ of Symbian Software Limited. TAIYO YUDEN™ of Taiyo Yuden Co. TEAKLITE™ of CEVA, Inc. TEKTRONIX™ of Tektronix Inc. TOKO™ of TOKO KABUSHIKI KAISHA TA. UNIX™ of X/Open Company Limited. VERILOG™, PALLADIUM™ of Cadence Design Systems, Inc. VLYNQ™ of Texas Instruments Incorporated. VXWORKS™, WIND RIVER™ of WIND RIVER SYSTEMS, INC. ZETEX™ of Diodes Zetex Limited.

Last Trademarks Update 2014-07-17

[www.infineon.com](http://www.infineon.com)

**Edition 2018-02-09**

**Published by**

**Infineon Technologies AG**

**81726 Munich, Germany**

**© 2024 Infineon Technologies AG.**

**All Rights Reserved.**

**Do you have a question about any aspect of this document?**

**Email: [erratum@infineon.com](mailto:erratum@infineon.com)**

**Document reference**

**AN\_201410\_PL32\_010**

#### Legal Disclaimer

THE INFORMATION GIVEN IN THIS APPLICATION NOTE (INCLUDING BUT NOT LIMITED TO CONTENTS OF REFERENCED WEBSITES) IS GIVEN AS A HINT FOR THE IMPLEMENTATION OF THE INFINEON TECHNOLOGIES COMPONENT ONLY AND SHALL NOT BE REGARDED AS ANY DESCRIPTION OR WARRANTY OF A CERTAIN FUNCTIONALITY, CONDITION OR QUALITY OF THE INFINEON TECHNOLOGIES COMPONENT. THE RECIPIENT OF THIS APPLICATION NOTE MUST VERIFY ANY FUNCTION DESCRIBED HEREIN IN THE REAL APPLICATION. INFINEON TECHNOLOGIES HEREBY DISCLAIMS ANY AND ALL WARRANTIES AND LIABILITIES OF ANY KIND (INCLUDING WITHOUT LIMITATION WARRANTIES OF NON-INFRINGEMENT OF INTELLECTUAL PROPERTY RIGHTS OF ANY THIRD PARTY) WITH RESPECT TO ANY AND ALL INFORMATION GIVEN IN THIS APPLICATION NOTE.

#### Information

For further information on technology, delivery terms and conditions and prices, please contact the nearest Infineon Technologies Office ([www.infineon.com](http://www.infineon.com)).

#### Warnings

Due to technical requirements, components may contain dangerous substances. For information on the types in question, please contact the nearest Infineon Technologies Office. Infineon Technologies components may be used in life-support devices or systems only with the express written approval of Infineon Technologies, if a failure of such components can reasonably be expected to cause the failure of that life-support device or system or to affect the safety or effectiveness of that device or system. Life support devices or systems are intended to be implanted in the human body or to support and/or maintain and sustain and/or protect human life. If they fail, it is reasonable to assume that the health of the user or other persons may be endangered.