

## Power Management - Battery Charger with Cell-Balancing and Fuel Gauge Function Support

**Author: Oleksandr Karpin**

**Associated Project: Yes**

**Associated Part Family: CY8C27x43, CY8C29x66**

**Software Version: PSoC® Designer™ 5.1**

**Associated Application Notes: [AN2180](#), [AN2314](#)**

AN2344 integrates cell-balancing and fuel gauge methods into a multi-cell battery charger. The application is designed for battery packs with two, three, or four Li-Ion or Li-Pol cells in a series. It includes dedicated PC-based software for real-time viewing and analysis of the charge, cell-balance and fuel gauge processes. The application can be used as a complete battery pack management system for notebooks, medical and industrial equipment, and other, similar applications.

### Contents

Introduction .....	1
Regulator Topologies .....	3
Buck Converter.....	3
Buck-Boost Converter .....	4
SEPIC.....	4
Device Schematic.....	5
Multi-Cell Battery Charger Firmware .....	9
Conclusion .....	9
Appendix A: Charge, Discharge, Cell-Balance and Fuel Gauge Profile Examples.....	10
Worldwide Sales and Design Support.....	14

### Introduction

This Application Note combines the cell-balancing method, “Cell Balancing in a Multi-Cell Li-Ion/Li-Pol Battery Charger,” and the fuel gauge method, “Li-Ion/Li-Polymer Battery Charger with Fuel Gauge Function” with a multi-cell battery charger into a complete battery pack management system. This battery pack management system provides:

- Correct charging of two, three, or four Li-Ion or Li-Pol cells in a series with one or more cells in parallel.
- Protection from overcharge, deep discharge, and short circuit conditions.
- Temperature detection that shuts off the charging or discharging processes when battery temperature is outside the allowed temperature range.
- Cell balancing in the battery pack.
- Calculation of fuel gauge parameters including absolute capacity, state of charge, and run and charge time remaining.

This Application Note also includes dedicated PC-based software developed to allow real-time viewing and analysis of the charge, cell-balance, and fuel gauge

Figure 1 shows the battery pack management system schematic.

Figure 1. Battery Pack Management Schematic

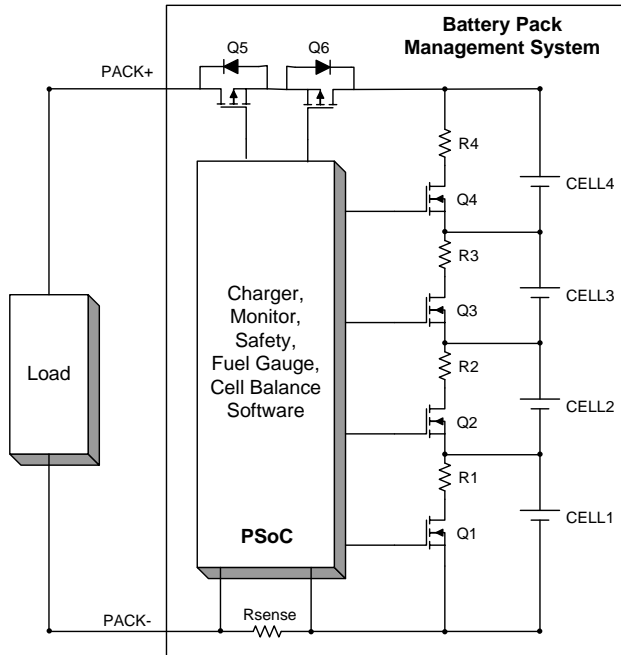

The battery back management system provides correct battery pack charge and discharge processes. The only external connections required are the external power supply connections to PACK+ and PACK-.

A safety circuit, internal to the PSoC® device, controls the back-to-back MOSFET switches, Q5 and Q6. These switches are opened to protect the pack against fault conditions such as overcharge, deep discharge, and over-current. The resistor, Rsense, is a current-sense resistor that is in the battery pack current path. The fuel gauge accumulates the measured current to determine the available capacity of the battery pack. The cell-balancing circuit is represented by R1 and Q1) to R4 and Q4. These transistors and resistors dissipate energy and control the amount of balancing current to provide cell balancing in the battery pack.

The unique architecture of the PSoC device provides an integrated hardware solution for a multi-cell battery charger with minimal external components at a very affordable price.

It also provides flexible microcontroller-based cell-balancing and fuel gauge algorithms. You can upgrade algorithms with the latest charge, cell-balance, or fuel gauge technologies with a firmware change.

This system uses its own COM-based protocol for communication between the battery pack management system and the host device. You can implement the SMBus protocol in the PSoC firmware, if desired.

The characteristics and software capabilities of the multi-cell Li-Ion and Li-Pol battery charger with cell-balance and fuel gauge functions are listed in Table 1.

Table 1. Specifications for Multi-Cell Li-Ion and Li-Pol Battery Charger

Item	Specification
<b>Battery Charger</b>	
Power Supply Voltage	6..25 V
Power Consumption	30 mA
<ul style="list-style-type: none"> <li>Active Mode</li> <li>Sleep Mode<sup>1</sup></li> </ul>	8 mA
Battery Temp. Measurement Range (Software Configurable)	-20..60 °C
Battery Current Measurement Error (Not Calibrated)	5%
Battery Voltage Measurement Error (After Calibration)	0.5%
Temperature Measurement Absolute Error	1 °C
User Interface	2 Buttons and 2 State LEDs
PC Communication Interface	RS232
PC Communication Speed	115,200 baud
<b>Cell-Balancing Parameters</b>	
Cell-Balancing Algorithms	<ol style="list-style-type: none"> <li>During charge phase</li> <li>During discharge phase</li> </ol>
Cell-Balancing Configuration Parameters	<ul style="list-style-type: none"> <li>Cell-balance circuit resistors nominal</li> <li>Cell-balance interval parameter</li> <li>Minimum balance voltage value for charge phase</li> <li>Minimum balance voltage value for discharge phase</li> <li>Minimum charge current value when cell balancing is allowed</li> <li>Voltage value of the middle charging state for the discharge phase</li> </ul>

Item	Specification
Minimum Balance Voltage Value for Charge Phase	Equal to the voltage measurement error value (15 mV – 30 mV)
Minimum Balance Voltage Value for Discharge Phase	Equal to the voltage measurement error value (15 mV – 30 mV) plus the internal impedance error (10 mV – 30 mV)
<b>Fuel Gauge Parameters</b>	
Fuel Gauge Battery Capacity Monitoring Method	Coulomb counter-based fuel gauge
Fuel Gauge Calculation Parameters	<ul style="list-style-type: none"> <li>• Absolute capacity (ACR)</li> <li>• State of charge (SOC)</li> <li>• Runtime remaining in active mode</li> <li>• Runtime remaining in suspend mode</li> <li>• Full-charge time remaining</li> <li>• Rapid-charge time remaining</li> </ul>
Fuel Gauge Correction	<ul style="list-style-type: none"> <li>• Temperature</li> <li>• Discharge rate</li> <li>• Cell aging (fuel gauge learning charge cycle)</li> </ul>
Fuel Gauge State of Charge (SOC) Measurement Error	1-3%

**Note** <sup>1</sup> The project in this Application Note is not optimized for power consumption. This value can be greatly decreased.

## Regulator Topologies

There are two basic types of power regulators: linear regulators and switching regulators. The most popular of the switching regulator topologies are:

- Buck Converter (Step-Down Converter)
- Boost Converter (Step-Up Converter)
- Buck-Boost Converter
- Flyback Converter
- Single-Ended Primary Inductive Converter (SEPIC)

This section describes the buck, buck-boost, and SEPIC topologies because they are most frequently used in battery chargers.

## Buck Converter

The buck converter or step-down converter can only step voltage down from a higher level to a lower level. [Figure 2](#) shows a buck converter schematic.

Figure 2. Buck Converter Schematic

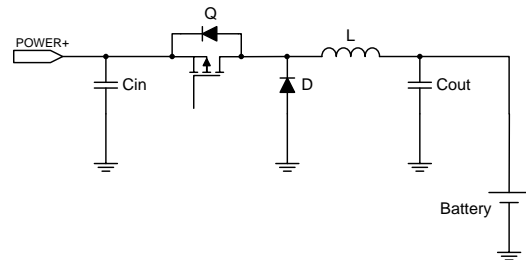

Advantages of the buck converter:

- Low complexity

Disadvantages of the buck converter:

- There is a path from the battery pack to the Power+ input through the buck switch MOSFET body diode. Therefore, an additional blocking diode in the path is needed.
- If the MOSFET ever shorts there is no way to limit the current into the battery. Therefore, an additional protection device (fuse) must be used.

## Buck-Boost Converter

Buck-boost converters produce a regulated output voltage either less than or greater than the input voltage. When the input voltage is higher than the output, the converter acts as a buck. When the input is lower than the output, the converter boosts. Figure 3 shows a buck-boost converter schematic.

Figure 3. Buck-Boost Converter Schematic

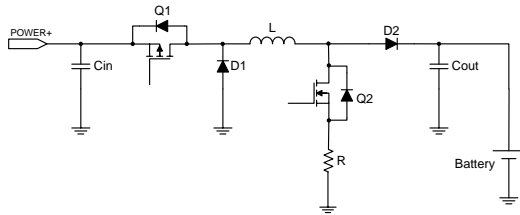

Advantages of the buck-boost converter:

- The input voltage can be less than or greater than the output voltage.
- The output stage rectifier diode is used as the reverse blocking diode.

Disadvantages of the buck-boost converter:

- If the MOSFET ever shorts there is no way to limit the current into the battery (similar to the buck converter).
- Two switches and two diodes are needed so that the output power is not inverted.

## SEPIC

The Single-Ended Primary Inductive Converter (SEPIC) uses a two-winding inductor and a coupling capacitor to store and transfer energy. Figure 4 illustrates the SEPIC schematic.

Figure 4. SEPIC Schematic

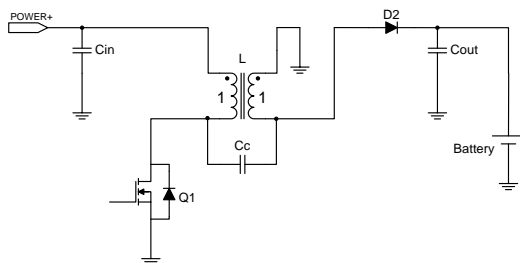

Advantages of the SEPIC:

- The input voltage can be less than or greater than the output voltage.
- It has good capacitive primary-to-secondary isolation.
- The output stage rectifier diode is used as a reverse blocking diode.

- It uses only a single switch.
- If switch Q1 shorts, the input voltage power supply is shorted as well and the battery pack is disconnected from the external power supply (in contrast to buck and buck-boost converters).

Disadvantages of the SEPIC:

- It has higher switch/diode peak voltages and currents compared to the other topologies.
- Two external components, an inductor with two windings and coupling capacitor, are needed.

In this application, the technical advantages of the SEPIC outweigh the disadvantages. If you need a battery charger with only step-down capability, the simple buck converter (step-down regulator) is preferred.

## Device Schematic

This Application Note uses the device structure, battery pack parameter measurement techniques, and PSoC internal structure from, “Cell Balancing in a Multi-Cell Li-Ion/Li-Pol Battery Charger.” The temperature measurement technique used is the one explained in AN2314, “Thermistor-Based Temperature Measuring in Battery Packs.”

Figure 5 and Figure 6 show the complete multi-cell battery charger schematic.

A signal from the pulse width modulator PWM\_DRIVE goes to the high-speed MOSFET driver U1. This driver chip provides MOSFET Q1 with high slew rate regulation from the low current PWM\_DRIVE signal. The PWM\_DRIVE switch frequency was set close to 100 kHz. When switch Q1 is turned on, the current through the inductor L1 will ramp up at a rate of  $V_{in}/L1$ . When the inductor L1=L2 is coupled, the current through the inductor L2 will ramp at the same rate. Therefore, the switch current Q1 is equal to the sum of the inductor currents while the switch is on. The input current in the SEPIC is continuous. When switch Q1 turns off, the path for current is from the input through the inductor L1 and the coupling capacitors (C8, C10, C12-C14) to the output. Another path for current flow exists through inductor L2 to the output. Therefore, the sum of L1 and L2 currents flow to the output. This output current also replenishes the output capacitors (C3-C6) while the switch is off. The output capacitors provide the output current flow while the switch is on. This smooths the output current pulses from the SEPIC.

The cell-balancing circuit is represented by MOSFETs Q2-Q5 and balancing resistors R8, R12, R15, R20. The resistors R9, R13, R17, capacitors C15, C17, C21, and diodes D5-D7 allow a TTL signal from the PWM\_BAL to control the MOSFETs Q2-Q4. The lower transistor Q5 is directly controlled by the PSoC device port; a high level turns it on, low level turns it off.

The resistive network (R5, R7, R10, R11, R14, R16, R18, R19, R21, R22, R24-R27, R30) and the reference voltage Vbias from the divider on R36 and D13 changes the battery current, voltage, and temperature signals to levels that are suitable for the PSoC device. The 100 mΩ resistor R29 is a current-sense resistor that is in the battery pack current path.

The multi-cell charger user interface uses two buttons, SW1 and SW2, to control some of the process and two LEDs to display internal status:

- Green LED lit – Charge phase
- Yellow LED lit – Discharge phase
- Both LEDs lit – Error state
- Both LEDs off – Idle state

SW1 is used to turn the device on and off. Switch SW2 is used for test purposes. Holding switch SW1 on and pressing switch SW2 allows you to choose the number of batteries connected in series in the battery pack. The result is shown on the LEDs and on the PC software. The result is also stored to the internal Flash memory of the PSoC device.

Linear regulator U3 provides the processor power supply from a higher level voltage. As an alternative, you can use a regulated step-down converter from the internal switch mode pump (SMP) as shown in AN2180, “Using the PSoC Switch Mode Pump in a Step-Down Converter.” To use this device as a battery pack management system you should use a switching regulator with very little power consumption. An external voltage supply is applied to the connector J4. Switch SW3 allows the device to be disconnected from the external power supply. Two diodes in the diode array D10 allow the processor to operate during the charge phase from the external power supply and during the discharge phase from the battery pack power supply.

The external load is connected to the connector J3 LOAD. The diodes D8 and D9 are used to provide an uninterruptible power supply for the LOAD connector in a manner that is similar to that of D10 for the processor. The switch on transistors Q6 and Q7 allow the power supply to be disconnected from the LOAD to protect the battery from deep discharge. This switch is optional and can be removed to reduce total device cost. Often, deep discharge protection is implemented in the batteries themselves by means of a dedicated protection IC. The board ground level is set to the external ground level POWER- before the current-sense resistor. As a result, only the charge battery pack current and the total battery pack discharge current are passed through the current-sense resistor. These are used to supplement the battery fuel gauge function in the PSoC software.

The user module placement and internal connectivity of the PSoC device are shown in Figure 7. The PWM\_BAL is configured on the clock source from CPU 32 kHz (internal low speed oscillator). This gives the PWM\_BAL user module the ability to work during processor sleep mode. The rest of the configuration is very similar.

Figure 5. Multi-Cell Battery Charger Schematic – CPU, Cell Balancing, and Measuring Equipment

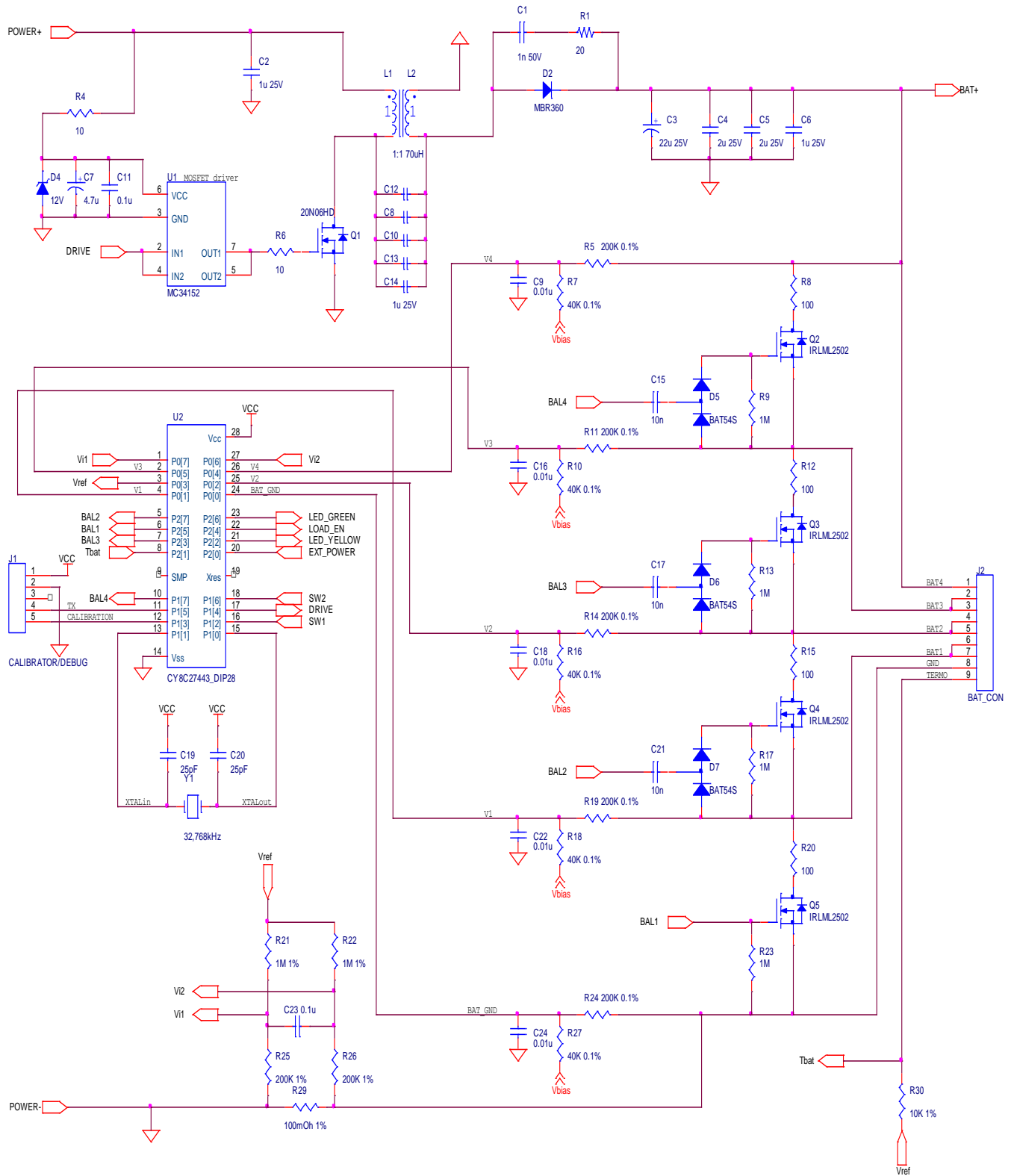

Figure 6. Multi-Cell Battery Charger Schematic – Power Supply and User Interface

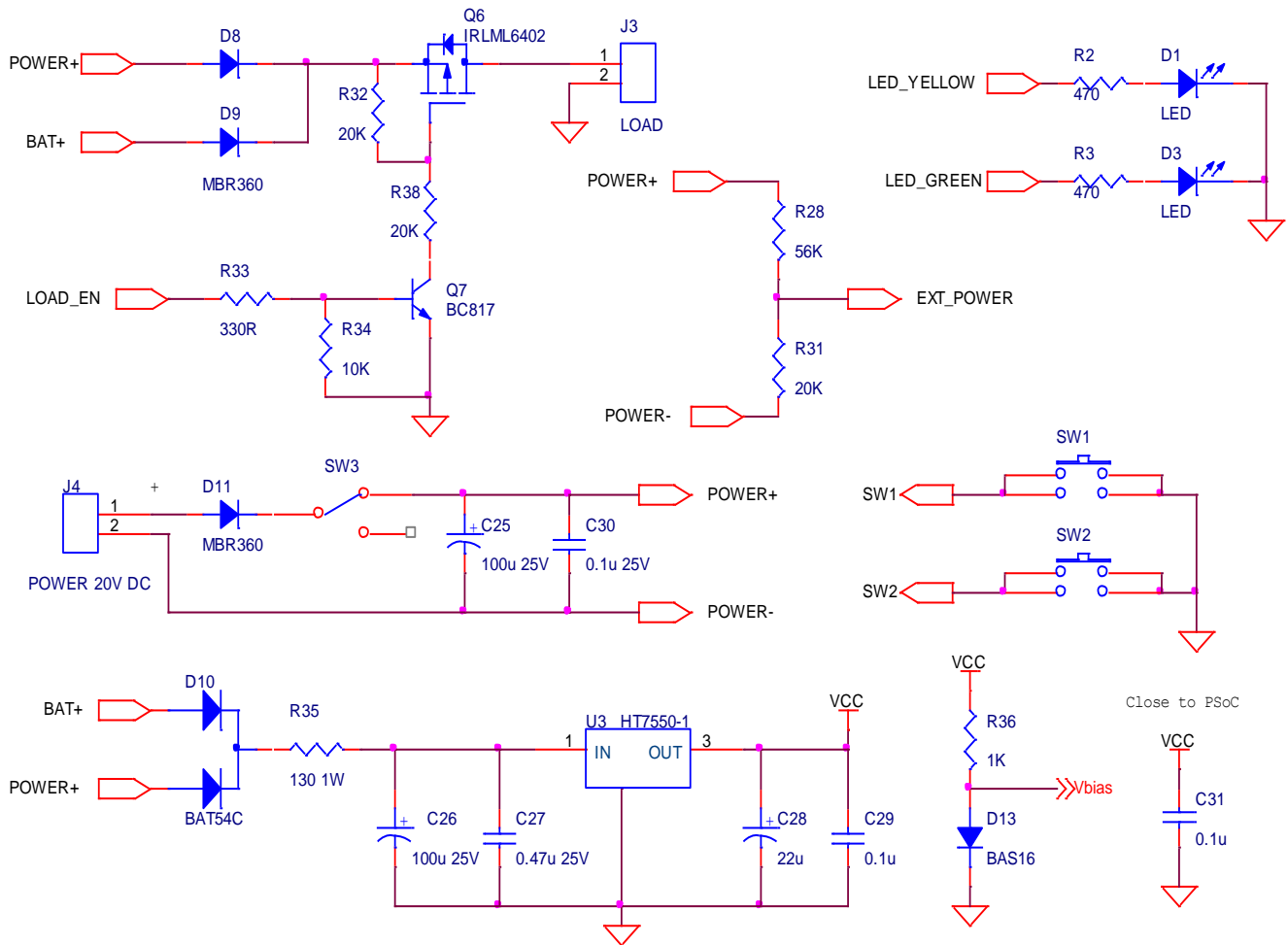
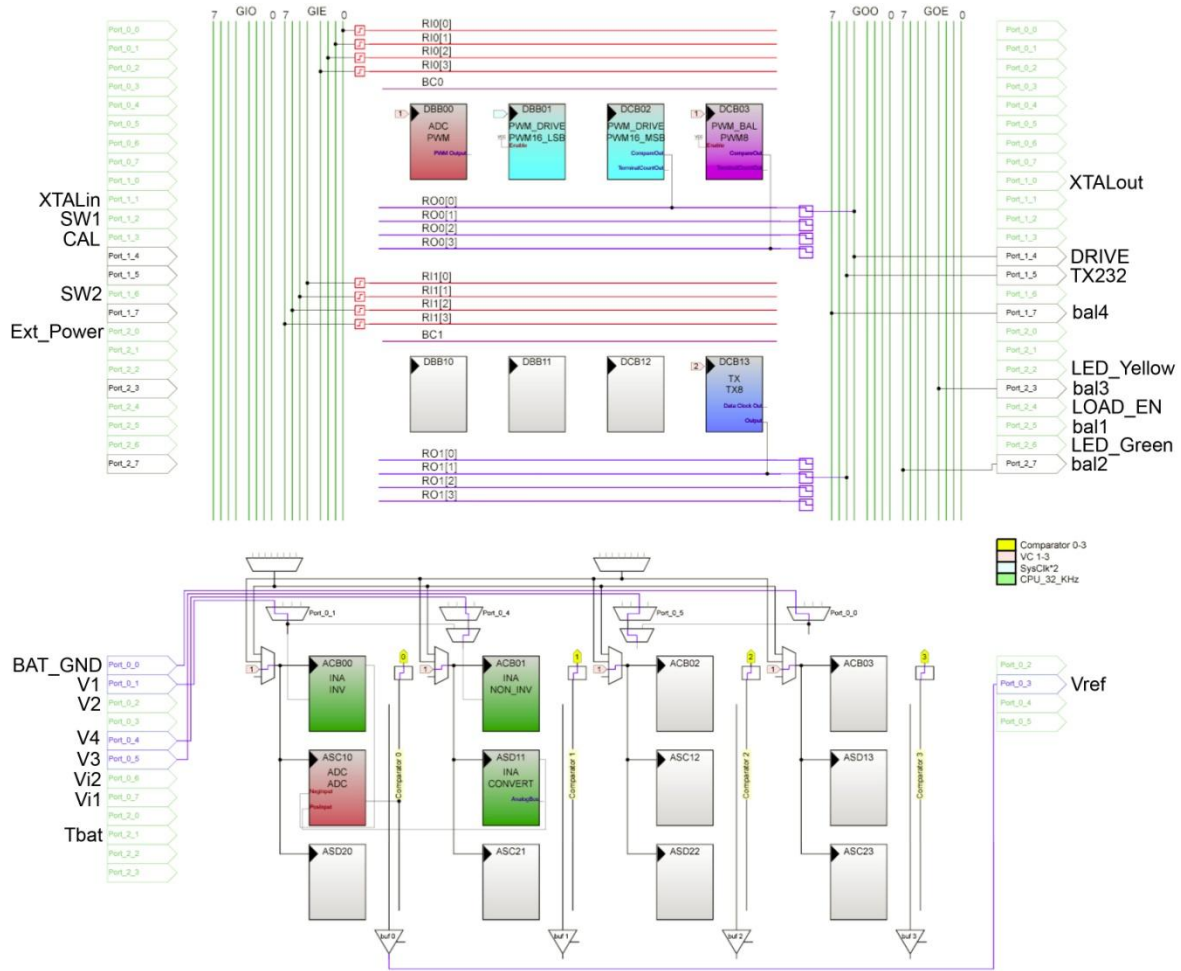

Figure 7. Internal User Module Placement and Configuration





## Multi-Cell Battery Charger Firmware

The multi-cell battery charger firmware is separated into several modules that serve distinct functions:

- Performing measurements
- Regulating the battery charge process and timer functions
- Performing the Li-Ion or Li-Pol battery charging algorithm
- Checking the charge termination conditions
- Performing fuel gauge and cell-balance algorithms
- Storing calibration settings to the PSoC device Flash memory
- Transmitting debug data

## Conclusion

This multi-cell Li-Ion/Li-Pol battery charger with cell-balancing and fuel gauge technology supports single cell batteries or battery packs with two, three, or four Li-Ion or Li-Pol cells in series. It allows you to use an external supply with a wide voltage range either less than or greater than the battery pack voltage.

It provides dedicated PC-based software for real-time viewing and analysis of the charge, cell-balance and fuel gauge processes.

The unique architecture of the PSoC device provides an integrated hardware solution for a multi-cell battery charger with flexible microcontroller-based, cell-balance and fuel gauge algorithms requiring minimal external components at a very affordable price. The device can be used as a complete battery pack management system for notebooks, medical and industrial equipment, and other, similar applications.

Figure 8. Multi-Cell Battery Charger Photograph

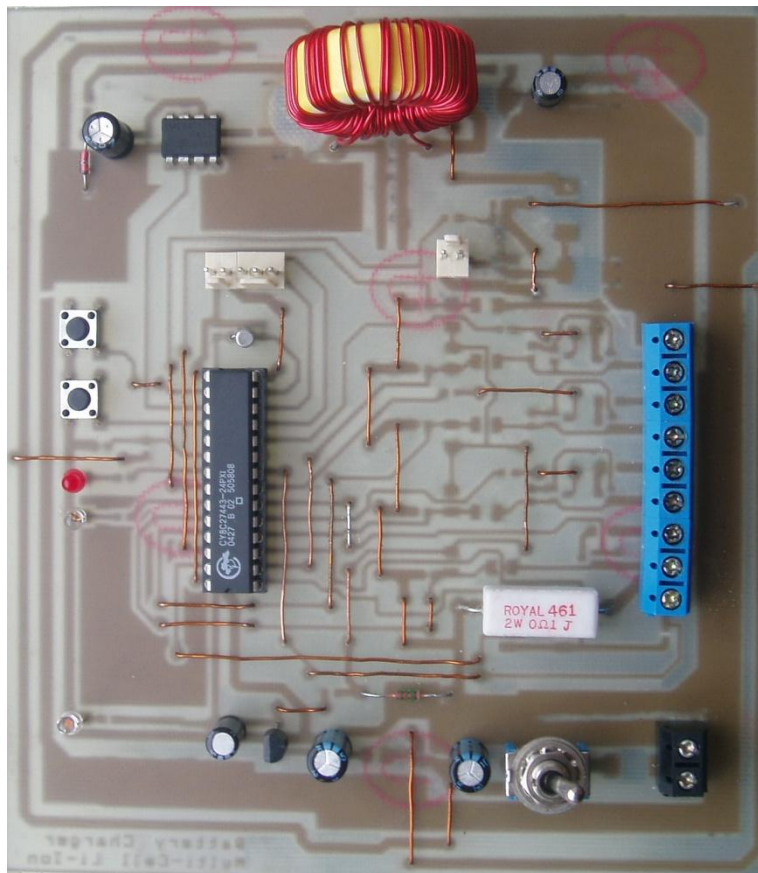

## Appendix A: Charge, Discharge, Cell-Balance and Fuel Gauge Profile Examples

Figure 9. Charge and Discharge Manager Profile

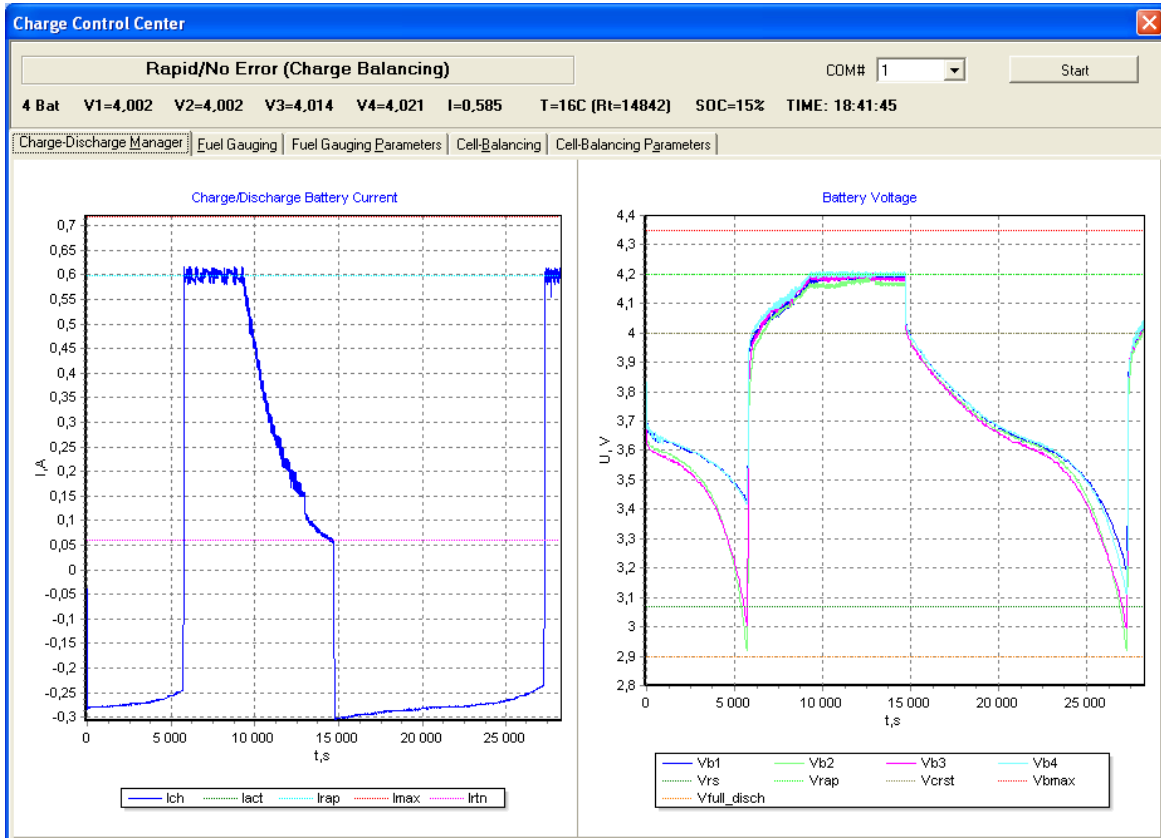

Figure 10. Fuel Gauge Information Profile

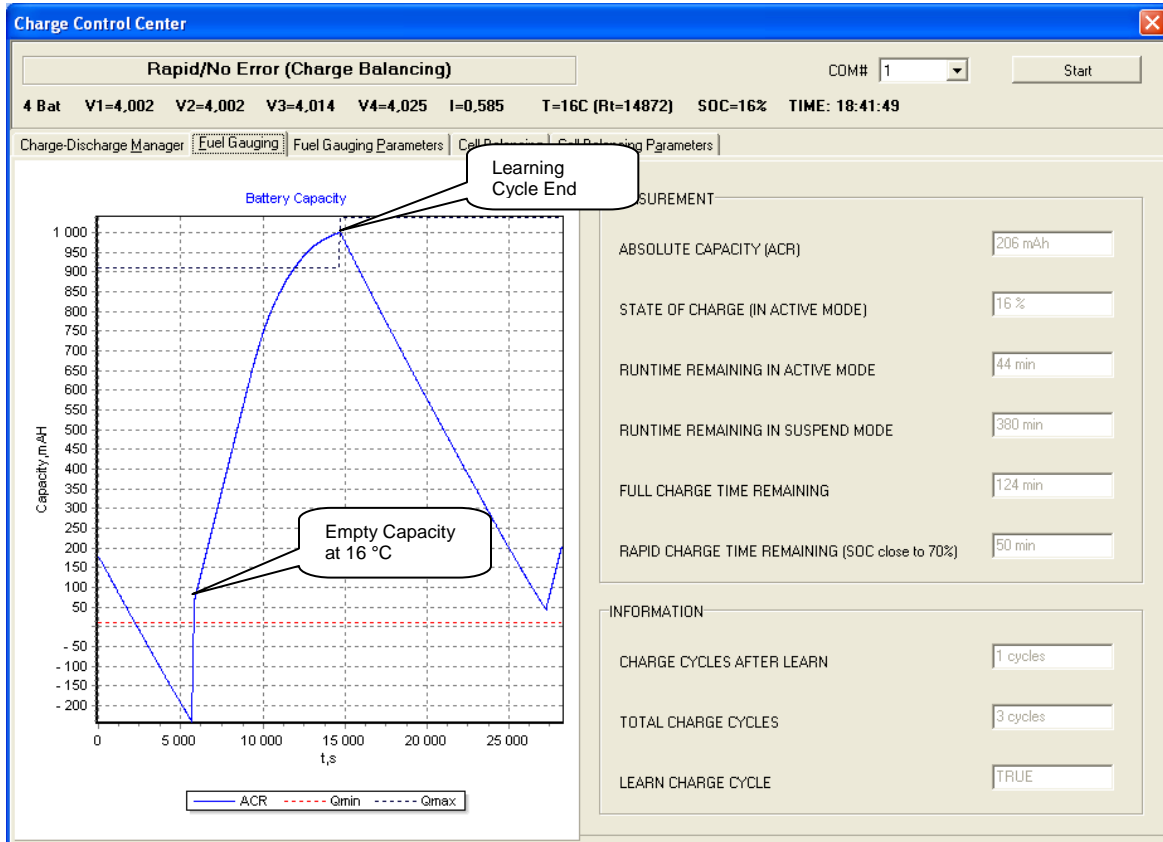
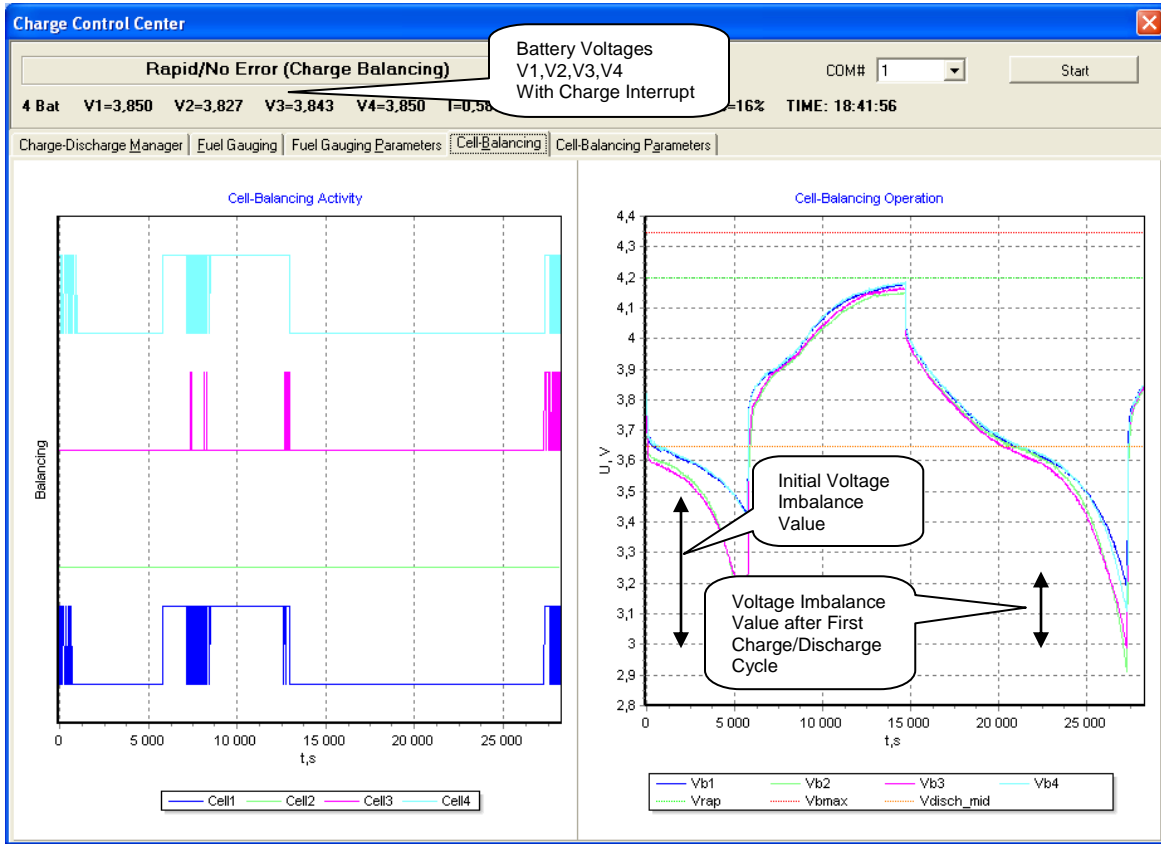

Figure 11. Cell-Balancing Activity Profile



## Document History

Document Title: AN2344 – Power Management - Battery Charger with Cell-Balancing and Fuel Gauge Function Support

Document Number: 001-15223

Revision	ECN	Orig. of Change	Submission Date	Description of Change
**	1034485	YARD_UKR	05/02/2007	Added new spec
*A	3285106	ANBI_UKR	06/16/2011	Updated to latest PSoC Designer. Updated document to new template.
*B	4429522	RJVB	07/03/2014	Updated template.
*C	5713494	AESATMP9	04/26/2017	Updated logo and copyright.

## Worldwide Sales and Design Support

Cypress maintains a worldwide network of offices, solution centers, manufacturer's representatives, and distributors. To find the office closest to you, visit us at [Cypress Locations](#).

### Products

ARM® Cortex® Microcontrollers	<a href="http://cypress.com/arm">cypress.com/arm</a>
Automotive	<a href="http://cypress.com/automotive">cypress.com/automotive</a>
Clocks & Buffers	<a href="http://cypress.com/clocks">cypress.com/clocks</a>
Interface	<a href="http://cypress.com/interface">cypress.com/interface</a>
Internet of Things	<a href="http://cypress.com/iot">cypress.com/iot</a>
Memory	<a href="http://cypress.com/memory">cypress.com/memory</a>
Microcontrollers	<a href="http://cypress.com/mcu">cypress.com/mcu</a>
PSoC	<a href="http://cypress.com/psoc">cypress.com/psoc</a>
Power Management ICs	<a href="http://cypress.com/pmic">cypress.com/pmic</a>
Touch Sensing	<a href="http://cypress.com/touch">cypress.com/touch</a>
USB Controllers	<a href="http://cypress.com/usb">cypress.com/usb</a>
Wireless Connectivity	<a href="http://cypress.com/wireless">cypress.com/wireless</a>

### PSoC® Solutions

[PSoC 1](#) | [PSoC 3](#) | [PSoC 4](#) | [PSoC 5LP](#) | [PSoC 6](#)

### Cypress Developer Community

[Forums](#) | [WICED IOT Forums](#) | [Projects](#) | [Videos](#) | [Blogs](#) | [Training](#) | [Components](#)

### Technical Support

[cypress.com/support](http://cypress.com/support)

All other trademarks or registered trademarks referenced herein are the property of their respective owners.



Cypress Semiconductor  
198 Champion Court  
San Jose, CA 95134-1709

©Cypress Semiconductor Corporation, 2007-2017. This document is the property of Cypress Semiconductor Corporation and its subsidiaries, including Spanion LLC ("Cypress"). This document, including any software or firmware included or referenced in this document ("Software"), is owned by Cypress under the intellectual property laws and treaties of the United States and other countries worldwide. Cypress reserves all rights under such laws and treaties and does not, except as specifically stated in this paragraph, grant any license under its patents, copyrights, trademarks, or other intellectual property rights. If the Software is not accompanied by a license agreement and you do not otherwise have a written agreement with Cypress governing the use of the Software, then Cypress hereby grants you a personal, non-exclusive, nontransferable license (without the right to sublicense) (1) under its copyright rights in the Software (a) for Software provided in source code form, to modify and reproduce the Software solely for use with Cypress hardware products, only internally within your organization, and (b) to distribute the Software in binary code form externally to end users (either directly or indirectly through resellers and distributors), solely for use on Cypress hardware product units, and (2) under those claims of Cypress's patents that are infringed by the Software (as provided by Cypress, unmodified) to make, use, distribute, and import the Software solely for use with Cypress hardware products. Any other use, reproduction, modification, translation, or compilation of the Software is prohibited.

TO THE EXTENT PERMITTED BY APPLICABLE LAW, CYPRESS MAKES NO WARRANTY OF ANY KIND, EXPRESS OR IMPLIED, WITH REGARD TO THIS DOCUMENT OR ANY SOFTWARE OR ACCOMPANYING HARDWARE, INCLUDING, BUT NOT LIMITED TO, THE IMPLIED WARRANTIES OF MERCHANTABILITY AND FITNESS FOR A PARTICULAR PURPOSE. To the extent permitted by applicable law, Cypress reserves the right to make changes to this document without further notice. Cypress does not assume any liability arising out of the application or use of any product or circuit described in this document. Any information provided in this document, including any sample design information or programming code, is provided only for reference purposes. It is the responsibility of the user of this document to properly design, program, and test the functionality and safety of any application made of this information and any resulting product. Cypress products are not designed, intended, or authorized for use as critical components in systems designed or intended for the operation of weapons, weapons systems, nuclear installations, life-support devices or systems, other medical devices or systems (including resuscitation equipment and surgical implants), pollution control or hazardous substances management, or other uses where the failure of the device or system could cause personal injury, death, or property damage ("Unintended Uses"). A critical component is any component of a device or system whose failure to perform can be reasonably expected to cause the failure of the device or system, or to affect its safety or effectiveness. Cypress is not liable, in whole or in part, and you shall and hereby do release Cypress from any claim, damage, or other liability arising from or related to all Unintended Uses of Cypress products. You shall indemnify and hold Cypress harmless from and against all claims, costs, damages, and other liabilities, including claims for personal injury or death, arising from or related to any Unintended Uses of Cypress products.

Cypress, the Cypress logo, Spanion, the Spanion logo, and combinations thereof, WICED, PSoC, CapSense, EZ-USB, F-RAM, and Traveo are trademarks or registered trademarks of Cypress in the United States and other countries. For a more complete list of Cypress trademarks, visit [cypress.com](http://cypress.com). Other names and brands may be claimed as property of their respective owners.