

# Getting Started with the Traveo Family S6J3110 Series

## About this document

### Scope and purpose

AN203911 describes the development tools available for the Traveo™ Family S6J3110 Series.

### Associated Part Family

[Traveo Family S6J3110 Series](#)

## Table of contents

<b>About this document</b> .....	<b>1</b>
<b>Table of contents</b> .....	<b>1</b>
<b>1 Introduction</b> .....	<b>2</b>
<b>2 Traveo™ Family S6J3110 series feature set</b> .....	<b>3</b>
<b>3 Development environment and tools</b> .....	<b>4</b>
3.1 Evaluation board .....	4
3.2 Sample software.....	4
3.3 Debugging tools .....	5
<b>4 Connection diagram and operation mode</b> .....	<b>6</b>
<b>5 Summary</b> .....	<b>7</b>
<b>6 Related documents</b> .....	<b>8</b>
<b>Revision history</b> .....	<b>9</b>

---

## Introduction

### 1 Introduction

This application note describes the development environment and tools for the Traveo™ Family S6J3110 Series. This series includes an ARM Cortex-R5 CPU core, Secure Hardware Extension (SHE), CAN FD, memory, and analog and digital peripheral functions in a single chip supplied by a 5-V single power supply. The product lineup of the S6J3110 series features 176-pin and 144-pin packages and memory size variations. Refer to the [fact sheet](#) and [data sheet](#) for more details.

## Traveo™ Family S6J3110 series feature set

### 2 Traveo™ Family S6J3110 series feature set

The Traveo™ S6J3110 Series features a single ARM Cortex-R5. The S6J3110 incorporates the high-performance CAN FD interface for enhanced in-vehicle networking and is focused on various automotive applications.

**Figure 1** shows many peripheral resources.

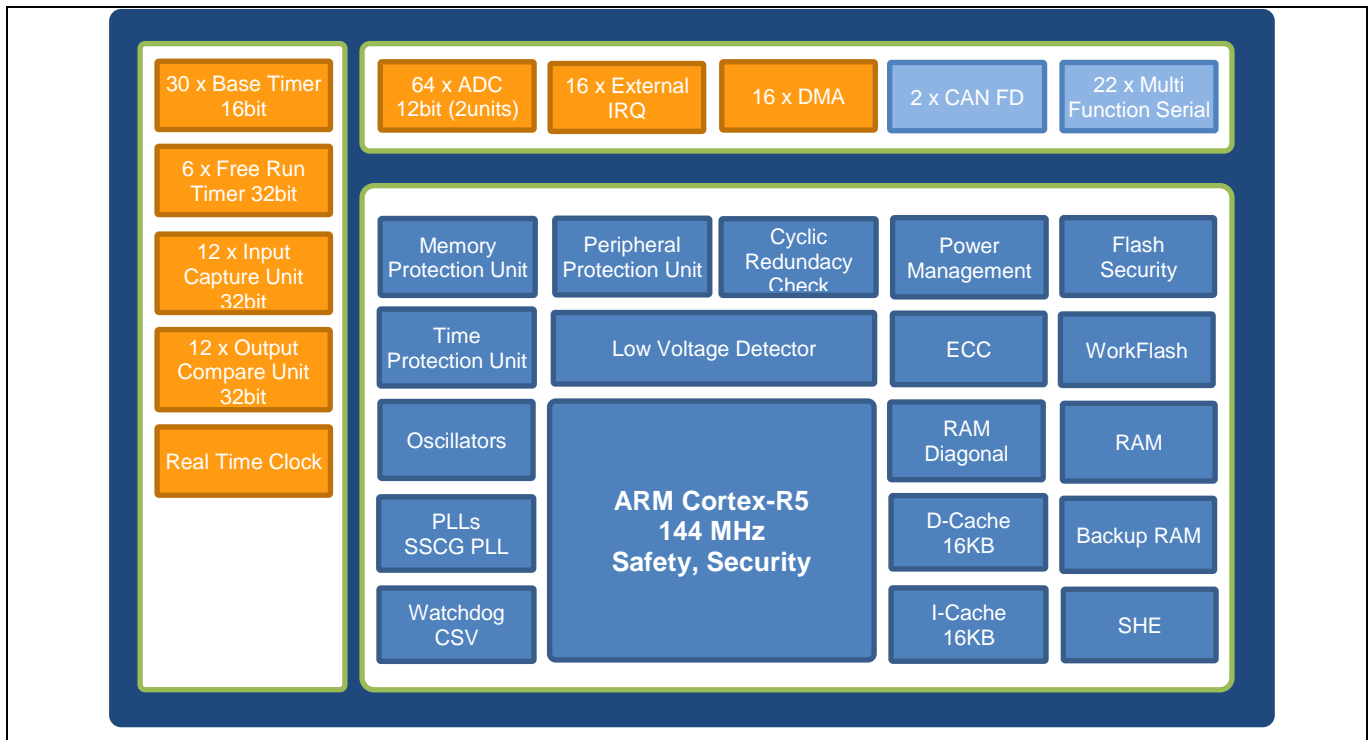

**Figure 1** Traveo™ Family S6J3110 series block diagram

Below is a list of major features of the S6J3110 series. For more information, see the [related documents](#).

#### Features:

- Up to 144MHz ARM® Cortex®-R5 core
- Including a DMA controller and a SHE (Secure Hardware Extension) for encryption engine.
- Including Flash memory for code and data, and System SRAM, Backup RAM, and TCRAM.  
Flash memory for program code: up to 4MB, for work data: up to 112KB.  
System SRAM: up to 256KB, Backup RAM: up to 64KB, TCRAM: 64KB.
- 12-bits A/D Converter, CAN FD, several Timers, MFS (Lin, UART, CSIO, I<sup>2</sup>C) and peripheral functions included.
- JTAG I/F for debug and programming user programs are included.

## Development environment and tools

### 3 Development environment and tools

#### 3.1 Evaluation board

Cypress provides a wealth of evaluation boards to help you get started using an MCU. The S6J3110 series evaluation board works alone, but it also connects to a main board. The main board is common use to the FR81S Family products and F<sup>2</sup>MC-16FX Family MB96600 Series. This board has useful ports including LIN, CAN, UART, and more.

Contact your sales representative or [Cypress Technical Support](#), if you want to buy the evaluation board.

**Table 1** lists the current available part numbers for the S6J3110 series evaluation boards. **Table 2** lists the main board.

**Table 1 S6J3110 series evaluation boards**

Part number	S6T3J300111A176A2	S6T3J300112A144A2	S6T3J300113A144A2
<b>Description</b>	Evaluation board for S6J311EJAB mounted	Evaluation board for S6J311EHAB mounted	Evaluation board for S6J311AHAB mounted
<b>Pins</b>	176	144	144
<b>CAN FD port</b>	2ch	1ch	1ch
<b>LIN port</b>	1ch	1ch	1ch
<b>UART port</b>	1ch	1ch	1ch
<b>Debug port</b>	JTAG Arm 20	JTAG Arm 20	JTAG Arm 20
<b>Switches</b>	RESET, NMI, INT	RESET, NMI, INT	RESET, NMI, INT

**Table 2 Evaluation board (main board)**

Part number	MB2198-760-E
<b>Description</b>	MCU Evaluation board (main board) Connect to the S6J3110 Series evaluation board and F <sup>2</sup> MC-16FX/FR Family board
<b>Connector</b>	LIN I/F 2ch, CAN I/F 2ch, RS I/F 2ch, USB
<b>Switches</b>	Reset, NMI, INT

For more information for main board, see the [operation manual](#).

#### 3.2 Sample software

Contact your sales representative or [Cypress Technical Support](#), if you want to use the sample software.

## Development environment and tools

### 3.3 Debugging tools

Debugging tools are provided by third parties, as listed in [Table 3](#) Cypress provides sample software (template project and sample driver) for each tool. The template project includes IO header files, startup setting, and some sample sources. It is very helpful to start using the S6J3110 series with the evaluation board and tools. The sample driver includes some sources for peripheral features of the S6J3110 series.

*Note: Cypress software such as AUTOSAR is designed for using with MULTI of Green Hills software.*

**Table 3 Debugging tools**

Vendor	Software (Integrated development environment)	Hardware (Debugging tools)
Green Hills software	MULTI v2013.5.4 or later	Green Hills probe
IAR systems	IAR Embedded Workbench for Arm (EWArm) v7.30.4 or later	I-jet

Connection diagram and operation mode

### 4 Connection diagram and operation mode

The S6J3110 series has JTAG ports to connect with a debugging tool, but the nSRST JTAG port is not supported in this series. Therefore, nSRST should be connected to the RSTX port of this product, if needed. **Figure 2** shows a basic connection diagram for S6J311EJ.

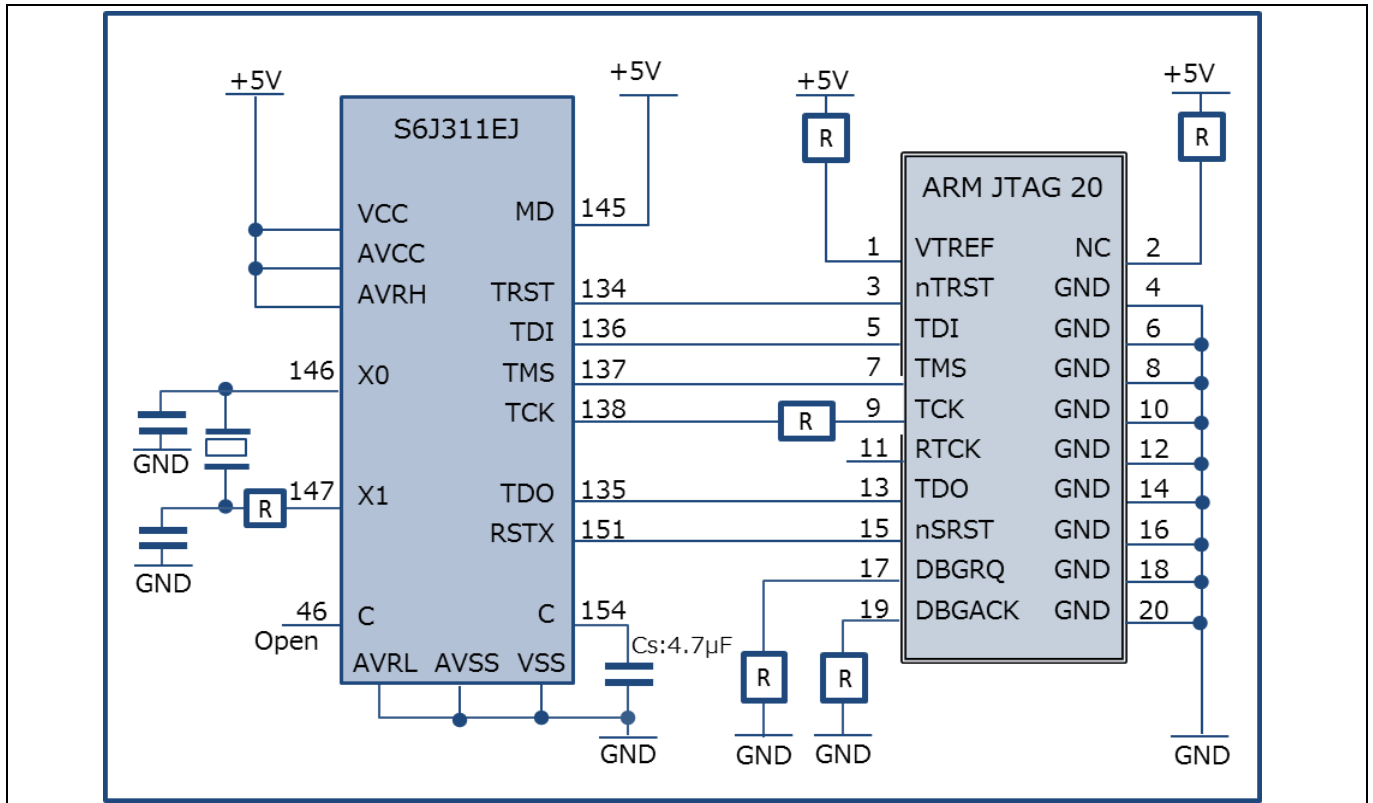

**Figure 2 S6J311EJ basic connection diagram with Arm JTAG 20**

The S6J3110 series has a User mode and Serial Write modes. **Figure 2** shows the User mode connection. The Serial Write modes use P020 and P022 with the MD port. **Table 4** lists the operation modes combined with the MD, P020, and P022 ports.

Serial Write mode (sync, async) supports writing a user program to the flash memory included in the MCU through the UART connection. The PC and target MCU are connected via a serial cable. Cypress provides flash program software that works on the PC, and both the main and sub evaluation boards have a UART port. Contact your sales representative or **Cypress Technical Support**, if you want to evaluate the flash program software.

In addition, a flash memory programmer provided by Yokogawa Digital Computer (YDC) supports writing a user program to the flash memory using a serial port in the S6J3110 series.

**Table 4 Operation mode**

Operation mode	MD pin	P020	P022
User mode	1	-	-
Serial Write mode (Sync)	0	1	0
Serial Write mode (Async)	0	1	1

---

## Summary

### 5 Summary

Cypress provides a wealth of evaluation boards and sample software to help you to get started with Traveo. To evaluate S6J3110 series evaluation boards, contact your sales representative or [Cypress Technical Support](#).

---

## Related documents

### 6 Related documents

- [S6J3110 Series 32-bit Microcontroller Traveo Family Fact Sheet](#)
- [S6J3110 Series 32-bit Microcontroller Traveo Family Data Sheet](#)
- S6J3110 Series 32-bit Microcontroller Traveo Family Hardware Manual (Contact [Technical Support](#))



---

## Revision history

### Revision history

Document version	Date of release	Description of changes
**	2016-05-20	New application note.
*A	2017-08-01	Updated Cypress Logo and Copyright.
*B	2021-06-15	Updated to Infineon template.

#### **Trademarks**

All referenced product or service names and trademarks are the property of their respective owners.

**Edition 2021-06-15**

**Published by**

**Infineon Technologies AG**

**81726 Munich, Germany**

**© 2021 Infineon Technologies AG.**

**All Rights Reserved.**

**Do you have a question about this document?**

**Go to [www.cypress.com/support](http://www.cypress.com/support)**

**Document reference**

**002-03911 Rev. \*B**

#### **IMPORTANT NOTICE**

The information contained in this application note is given as a hint for the implementation of the product only and shall in no event be regarded as a description or warranty of a certain functionality, condition or quality of the product. Before implementation of the product, the recipient of this application note must verify any function and other technical information given herein in the real application. Infineon Technologies hereby disclaims any and all warranties and liabilities of any kind (including without limitation warranties of non-infringement of intellectual property rights of any third party) with respect to any and all information given in this application note.

The data contained in this document is exclusively intended for technically trained staff. It is the responsibility of customer's technical departments to evaluate the suitability of the product for the intended application and the completeness of the product information given in this document with respect to such application.

For further information on the product, technology, delivery terms and conditions and prices please contact your nearest Infineon Technologies office ([www.infineon.com](http://www.infineon.com)).

#### **WARNINGS**

Due to technical requirements products may contain dangerous substances. For information on the types in question please contact your nearest Infineon Technologies office.

Except as otherwise explicitly approved by Infineon Technologies in a written document signed by authorized representatives of Infineon Technologies, Infineon Technologies' products may not be used in any applications where a failure of the product or any consequences of the use thereof can reasonably be expected to result in personal injury.