

AN2012-04 MA3L120E07_EVAL
Evaluation Adapter Board for EconoPACK™ 4 3-Level
Modules in NPC2-Topology

Edition 2011-05-15
Published by
Infineon Technologies AG
59568 Warstein, Germany
© Infineon Technologies AG 2011.
All Rights Reserved.

Attention please!

THE INFORMATION GIVEN IN THIS APPLICATION NOTE IS GIVEN AS A HINT FOR THE IMPLEMENTATION OF THE INFINEON TECHNOLOGIES COMPONENT ONLY AND SHALL NOT BE REGARDED AS ANY DESCRIPTION OR WARRANTY OF A CERTAIN FUNCTIONALITY, CONDITION OR QUALITY OF THE INFINEON TECHNOLOGIES COMPONENT. THE RECIPIENT OF THIS APPLICATION NOTE MUST VERIFY ANY FUNCTION DESCRIBED HEREIN IN THE REAL APPLICATION. INFINEON TECHNOLOGIES HEREBY DISCLAIMS ANY AND ALL WARRANTIES AND LIABILITIES OF ANY KIND (INCLUDING WITHOUT LIMITATION WARRANTIES OF NON-INFRINGEMENT OF INTELLECTUAL PROPERTY RIGHTS OF ANY THIRD PARTY) WITH RESPECT TO ANY AND ALL INFORMATION GIVEN IN THIS APPLICATION NOTE.

Information

For further information on technology, delivery terms and conditions and prices please contact your nearest Infineon Technologies Office (www.infineon.com).

Warnings

Due to technical requirements components may contain dangerous substances. For information on the types in question please contact your nearest Infineon Technologies Office. Infineon Technologies Components may only be used in life-support devices or systems with the express written approval of Infineon Technologies, if a failure of such components can reasonably be expected to cause the failure of that life-support device or system, or to affect the safety or effectiveness of that device or system. Life support devices or systems are intended to be implanted in the human body, or to support and/or maintain and sustain and/or protect human life. If they fail, it is reasonable to assume that the health of the user or other persons may be endangered.

AN 2012-04

Revision History: date (2012-04-15), V1.0

Previous Version: none

Subjects: none

Authors: A. S.

We Listen to Your Comments

Any information within this document that you feel is wrong, unclear or missing at all? Your feedback will help us to continuously improve the quality of this document. Please send your proposal (including a reference to this document) to: [\[WAR-IGBT-Application@infineon.com\]](mailto:WAR-IGBT-Application@infineon.com)

1	Introduction.....	4
1.1	Part Number explanation	4
2	Design features.....	5
2.1	Main features	5
2.2	Key Data	5
2.3	Mechanical dimensions.....	6
3	Pin assignments	7
4	Functionality of the board	8
4.1	Power supply.....	8
4.2	Booster.....	9
4.3	VCE monitoring for short circuit detection	10
4.4	Active clamping function	10
4.5	Maximum switching frequency.....	10
5	Paralleling.....	12
5.1	Static current imbalance	12
5.2	Dynamic current imbalance	12
5.3	Paralleling with MA3L120E07_EVAL.....	12
6	Schematics and Layouts	14
6.1	Schematics.....	14
6.2	Layouts.....	16
7	Bill of Material of MA3L120E07_EVAL.....	18
8	How to order the Evaluation Adapter Board.....	19
9	Literature	19



The board described is an evaluation board dedicated for laboratory environment only. It operates at high voltages. This board must be operated by qualified and skilled personnel familiar with all applicable safety standards.

1 Introduction

The evaluation adapter board MA3L120E07_EVAL for 3-level NPC2 EconoPACK™ 4 modules as shown in Figure 1 was developed to support customers during their first steps designing applications with EconoPACK™ 4 3-level NPC2 modules. This evaluation board was designed in addition to the module driver board F3L2020E07-F-P_EVAL¹ [1] or could be a complementary part for an existing customer driver solution. For more details about the 3-level topology, please refer to [2].

The board is available from Infineon in small quantities. The properties of this part are described in the design features chapter of this document, whereas the remaining paragraphs provide information to enable the customers to copy, modify and qualify the design for production, according to their own specific requirements.

Environmental conditions were considered in the design of the MA3L120E07_EVAL. Components qualified for a lead-free reflow soldering process were selected. The design was tested as described in this document but not qualified regarding manufacturing and operation over the whole operating temperature range or lifetime.

The boards provided by Infineon are subject to functional testing only.

Due to their purpose evaluation boards are not subject to the same procedures regarding Returned Material Analysis (RMA), Process Change Notification (PCN) and Product Discontinuation (PD) as regular products.

See Legal Disclaimer and Warnings for further restrictions on Infineon's warranty and liability.



Figure 1: The evaluation adapter board MA3L120E07_EVAL for EconoPACK™ 4 3-level modules

1.1 Part Number explanation

Part number explanation:

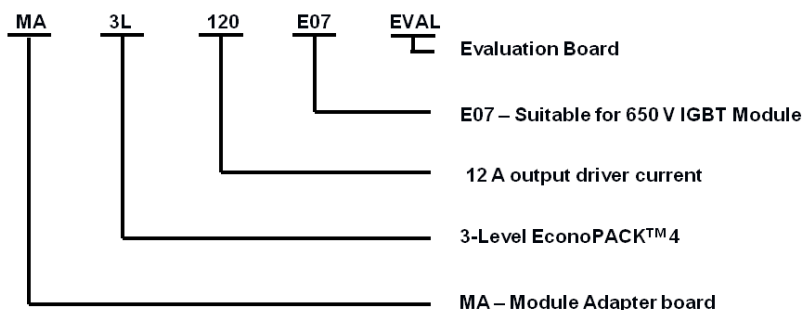

¹ Evaluation Driver Board for 3-Level EconoPACK™ 4 AN2012-03 [2]

2 Design features

Electrical features of the evaluation board and mechanical dimensions including necessary interface connections are presented in the following sections.

2.1 Main features

The evaluation board is developed to work in combination with the F3L2020E07-F-P_EVAL driver board². The MA3L120E07 adapter board provides following features:

- Electrically and mechanically suitable for 3-level NPC2 EconoPACK™4 module family
- Different gate resistor values for turning-on and -off are possible
- Active clamping protection for all IGBTs
- Desaturation output signals for short circuit monitoring
- Suitable for -8V/+15V or up to $\pm 20V$ ³

2.2 Key Data

All values given in Table 1 are typical values, measured at an ambient temperature of $T_{amb} = 25\text{ }^{\circ}\text{C}$.

Table 1: General key data and characteristic values

Parameter	Description	Value	Unit
V_{DC}	maximum DC supply voltage	± 20	V
I_G	continuous output current	± 12	A
f_s	maximum PWM signal frequency	60	kHz
T_{op}	operating temperature (design target)	-40...+85	$^{\circ}\text{C}$
T_{stg}	storage temperature (design target)	-40...+85	$^{\circ}\text{C}$

The EconoPACK™4 3-level IGBT module has two vertically and two horizontally aligned IGBTs. As a reference, Figure 2 presents the positions of the semiconductors with their designation used throughout this document.

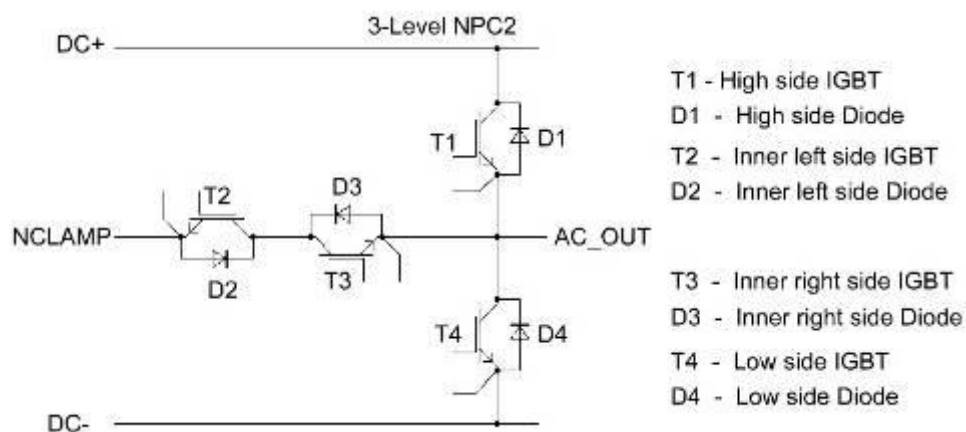
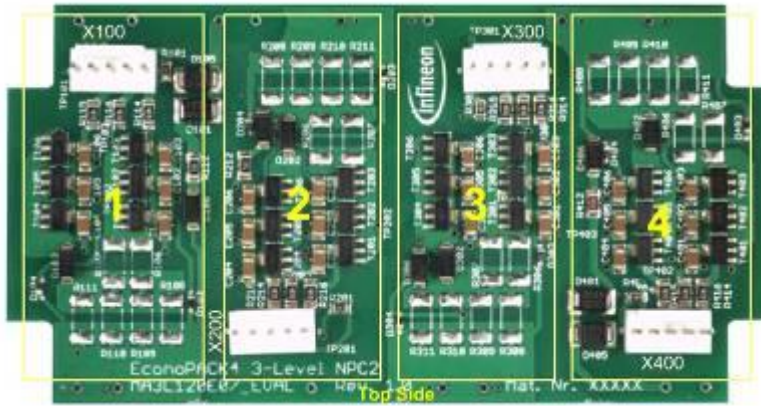

Figure 2: IGBT module with the designation of each IGBT

² Evaluation Driver Board for 3-Level NPC2 EconoPACK™4 (AN2012-03)

³ Due to IGBT short circuit performance a maximum value of $V_{GE} \sim 15V$ is recommended.

Figure 3 shows the functional groups of the MA3L120E07 evaluation board top side.



- 1: Booster for high side IGBT
- 2: Booster for inner left side IGBT
- 3: Booster for inner right side IGBT
- 4: Booster for low side IGBT

Figure 3: Functional groups of the evaluation board MA3L120E07_EVAL top side

2.3 Mechanical dimensions

The dimensions of the MA3L120E07 adapter board are given in Figure 4.

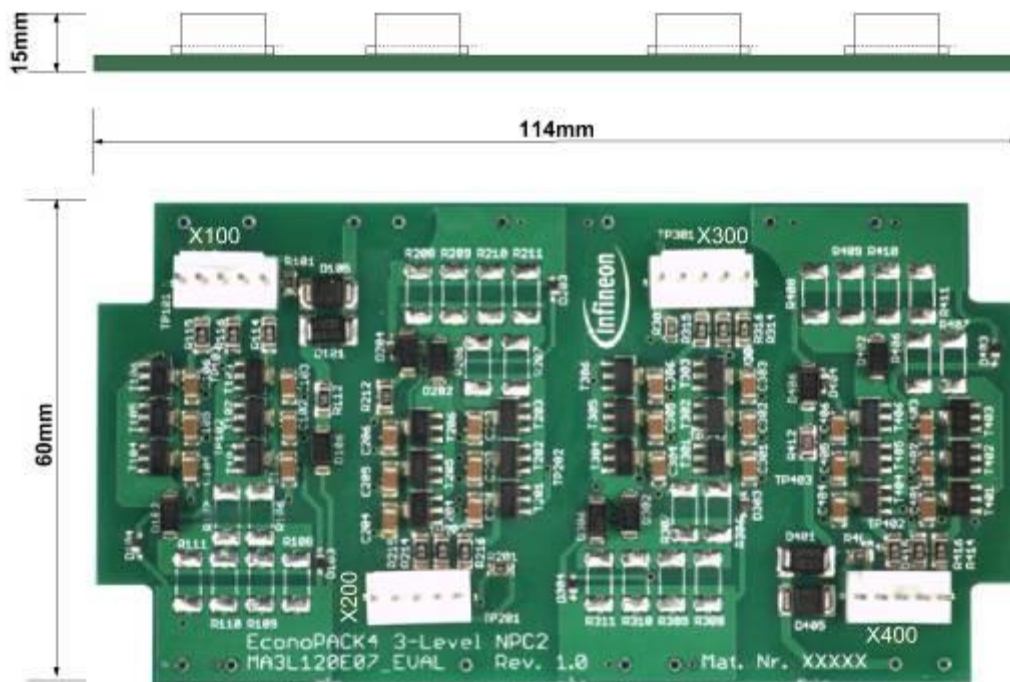

Figure 4: Mechanical dimensions of the MA3L120E07_EVAL

3 Pin assignments

All PWM, logic signals and voltage supplies have to be applied as listed in the following tables.

Table 2: Pin assignment of the connector X100 of the high side IGBT

Pin name	Pin function
X100-1	+15V_T1
X100-2	GND_T1
X100-3	-8V_T1
X100-4	PWM_T1
X100-5	DESAT1

Table 3: Pin assignment of the connector X200 of the inner high side IGBT

Pin name	Pin function
X200-1	+15V_T2
X200-2	GND_T2
X200-3	-8V_T2
X200-4	PWM_T2
X200-5	DESAT2

Table 4: Pin assignment of the connector X300 of the inner low side IGBT

Pin name	Pin function
X300-1	+15V_T3
X300-2	GND_T3
X300-3	-8V_T3
X300-4	PWM_T3
X300-5	DESAT3

Table 5: Pin assignment of the connector X400 of the low side IGBT

Pin name	Pin function
X400-1	+15V_T4
X400-2	GND_T4
X400-3	-8V_T4
X400-4	PWM_T4
X400-5	DESAT4

4 Functionality of the board

The MA3L120E07_EVAL adapter board is a complementary part of the evaluation kit to drive one 3-level IGBT module as shown in Figure 5. The adapter board should be pressed onto the EconoPACK™ 4 as described in the AN2010-06.



F3L2020E07-F-P_EVAL

MA3L120E07_EVAL

F3L400R07PT4

Figure 5: Mounting sequence of the Evaluation Kit

The IGBT module is not a part of this evaluation kit. The IGBT module needed can be purchased separately.

4.1 Power supply

The evaluation kit as shown in Figure 5 needs four external isolated power supplies of -8V/+15V. The magnitude of each power supply should not exceed the maximum supply voltage allowed for 1ED020112-F driver IC on the F3L2020E07-F-P_EVAL board, fixed at 28V. The power supply of the evaluation kit with four isolated -8V/+15 V voltage sources can be done using a MA040E12_EVAL⁴ evaluation board.

If the MA3L120E07 adapter board is not used in conjunction with the F3L2020E07-F-P_EVAL driver board, it can be supplied with isolated power supplies providing up to maximum $\pm 20V$.

The input PWM voltage level should be selected according to the power supply voltage level. If an asymmetrical supply voltage of -8V/+15V is applied, the PWM signal should not exceed +15V and should not be lower than -8V.

The voltage sources are applied to the corresponding driver channels using the connectors X100, X200, X300 and X400.

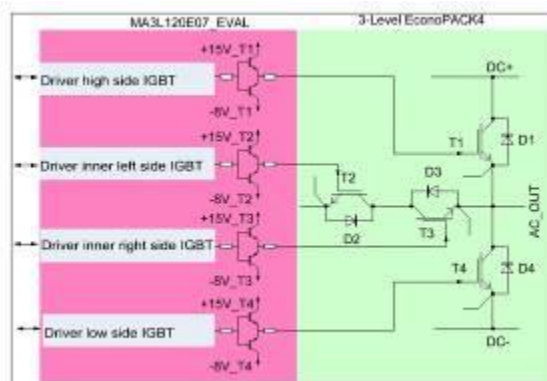

Figure 6: Principle diagram of the MA3L120E07_EVAL and 3-level EconoPACK™ 4

⁴ AN2010-04 MA040E12_EVAL Isolated Gate Driver Power Supply and Logic Interface for MIPAQ™ Serve

Figure 7 gives hints about the power as a function of the switching frequency. This power is needed to drive one IGBT of an F3L400R07PT4 EconoPACK™ 4 3-level module equipped with the adapter board at $T_{case} = 125^{\circ}\text{C}$ and $T_{amb} = 25^{\circ}\text{C}$. The adapter board is supplied with $-8\text{V}/+15\text{V}$.

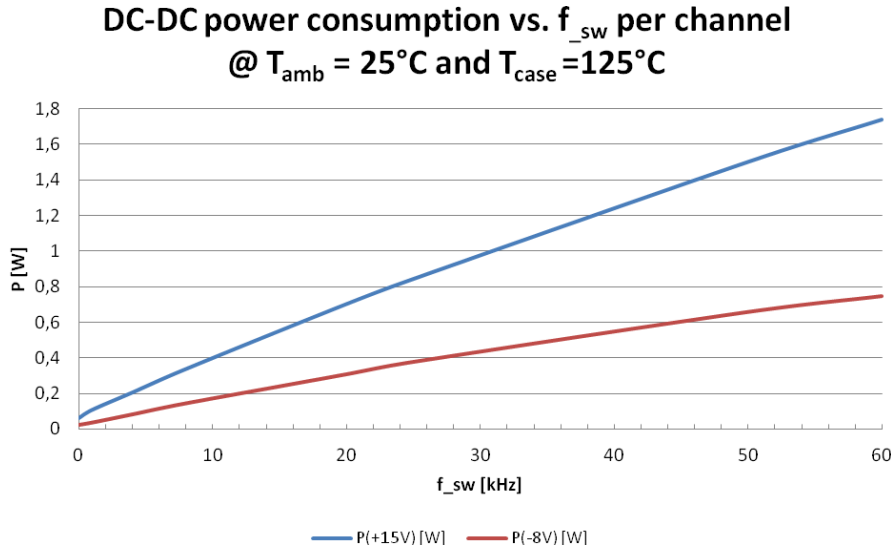

Figure 7: Power consumption of one IGBT of the 3-level leg

4.2 Booster

Figure 8 shows the booster circuit where three complementary pairs of transistors are used to amplify the input PWM signal. This allows to drive IGBTs that need more current than the driver IC can deliver. Three NPN transistors are used for turning-on the IGBT and three PNP transistors for turning-off the IGBT.

The transistors are dimensioned to provide enough peak current to drive all EconoPACK™ 4 3-level IGBT modules.

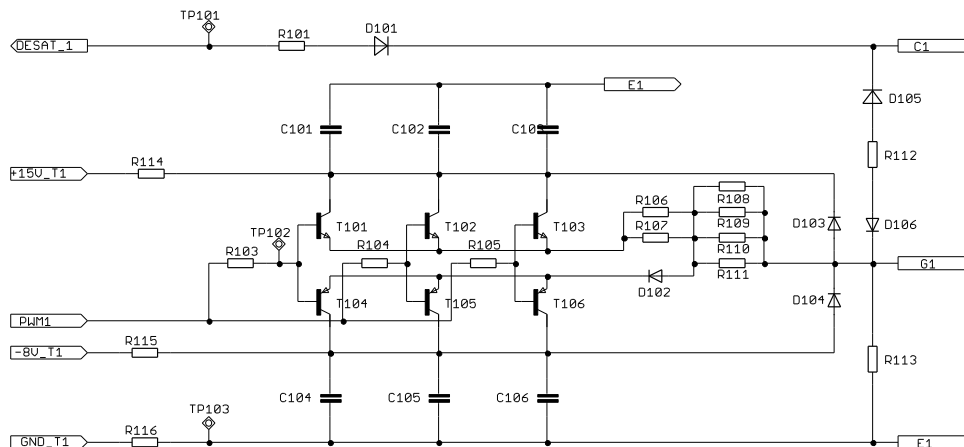

Figure 8: Schematic details of the output stage for a single IGBT driver

Gate resistors are connected between the booster stage and the IGBT module's gate terminals. These resistors should have a suitable rating for repetitive pulse power to avoid degradation.

4.3 VCE monitoring for short circuit detection

The short circuit protection of the four IGBTs is based on the monitoring of the collector emitter voltage for the corresponding IGBT, using the active clamping feature as represented in Figure 9. If the IGBT conducts a current several times higher than the nominal value, the transistor desaturates and the voltage across the device increases. This behavior can be used for short circuit detection and to turn-off of the IGBT. The rated short circuit withstand time for Infineon IGBT modules is 10µs. During this time, the short circuit needs to be detected and the IGBT has to be turned off without exceeding its maximum blocking voltage.

When the MA3L120E07_EVAL is connected to a F3L2020E07-F-P_EVAL driver board, each 1ED020112-F Coreless Transformer driver IC of the four IGBTs detects and handles the short circuit separately.

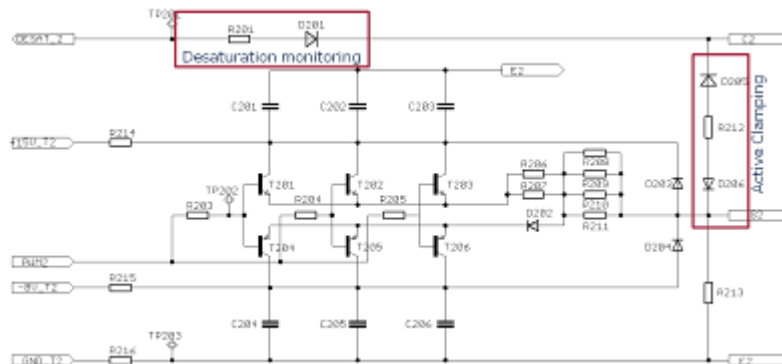

Figure 9: Desaturation protection and active clamping diodes

4.4 Active clamping function

Active clamping is a technique which keeps transient overvoltage below the critical limits when the IGBT turns off. The standard approach for active clamping is to use a TVS diode connected between the auxiliary collector and the gate of an IGBT module. When the Collector-Emitter voltage exceeds the diode breakdown voltage the diode current sums up with the current from the driver output. Due to the increased Gate-Emitter voltage, the transistor is held in an active mode and the turn-off process is prolonged. The dI_C/dt slows down which results in a limited voltage overshoot. Avalanche diodes conduct high peak currents during the time in which the clamping is actively limiting the overvoltage.

A typical turn-off waveform of a F3L400R12PT4_B26 module at room temperature without overvoltage limiting function can be seen in Figure 10a. Figure 10b shows the waveform with the same load conditions as Figure 10a but with active clamping function.

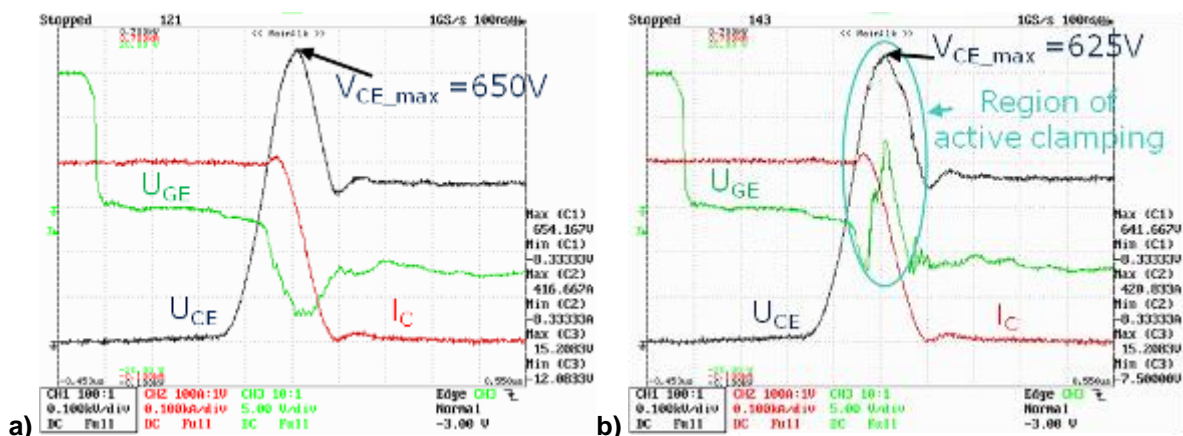

Figure 10: turn-off a) without active clamping

b) with active clamping function

4.5 Maximum switching frequency

The switching frequency on the adapter board is limited either by the maximum output power of the driver power supply or by the maximum temperature of the PCB due to the power losses in the external gate resistors. These power losses in the gate resistors depend on the IGBT gate charge, gate voltage magnitude

and on the switching frequency of the IGBT. Due to the power losses in the external gate resistors, heat will be generated, which leads to an increase of the PCB temperature in the neighborhood of these resistors. This temperature must not be higher than the maximum working temperature of the PCB, i.e. 105°C for a standard FR4 material.

The calculation of the power losses in the gate resistors can be done by utilizing equation (1):

$$P_{dis} = P(R_{EXT}) + P(R_{INT}) = \Delta V_{out} \cdot f_s \cdot Q_G \quad (1)$$

where:

- P_{dis} = dissipated power
- $P(R_{EXT})$ = dissipated power external gate resistors
- $P(R_{INT})$ = dissipated power internal gate resistor
- ΔV_{out} = voltage magnitude at the driver output
- f_s = switching frequency
- Q_G = IGBT gate charge for the given gate voltage range

The complete gate resistor consists of the internal gate resistor together with an external gate resistor and due to that, a part of the IGBT drive power losses will be dissipated directly to the PCB, whereas the other part of the losses will be dissipated to the ambient air. The ratio of the losses dissipated internally $P(R_{INT})$ and externally $P(R_{EXT})$ corresponds directly to the ratio of the mentioned R_{INT} and R_{EXT} resistors. According to -8/+15V operation, the datasheet value of Q_{GE} needs to be reduced by 20%.

Due to the PCB temperature criteria, the power dissipated in external gate resistors $P(R_{EXT})$ has to be considered for the thermal design.

Figure 11 illustrates the PCB board temperature around the gate resistors depending on the switching frequency and following conditions: $T_{case} = 125^\circ\text{C}$, $T_{amb} = 25^\circ\text{C}$, $V_{GE} = -8\text{V}/+15\text{V}$.

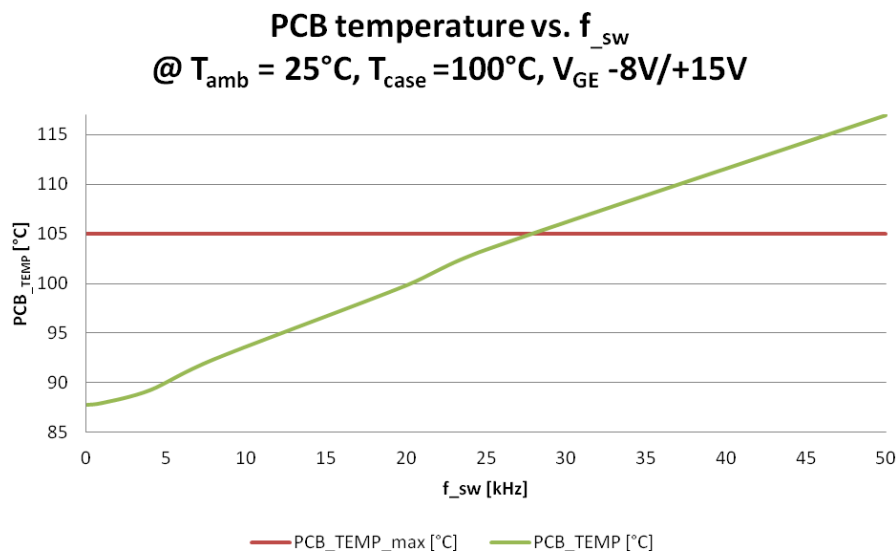

Figure 11: Local temperature development of the MA3L120E07_EVAL adapter board

5 Paralleling

In contrast to the operation of one single IGBT, where the operating point is relatively simple to set up, the switching of paralleled IGBT modules on the same operation point is not trivial. This can be explained by the fact that the IGBTs have a certain variation in their characteristics. A direct consequence of this is a slight current imbalance between the IGBTs. The biggest challenge is to minimize the deviation of the leg current to achieve highly efficient systems and an improved reliability.

Two main factors have a dominant role in the current maldistribution:

- the difference between the impedance of each leg of the paralleled setup
- the difference in the output voltages of the individual leg of the paralleled setup

5.1 Static current imbalance

The static current imbalance can be caused due to:

- the variation of the Collector-Emitter voltage of each leg of the paralleled setup
- the variation of the resistance of the main current path

5.2 Dynamic current imbalance

The dynamic current imbalance can be caused by

- the variation of the transmission characteristics caused by the different V_{GEth} of each IGBT
- the variation of the impedance of the main current path
- the stray inductance of the internal and external commutation path of the IGBT module
- the IGBT driver output resistance in the paralleled legs
- the transfer characteristic $I_C = f(V_{GE})$

5.3 Paralleling with MA3L120E07_EVAL

The MA3L120E07_EVAL was designed primarily to work with the evaluation driver board 3FL020E07-F-P1_EVAL, which allows the parallel connection of up to three modules, each equipped with one MA3L120E07_EVAL adapter board as represented in Figure 12a. In case of paralleling, the driver board does not need to be plugged into the complementary adapter board. The connection from the driver to the adapter boards is done utilizing the connectors on the top side of the driver board as shown in Figure 12b.

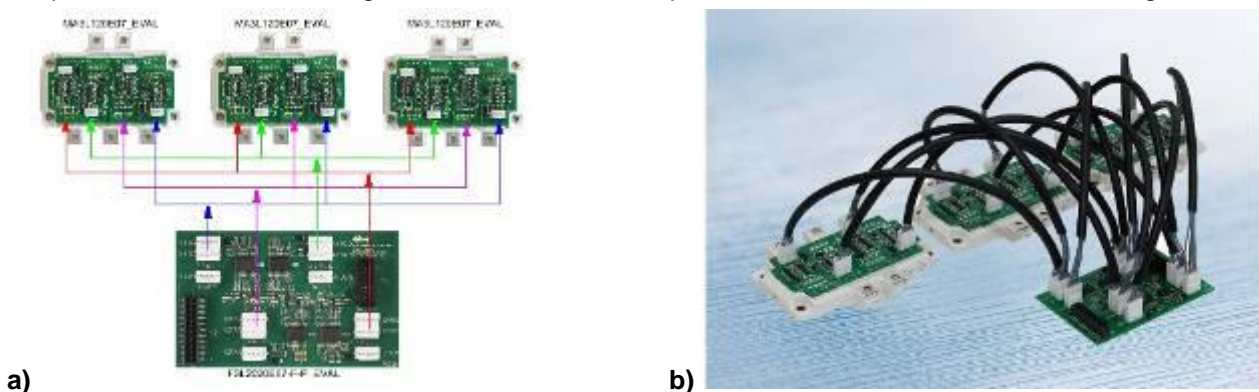

Figure 12: a) Principle of parallel connection, b) Photo of the setup

Figure 12b shows a parallel connection of three 3-level IGBT modules. The wires to connect the driver to the adapter boards should have the same length to avoid differences in signal run time between the gates of the three legs. Star connection of the IGBTs improves the reduction of cross flow in the auxiliary emitter paths during the switching sequence. The MA3L120E07_EVAL boards are equipped with 4R7 resistors in the auxiliary emitter path and other power supply lines (-8V / +15V) to reduce the current cross flow between the units of the paralleled circuits.

The MA3L120E07 adapter board is equipped with 4R7 decoupling resistors in the power supply lines by default. This avoids currents in the emitter path between the paralleled modules.

Figure 13a gives a hint about the balancing current flowing in the emitter paths when MA3L120E07_EVAL is equipped with 0R instead of 4R7. Balancing currents of up to 4A can be measured after the turn-on of the IGBT. With a standard equipped adapter board, the balancing current is reduced to a few mA as depicted in Figure 13b.

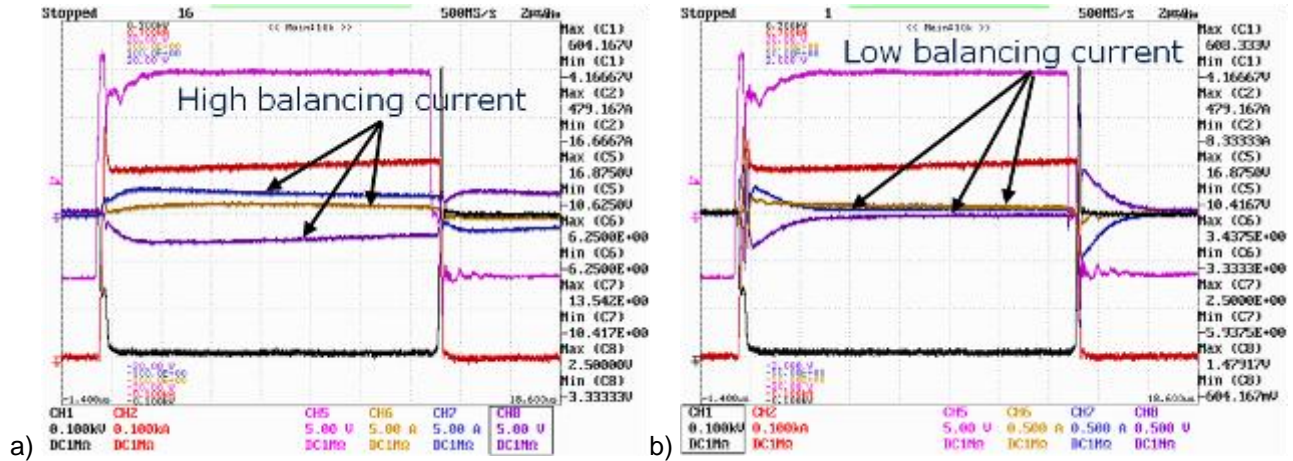

Figure 13: Current distribution in the auxiliary emitter paths

a) With 0R as decoupling resistor

b) With 4R7 as decoupling resistor

Figure 14 shows the turn-on and turn-off behavior of 3 IGBT modules in parallel and their current sharing on the AC terminals.

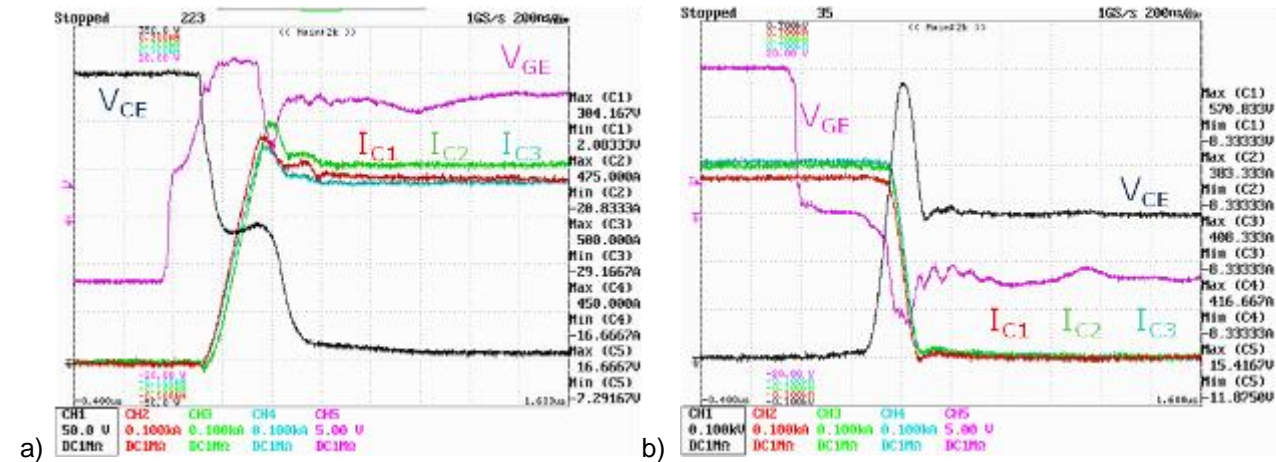

Figure 14: Current distribution on the AC terminals of 3 parallel F3L400R07PT4 modules

a) Turn-on

b) Turn-off

The E_{on} and E_{off} values measured with a gate resistance $R_{gon} = R_{goff} = 1R5$ and at ambient temperature of 25°C are listed in Table 6.

Datasheet values of E_{on} and E_{off} for F3L400R07PT4: $E_{on} = 8.75$ mJ; $E_{off} = 18$ mJ

Table 6: Overview of E_{on} and E_{off} of three paralleled F3L400R07PT4 modules

Device under Test	DUT1	DUT2	DUT3
E_{on} [mJ]	12.27	12.15	12.2
E_{off} [mJ]	19.2	23	20

Compared to the datasheet values, the measured E_{off} values are similar. The variation in E_{on} is higher and in general higher than the datasheet values. Nevertheless the influence of E_{off} is dominating.

6 Schematics and Layouts

To meet the individual customer requirements and to make the evaluation adapter board simple for development or modification, all necessary technical data like schematic, layout and components are included in this chapter.

6.1 Schematics

Figure 15 to Figure 18 depict the driving circuit of the IGBTs.

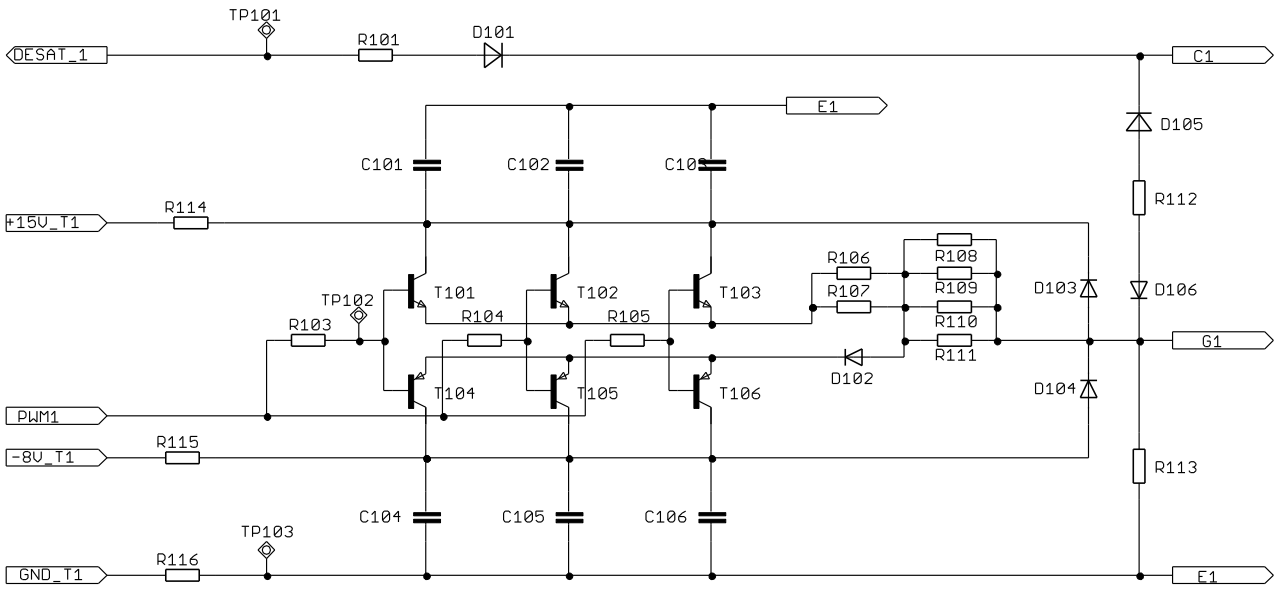

Figure 15: Driving circuit of the high side IGBT

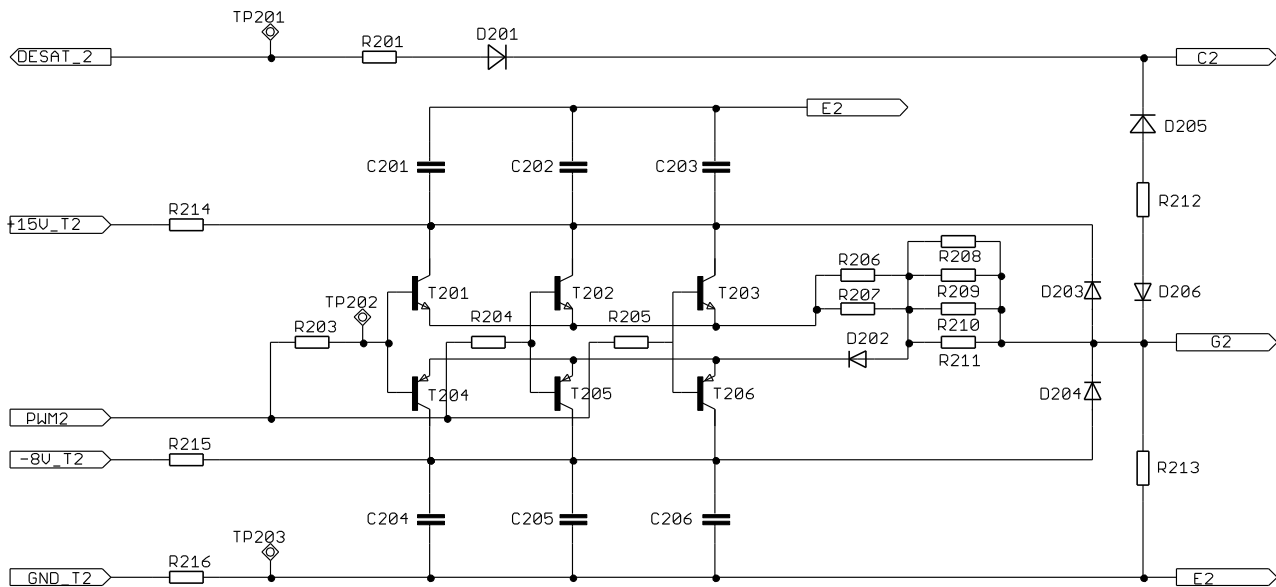

Figure 16: Driving circuit of the inner left side IGBT

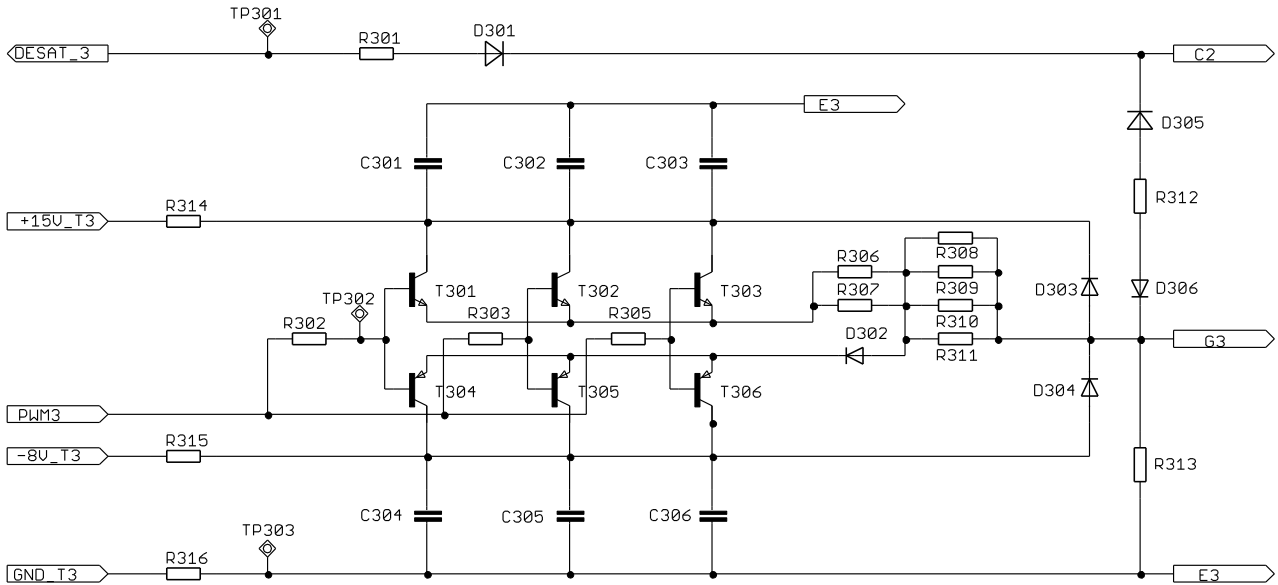

Figure 17: Driving circuit of the inner right side IGBT

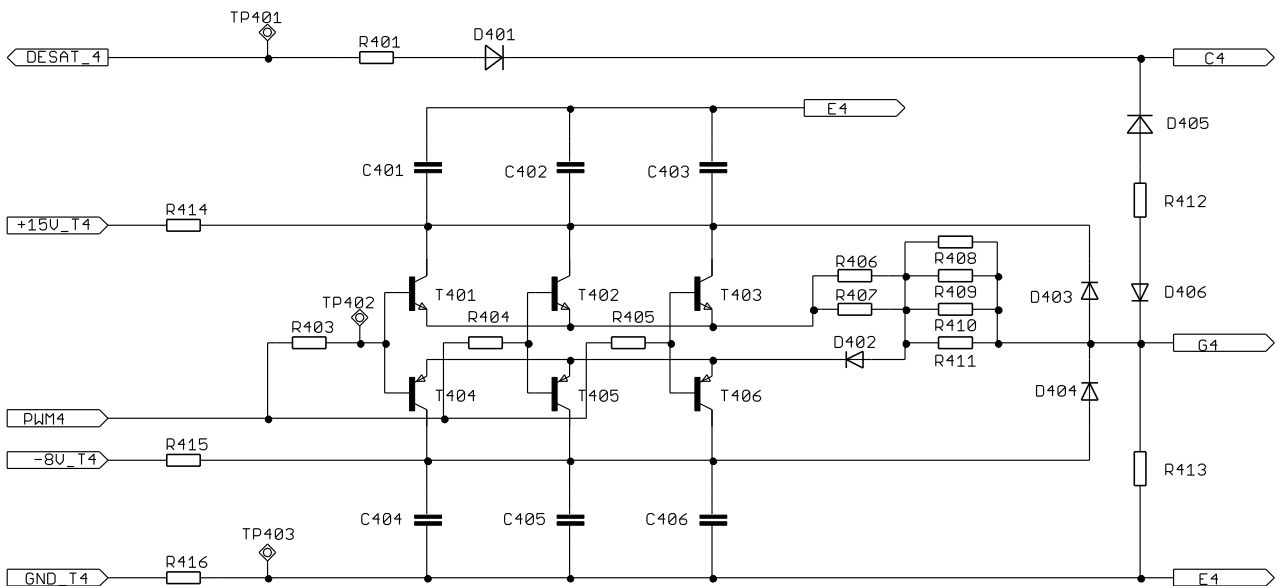

Figure 18: Driving circuit of the low side IGBT

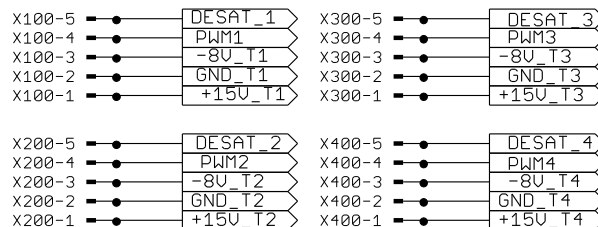

Figure 19: Pin description of the connectors of the MA3L120E07_EVAL

6.2 Layouts

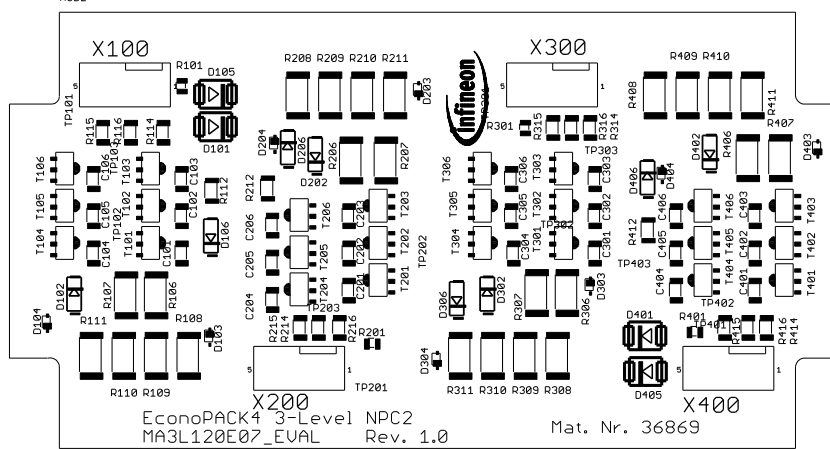

Figure 20: Component placement, top side

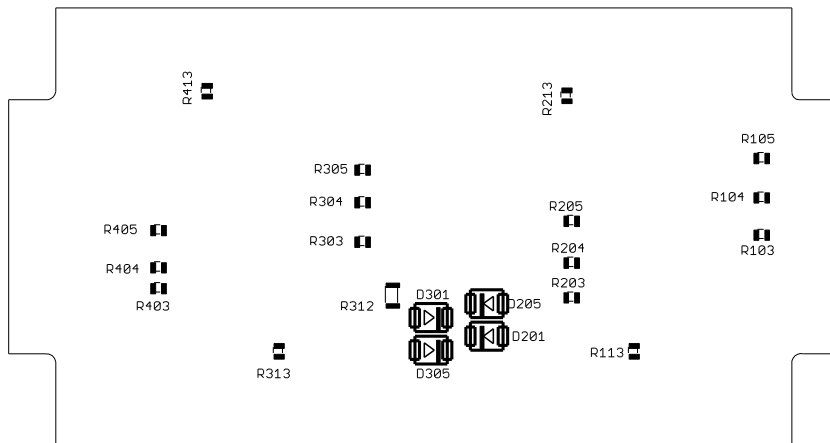

Figure 21: Component placement, bottom side

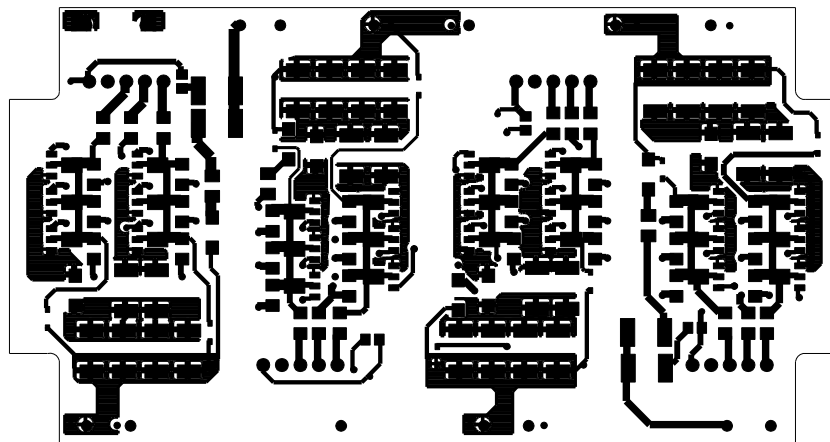

Figure 22: Top-Layer

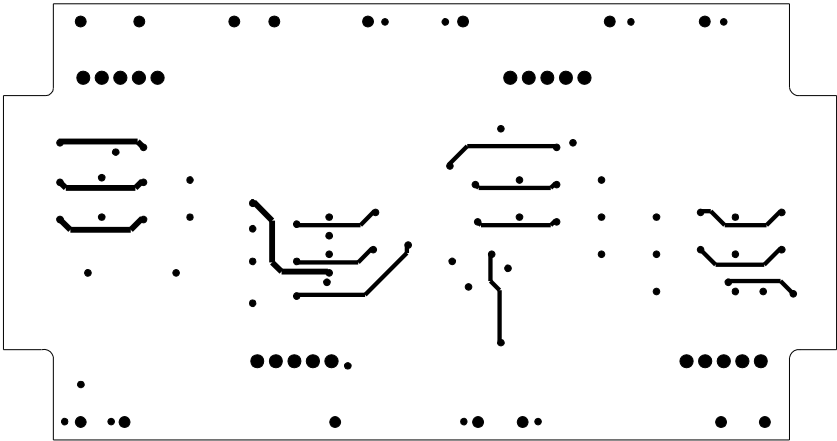

Figure 23: Layer 2

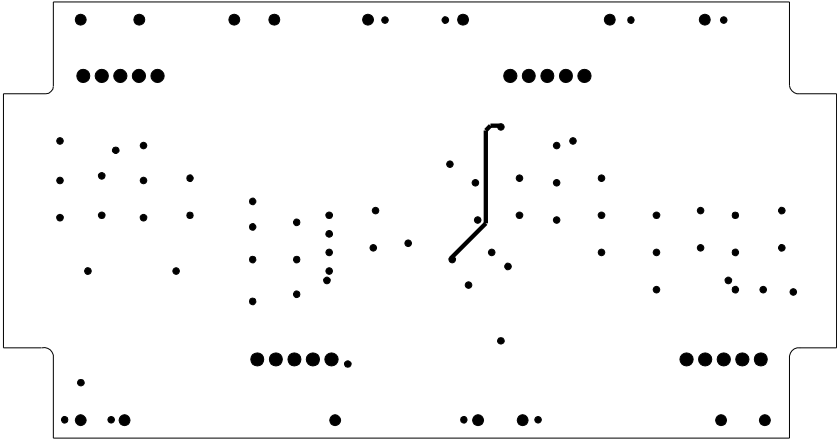

Figure 24: Layer 3

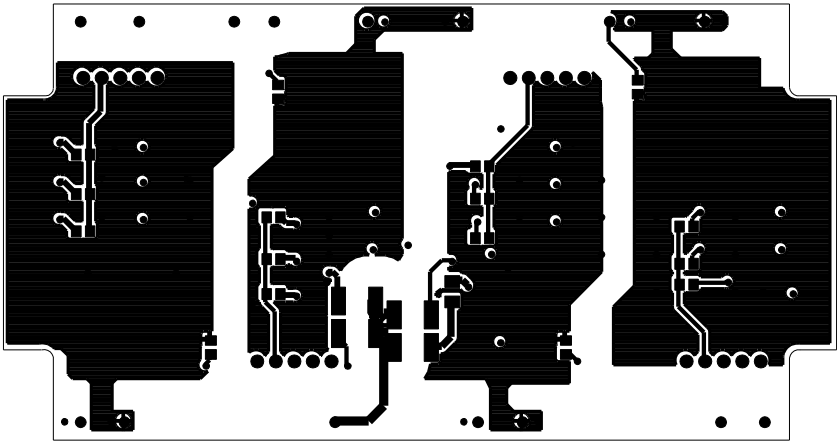

Figure 25: Bottom-Layer

7 Bill of Material of MA3L120E07_EVAL

The bill of material includes a part list as well as assembly notes.

The tolerances for resistors should be less or equal to $\pm 1\%$, for capacitors of the type COG less or equal to $\pm 5\%$ and for capacitors of the type X7R less or equal to $\pm 10\%$.

Type	Value	Package	QTY	Name Part	Manufacturer
Resistor	1R8	R-EU_1206	4	R112, R212, R312, R412	-
Resistor	Puls resistors optional	R-EU_1206	24	R106, R107, R108, R109, R110, R111, R206, R207, R208, R209, R210, R211, R306, R307, R308, R309, R310, R311, R406, R407, R408, R409, R410, R411	-
Resistor	4R7	R-EU_1206	12	R114, R115, R116, R214, R215, R216, R314, R315, R316, R414, R415, R416	-
Resistor	1k	R-EU_0805	4	R101, R201, R301, R401	-
Resistor	39R	R-EU_0805	12	R103, R104, R105, R203, R204, R205, R303, R304, R305, R403, R404, R405	-
Resistor	10k	R-EU_0805	4	R113, R213, R313, R413	-
Capacitor	4 μ 7/25V/X7R	C1206	24	C101, C102, C103, C104, C105, C106, C201, C202, C203, C204, C205, C206, C301, C302, C303, C304, C305, C306, C401, C402, C403, C404, C405, C406	Murata
Diode	ES1D	DO214AC	8	D102, D106, D202, D206, D302, D306, D402, D406	-
Diode	P6SMB480C	SMB	2	D105, D205, D305, D405	-
Diode	STTH112U	SOD6	4	D101, D201, D301, D401	-
Diode	BAT165	SOD323R	8	D103, D104, D203, D204, D303, D304, D403, D404	Infineon
Bipolar transistor	ZXTN2010Z	SOT89	12	T101, T102, T103, T201, T202, T203, T301, T302, T303, T401, T402, T403	Diodes
Bipolar transistor	ZXTP2012Z	SOT89	12	T104, T105, T106, T204, T205, T206, T304, T305, T306, T404, T405, T406	Diodes
Connector	MOLEX 2223-2051	PITCH KK	4	X100, X200, X300, X400	Molex

8 How to order the Evaluation Adapter Board

Every Evaluation Adapter Board has its own IFX order number and can be ordered via your Infineon Sales Partner.

Information can also be found at the Infineon's Web Page: www.infineon.com

CAD-data for the board described here are available on request. The use of this data is subjected to the disclaimer given in this AN. Please contact: WAR-IGBT-Application@infineon.com

IFX order number for MA3L120E07_EVAL: SP000979670

IFX order number for F3L2020E07-F-P_EVAL: SP001000644

9 Literature

- [1] AN2012-03 Evaluation Driver Board for EconoPACK™ 4 3-level Modules in NPC2-Topology with 1ED020I12-F gate driver IC
- [2] Zhang Xi, Uwe Jansen, Holger Rüthing: 'IGBT power modules utilizing new 650V IGBT3 and Emitter Controlled Diode3 chips for 3-level converter' ISBN: 978-3-8007-3158-9 Proceedings PCIM Europe 2009 Conference