

Upgrade Your TAXI-275 with HOTLink®

Associated Project: No
Associated Part Family: CY7B923 / CY7B933
Software Version: NA
Related Application Notes: AN1162

AN1038 will explain how to upgrade TAXI-275 devices with the HOTLink® devices. It will aid in the migration of TAXI-275 designs to the HOTLink architecture.

Contents

HOTLink® Introduction..... 1
 Upgrade from TAXI-275 2
 A Brief Explanation of TAXI-275 3
 Simplifying Your System with HOTLink 3
 Summary 13
 References 13
 Worldwide Sales and Design Support 15

HOTLink® Introduction

The HOTLink family of devices transfers data from point to point over high-speed serial links at 160 to 330 Mbits/second (Figure 1). The CY7B923 Transmitter (Figure 2) takes an 8-bit parallel data stream and encodes it using the Fibre Channel and ESCON compliant 8B/10B code. This code maps all 8-bit data characters into a 10-bit transmission code that ensures that the transmission signal contains suitable transitions for recovery by the receiving device. The transmitter then takes this 10-bit data word and converts it to a serial bit stream and sends it at 10 times the byte rate over a serial transmission link.

Figure 1. HOTLink System Diagram

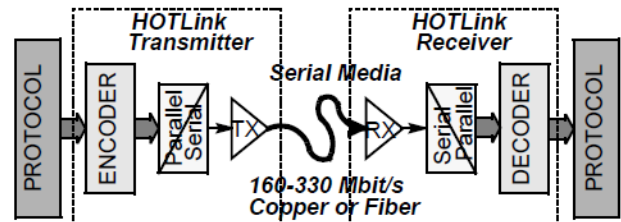
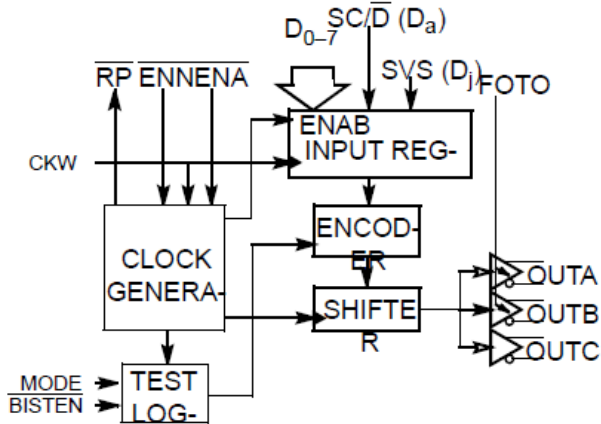
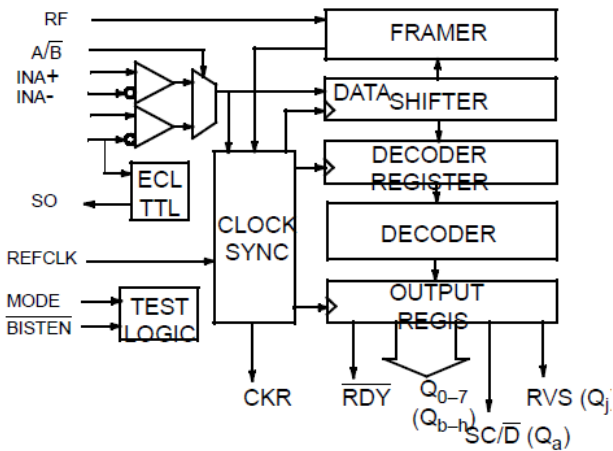

Figure 2. CY7B923 Transmitter Logic Diagram



The CY7B933 HOTLink Receiver (Figure 3) connects to the other end of a transmission link that may consist of anything from a few inches of printed circuit board (PCB) trace to several kilometers of fiber-optic cable. The receiver decodes the incoming bit stream and reconstructs the original parallel data character, which is presented at the outputs and aligned with the recovered clock. The receiver, in addition to these tasks, checks the incoming data stream for errors that may have occurred in the serial transmission.

Figure 3. CY7B933 Receiver Logic Diagram



The SC/D (Special Character/Data) pin permits the transmission of command codes in addition to data characters. The codes are mapped to 10-bit transmission characters defined in the 8B/10B codes of the Fibre Channel standard. Commands can be sent as part of the transmission stream, to signal events such as Idle, Start-of-frame (SOF), End-of-frame (EOF), and so on.

Other features provide a complete solution for high-speed point-to-point communication in applications including interconnecting workstations, servers, mass storage, and video transmission equipment. These features include built-in self-test (BIST) for in-system diagnostic testing, unencoded mode for sending 10-bit data in systems that use a different encoding method, and a seamless parallel interface for connection to both asynchronous and clocked FIFOs. A brief description of the various features of HOTLink is given below with a more detailed discussion found in the CY7B923/CY7B933 HOTLink Transmitter/Receiver datasheet. The PLCC pinouts for these devices are shown in Figure 4.

Upgrade from TAXI-275

The following sections explain the architectural advantages of the Cypress CY7B923/CY7B933 HOTLink Transmitter and Receiver over the devices from AMD. This section begins with a brief explanation of the Am79168/Am79169 TAXI-275 devices. It then follows with a list of HOTLink features that make designing these high-speed point-to-point systems easier.

Figure 4. CY7B923 and CY7B933 Pin Configurations

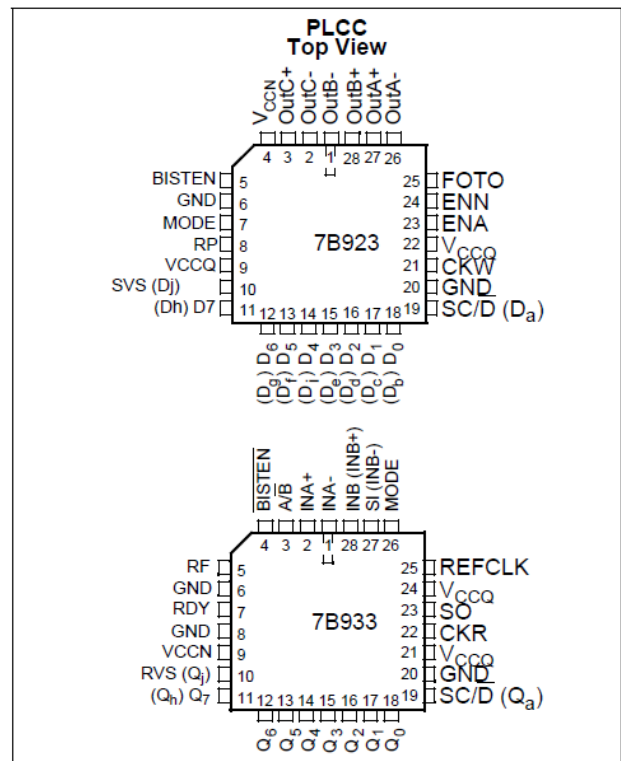
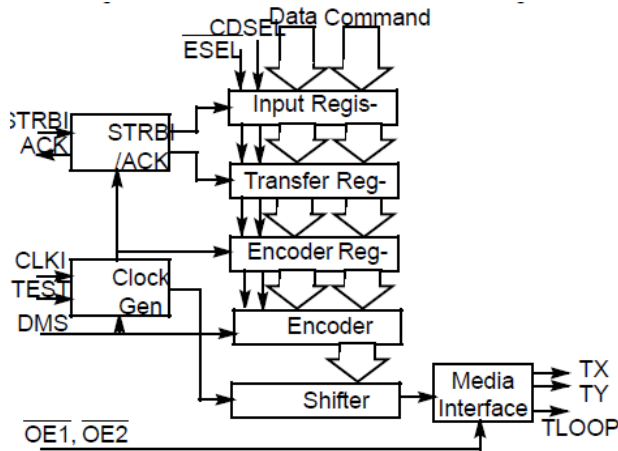

Figure 5. TAXI-275 Transmitter Block Diagram



A Brief Explanation of TAXI-275

The Am79168/Am79169 TAXI-275 devices are similar to HOTLink. The Am79168 TAXI-275 Transmitter, shown in Figure 5, converts 8-bit or 10-bit parallel data into 10- or 12-bit transmission codes using either the 8B/10B code or the 10B/12B code. This data is encoded and shifted out serially over a transmission link operating at speeds of 175 to 275 Mbaud. The Am79169 TAXI-275 Receiver, shown in Figure 6, converts the incoming serial data into parallel words, and decodes and presents the original words in 8-bit or 10-bit format to the outputs along with the recovered clock. The pinouts of the Am79168 Transmitter and the Am79169 Receiver are shown in Figure 7.

Figure 6. TAXI-275 Receiver Block Diagram

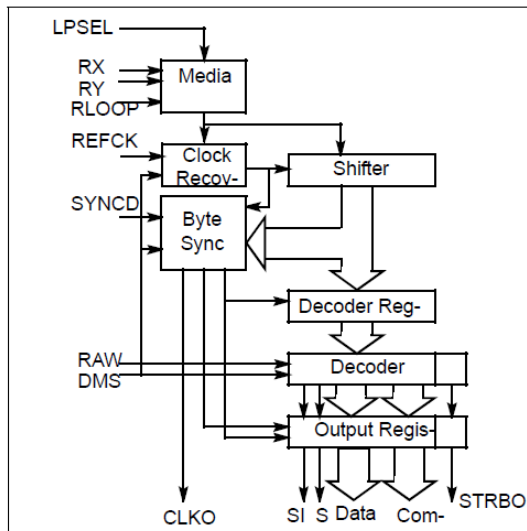
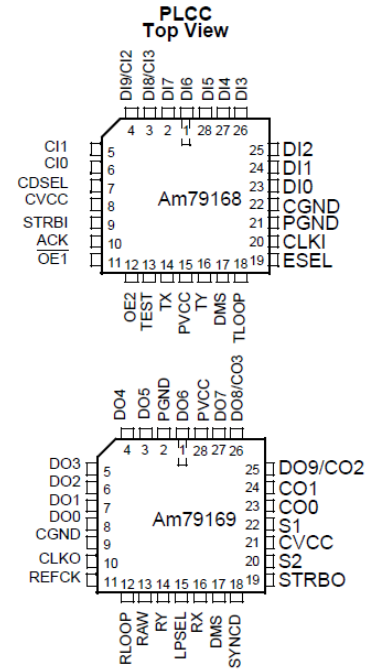

Figure 7. Am79168 and Am79169 Configurations



Simplifying Your System with HOTLink

HOTLink offers additional features that will simplify system design. Below is a list of these features along with their benefits when designing high-speed point-to-point serial communications systems with Cypress HOTLink devices.

Multiplexed Command and Data

The TAXI-275 has separate inputs for command and data, while the HOTLink devices have an integrated command and data path. The status of SC/D pin (Special Character/Data) determines if HOTLink sends a Special Character (Command) or data.

The integrated command and data paths of HOTLink allow simplification of the controller architecture. Instead of creating a separate command path, command codes can be integrated within the data stream with the addition of a ninth bit (the SC/D) bit that indicates the status of the associated 8 bits of information.

More Outputs

The HOTLink transmitter has three identical differential positive ECL (PECL) serial output ports. Two of these outputs can be turned off under control of fiberoptic transmitter off (FOTO) pin. The TAXI-275 devices have only one differential PECL output pair and an additional single-ended TLOOP output intended for use in loop-back testing.

More Inputs

The HOTLink Receiver has two differential interfaces to the serial transmission medium (INA± and INB±) whereas the TAXI-275 devices have only a single input pair (RX,RY) and a single ended PECL input, RLOOP, used for loop-back testing. The media inputs of the HOTLink Receiver can be used to provide loop-back testing, redundant transmission paths, or more complex networks configurations.

Loop-back testing ensures that a node is sending and receiving data properly. In a typical network-style configuration, both the transmitter and receiver will exist for each node. In loop-back testing a redundant output from the transmitter is fed back to the additional input on the receiver. The TAXI-275 devices have an extra single-ended 100K PECL output, TLOOP, and an extra single-ended 100K PECL input, RLOOP, that are used for loop-back testing. The HOTLink devices offer a more robust loop-back capability by offering redundant differential output pairs that can be connected to an additional differential input structure on the receiver, as shown in [Figure 8](#). The additional single-ended input/output pair of the TAXI-275 does not provide a robust loop-back testing configuration.

In addition, the redundant outputs of the transmitter can be used in conjunction with the additional inputs of the receiver to build more complex network structures by allowing a single transmitter to communicate with multiple receivers, or a single receiver to be connected with multiple transmitters. The multiple outputs can also be used to build redundant paths between two nodes.

More Flexible Command Codes

A coding system is necessary in serial communication systems to ensure that the receiving device can determine the boundary between adjacent bits. The code makes sure that enough signal transitions exist on the transmission channel to track bit boundaries. In other words, the code must ensure that the clock used by the transmitter to transmit the data is embedded within the data stream. The code maps each character into a code word that ensures that a minimum transition density and run length is maintained.

Both HOTLink and TAXI-275 use the transmission code specified by ANSI X3T9.3 Fibre Channel and IBM ESCON standards. This code converts 8 bits into 10 transmission bits (8B/10B). This code generates Non Return to Zero (NRZ) transmission data where a logical 1 is represented by a HIGH level and a logical 0 is represented by a LOW level. The complete code tables are listed at the end of the CY7B923/CY7B933 HOTLink Transmitter/Receiver data sheet. This code ensures not only minimum transition density and run length, but also that the average number of 1s and 0s are equal. This feature of the code prevents the average DC level on the transmission link from “wandering” based on the data that is being sent.

In addition to specifying a mapping of every character into a transmission symbol, the code also specifies several command codes. These codes are useful for low level signaling without involving higher level protocols. They can be used to indicate information such as HALT, End-of-Frame, or Start-of-Frame.

[Table 1](#) shows the valid special characters and sequences that HOTLink can both encode on the transmitting end and decode on the receiving end. The first column in the table indicates the byte name of the special character. In the Fibre Channel and ESCON notation Special Characters are denoted with a ‘K’ prefix and Data Characters are denoted with a ‘D’ prefix. The first twelve Special Characters are defined in the Fibre Channel and ESCON specifications. The second column of the table gives the code name, both in decimal and hexadecimal notation, of the binary pattern on the I/O pins. The third column, bits, shows the pattern presented to the transmitter’s data lines. This pattern, in combination with SC/D HIGH, will cause either the pattern in column four or column five to be sent. The pattern that the transmitter sends depends on the current Running Disparity.

In order to ensure that the average number of 1s and 0s that are sent across the communications channel is equal, both the transmitter and receiver keep track of the Running disparity of the data that was previously sent. running disparity (RD) can either be positive (+) or negative (-). In general, RD will be positive if, in the last transmission word, there were more 1s sent than 0s and it will be negative if there were more 0s sent than 1s. If RD is negative, the transmitter will send the code in column four and if RD is positive then the transmitter will send the code in column five.

Both HOTLink and TAXI-275 can send all codes labeled C0.0 through C11.0 in [Table 1](#). Because of the different architectures of these two devices, the data presented to the inputs of the transmitter will be different, but the code sent across the transmission medium will be identical.

The next three codes represent sequences that the transmitter can send. For example, if the transmitter controller presents C0.1 (binary pattern 001 00000) to the data lines, then the transmitter will send -K28.5+, D21.4, D21.5, D21.5. In other words, the transmitter will send a negative K28.5 Special Character, a D21.4 (binary 100 10101) Data Character, and two D21.5 (binary 101 10101) Data Characters. It will continue to send this pattern as long as C0.1 is present at its inputs. The receiver will decode this pattern as a C1.7 or C5.0 depending on its current Running Disparity followed by D21.4 and two D21.5s. This pattern is defined in the Fibre Channel standard as the IDLE pattern. The ability of the transmitter to send this pattern as well as the R_RDY (Receiver Ready) pattern greatly simplifies controller design. The TAXI-275 devices have no ability to send complex data patterns with a single code as shown by the word **NONE** in [Table 1](#) under the TAXI-275 Code column.

Figure 8. Example HOTLink Loop-Back System Connection

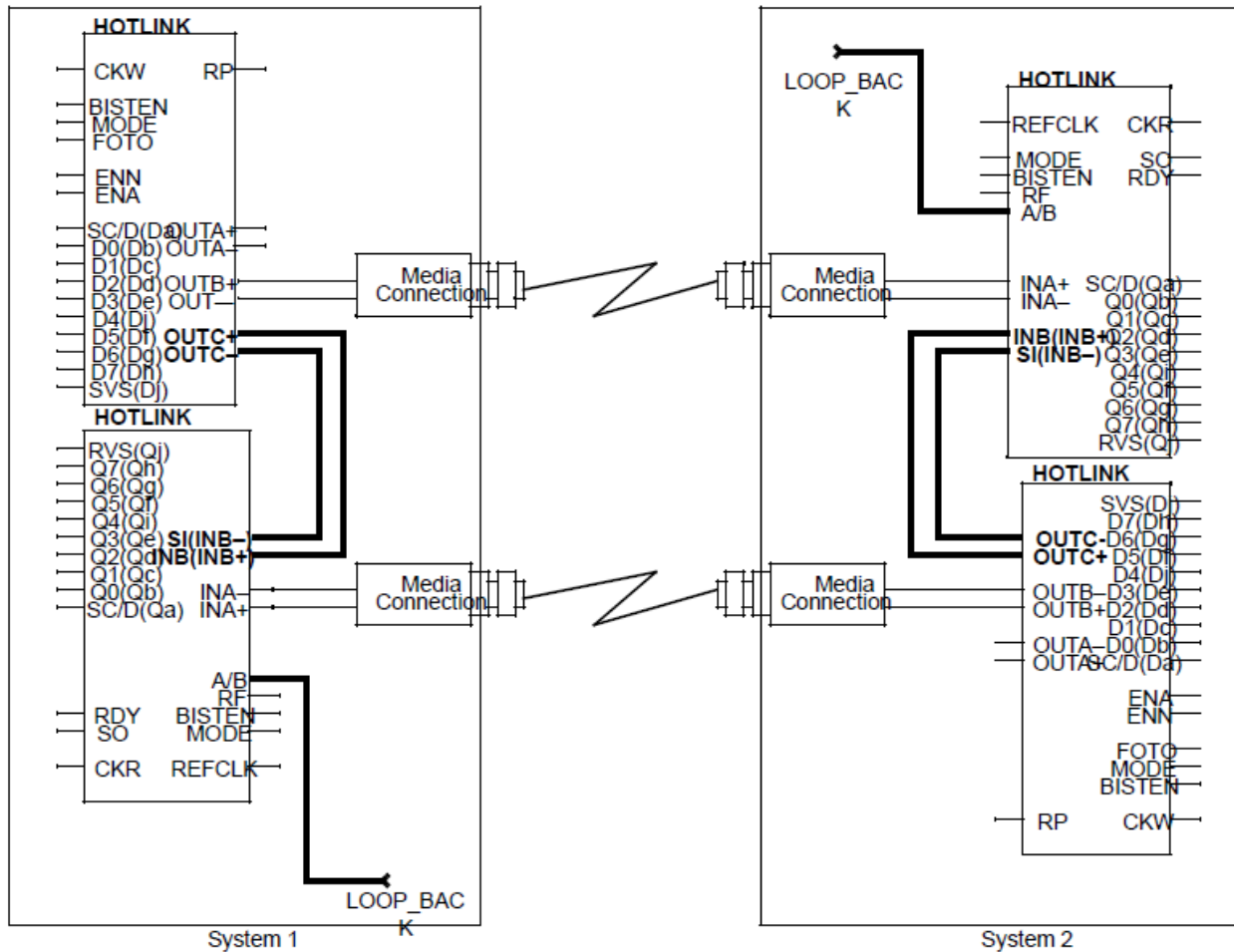

In addition, if C2.1 is presented to the transmitter, it will send either a negative K28.5 or a positive K28.5, depending on the RD. It will then modify the least significant bit (LSB) of the subsequent data word to be either a 0 if RD was (-) or a 1 if RD was (+). This simplifies controllers when building EOF delimiters where the second byte is determined by the current RD. These packet structures are necessary to conform to the Fibre Channel specification. The TAXI-275 device only has the capability of modifying the LSB of two different Data Characters, limiting the possible EOF delimiters that can be constructed.

C7.1 sends the ESCON Connect-SOF delimiter and C7.2 sends the Passive-SOF delimiter. C0.7 sends a deliberate code rule violation and has the same effect as having the send violation symbol (SVS) pin HIGH during a character transmission. C1.7 sends a negative K28.5 regardless of the current running disparity. The receiver will decode this as either a C5.0 if its current RD was negative or as a C1.7 if its current RD was positive. C2.7 sends +K28.5 with the receiver decoding this as either a C5.0 or a C2.7 if its current RD was negative. Lastly, C4.7 sends a deliberate Running Disparity violation pattern. All of these codes simplify controller design as well as assist with in-system testing. TAXI-275 does not have the ability to send any of these codes.

Table 1. HOTLink Valid Special Character Codes and Sequences (SC/D = HIGH)

HOTLink Special Code Byte Name	Special Code Name		Bits		Current RD-		Current RD+		Receiver Output Code Name	TAXI Code
			HGF	EDCBA	abcdei	fghj	abcdei	fghj		
K28.0	C0.0	(C00)	000	00000	001111	0100	110000	1011	C0.0	K28.0
K28.1	C1.0	(C01)	000	00001	001111	1001	110000	0110	C1.0	K28.1
K28.2	C2.0	(C02)	000	00010	001111	0101	110000	1010	C2.0	K28.2
K28.3	C3.0	(C03)	000	00011	001111	0011	110000	1100	C3.0	K28.3
K28.4	C4.0	(C04)	000	00100	001111	0010	110000	1101	C4.0	K28.4
K28.5	C5.0	(C05)	000	00101	001111	1010	110000	0101	C5.0	K28.5
K28.6	C6.0	(C06)	000	00110	001111	0110	110000	1001	C6.0	K28.6
K28.7	C7.0	(C07)	000	00111	001111	1000	110000	0111	C7.0	K28.7
K23.7	C8.0	(C08)	000	01000	111010	1000	000101	0111	C8.0	K23.7
K27.7	C9.0	(C09)	000	01001	110110	1000	001001	0111	C9.0	K27.7
K29.7	C10.0	(C0A)	000	01010	101110	1000	010001	0111	C10.0	K29.7
K30.7	C11.0	(C0B)	000	01011	011110	1000	100001	0111	C11.0	K30.7
Sequences										
Idle	C0.1	(C20)	001	00000	-K28.5+,D21.4,D21.5,D21.5, repeat			C5.0, D21.4, D21.5, D21.5	NONE	
R_RDY	C1.1	(C21)	001	00001	-K28.5+,D21.4,D10.2,D10.2, repeat			C5.0, D21.4, D10.2, D10.2	NONE	
EOFxx	C2.1	(C22)	001	00010	-K28.5,Dn.xxx0	+K28.5,Dn.xxx1	C5.0, Dn.xxx0 or C5.0, Dn.xxx1		NONE	
Follows K28.1 for ESCON Connect-SOF (Rx indication only)										
C-SOF	C7.1	(C27)	001	00111	001111	1000	110000	0111	C7.1	NONE
Follows K28.5 for ESCON Passive-SOF (Rx indication only)										
P-SOF	C7.2	(C47)	010	00111	001111	1000	110000	0111	C7.2	NONE
Code Rule Violation and SVS Tx Pattern										
Exception	C0.7	(CE0)	111	00000	100111	1000	011000	0111	C0.7	NONE
-K28.5	C1.7	(CE1)	111	00001	001111	1010	001111	1010	C5.0 or C1.7	K28.5+
+K28.5	C2.7	(CE2)	111	00010	110000	0101	110000	0101	C5.0 or C2.7	NONE
Running Disparity Violation Pattern										
Exception	C4.7	(CE4)	111	00100	110111	0101	001000	1010	C4.7	NONE

Reframing

In a serial transmission system, the receiving device must have a method of determining byte boundaries. In many systems a unique special character is used for this purpose. When the byte framer is active, the receiver looks for (frames on) K28.5 SYNC characters present in the data stream. This character must be unique, such that any valid combination of other bits within the transmission stream will not erroneously create this synchronization (SYNC) symbol. Transmission line errors may cause some of the bits within the information stream to become changed in such a way that the bits produce an erroneous (alias) SYNC. If the receiver has single-byte framing, this will cause the receiver to become misaligned, with all subsequent data being decoded incorrectly.

Both the HOTLink and TAXI-275 devices have the capability for double byte framing. Both devices Reframe on two occurrences of the Special Character K28.5 separated by 0, 1, 2, or 3 words (0, 10, 20, or 30 bits) as shown in Figure 9.

Figure 9. Double-Byte Reframing

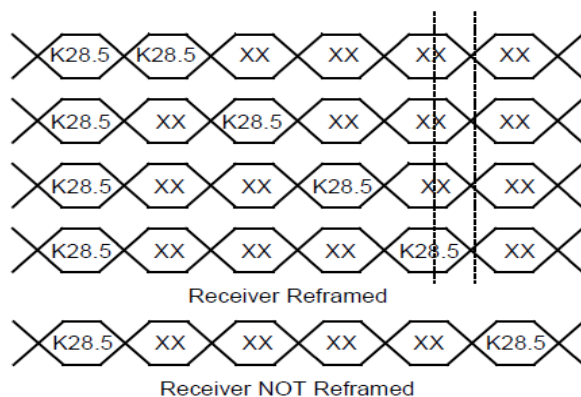

The HOTLink RF pin is used to activate and deactivate the reframing option. This is useful in systems that wish to prevent byte misalignment from alias SYNCs during data packets. Byte misalignment will cause all subsequent data in a packet to be corrupted instead of just the word or words that were corrupted due to transmission errors. Single-byte reframing is active for the first 2 K bytes after the RF pin is asserted HIGH. This feature allows the receiver to SYNC to the first K28.5. After 2 K bytes during RF HIGH, double-byte reframing will be activated. When activated, the single-byte frame saves 10 mA.

HOTLink pads the spaces between data packets with SYNC characters. When the “No Enable” (ENN and ENA = HIGH) condition exists, the transmitter fills the unused bandwidth with K28.5s. This pad string should be identified at the receiver so that the receiving system is not forced to process this information.

TAXI-275 has no method of ignoring multiple SYNC characters and preventing them from being passed to the receiving system. The TAXI-275 STRBO pin pulses LOW in the presence of new Command or Data at the output register. It pulses LOW, therefore, every time a K28.5 character is received. If multiple SYNCs are passed to the outputs of the receiver, the receive FIFO will overflow with SYNC characters, which will require external decoder logic to discard this extraneous information.

HOTLink eliminates this problem by only pulsing the RDY pin LOW during the last SYNC character in a string of SYNC characters (the first SYNC character of a new packet of information). This is important in systems that have bursty data transmission or transmit data slower than the maximum data operating frequency. This prevents redundant information from being passed to the receive system, yet maintains packet boundaries for easy packet identification.

Higher Operating Frequency

HOTLink has a much broader frequency range than the TAXI-275 devices. TAXI-275 operates from 175 to 275 Mbaud. This means that in 8B/10B mode, TAXI-275 can transmit and receive parallel data at rates from 17.5 to 27.5 MBytes/s. HOTLink, on the other hand, can transmit and receive parallel data at rates from 16 to 33 MBytes/s, allowing a much wider possible range of operating frequencies.

BIST

Built-In Self-Test (BIST) can be used to test the transmitter, receiver, and the link connecting them. During BIST (see Figure 10), the transmitter repeats a pattern representing all possible data and command characters, decodes them into transmission symbols and passes them to its outputs. The receiver, while in BIST, waits for the symbol that represents the beginning of the BIST pattern. It then decodes this and every following symbol and compares them with an internally generated pattern created by a pattern generator that matches the transmitter pattern generator. Detected errors at the receiver are indicated with pulses on the received violation symbol (RVS) while completed BIST loops are indicated with pulses on the receiver RDY line. The BIST function checks the entire function of the transmitter (except the transmitter input pins and the bypass function in the Encoder), the serial link, and the receiver.

These BIST functions are not implemented in the TAXI-275 devices. A substantial amount of additional circuitry is required in a system in order to integrate this function. This type of testing is necessary for many types of in-system diagnostic testing, including device functionality and link integrity.

Parallel Interface

The TAXI-275 devices have two methods of strobing data into the device, synchronous and asynchronous. In the asynchronous mode of operation, a strobe line is used in conjunction with an acknowledge line to present data to the device. In this mode of operation the maximum operating frequency for the TAXI-275 devices under the most ideal of conditions is no faster than 20 MHz.

In the synchronous mode of operation, which is the most common method of device operation, the TAXI-275 device requires that the STRBI (Input Strobe) and the CLKI (Input Clock) be tied together. To enable or disable data in this mode requires external logic with slower than optimal (<275 Mbaud) operation. HOTLink has a very simple interface that allows seamless connection to both asynchronous and clocked FIFOs. On the transmitter, two enable inputs control when data is to be transmitted. When the ENA input is asserted, data on the data lines is serialized and transmitted. When the ENN line is asserted, data that is presented on the data lines during the next rising edge of the CLK input is transmitted. This allows efficient, synchronous state machines to control the flow of data over the serial link. In addition, the read pulse (RP) output can be connected to the R (read) input of asynchronous FIFOs, as shown in [Figure 11](#), to provide a seamless asynchronous interface. The RP signal has timing that matches the timing required by asynchronous FIFOs. For clocked FIFO designs like that shown in [Figure 12](#), the ENN input is used to not only read data from a Clocked FIFO like the Cypress CY7C443, but also to latch data into the Transmitter on the next rising edge of CKW.

The receiver has a RDY output that pulses LOW each time new data has been received. The RDY output has timing that allows the receiver to be seamlessly interfaced with both asynchronous and clocked FIFOs as shown in [Figure 11](#) and [Figure 12](#). The TAXI-275 devices require a significant amount of additional circuitry to allow interfacing with FIFOs.

DC Specifications

The maximum current specification of the TAXI-275 Transmitter operating at 27.5 MB/s is 255 mA. The maximum current specification of the HOTLink Transmitter at 33 MB/s is only 80 mA.

The TAXI-275 Receiver requires a maximum of 390 mA to operate at 27.5 MB/s whereas the HOTLink Receiver requires only 150 mA when operating at 33 MB/s.

Figure 10. Built-In Self-Test

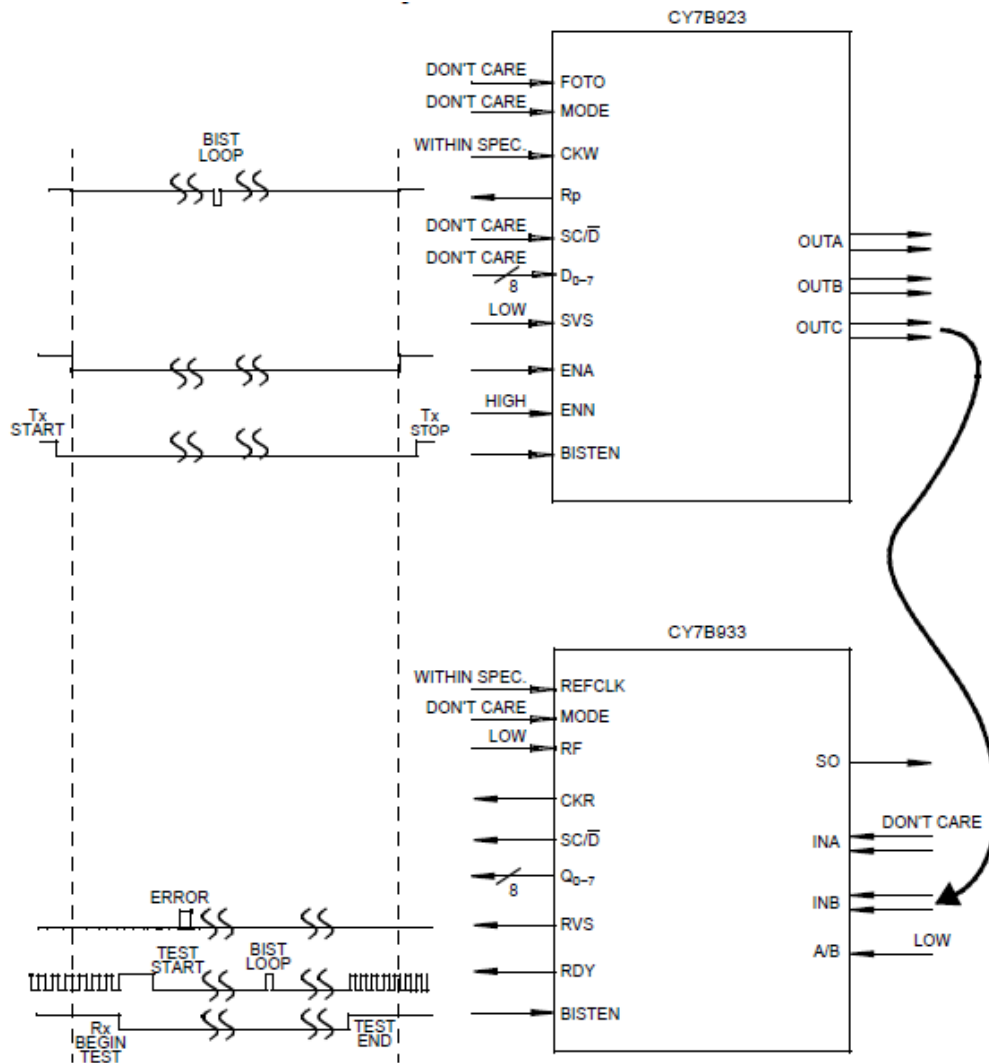

Additionally, the TAXI-275 devices require 100 mV of differential input voltage at the receiver to accurately recover the clock and data from the input serial data stream. The HOTLink Receiver requires only 50 mV of differential input voltage. This translates into lower error rates, increased noise margins, higher jitter tolerance, and longer transmission distances when compared with the TAXI-275 devices.

Sending Violations

In many systems it is important to explicitly send violations. In normal system operation, a violation can be caused by either a received symbol having no corresponding decode value in the receiver, or a valid code received with the wrong RD. It is useful to send violation codes for testing, signaling, and interrupting the receiving system. The TAXI-275 devices have no method of code rule or Running Disparity violations. The HOTLink Transmitter, on the other hand, can send a pattern that will translate into a Code Rule Violation (C0.7) or Running Disparity Violation (C4.7) at the receiver. These Violations are indicated with a HIGH state on the RVS output with a Code Rule Violation indicated with command code C0.7 and a Running Disparity Violation indicated with command code C4.7. In addition, the SVS pin can be used to send a Code Rule Violation with the same indication at the Receiver.

Figure 11. Asynchronous FIFO Interface^(Note 1)

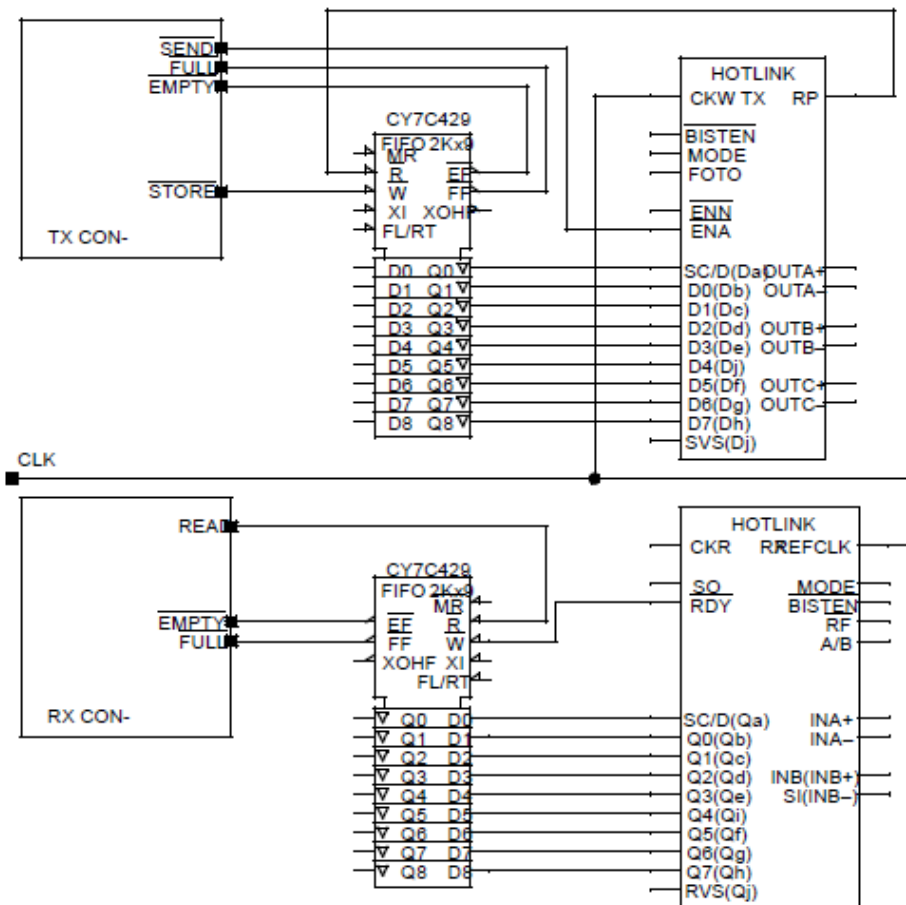

Note 1. CY7C429 (Async FIFO, 2Kx9) is Obsolete. Please check with other vendors for replacement. The drop in replacement offered by Cypress is CY7C421(512x9).

ECL-to-TTL Translator

The TAXI-275 device does not include an ECL-to-TTL translator. The HOTLink Receiver has a built-in ECL-to-TTL translator where the SI input takes the single-ended ECL 100 K (+5 V referenced) signal in and the translated TTL signal is presented at the SO output. The system can utilize this translator to convert an ECL carrier-detect signal from an optical module into its TTL equivalent for use by a controller.

Figure 12. Clocked FIFO Interface ^(Note 2)

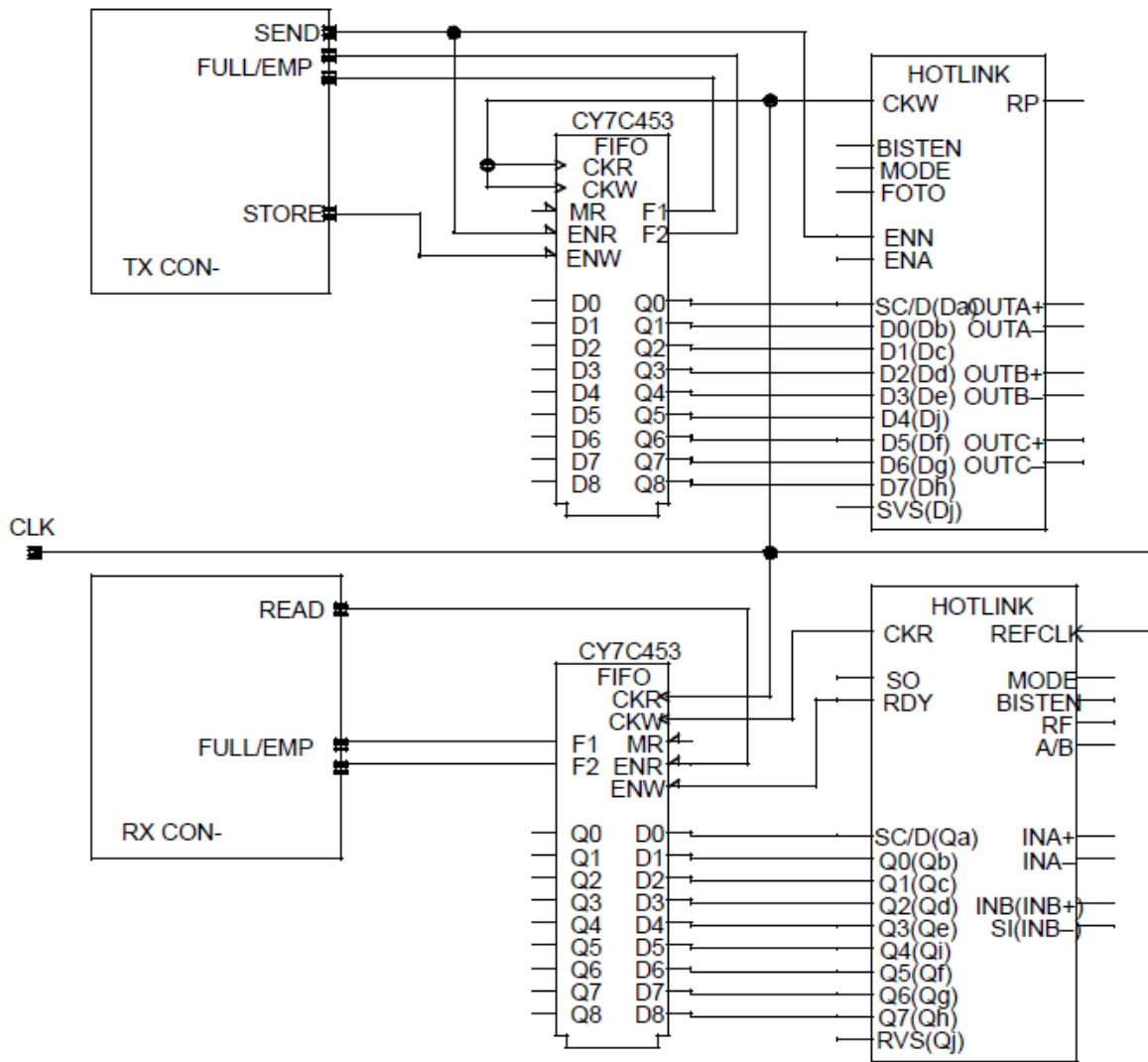

Note 2. CY7C453 (Sync FIFO, 2Kx9) is Obsolete. Please check with other vendors for replacement. The closest replacement offered by Cypress is CY7C4231(2Kx9).

Output Enable Considerations

The TAXI-275 devices use the OE1 and OE2 inputs to force the TX and TY outputs to their logic 0 state. A HIGH on OE1 and a LOW on OE2 will force TX LOW and TY HIGH. The analogous function on HOTLink is implemented with the FOTO pin. When the FOTO pin is held HIGH the OUTA+ and OUTB+ are forced LOW and the OUTA- and OUTB- outputs are forced HIGH. This cause a fiberoptic transmit module to extinguish its light output. The OUTC outputs are unaffected by the FOTO pin so that loop-back testing can be performed while the other outputs are turned off.

When the TAXI-275 OE1 and OE2 are both pulled HIGH, the TX and TY output drivers are turned off. This same result can be accomplished on HOTLink by either pulling both of the outputs of an output pair HIGH or simply leaving them unconnected. This will turn both outputs of an output pair off and save approximately 5 mA per output pair.

Table 3. HOTLink Status Indication

Function	SC/D	RDY	RVS	Q0-7	TAXI Indication
Data	0	0	0	Data	Data
Command	1	0	0	Command	Command
Code Rule Violation	1	0	1	C0.7	S1/S2=01
Running Disparity Violation	1	0	1	C4.7	S1/S2=01
Sync indication after reframe	1	0	1	C5.0	NONE

A Code Rule Violation is indicated with the SC/D pin HIGH, a LOW pulse on the RDY line, a HIGH on the RVS pin, and C0.7 on the data lines. A Code Rule Violation is a 10-bit transmission character that cannot be decoded into an 8-bit symbol. Coding Violations are caused by errors during transmission across the link. A running disparity (RD) Violation is indicated in the same manner on the SC/D, RDY, and RVS pins as a Code Rule Violation, but the data output lines indicate the C4.7 command. A RD Violation is present when a transmission character is able to be decoded into an 8-bit symbol, but the transmission character had the wrong RD.

It is important that these two different types of violations are indicated separately to a controller. A Code Rule Violation indicates that the current symbol is corrupted. In this situation the controller would most probably throw away the erroneous word. A RD Violation, on the other hand, indicates that the current word probably is correct, but that at some point in the past the data became corrupted. In this situation, the controller would probably discard the entire packet.

Status Indication

The TAXI-275 S1 and S2 status pins are used to indicate the status of the parallel output data as shown in Table 2.

Table 2. TAXI-275 Status Indication

Pin Status		Indication
S1	S2	

The Special Character/DATA (SC/D), Ready (RDY), and RVS outputs of HOTLink provide more status information than that provided by the TAXI-275 status pins as shown in Table 3. This table shows that Data and Command signalling on the HOTLink and the TAXI-275 devices are very similar. Violations, however, are indicated very differently between the two devices.

Additionally, HOTLink provides a SYNC indication after entering reframing. When RF is brought high, the RDY line pulses low after the first SYNC character (K28.5) has been received. This feature assists the Reframe state machine in determining when the receiver has been reframed. The Reframe state machine could pull RF LOW after the SYNC indication. This would prevent alias SYNC characters from realigning the receiver. TAXI-275 devices do not have the ability to indicate when data has been framed to a K28.5.

The TAXI-275 devices only have an indication that the receiver was realigned (S1, S2 = 11). The status lines do not always indicate if the TAXI-275 Receiver has reframed when SYNC is LOW. Only if the byte boundary has changed will the status pins change. A reframe controller, therefore, must monitor all of the command lines to determine if the receiver has correctly framed on the data stream. This complicates reframe state machine design.

Summary

HOTLink has many advantages when compared with the AMD Am79168 Transmitter and Am79169 Receiver (TAXI). These advantages include those listed below.

- Multiplexed command and data
- Three differential serial outputs
- Two differential serial inputs
- More flexible Command codes
- More flexible reframing
- Higher operating frequency
- Built-In Self-Test
- Simplified synchronous interface
- Reduced power consumption
- Ability to send violations
- Simplified output enable interface
- More complete receiver status indications
- ECL-to-TTL translator

These advantages of HOTLink provide greater system flexibility, simplified controller design, more reliable data communication, and lower power consumption.

References

1. Cypress Semiconductor, *CY7B923/CY7B933 HOTLink Transmitter/Receiver Preliminary Data Sheet*, Cypress Semiconductor High Performance Data Book, August 1, 1993.
2. Cypress Semiconductor, *HOTLink Design Considerations* Application Note, October 1993.
3. Advanced Micro Devices, *Am79168/ Am79169-275 TAXI-275 Integrated Circuits Technical Manual*, Rev. 1.0, 1993.
4. Advanced Micro Devices, *Am79168/ Am79169-275 TAXI-275 Transmitter/Receiver Transparent Asynchronous Transmitter/Receiver Interface Preliminary Data Sheet*, March 1993 Rev. B.

Document History

Document Title: AN1038 - Upgrade Your TAXI-275 with HOTLink®

Document Number: 001-41319

Revision	ECN	Orig. of Change	Submission Date	Description of Change
**	1540365	SAAC	10/03/2007	New spec.
*A	3390243	SAAC	09/30/2011	Minor text edits. Updated to new template.
*B	4574197	YLIU	11/19/2014	Updated to new template. Completing Sunset Review.
*C	5881070	AESATMP8	09/12/2017	Updated logo and Copyright.

Worldwide Sales and Design Support

Cypress maintains a worldwide network of offices, solution centers, manufacturer's representatives, and distributors. To find the office closest to you, visit us at [Cypress Locations](#).

Products

ARM® Cortex® Microcontrollers	cypress.com/arm
Automotive	cypress.com/automotive
Clocks & Buffers	cypress.com/clocks
Interface	cypress.com/interface
Internet of Things	cypress.com/iot
Memory	cypress.com/memory
Microcontrollers	cypress.com/mcu
PSoC	cypress.com/psoc
Power Management ICs	cypress.com/pmics
Touch Sensing	cypress.com/touch
USB Controllers	cypress.com/usb
Wireless Connectivity	cypress.com/wireless

PSoC® Solutions

[PSoC 1](#) | [PSoC 3](#) | [PSoC 4](#) | [PSoC 5LP](#) | [PSoC 6](#)

Cypress Developer Community

[Forums](#) | [WICED IOT Forums](#) | [Projects](#) | [Videos](#) | [Blogs](#) | [Training](#) | [Components](#)

Technical Support

cypress.com/support

All other trademarks or registered trademarks referenced herein are the property of their respective owners.



Cypress Semiconductor
198 Champion Court
San Jose, CA 95134-1709

© Cypress Semiconductor Corporation, 2007-2017. This document is the property of Cypress Semiconductor Corporation and its subsidiaries, including Spansion LLC ("Cypress"). This document, including any software or firmware included or referenced in this document ("Software"), is owned by Cypress under the intellectual property laws and treaties of the United States and other countries worldwide. Cypress reserves all rights under such laws and treaties and does not, except as specifically stated in this paragraph, grant any license under its patents, copyrights, trademarks, or other intellectual property rights. If the Software is not accompanied by a license agreement and you do not otherwise have a written agreement with Cypress governing the use of the Software, then Cypress hereby grants you a personal, non-exclusive, nontransferable license (without the right to sublicense) (1) under its copyright rights in the Software (a) for Software provided in source code form, to modify and reproduce the Software solely for use with Cypress hardware products, only internally within your organization, and (b) to distribute the Software in binary code form externally to end users (either directly or indirectly through resellers and distributors), solely for use on Cypress hardware product units, and (2) under those claims of Cypress's patents that are infringed by the Software (as provided by Cypress, unmodified) to make, use, distribute, and import the Software solely for use with Cypress hardware products. Any other use, reproduction, modification, translation, or compilation of the Software is prohibited.

TO THE EXTENT PERMITTED BY APPLICABLE LAW, CYPRESS MAKES NO WARRANTY OF ANY KIND, EXPRESS OR IMPLIED, WITH REGARD TO THIS DOCUMENT OR ANY SOFTWARE OR ACCOMPANYING HARDWARE, INCLUDING, BUT NOT LIMITED TO, THE IMPLIED WARRANTIES OF MERCHANTABILITY AND FITNESS FOR A PARTICULAR PURPOSE. To the extent permitted by applicable law, Cypress reserves the right to make changes to this document without further notice. Cypress does not assume any liability arising out of the application or use of any product or circuit described in this document. Any information provided in this document, including any sample design information or programming code, is provided only for reference purposes. It is the responsibility of the user of this document to properly design, program, and test the functionality and safety of any application made of this information and any resulting product. Cypress products are not designed, intended, or authorized for use as critical components in systems designed or intended for the operation of weapons, weapons systems, nuclear installations, life-support devices or systems, other medical devices or systems (including resuscitation equipment and surgical implants), pollution control or hazardous substances management, or other uses where the failure of the device or system could cause personal injury, death, or property damage ("Unintended Uses"). A critical component is any component of a device or system whose failure to perform can be reasonably expected to cause the failure of the device or system, or to affect its safety or effectiveness. Cypress is not liable, in whole or in part, and you shall and hereby do release Cypress from any claim, damage, or other liability arising from or related to all Unintended Uses of Cypress products. You shall indemnify and hold Cypress harmless from and against all claims, costs, damages, and other liabilities, including claims for personal injury or death, arising from or related to any Unintended Uses of Cypress products.

Cypress, the Cypress logo, Spansion, the Spansion logo, and combinations thereof, WICED, PSoC, CapSense, EZ-USB, F-RAM, and Traveo are trademarks or registered trademarks of Cypress in the United States and other countries. For a more complete list of Cypress trademarks, visit cypress.com. Other names and brands may be claimed as property of their respective owners.