

## TLE 6361G - Step Down VR, V-Tracker, SPI-Interface

### Connectors & Ports:

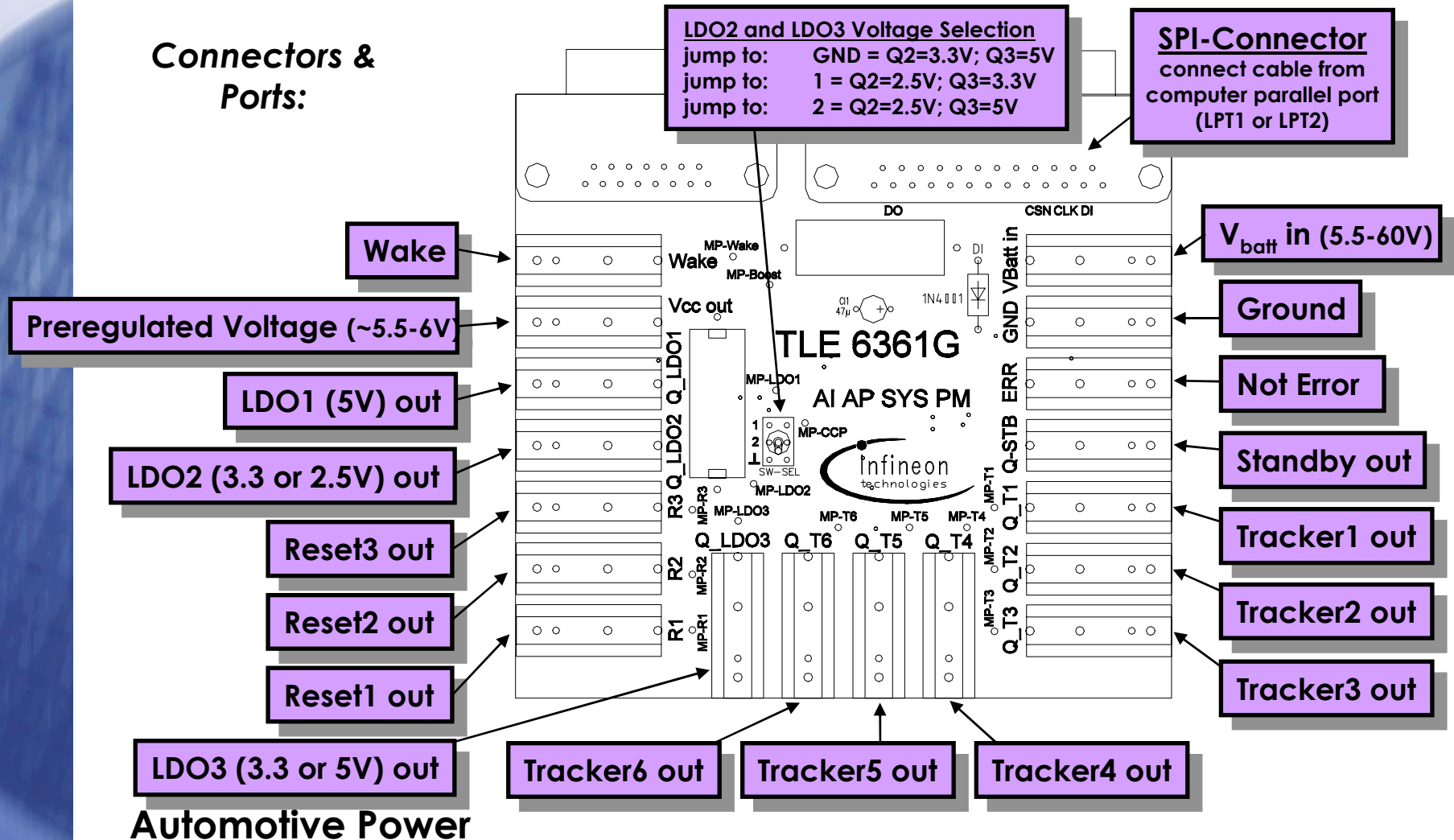

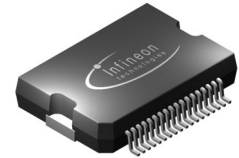

## TLE 6361G - Step Down VR, V-Tracker, SPI-Interface

**Mounting Diagram  
Upper Side:**

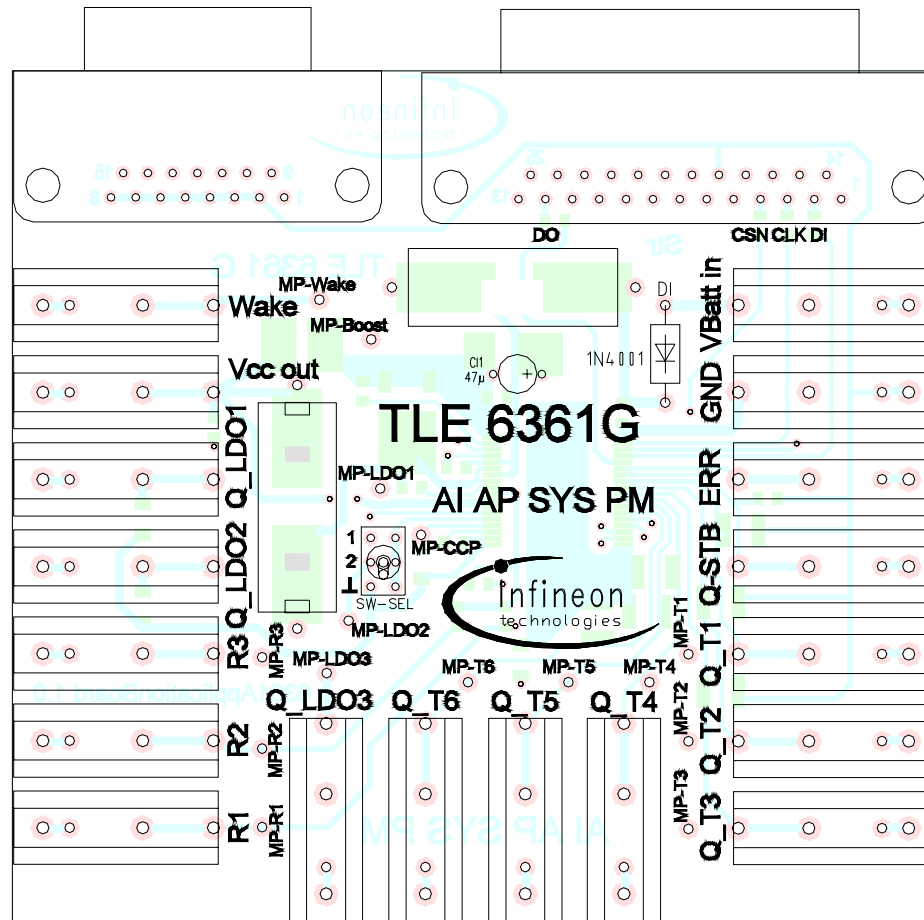

**Automotive Power**

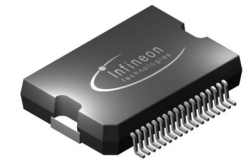

## TLE 6361G - Step Down VR, V-Tracker, SPI-Interface

### Monting-Diagram Bottom Side:

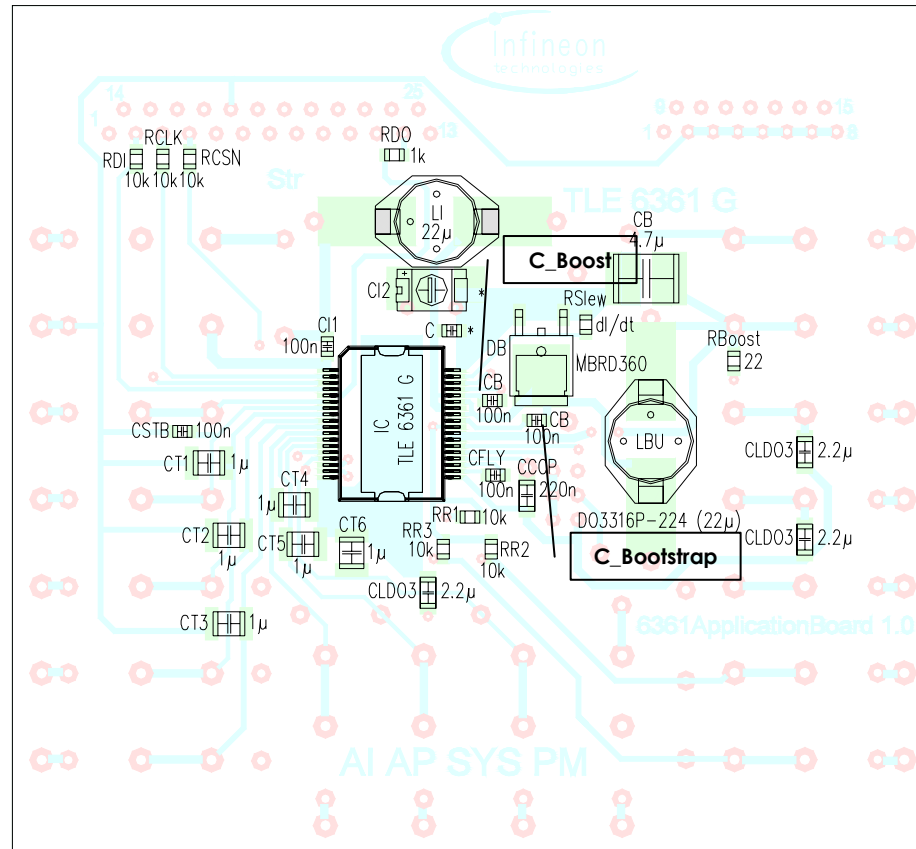



## TLE 6361G - Step Down VR, V-Tracker, SPI-Interface

Circuit Diagram:

