

2ED2772S01G

160 V half bridge SOI gate driver with integrated bootstrap diode

Features

- Bootstrap voltage (VB node) of +160 V
- Floating channel designed for bootstrap operation
- Integrated low R_{ON} , ultra-fast bootstrap diodes
- Independent under voltage lockout for both high and low side
- Integrated shoot-through protection with built-in dead time
- Integrated short pulse / noise rejection input filter
- Schmitt trigger inputs with hysteresis
- 3.3 V, 5 V input logic compatible, outputs in phase with inputs
- Available in small footprint VSON-10 lead, 3 x 3 mm package
- 2.5 kV HBM ESD, RoHS compliant

Applications

General purpose half bridge gate driver for N-Channel MOSFETs

- Servo Drives in Robotics and Factory Automation
- General Purpose Low Voltage Drives or inverters
- e-Scooters, e-Bikes, and other e-Vehicles that do not require Automotive Qualification (LSEV)
- Battery operated Small Home Appliances (SHA)
- Commercial and Agricultural Drones
- Professional and Consumer Service Robotics
- Logistics Vehicles (eForklifts, Autonomous warehouse robotics)
- Battery operated hand-held power tools
- Gardening or Outdoor Power Equipment (OPE) Tools

Product validation

Qualified for industrial applications according to the relevant tests of JEDEC78/20/22

Ordering information

Base part number	Package type	Standard pack		Orderable part number
		Form	Quantity	
2ED2772S01G	3x3 mm VSON-10	Tape and Reel	3000	2ED2772S01GXUMA1

Product summary

$V_{B_OFFSET} = 160 \text{ V max}$
 $I_{O+_pk} / I_{O-_pk} \text{ (typ)} = + 1 \text{ A} / - 2 \text{ A}$
 Deadtime (typ) = 30 ns
 $t_{ON} / t_{OFF} \text{ (typ)} = 50 \text{ ns} / 50 \text{ ns}$
 Delay matching = 15 ns max

Package



VSON-10
3 x 3mm

1 Description

The 2ED2772S01G is a 160 V SOI based gate driver designed for half bridge BLDC motor drive applications. Integrated bootstrap diodes are used to supply the external high side bootstrap capacitor. Protection features include under voltage lockout on both Vcc and VB pins. The output drivers feature a high-pulse current buffer stage designed for minimum driver cross-conduction

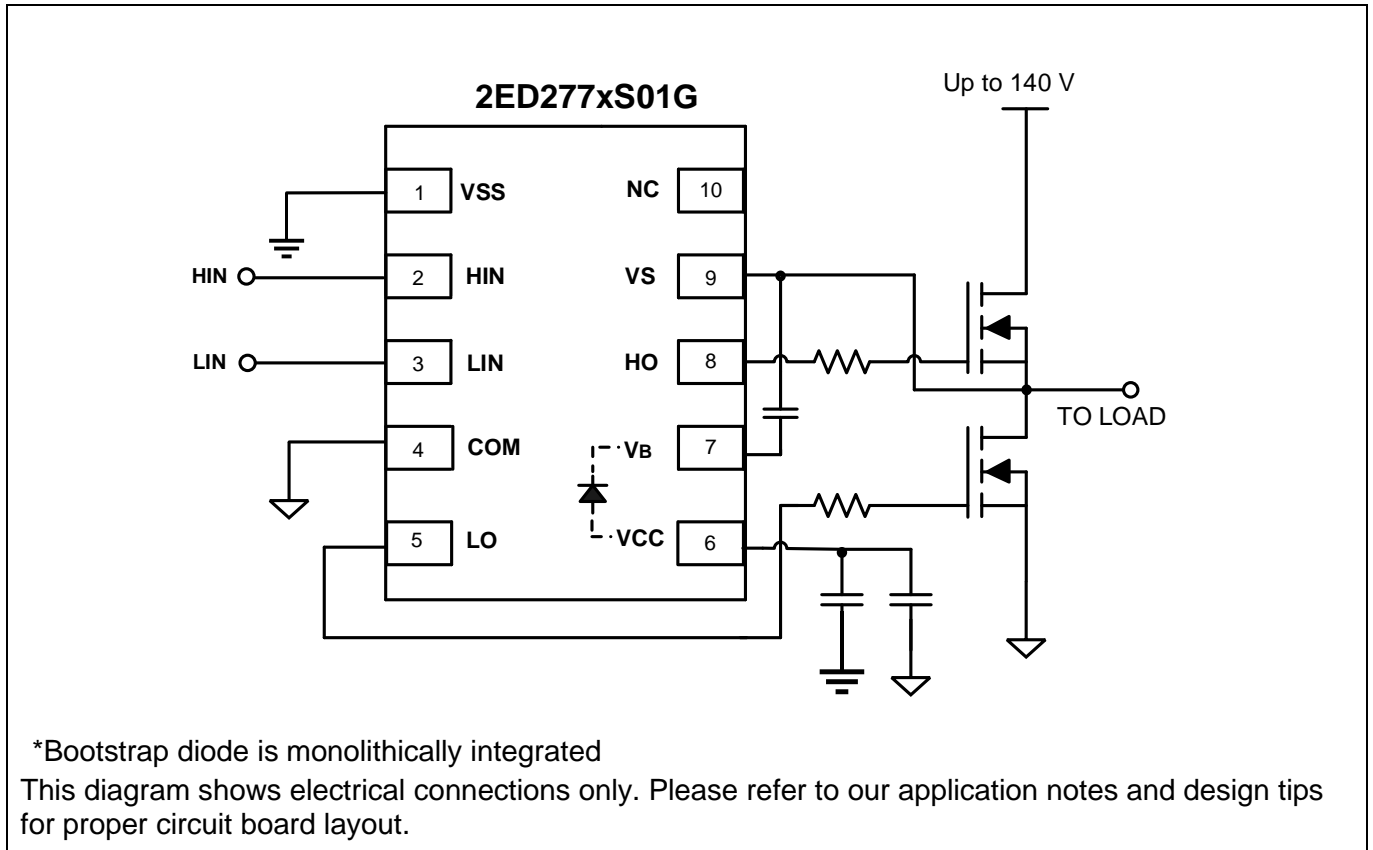

Figure 1 Typical application block diagram

Summary of feature comparison of the 2ED27xxS01G family:

Table 1

Part No.	Package	Drive current source / sink	Input logic	Cross conduction prevention logic	Deadtime	Ground pins	t _{ON} / t _{OFF}
2ED2732S01G	VSON-10 3 x 3 mm	+ 1 A / - 2 A	HIN, LIN	No	None	VSS / COM	50 ns / 50 ns
2ED2734S01G		+ 2 A / - 4 A					65 ns / 65 ns
2ED2738S01G		+ 4 A / - 8 A					65 ns / 65 ns
2ED2772S01G		+ 1 A / - 2 A					50 ns / 50 ns
2ED2772S01G		+ 1 A / - 2 A		50 ns / 50 ns			
2ED2744S01G		+ 2 A / - 4 A		65 ns / 65 ns			
2ED2748S01G		+ 4 A / - 8 A		65 ns / 65 ns			
2ED2778S01G		+ 4 A / - 8 A		65 ns / 65 ns			

2 Table of contents

Features	Product summary	1
Applications		1
Product validation		1
Ordering information		1
1	Description	2
2	Table of contents	3
3	Electrical parameters	4
3.1	Absolute maximum ratings	4
3.2	Recommended operating conditions	5
3.3	Static electrical characteristics	5
3.4	Dynamic electrical characteristics	7
4	Block diagram	8
5	Pin configuration and functionality	9
5.1	Pin configuration	9
6	Application information and additional details	10
6.1	MOSFET gate drive	10
6.2	Switching relationships	10
6.3	Timing diagrams	11
6.4	Deadtime and matched propagation delays	11
6.5	Input logic compatibility	12
6.6	Undervoltage lockout	13
6.7	Shoot-through protection	13
6.8	Bootstrap diode	14
6.9	Calculating the bootstrap capacitance C_{BS}	15
6.10	Negative voltage transient tolerance of VS pin	16
6.11	PCB layout tips	18
7	Qualification information	20
8	Related products	20
9	Packaging information	21
10	Additional documentation and resources	22
10.1	Infineon online forum resources	22
11	Revision history	22

3 Electrical parameters

3.1 Absolute maximum ratings

Absolute maximum ratings indicate sustained limits beyond which damage to the device may occur. All voltage parameters are absolute voltages referenced to VSS unless otherwise stated in the table. The thermal resistance and power dissipation ratings are measured under board mounted and still air conditions.

Table 2 Absolute maximum ratings

Symbol	Definition	Min.	Max.	Units
V_B	High-side floating well supply voltage (Note 1)	-0.3	160	V
V_S	High-side floating well supply return voltage	-0.3	140	
V_{BS}	High-side floating well supply voltage	-0.3	20	
V_{HO}	Floating gate drive output voltage	$V_S - 0.3$	$V_{BS} + 0.3$	
V_{CC}	Low side supply voltage	-0.3	20	
V_{LO}	Low-side output voltage	COM - 0.3	$V_{CC} + 0.3$	
$V_{LOGIC IN}$	Logic input voltage (HIN, LIN)	$V_{SS} - 0.3$	5	
COM	Low side power ground return	-5.0	+5.0	
dV_S/dt	Allowable V_S offset supply transient relative to COM	—	50	V / ns
P_D	Package power dissipation @ $T_A \leq +25^\circ\text{C}$ VSON-10		2	W
R_{thJA}	Thermal resistance, junction to ambient VSON-10		57	$^\circ\text{C}/\text{W}$
T_J	Junction temperature	—	150	$^\circ\text{C}$
T_S	Storage temperature	- 50	150	
T_L	Lead temperature (soldering, 10 seconds)	—	260	

Note 1: In case $V_{CC} > V_B$ there is an additional power dissipation in the internal bootstrap diode between pins VCC and V_B .

3.2 Recommended operating conditions

For proper operation, the device should be used within the recommended conditions. All voltage parameters are absolute voltages referenced to VSS unless otherwise stated in Table 2. Recommended operating conditions

Table 3 Recommended operating conditions

Symbol	Definition	Min	Max	Units
V _B	Bootstrap voltage	V _S + 7	140	V
V _{BS}	High-side floating well supply voltage	7	18	
V _S	High-side floating well supply offset voltage	0	122	
V _{HO}	Floating gate drive output voltage	V _S	V _B	
V _{CC}	Low-side supply voltage	7	18	
V _{LO}	Low-side output voltage	COM	V _{CC}	
V _{LOGIC IN}	Logic input voltage(HIN, LIN)	V _{SS}	5	
T _A	Ambient temperature	-40	125	°C

3.3 Static electrical characteristics

(V_{CC} – COM) = (V_B – V_S) = 12 V, V_{SS} = COM and T_A = 25 °C unless otherwise specified. The V_{IL}, V_{IH} and I_{IN} parameters are referenced to V_{SS} and are applicable to the respective input leads: HIN and LIN. The V_O and I_O parameters are referenced to V_{SS} and are applicable to the respective output leads HO or LO. The V_{CCUV} parameters are referenced to V_{SS}. The V_{BSUV} parameters are referenced to V_S.

Table 4 Static electrical characteristic

Symbol	Definition	Min.	Typ.	Max.	Units	Test Conditions
V _{CCUVLO+}	V _{CC} supply undervoltage positive going threshold	7.8	8.2	8.6	V	
V _{CCUVLO-}	V _{CC} supply undervoltage negative going threshold	7.3	7.7	8.1		
V _{CCUVLOHY}	V _{CC} supply undervoltage hysteresis	0.3	0.5	0.7		
V _{BSUVLO+}	V _{BS} supply undervoltage positive going threshold	7.8	8.2	8.6		
V _{BSUVLO-}	V _{BS} supply undervoltage negative going threshold	7.3	7.7	8.1		
V _{BSUVLOHY}	V _{BS} supply undervoltage hysteresis	0.3	0.5	0.7		
I _{LK}	High-side floating well offset supply leakage	—	—	5	uA	V _B = V _S = 140 V
I _{QCC}	Quiescent supply current	—	85	150		
V _{OH}	High level output voltage drop,	—	0.54	—	V	I _O = 100 mA

Symbol	Definition	Min.	Typ.	Max.	Units	Test Conditions
V_{OL}	Low level output voltage drop	—	0.14	—		$I_O = 100 \text{ mA}$
I_{o+}	Peak output current turn-on ¹	—	1	—	A	$PW \leq 10 \mu\text{s}$
I_{o-}	Peak output current turn-off ¹	—	2	—		$PW \leq 10 \mu\text{s}$
V_{IH}	Logic "1" input voltage	2.0	—	—	V	
V_{IL}	Logic "0" input voltage	—	—	0.8		
$I_{LOGIC IN+}$	Input bias current (Output = High)	—	25	50	μA	$V_{IN} = 4 \text{ V}$
$I_{LOGIC IN-}$	Input bias current (Output = Low)	—	—	2		$V_{IN} = 0 \text{ V}$
V_{FBSD}	Bootstrap diode forward voltage between V_{CC} and V_B	0.6	0.8	1	V	$I_F = 0.3 \text{ mA}$
I_{FBSD}	Bootstrap diode forward current between V_{CC} and V_B	88	111	133	mA	$V_{CC} - V_B = 4 \text{ V}$
R_{BSD}	Bootstrap diode resistance	15	21	31	Ω	$V_{F1} = 4 \text{ V}, V_{F2} = 5 \text{ V}$

¹ Not subjected to production test, verified by characterization.

3.4 Dynamic electrical characteristics

$V_{CC} = V_{BS} = 12\text{ V}$, $V_{SS} = \text{COM}$, $T_A = 25\text{ °C}$ and $C_L = 1000\text{ pF}$ unless otherwise specified.

Table 5 Dynamic electrical characteristics

Symbol	Definition	Min.	Typ.	Max.	Units	Test Conditions
t_{ON}	Turn-on propagation delay	20	50	90	ns	Load = 1nF, IN 50% rise to OUT 10% rise Load = 1nF, IN 50% fall to OUT 90% fall
t_{OFF}	Turn-off propagation delay	20	50	90		
t_R	Turn-on rise time	10	20	30		Load = 1nF, OUT 10% to OUT 90% Load = 1nF, OUT 90% to OUT 10%
t_F	Turn-off fall time	7	15	20		
MT	Delay matching time (HS & LS turn-on/off)	—	—	15		Load = 1nF, OUT 90% to OUT 10%
DT	Deadtime: LO Turn-off to HO Turn-on & HO Turn-off to LO turn-on	15	30	45		

4 Block diagram

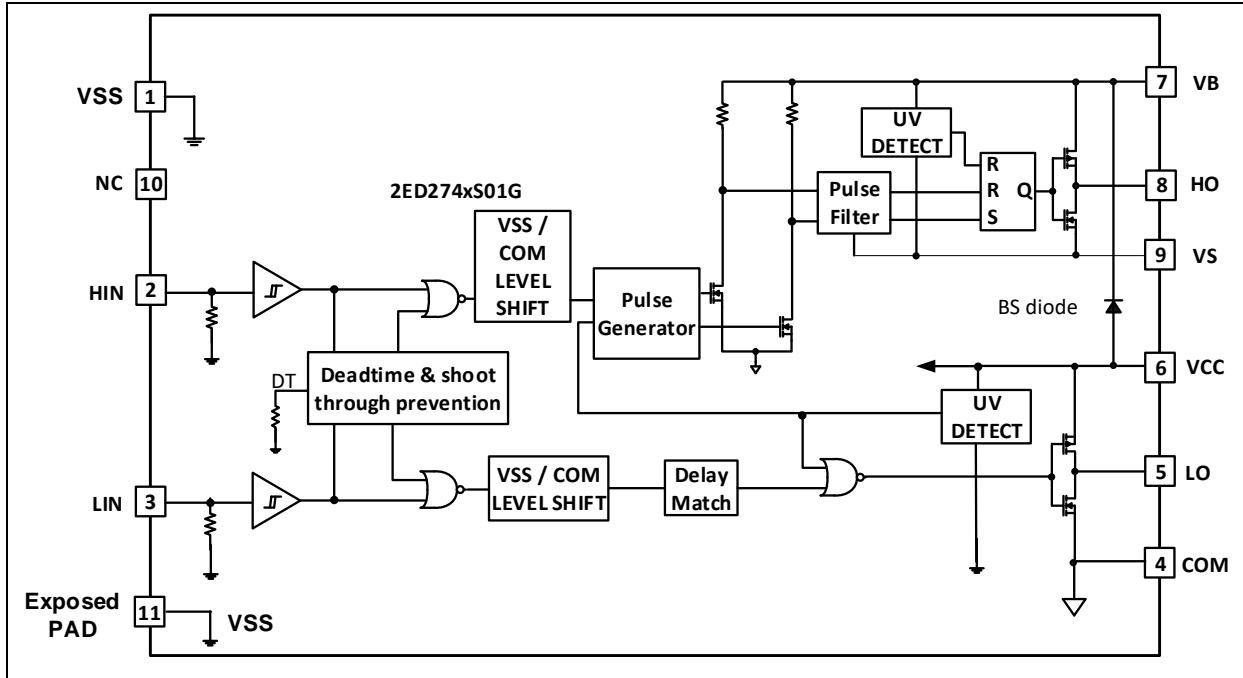

Figure 2 Functional block diagram

5 Pin configuration and functionality

5.1 Pin configuration

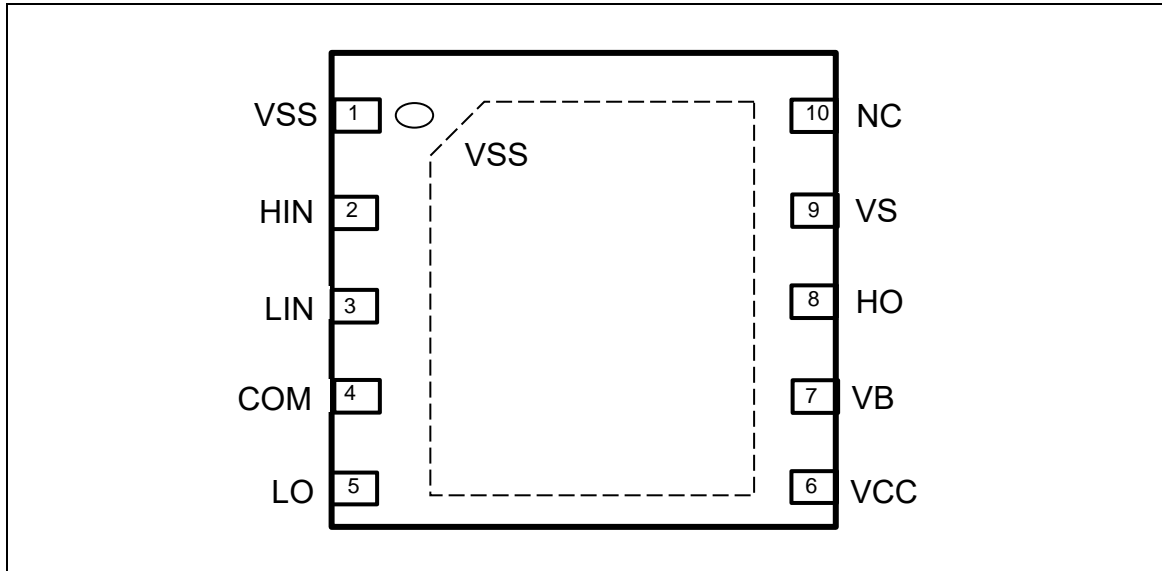

Figure 3 2ED2772S01G pin assignments (top view)

Pin functionality

Table 6 Pin descriptions

Symbol	Pin No.	Type	Description
VSS	1	Ground	Logic ground
HIN	2	Input	Logic input for high side gate driver output (HO), in phase
LIN	3	Input	Logic input for low side gate driver output (LO), in phase
COM	4	Ground	Low side power ground return
LO	5	Output	Low side gate drive outputs
VCC	6	Input	Low side and logic fixed supply
VB	7	Output	High side floating supplies
HO	8	Output	High side gate drive outputs
VS	9	Input	High side floating supply returns
NC	10	NC	Not Connected
VSS	11	Exposed PAD	Logic ground

6 Application information and additional details

6.1 MOSFET gate drive

The 2ED2772S01G HVIC is designed to drive MOSFET power devices in battery operated applications. Figures 4 and 5 illustrate several parameters associated with the gate drive functionality of the HVIC. The output current of the HVIC, used to drive the gate of the power switch, is defined as I_{O+} . The voltage that drives the gate of the external power switch is defined as V_{HO} for the high-side power switch and V_{LO} for the low-side power switch; this parameter is sometimes generically called V_{OUT} and in this case does not differentiate between the high-side or low-side output voltage.

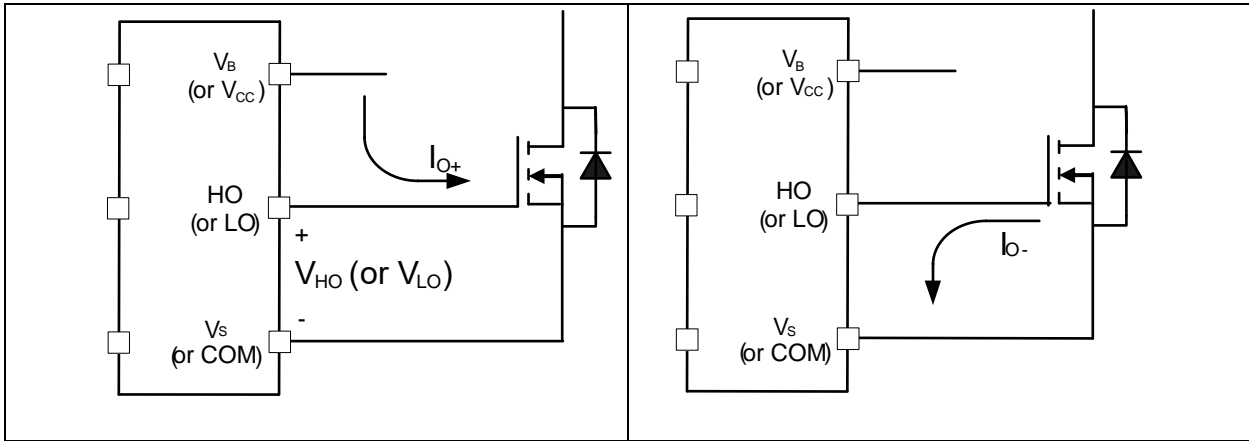

Figure 4 HVIC Sourcing current

Figure 5 HVIC Sinking current

6.2 Switching relationships

The relationships between the input and output signals of the 2ED2772S01G are illustrated below in Figure 6. We can see the definitions of several timing parameters (i.e. t_{ON} , t_{OFF} , t_R , and t_F) associated with this device.

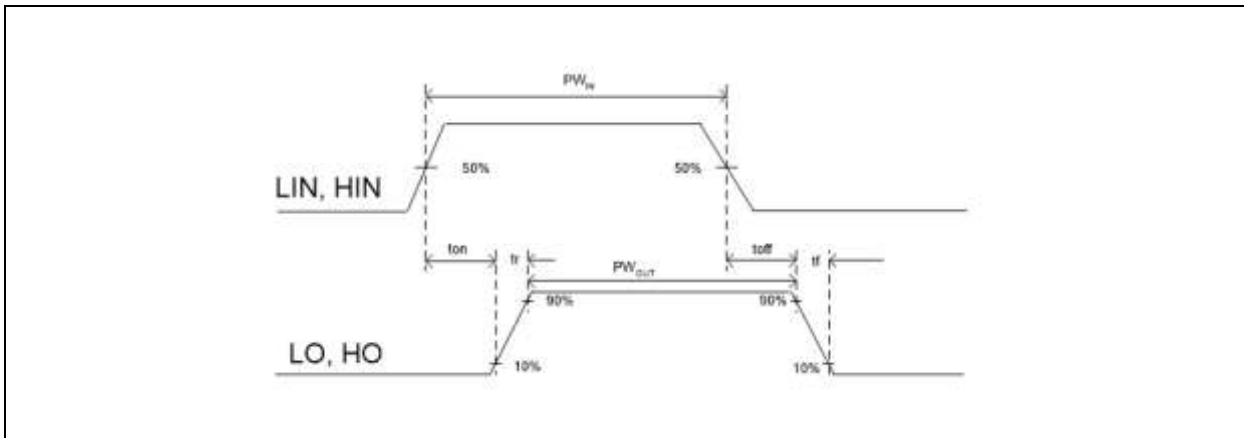

Figure 6 Switching timing diagram

6.3 Timing diagrams

The relationships between the input and output signals of the 2ED2772S01G are illustrated below in Figure 7.

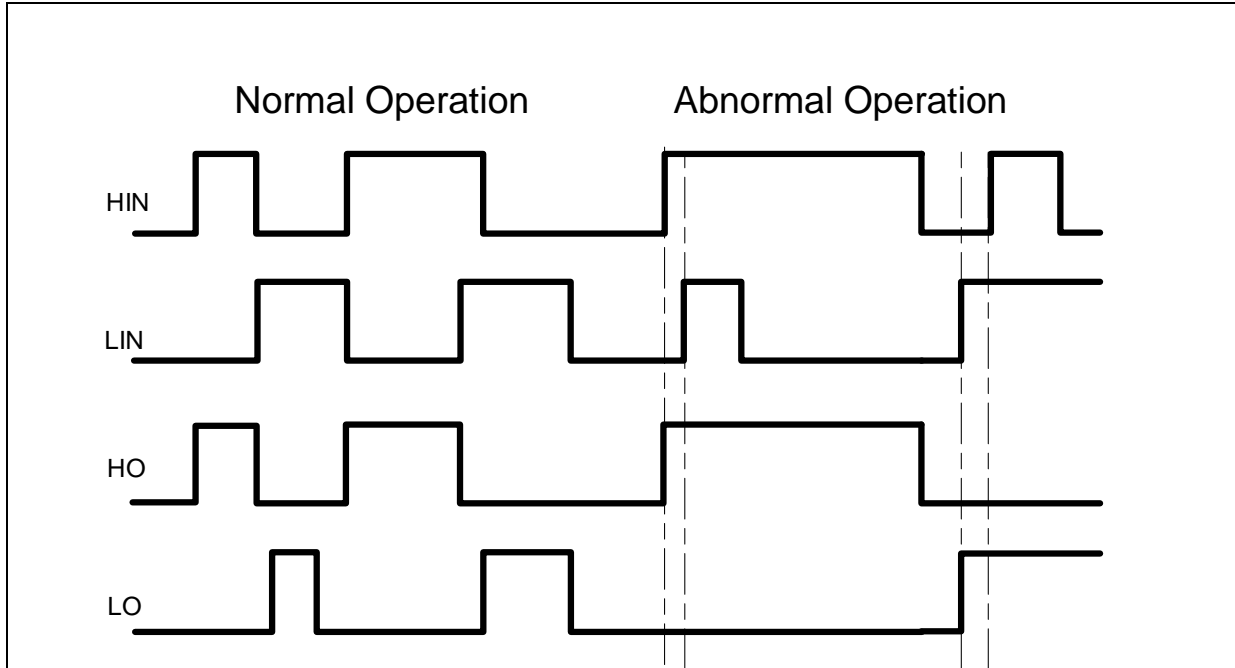

Figure 7 Input/output timing diagram

6.4 Deadtime and matched propagation delays

This 2ED2772S01G features integrated deadtime protection circuitry. The deadtime feature inserts a time period (a minimum deadtime) in which both the high- and low-side power switches are held off; this is done to ensure that the power switch being turned off has fully turned off before the second power switch is turned on. This minimum deadtime is automatically inserted whenever the external deadtime is shorter than DT; external deadtimes larger than DT are not modified by the gate driver. Figure 8 illustrates the deadtime period and the relationship between the output gate signals.

The deadtime circuitry of 2ED2772S01G is matched with respect to the high- and low-side outputs. Figure 8 defines the two deadtime parameters (i.e., DTLO-HO and DTHO-LO); the deadtime matching parameter (MDT) associated with the 2ED2772S01G specifies the maximum difference between DTLO-HO and DTHO-LO.

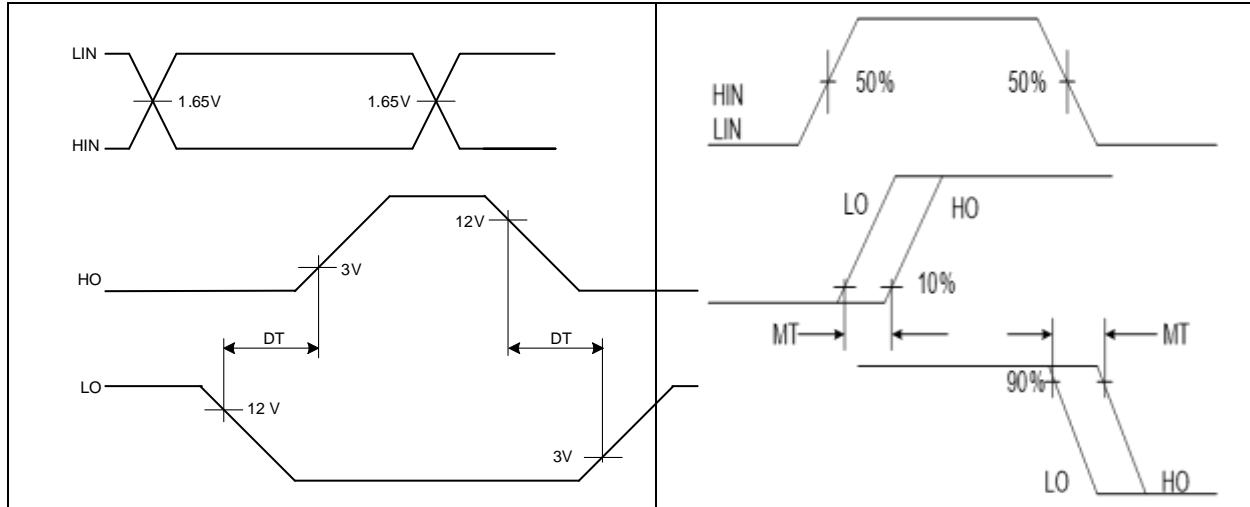

Figure 8 Dead Time Definitions

Figure 9 Delay Matching Waveform Definitions

The 2ED2772S01G is designed with propagation delay matching circuitry. With this feature, the IC's response at the output to a signal at the input requires approximately the same time duration (i.e., t_{ON} , t_{OFF}) for both the low-side channels and the high-side channels; the maximum difference is specified by the delay matching parameter (MT). The propagation turn-on delay (t_{ON}) of the 2ED2772S01G is matched to the propagation turn-off delay (t_{OFF}).

6.5 Input logic compatibility

The input pins of are based on a TTL and CMOS compatible input-threshold logic that is independent of the V_{CC} supply voltage. With typical high threshold (V_{IH}) of 2.0 V and typical low threshold (V_{IL}) of 0.8 V, along with very little temperature variation as summarized in Figure 10, the input pins are conveniently driven with logic level PWM control signals derived from 3.3 V and 5 V digital power-controller devices. Wider hysteresis (typically 0.8 V) offers enhanced noise immunity compared to traditional TTL logic implementations, where the hysteresis is typically less than 0.5 V. 2ED2772S01G also features tight control of the input pin threshold voltage levels which eases system design considerations and ensures stable operation across temperature. The 2ED2772S01G features floating input protection wherein if any of the input pin is left floating, the output of the corresponding stage is held in the low state. This is achieved using pull-down resistors on all the input pins (HIN, LIN) as shown in the block diagram. The 2ED2772S01G has input pins that are capable of sustaining voltages higher than the bias voltage applied on the V_{CC} pin of the device.

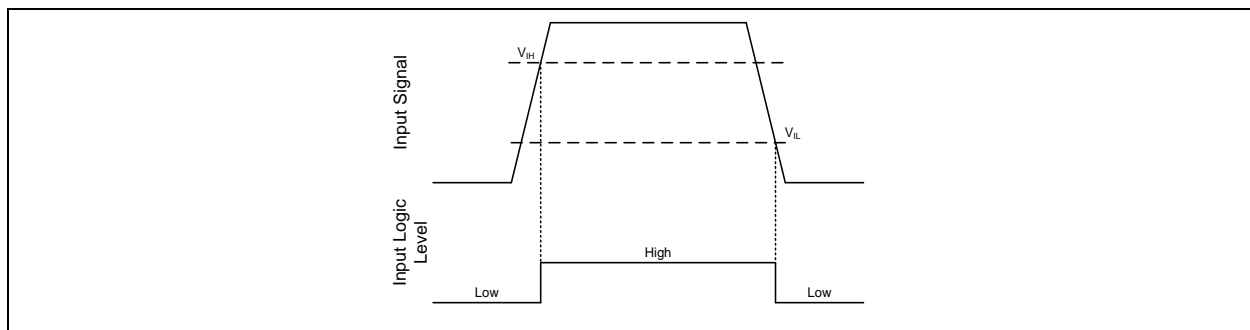

Figure 10 HIN & LIN input thresholds

6.6 Undervoltage lockout

This IC provides undervoltage lockout protection on both the V_{CC} (logic and low-side circuitry) power supply and the V_{BS} (high-side circuitry) power supply. Figure 11 is used to illustrate this concept; V_{CC} (or V_{BS}) is plotted over time and as the waveform crosses the UVLO threshold ($V_{CC\text{UVLO+/-}}$ or $V_{BS\text{UVLO+/-}}$) the undervoltage protection is enabled or disabled.

Upon power-up, should the V_{CC} voltage fail to reach the $V_{CC\text{UV+}}$ threshold, the IC won't turn-on. Additionally, if the V_{CC} voltage decreases below the $V_{CC\text{UV-}}$ threshold during operation, the undervoltage lockout circuitry will recognize a fault condition and shutdown the high and low-side gate drive outputs.

Upon power-up, should the V_{BS} voltage fail to reach the $V_{BS\text{UV+}}$ threshold, the IC won't turn-on. Additionally, if the V_{BS} voltage decreases below the $V_{BS\text{UVLO-}}$ threshold during operation, the undervoltage lockout circuitry will recognize a fault condition, and shutdown the high-side gate drive outputs of the IC.

The UVLO protection ensures that the IC drives the external power devices only when the gate supply voltage is sufficient to fully enhance the power devices. Without this feature, the gates of the external power switch could be driven with a low voltage, resulting in the power switch conducting current while the channel impedance is high; this could result in very high conduction losses within the power device and could lead to power device failure.

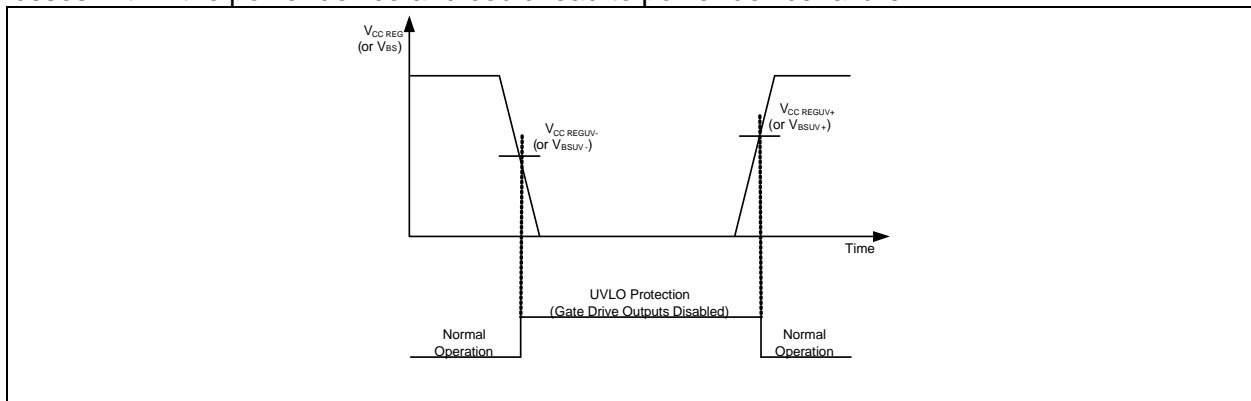

Figure 11 UVLO protection

6.7 Shoot-through protection

The 2ED2772S01G is equipped with shoot-through protection circuitry (also known as cross-conduction prevention circuitry). Figure 12 shows how this protection circuitry prevents both the high- and low-side switches from conducting at the same time.

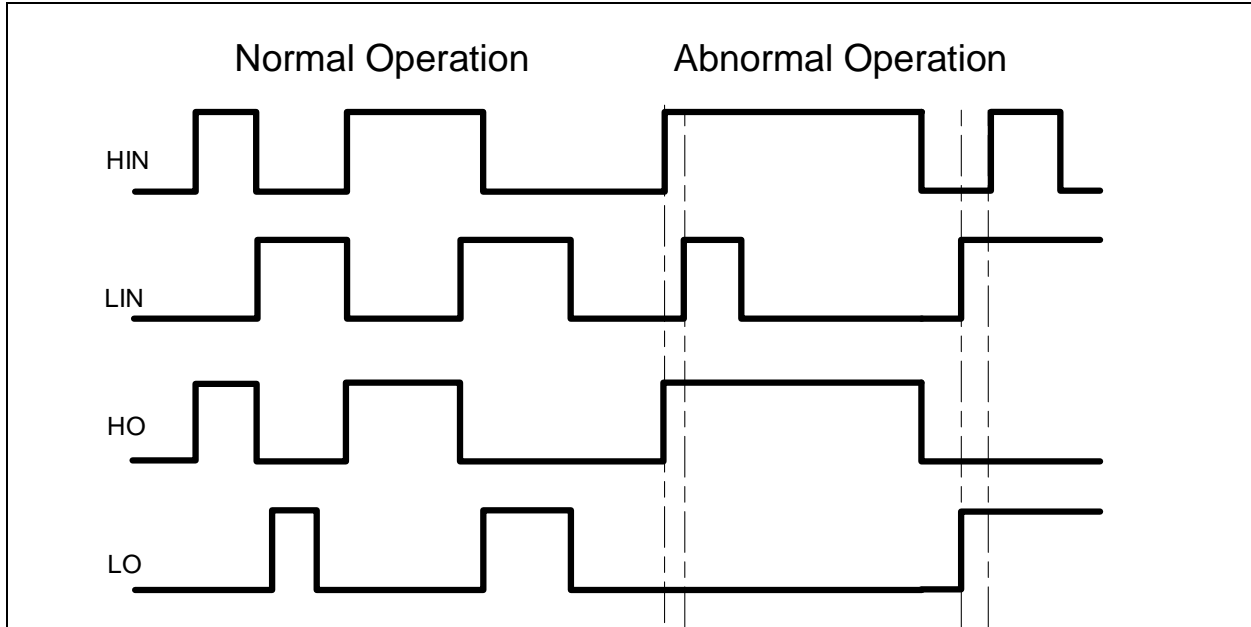

Figure 12 Illustration of shoot-through protection circuitry

6.8 Bootstrap diode

An ultra-fast bootstrap diode is monolithically integrated for establishing the high side supply. The differential resistor of the diode helps to avoid extremely high inrush currents when initially charging the bootstrap capacitor. The integrated diode with its low ohmic resistance helps save cost and improve reliability by reducing external components as shown below figure 13.

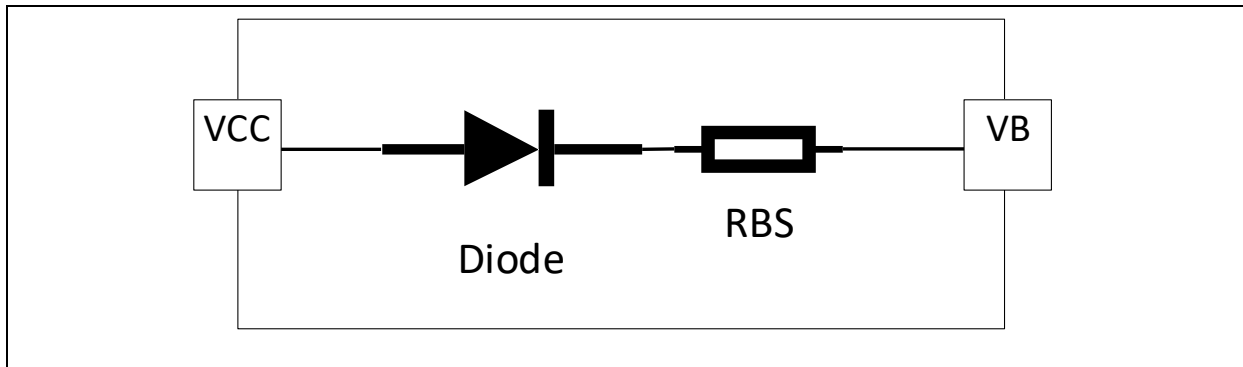

Figure 13 2ED2772S01G with integrated components

The low ohmic current limiting resistor (typically 25 Ohms) provides essential advantages over other competitor devices with high ohmic bootstrap structures. A low ohmic resistor such as in the 2ED2772S01G allows faster recharging of the bootstrap capacitor during periods of small duty cycles on the low side transistor. The bootstrap diode is usable for all kind power electronic converters. The bootstrap diode is a real uni-directional PN-diode and is temperature robust. It can be used at high temperatures with a low duty cycle of the low side transistor.

The bootstrap diode of the 2ED2772S01G works with all control algorithms of modern power electronics, such as trapezoidal or sinusoidal motor drives control.

6.9 Calculating the bootstrap capacitance C_{BS}

Bootstrapping is a common method of pumping charges from a low potential to a higher one. With this technique a supply voltage for the floating high side sections of the gate drive can be easily established according to Figure 14. This method has the advantage of being simple and low cost but may force some limitations on duty-cycle and on-time since they are limited by the requirement to refresh the charge in the bootstrap capacitor. Proper capacitor choice can reduce drastically these limitations.

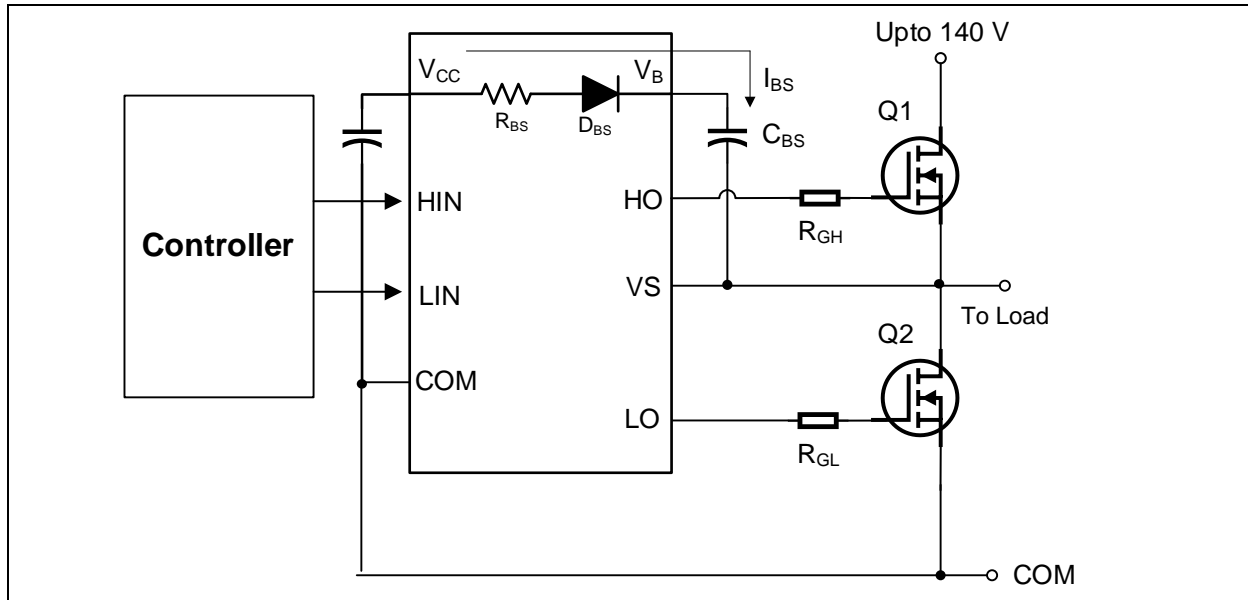

Figure 14 Half bridge bootstrap circuit in 2ED2772S01G

When the low side MOSFET turns on, it will force the potential of pin V_S to GND. The existing difference between the voltage of the bootstrap capacitor V_{CBS} and V_{CC} results in a charging current I_{BS} into the capacitor C_{BS} . The current I_{BS} is a pulse current and therefore the ESR of the capacitor C_{BS} must be very small in order to avoid losses in the capacitor that result in lower lifetime of the capacitor. This pin is on high potential again after low side is turned off and high side is conducting current. But now the bootstrap diode D_{BS} blocks a reverse current, so that the charges on the capacitor cannot flow back to the capacitor C_{VCC} . The bootstrap diode D_{BS} also takes over the blocking voltage between pin V_B and V_{CC} . The voltage of the bootstrap capacitor can now supply the high side gate drive sections. It is a general design rule for the location of bootstrap capacitors C_{BS} , that they must be placed as close as possible to the IC. Otherwise, parasitic resistors and inductances may lead to voltage spikes, which may trigger the undervoltage lockout threshold of the individual high side driver section. However, all parts of the 2ED2772S01G, which have the UVLO also contain a filter at each supply section in order to actively avoid such undesired UVLO triggers.

The current limiting resistor R_{BS} according to Figure 14 reduces the peak of the pulse current during the low side MOSFET turn-on. The pulse current will occur at each turn-on of the low side MOSFET, so that with increasing switching frequency, the capacitor C_{BS} is charged more frequently. Therefore, a smaller capacitor is suitable at higher switching frequencies. The bootstrap capacitor is mainly discharged by two effects: the high side quiescent current and gate charge of the high side MOSFET to be turned on.

The minimum size of the bootstrap capacitor is given by

$$C_{BS} = \frac{Q_{GTOT}}{\Delta V_{BS}}$$

ΔV_{BS} is the maximum allowable voltage drop at the bootstrap capacitor within a switching period, typically 1 V. It is recommended to keep the voltage drop below the undervoltage lockout (UVLO) of the high side and limit

$$\Delta V_{BS} \leq (V_{CC} - V_F - V_{GSmin} - V_{DSon})$$

$V_{GSmin} > V_{BSUV-}$, V_{GSmin} is the minimum gate source voltage we want to maintain and V_{BSUV-} is the high-side supply undervoltage negative threshold.

V_{CC} is the IC voltage supply, V_F is bootstrap diode forward voltage and V_{DSon} is drain-source voltage of low side MOSFET.

Please note, that the value Q_{GTOT} may vary to a maximum value based on different factors as explained below and the capacitor shows voltage dependent derating behavior of its capacitance.

The influencing factors contributing V_{BS} to decrease are:

- MOSFET turn on required Gate charge (Q_G)
- MOSFET gate-source leakage current (I_{LK_GS})
- Floating section quiescent current (I_{QBS})
- Floating section leakage current (I_{LK})
- Bootstrap diode leakage current (I_{LK_DIODE})
- Charge required by the internal level shifters (Q_{LS}): typical 1nC
- Bootstrap capacitor leakage current (I_{LK_CAP})
- High side on time (T_{HON})

Considering the above,

$$Q_{GTOT} = Q_G + Q_{LS} + (I_{QBS} + I_{LK_GS} + I_{LK} + I_{LK_DIODE} + I_{LK_CAP}) * T_{HON}$$

I_{LK_CAP} is only relevant when using an electrolytic capacitor and can be ignored if other types of capacitors are used. It is strongly recommend using at least one low ESR ceramic capacitor (paralleling electrolytic capacitor and low ESR ceramic capacitor may result in an efficient solution).

The above C_{BS} equation is valid for pulse by pulse considerations. It is easy to see, that higher capacitance values are needed, when operating continuously at small duty cycles of low side. The recommended bootstrap capacitance is therefore in the range up to 4.7 μF for most switching frequencies. The performance of the integrated bootstrap diode supports the requirement for small bootstrap capacitances.

6.10 Negative voltage transient tolerance of VS pin

A common problem in today's high-power switching converters is the transient response of the switch node's voltage as the power switches transition on and off quickly while carrying a large current. A typical 3-phase inverter circuit is shown in Figure 15, here we define the power switches and diodes of the inverter.

If the high-side switch (e.g., the MOSFET Q1 in Figures 16 and 17) switches from on to off, while the U phase current is flowing to an inductive load, a current commutation occurs from high-side switch (Q1) to the diode (D2) in parallel with the low-side switch of the same inverter leg. At the same instance, the voltage node V_{S1} , swings from the positive DC bus voltage to the negative DC bus voltage.

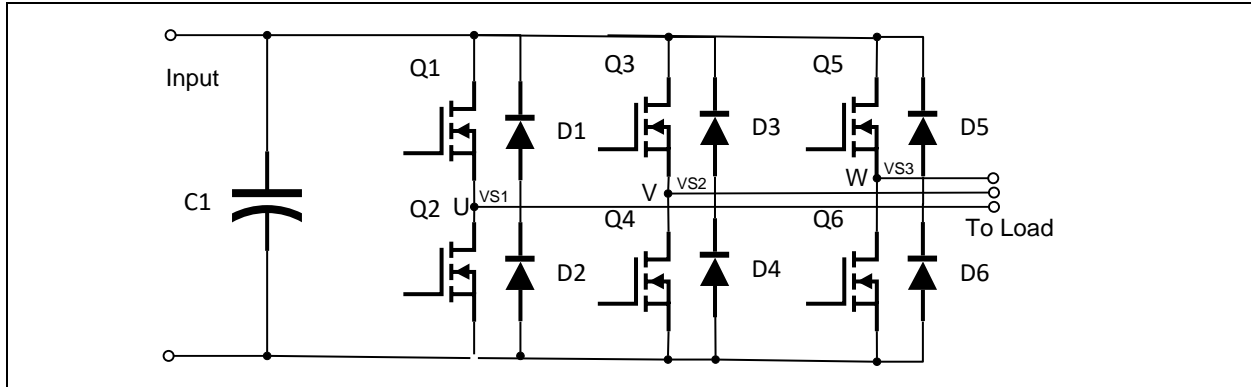

Figure 15 Half bridge inverter

Also when the V phase current flows from the inductive load back to the inverter (see Figures 16 C) and D)), and Q4 MOSFET switches on, the current commutation occurs from D3 to Q4. At the same instance, the voltage node, V_{S2} , swings from the positive DC bus voltage to the negative DC bus voltage.

However, in a real inverter circuit, the V_S voltage swing does not stop at the level of the negative DC bus, rather it swings below the level of the negative DC bus. This undershoot voltage is called “negative V_S transient”

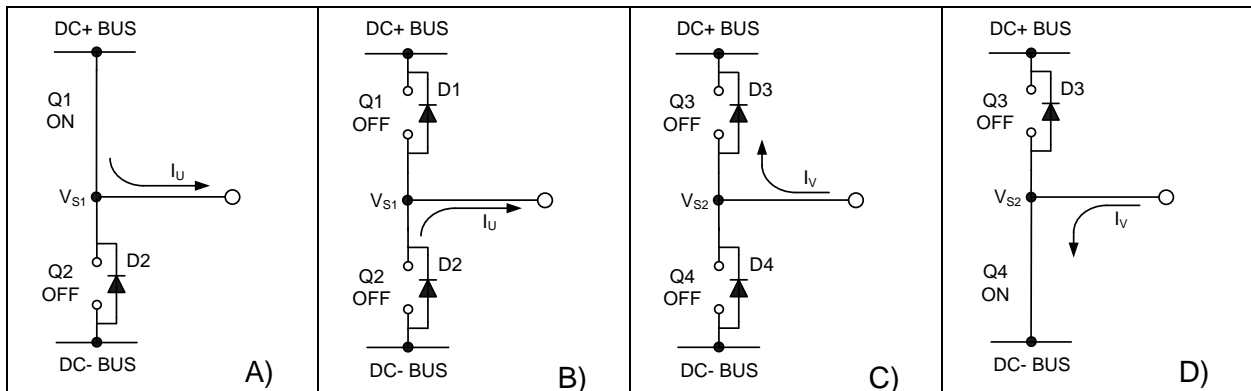

Figure 16 A) Q1 conducting B) D2 conducting C) D3 conducting D) Q4 conducting

The circuit shown in Figure 17-A depicts one leg of the half bridge inverter; Figures 17-B and 17-C show a simplified illustration of the commutation of the current between Q1 and D2. The parasitic inductances in the power circuit from the die bonding to the PCB tracks are lumped together in L_C and L_E for each MOSFET. When the high-side switch is on, V_{S1} is below the DC+ voltage by the voltage drops associated with the power switch and the parasitic elements of the circuit. When the high-side power switch turns off, the load current momentarily flows in the low-side freewheeling diode due to the inductive load connected to V_{S1} (the load is not shown in these figures). This current flows from the DC- bus (which is connected to the COM pin of the HVIC) to the load and a negative voltage between V_{S1} and the DC- Bus is induced (i.e., the COM pin of the HVIC is at a higher potential than the V_S pin).

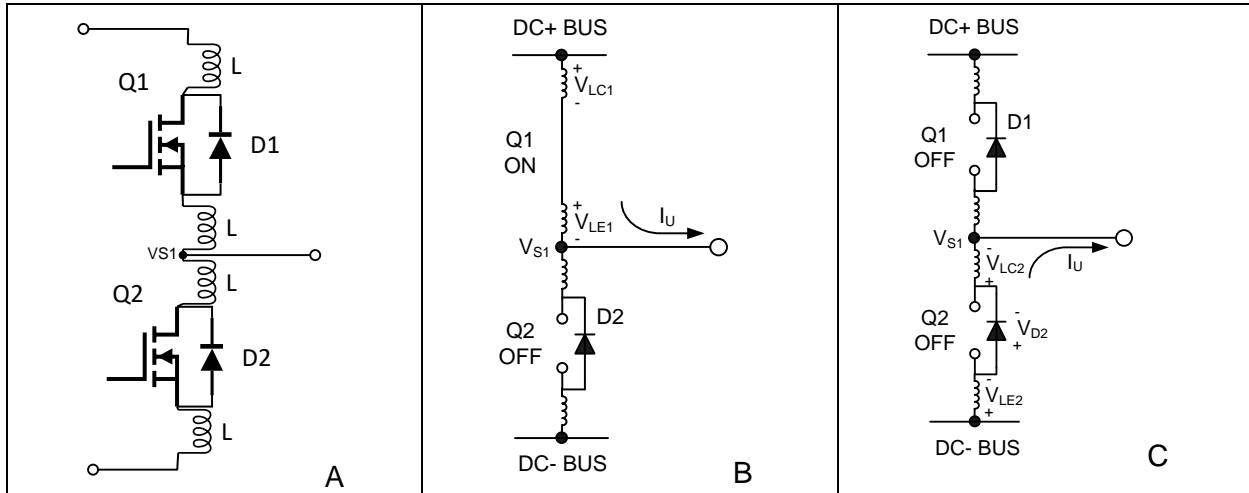

Figure 17 Figure A shows the Parasitic Elements. Figure B shows the generation of V_s positive. Figure C shows the generation of V_s negative

6.11 PCB layout tips

Distance between high and low voltage components: It's strongly recommended to place the components tied to the floating voltage pins (V_B and V_S) near the respective high voltage portions of the device. Please see the Case Outline information in this datasheet for the details.

Ground Plane: In order to minimize noise coupling, the ground plane should not be placed under or near the high voltage floating side.

Gate Drive Loops: Current loops behave like antennas and are able to receive and transmit EM noise (see Figure 18). In order to reduce the EM coupling and improve the power switch turn on/off performance, the gate drive loops must be reduced as much as possible. Moreover, current can be injected inside the gate drive loop via the MOSFET collector-to-gate parasitic capacitance. The parasitic auto-inductance of the gate loop contributes to developing a voltage across the gate-emitter, thus increasing the possibility of a self turn-on effect.

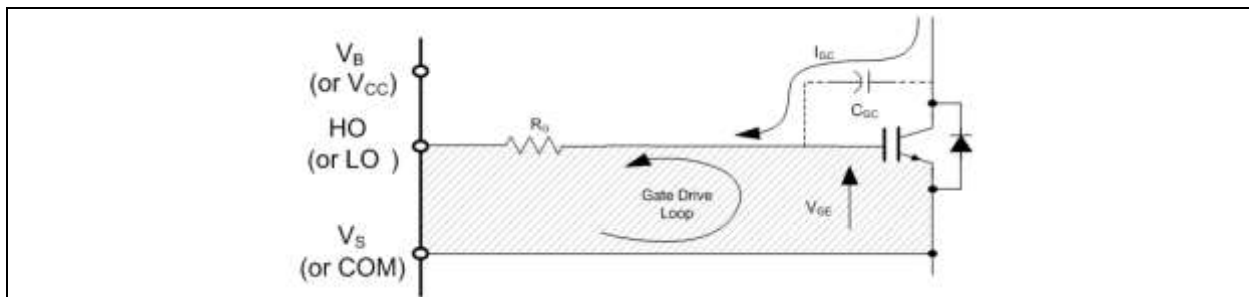

Figure 18 Avoid antenna loops

Supply Capacitor: It is recommended to place a bypass capacitor (C_{IN}) between the VCC and COM pins. A ceramic $1\mu\text{F}$ ceramic capacitor is suitable for most applications. This component should be placed as close as possible to the pins in order to reduce parasitic elements.

Routing and Placement: Power stage PCB parasitic elements can contribute to large negative voltage transients at the switch node; it is recommended to limit the phase voltage negative transients. In order to avoid such conditions, it is recommended to 1) minimize the high-side

emitter to low-side collector distance, and 2) minimize the low-side emitter to negative bus rail stray inductance. However, where negative V_S spikes remain excessive, further steps may be taken to reduce the spike. This includes placing a resistor ($5\ \Omega$ or less) between the V_S pin and the switch node (see Figure 19), and in some cases using a clamping diode between COM and V_S (see Figure 20).

See DT04-4 at www.infineon.com for more detailed explanations.

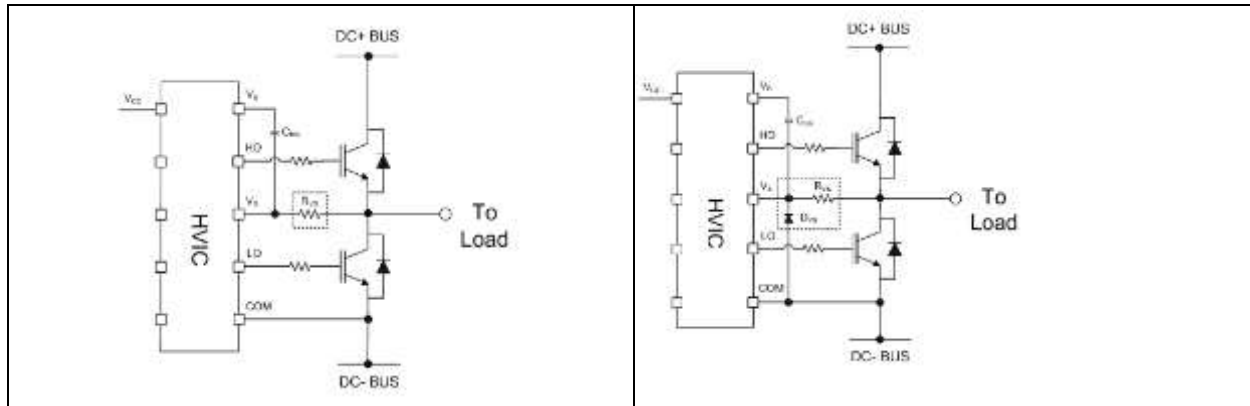

Figure 19 Resistor between the V_S pin and the switch node

Figure 20 Clamping diode between COM and V_S

7 Qualification information¹

Table 7 Qualification information

Qualification level		Industrial ²	
		Note: This family of ICs has passed JEDEC's Industrial qualification. Consumer qualification level is granted by extension of the higher Industrial level.	
Moisture sensitivity level		VSON-10	MSL2, 260 °C (per IPC/JEDEC J-STD-020)
ESD	Charged device model	Class C3 (1.0 kV) (per JEDEC standard JS-002_2018)	
	Human body model	Class 2a (2.5 kV) (per JEDEC standard JS-001_2017)	
IC latch-up test		Class II Level A (per JESD85)	
RoHS compliant		Yes	

8 Related products

Table 8

Product	Description
Gate Driver ICs	
6EDL04N02PR	200 V three-phase gate driver IC with integrated bootstrap diode, over current protection, enable and fault reporting
IRS200x	The IRS2005/7/8 200 V devices are offered in eight-pin DSO-8 or fourteen-pin 4 x 4 mm VQFN14 packages (IRS2005M) with various logic input options and standard pin-out configurations for high design flexibility and fast time to market. All devices are MSL2 qualified.
6EDL003L02-F2	EiceDRIVER™ Compact - Full bridge 3 Phase gate driver IC with LS-SOI technology to control power devices like MOS-transistors or 180V IGBTs
Power Switches	
OptiMOS™ 5	The new OptiMOS™ 5 150 V power MOSFETs from Infineon are particularly suitable for low voltage drives such as forklift and e-scooter, as well as telecom and solar applications
OptiMOS™ & StrongIRFET™	OptiMOS™ and StrongIRFET™ low- and medium voltage power MOSFETs enable innovation and performance in applications such as switch mode power supplies (SMPS), battery powered applications, motor control and drives, inverters, and computing
iMOTION™ Controllers	
IRMCK099	iMOTION™ Motor control IC for variable speed drives utilizing sensor-less Field Oriented Control (FOC) for Permanent Magnet Synchronous Motors (PMSM).
IMC101T	High performance Motor Control IC for variable speed drives based on field oriented control (FOC) of permanent magnet synchronous motors (PMSM).

¹ Qualification standards can be found at Infineon's web site www.infineon.com

² Higher qualification ratings may be available should the user have such requirements. Please contact your Infineon sales representative for further information.

9 Packaging information

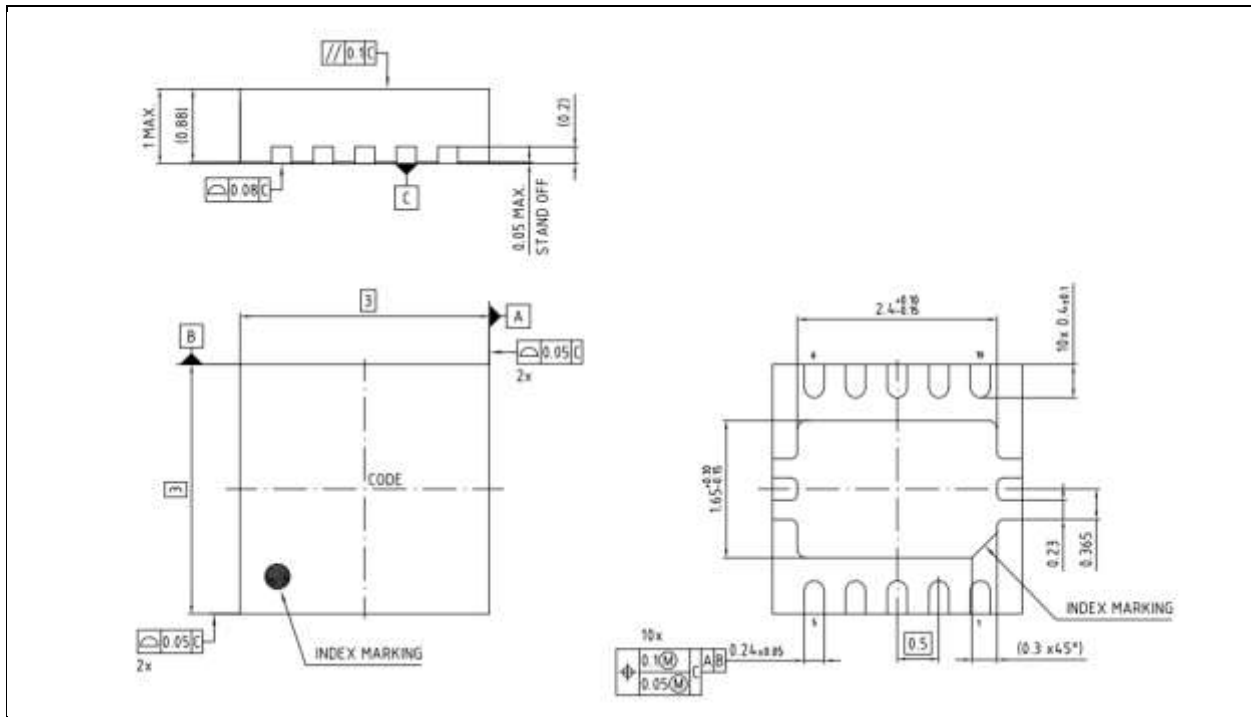

Figure 21 Target Package Dimensions: PG-VSON-10-5 (2ED2772S01G)

10 Additional documentation and resources

Several technical documents related to the use of HVICs are available at www.infineon.com; use the Site Search function and the document number to quickly locate them. Below is a short list of some of these documents.

Application Notes:

[Understanding HVIC Datasheet Specifications](#)

[HV Floating MOS-Gate Driver ICs](#)

[Use Gate Charge to Design the Gate Drive Circuit for Power MOSFETs and MOSFETs](#)

[Bootstrap Network Analysis: Focusing on the Integrated Bootstrap Functionality](#)

Design Tips:

[Using Monolithic High Voltage Gate Drivers](#)

[Alleviating High Side Latch on Problem at Power Up](#)

[Keeping the Bootstrap Capacitor Charged in Buck Converters](#)

[Managing Transients in Control IC Driven Power Stages](#)

[Simple High Side Drive Provides Fast Switching and Continuous On-Time](#)

10.1 Infineon online forum resources

The Gate Driver Community is live at Infineon Community (<https://community.infineon.com/t5/Gate-Driver-ICs/bd-p/GateDriverICs>). This online forum is where the Infineon gate driver IC community comes to the assistance of our customers to provide technical guidance – how to use gate drivers ICs, existing and new gate driver information, application information, availability of demo boards, online training materials for over 500 gate driver ICs. The Gate Driver community also serves as a repository of FAQs where the user can review solutions to common or specific issues faced in similar applications.

Register online at <https://community.infineon.com/> and learn the nuances of efficiently driving a power switch in any given power electronic application.

11 Revision history

Document version	Date of release	Description of changes
1.0	August 01 2023	Final Datasheet

Trademarks

All referenced product or service names and trademarks are the property of their respective owners.

Edition 2023-06-01

Published by

Infineon Technologies AG

81726 Munich, Germany

© 2023 Infineon Technologies AG.

All Rights Reserved.

Do you have a question about this document?

Email: erratum@infineon.com

Document reference

IMPORTANT NOTICE

The information given in this document shall in no event be regarded as a guarantee of conditions or characteristics ("Beschaffheitsgarantie").

With respect to any examples, hints or any typical values stated herein and/or any information regarding the application of the product, Infineon Technologies hereby disclaims any and all warranties and liabilities of any kind, including without limitation warranties of non-infringement of intellectual property rights of any third party.

In addition, any information given in this document is subject to customer's compliance with its obligations stated in this document and any applicable legal requirements, norms and standards concerning customer's products and any use of the product of Infineon Technologies in customer's applications.

The data contained in this document is exclusively intended for technically trained staff. It is the responsibility of customer's technical departments to evaluate the suitability of the product for the intended application and the completeness of the product information given in this document with respect to such application.

For further information on the product, technology delivery terms and conditions and prices please contact your nearest Infineon Technologies office (www.infineon.com).

WARNINGS

Due to technical requirements products may contain dangerous substances. For information on the types in question please contact your nearest Infineon Technologies office.

Except as otherwise explicitly approved by Infineon Technologies in a written document signed by authorized representatives of Infineon Technologies, Infineon Technologies' products may not be used in any applications where a failure of the product or any consequences of the use thereof reasonably be expected to result in personal injury.