

## Product Brief

# 24GHz radar sensor – family extension with twin transmitter & quad receiver for automotive applications

The BGT24Axx family is the highest integrated and broadest portfolio of 24GHz band radar transceiver family currently in the market. It saves ~30 percent board space compared to discrete line ups. Infineon offers in total 5 different components. This document describes 2 new MMICs, the BGT24AT2 which combines two transmit channel and the BGT24AR4, a MMIC with four receive channels. Combinable with both chipsets to increase number of transmitter and receiver channels for more advanced radar functions.

The 24GHz radar is able to detect the movement and speed of any object in a confined space, thus widely used in security and anti-theft systems in factories, warehouses and private residences. In addition, the 24GHz automotive radar solution for ADAS (Advanced Driver Assistance Systems) may ensure driving safety by perfectly combining the automotive microcontroller (AURIX™ family) and the radar sensor for measurement and calculation of distance between an obstacle and a vehicle, as well as a smart secure power chip that guarantees system stability.

In a car environment, energy efficiency becomes more and more important. At the same time, certain automotive quality regulations like AEC-Q100 have to be observed. Thanks to Infineon's new 24GHz radar product family BGT24Axx, these needs can now be addressed.

The high integration of the Infineon solution – with either two transmit channels or four receive channels – saves expensive PCB space and makes the design easy. The standard (V)QFN package can be mounted in available SMT (Surface Mounted Technology) production lines at customers.

### Applications for Mid-Range-Radar (MRR) to Short-Range-Radar (SRR)

- > Blind Spot Detection (BSD)
- > RCTA (Rear Cross Traffic Allert)
- > Lane Change Assistance (LCA)
- > Collision Mitigation (CM)
- > Parking Aid (PA)
- > TSR (Traffic Sign Recognition)

### Key features

- > AEC-Q100 qualified
- > Ambient temperature range: -40°C ~ +125°C
- > Fully integrated twin transmitter and quad receiver solution on-chip
- > Fully integrated low phase noise VCO
- > Low noise figure
- > Switchable prescaler
- > On chip power and temperature sensors
- > Single supply voltage 3.3 V
- > Low power consumption at AT2-775 mW, at AR4-610 mW
- > VQFN-32-9 leadless plastic package including Lead-Tip-Inspection (LTI) feature
- > Pb-free (RoHS compliant) package

# 24GHz radar sensor – family extension with twin transmitter & quad receiver for automotive applications

## BGT24AR4

### Quad receiver MMIC

- > AEC-Q100 qualified
- > Featuring IF filters and programmable gain base band amplifiers
- > On chip LO level and temperature sensors
- > Disable mode for downconverter and base band amplifiers via SPI
- > Single ended RF terminals
- > Power and temperature sensors
- > Power consumption of 610 mW
- > Compact leadless VQFN-32 package including Lead-Tip-Inspection (LTI) feature

## BGT24AT2

### Twin transmitter MMIC

- > AEC-Q100 qualified
- > Featuring Programmable Gain Amplifiers (PGA) with 6-bit resolution
- > Fully integrated low phase noise VCO
- > On chip RF output level and temperature sensors
- > Single ended RF terminals
- > Power and temperature sensors
- > Power consumption of 775 mW
- > Compact leadless VQFN-32 package including Lead-Tip-Inspection (LTI) feature

Block diagram BGT24AR4

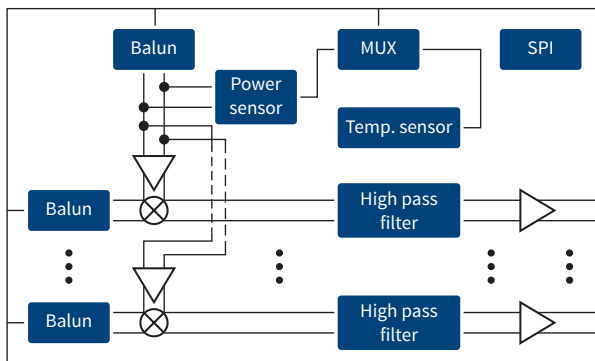

Block diagram BGT24AT2

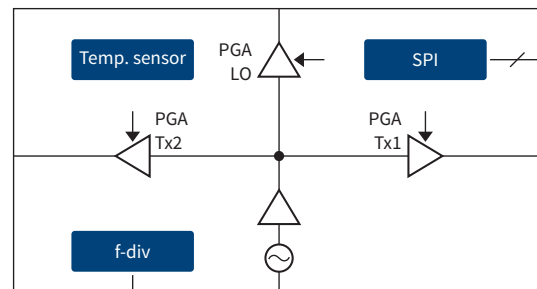

### Why Infineon's 24GHz solutions?

- > High integration and SMT package of multiple transmitter or receiver on-chip
  - Less PCB space required
- > Just matching structures required
- > Industry standard QFN-style package for mounting in standard SMT production lines
  - Existing customer production equipment, no special technologies are required

- > High volume in house production of advanced SiGe technology
  - Leading market player
- > Complete radar portfolio for 24 GHz
  - RF MMIC and microcontroller
  - Serving and supporting future ADAS requirements

### Orderable part No.

- > BGT24AT2
- > BGT24AR4

Published by  
Infineon Technologies AG  
85579 Neuburg, Germany

© 2016 Infineon Technologies AG.  
All Rights Reserved.

### Please note!

THIS DOCUMENT IS FOR INFORMATION PURPOSES ONLY AND ANY INFORMATION GIVEN HEREIN SHALL IN NO EVENT BE REGARDED AS A WARRANTY, GUARANTEE OR DESCRIPTION OF ANY FUNCTIONALITY, CONDITIONS AND/OR QUALITY OF OUR PRODUCTS OR ANY SUITABILITY FOR A PARTICULAR PURPOSE. WITH REGARD TO THE TECHNICAL SPECIFICATIONS OF OUR PRODUCTS, WE KINDLY ASK YOU TO REFER TO THE RELEVANT PRODUCT DATA SHEETS PROVIDED BY US. OUR CUSTOMERS AND THEIR TECHNICAL DEPARTMENTS ARE REQUIRED TO EVALUATE THE SUITABILITY OF OUR PRODUCTS FOR THE INTENDED APPLICATION.

WE RESERVE THE RIGHT TO CHANGE THIS DOCUMENT AND/OR THE INFORMATION GIVEN HEREIN AT ANY TIME.

### Additional information

For further information on technologies, our products, the application of our products, delivery terms and conditions and/or prices, please contact your nearest Infineon Technologies office ([www.infineon.com](http://www.infineon.com)).

### Warnings

Due to technical requirements, our products may contain dangerous substances. For information on the types in question, please contact your nearest Infineon Technologies office.

Except as otherwise explicitly approved by us in a written document signed by authorized representatives of Infineon Technologies, our products may not be used in any life-endangering applications, including but not limited to medical, nuclear, military, life-critical or any other applications where a failure of the product or any consequences of the use thereof can result in personal injury.