

New 1200V Integrated Circuit Changes The Way 3-Phase Motor Drive Inverters Are Designed

David Tam

International Rectifier, El Segundo, California

New 1200-V high voltage integrated circuit technology and design advances enable a whole new class of 3-phase motor drive inverters that set new benchmarks for efficiency, compactness and ruggedness. The new IC, IR2233, reduces gate drive component counts by 88%, PCB space by 66% and production cost by 33% as compared to discrete circuits for a 460VAC 3-HP inverter.

Variable frequency drive (VFD) is an essential element of energy saving, variable speed inverter drives for AC induction, AC synchronous, brushless DC and AC motors. To a large extent, power conversion components determine the efficiency, size, ruggedness and manufacturing cost of the VFD inverter. The critical power building blocks for the VFD solution include:

- High voltage power semiconductors (three-phase input rectifier and three-phase IGBT inverter stage)
- Gate drive circuits
- System power supply
- Current, voltage and temperature sensing elements with associated protection circuits
- DC bus capacitor
- Surge suppression
- Mechanical interface

Typical construction of the inverter drive would partition the power semiconductors with the current and temperature sensing elements in one power assembly or module connected to a p.c. board populated with gate drive, protection, system power supply, interface and other control circuits. Figure 1 is a block diagram of a typical power stage for a three-phase inverter. The achievable power rating of the inverter is governed not just by the IGBT devices but also by the coupling of the gate drive circuit. Ruggedness of the inverter stage is largely a function of the protection strategy and associated circuits. With advanced packaging techniques for the power assembly, the size of the inverter is

often determined by the size of the control, protection and driver p.c. boards. Older generation gate drive circuits typically used optocouplers with a number of discrete devices that tend to result in high component count and a large amount of board space. The new generation of efficient, rugged and compact inverters look to higher

levels of integration for the gate drive and protection circuits along with efficient coupling to the power stage. The solution lies in configuring highly integrated gate drive circuits into a single monolithic IC, except for the added complication of the need to process high voltage signals along side low voltage circuits inside the same IC chip.

1200V HVIC Technology

A monolithic high voltage integrated circuit (HVIC) technology is required to integrate all the circuits that drive and protect high voltage MOSFETs or IGBTs in

a high side or bridge topology. A 600V rating is required for inverter designs operating from 200-230VAC and a 1200V rating is required for 460VAC. Such an HVIC technology requires integration of

analog control circuits and high voltage level shifting devices together with the capability of the analog circuits operating from a floating supply rail that can move around from below ground to above the high voltage DC bus.

The new 1200V HVIC technology is based on the same device structure of the well established 600V version. A number of devices are available in this mixed technology process using n-epitaxial layer on p-substrate structure as shown in Figure 2. High voltage lateral DMOS (LDMOS), both n-channel and p-channel types, have high breakdown voltages and low input capacitances. They are ideal devices for level shifting circuits. CMOS and bipolar devices are used for control circuits. The primary application for the technology is for power control circuits, therefore the CMOS and bipolar devices are rated to operate from up to 20V, which is the typical requirement for the maximum gate drive voltage of power MOSFET or IGBT. Circuit integration is accomplished through a combination of junction isolation for the LDMOS, bipolar and CMOS device epitaxial islands and self-isolation between CMOS devices for high density integration.

The high breakdown voltages of the LDMOS devices are achieved through the use of lateral charge control in the drain region. Additional structural and doping tricks are used to shape and reduce the surface E-field to move the breakdown point into the bulk between the n-epitaxial and p-substrate junction. Hence the technique allows the use of thin epitaxial layer for very high voltage breakdown to above 1200V. The thin epitaxial layer in turn allows low cost integration of bipolar and CMOS devices on the same chip with high voltage devices.

Individual epitaxial islands can also be isolated with high voltage termination so that CMOS circuits built inside the epitaxial island can float up to the breakdown voltage with respect to the substrate potential that is typically biased at the ground potential. This feature allows the integration of CMOS gate drive circuit to drive a n-channel high side

switch with a floating reference to the source terminal, which is the topology required for the power stage of a three-phase inverter.

The arrangement of the logic and analog control, low side gate drive, high side gate drive and level shifting circuits in the same junction isolated HVIC chip requires understanding of the biasing and transient conditions to ensure proper operation. The various parasitic diodes inside the chip are shown in Figure 3. The substrate diode must not be allowed to turn on or latch-up would occur. Also the individual breakdown voltages of the various high voltage and low voltage diodes must not be exceeded otherwise avalanche induced CMOS latch-up would also occur.

1200V Three-Phase Gate Drive IC

A new architecture for the gate drive circuits of a 460VAC three-phase inverter is created by using the 1200V HVIC technology. The first product is the IR2233 that provides in a single chip all the circuits necessary to interface between the microcontroller and the three-phase IGBT power stage. The block diagram and the application circuit for the IR2233 driving a three-phase IGBT inverter stage is shown in Figure 4. A functional and pin compatible 600V version, IR2133, is also available for 200-230VAC three-phase inverter designs. The die plots for the 1200V IR2233 and 600V IR2133 are shown in Figure 5.

Major functional blocks in the IR2233 include:

- Three high side floating gate drives and associated level shifting circuits from ground to floating references
- Three low side gate drives and associated level shifting circuits from logic ground to power ground reference
- Current sensing amplifier
- Overcurrent trip comparator

- Timing, sequencing, fault and protection logic
- Interface and filtering circuits to analog and digital inputs

The high-side gate drive functional block includes push-pull CMOS drivers designed to drive IGBT, undervoltage lockout, dv/dt filter and level shifting. The common mode capability is up to 1200V (as measured from VB1, VB2 or VB3 to COM pin) and that means that the entire gate drive circuit is referenced to a floating node (VS1, VS2 or VS3 pin) that can move below ground to a high voltage potential not exceeding 1200V. In the application circuit the high side gate drive is referenced to the emitter node of the high side IGBT, which is also the output of the bridge circuit. The floating supply ($VBS=VB-VS$) is derived from a bootstrap diode and capacitor (Figure 4). The allowable swing below ground is up to the floating bias voltage (typically 15-20V) beyond that the internal substrate diode would turn on causing a latch-up condition as shown in Figure 3. Note that the level shifting circuit is designed to shift information from ground level to the floating circuit, one limitation is that the circuit would not change state when VS is more than 5V below ground. That means that the high side circuit cannot be commanded on when the output of the bridge is in the lower diode recovery transient state.

Special care has been taken to design-in immunity from the full spectrum of transients at the IGBT emitter node. Typical dv/dt rate for three-phase IGBT inverter stage can range from 1V/nsec up to 50V/nsec. The internal dv/dt filter circuit rejects false turn-on or turn-off pulses induced by dv/dt transients. Additional application precautions have to be taken to insure that the fast dv/dt transients would not cause a failure of the IGBT or freewheeling diode even though the IR2233 is operating correctly.

In the bootstrap configuration, the charge in the floating capacitor can be depleted if not refreshed periodically, which can occur if the high side IGBT is left on for a long period. The undervoltage lockout circuit, UVBS, would turn off the gate drive if VBS is below 8.3V. This protects the IGBT from going into a high dissipation mode.

Another application consideration is the overcharging of the bootstrap capacitor, which can occur if the high side IGBT emitter node swings substantially below ground, the charging impedance is low and the value of the bootstrap capacitor is small. In this condition, overcharging can occur so that the voltage, VBS, appearing across the gate drive circuit can exceed 25V, causing a potential CMOS avalanche induced latch-up condition. The solution is to minimize stray inductance in the IGBT emitter current path, and choose the right value of bootstrap capacitor and charging impedance.

Both the high-side and low-side differential mode gate drive voltages (HO and LO) can be as high as 20V. The gate drive sourcing current capability is 250mA and the sinking current capability is 500mA. Crossover distortion is minimized to allow efficient transfer of gate charge with minimum EMI. The gate drive stage is capable of driving effectively up to a size 5 IGBT. Figure 6 shows the gate drive waveform driving the 1200V IRGPH50KD2 CoPack IGBT for the inverter stage of a 3HP motor. A critical design parameter in the gate drive stage is the latch-up immunity from reverse current due to displacement current feedback from the IGBT output stage. The CMOS output stage is designed with latch-up immune device structures and layout techniques to allow reverse current substantially exceeding 500mA without causing latch-up. External Schottky clamp diodes are not required for protection.

The grounding system inside the IC is designed to provide high noise immunity. The substrate of the chip is tied to the power ground potential or the COM pin. Each high side gate drive has its own floating reference and associated level shifting circuit from COM to VBS . The three low side gate drives are referenced to the COM pin. Level shifting from logic ground (VSS) to power ground (COM) is used to achieve high noise immunity for the logic circuit. The separate VSS and COM pins also provide convenient connection points for a current sensing resistor.

The current sense amplifier amplifies phase leg current from a low-value precision sensing resistor in the power return path. The two inputs (CA+, CA-) and the output (CAO) of the amplifier are available as external pins to simplify noise filtering. All three pins have 5.5V clamp diodes to limit the voltage excursion. The current sense amplifier has a 15V/ μ sec slew rate and less than 10mV offset.

The input (HIN and LIN) to output (HO and LO) logic is active low, which means that the output is out of phase with the input. Protection logic includes:

- Simultaneous conduction prevention (HO and LO for the same channel cannot be on at the same time)
- Logic level shutdown (SD)
- Analog level shutdown (ITRIP)
- Under-voltage shutdown (UVBS and UVCC)
- Fault reporting (FAULT)
- Fault clearing (FLT-CLR).

Figure 7 shows the logic timing diagram. The logic level shutdown is used to interface with the system controller and the analog level shutdown is used to interface with local overcurrent or over-temperature sensing amplifier output. The FAULT pin is an open-drain output that turns on whenever fault conditions occur from SD, ITRIP and

UVCC. The chip will stay off until the FLT-CLR pin is pulled low to clear the fault mode. All the logic pins have 5.5V clamp diode together with pull-up or pull-down resistor (Figure 8) that allow the chip to interface with optocouplers, open-collector or 5V CMOS output devices.

The dead-time circuit is internally set to 200nsec dead-time, which allows the system controller to have a high level of control flexibility. All the logic input pins (HIN and LIN) have a 300nsec filtering time and the shutdown pins (SD, ITRIP) have 400nsec blanking time. This allows the chip to operate in noisy environments.

The monolithic chip is assembled in a customized 44-pin PLCC package. High voltage and low voltage pins are separated with missing pins taken out from the package to increase voltage creepage distance.

POWIRTRAIN Integrated Power Stage

The IR2233 had been successfully implemented in an integrated power stage (called the POWIRTRAIN IRPT2051) for a 460VAC, 3-HP motor (Figure 9). The 1200V rated power module includes three-phase rectifier, brake IGBT and freewheeling diode, three-phase IGBT inverter stage, high and low rails 25m Ω low inductance current shunts and positive temperature coefficient thermistor (PTC). All the power components are housed inside a compact epoxy encapsulated case with an injection molded shell and leadframe casing. The bottom plate, composed of the back of an insulated metal substrate (IMS), provides mating surface with a heat sink. The driver board operates with the power module and it contains the IR2233 gate drive circuit, protection circuit, feedback signals, brake function and local power supply.

Compared to a discrete implementation of the gate drive circuit, the IR2233 solution cuts component counts from 172 to 20 and

PCB space from 80cm² to 27cm² (Figure 10). The total production cost of the gate drive circuit is reduced from \$14.1 to \$9.6. Besides the advantages in added functionality, compactness, ruggedness and cost, the IR2233 solution contributes to higher level of quality with lower rework rates and lower inventory management cost.

Designing the power module together with the driver board focuses the problems of achieving higher system level performance instead of individual component performances. The resulting integrated

power stage has higher level of efficiency, ruggedness and power density together with lower manufacturing cost. Figure 11 shows the performance curve of the 3HP system. Additional benefits of designing the integrated power stage and testing them as a complete inverter system in the motor drive environment include getting the maximum performance out of the IR2233, optimization of layout for the gate drive circuit, improvement in noise immunity and thorough analysis and counter-measures for possible failure mechanisms.

Other gate driver ICs are available for inverter design targeted for different applications. The following table summarize the current product family for motor drive inverter :

Product Family	Maximum Voltage	Topology	Targeted Applications
IR2233 (New)	1200V	3-Phase	Industrial Motor Drives for 460 VAC to 5 HP with integrated protection and compact design
IR2130, IR2132 IR2131 IR2133 (New)	600V	3-Phase	Industrial Motor Drives for 230 VAC to 5 HP with integrated protection and compact design
IR2110, IR2113	600V	½ Bridge	High performance and high power inverters using large size IGBT or FET switch
IR2101, IR2102, IR2103, IR2104, IR2111, IR2112	600V	½ Bridge	Cost sensitive inverter designs for appliance and HVAC
IR2125 IR2127 (New) IR2128 (New)	600V	High Side	Inverter Designs requiring over-current protection for each IGBT or FET switch and high side error reporting

Other POWIRTRAIN integrated power stages are available for inverter designs for different applications. The current product family includes :

Part Number	3-Phase Input	Rated Output	IGBT Type	Gate Drive	Power Assembly
IRPT1053 IRPT1056	200-230 VAC	1-HP	Gen3 Size3 600V	IR2132	Chip & Wire on IMS
IRPT2056	200-230 VAC	3-HP	Gen4 Size4 600V	IR2133	Chip & Wire on IMS
IRPT2051	460VAC	3-HP	Gen3 Size4 1200V	IR2233	Chip & Wire on IMS
IRPT5051	380-480 VAC	15-HP	Gen3 Size7 1200V	Discrete	SMD-10 Surface Mount

Figure 1 : Block Diagram of Inverter Power Stage

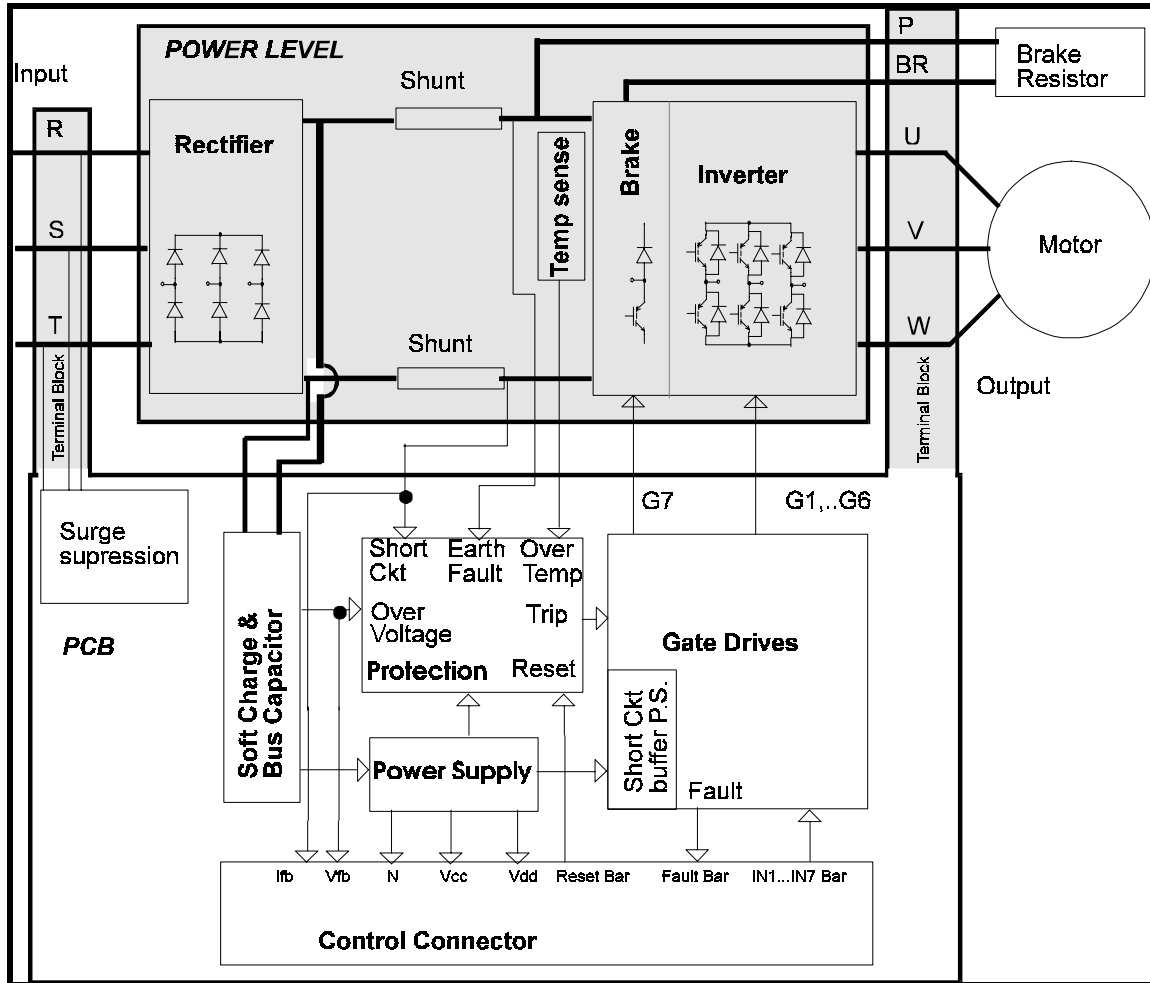

Figure 2 : Device Cross Section of the High Voltage Integrated Circuit

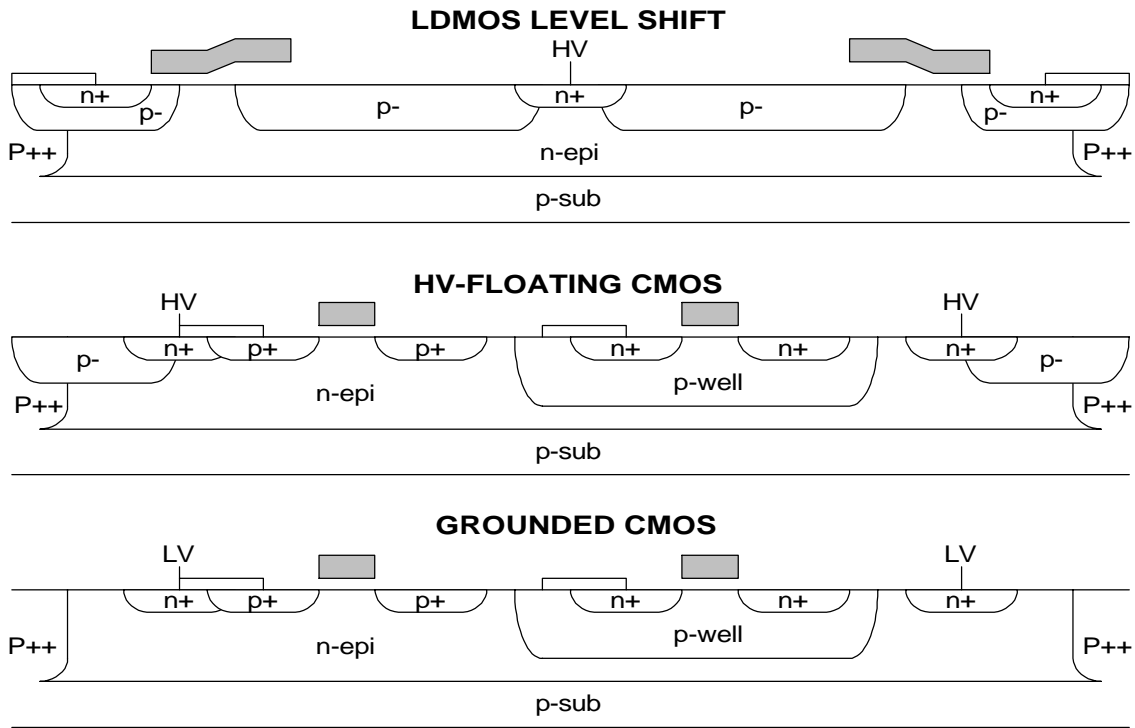

Figure 3 : Parasitic Diode Structures of the HVIC Chip

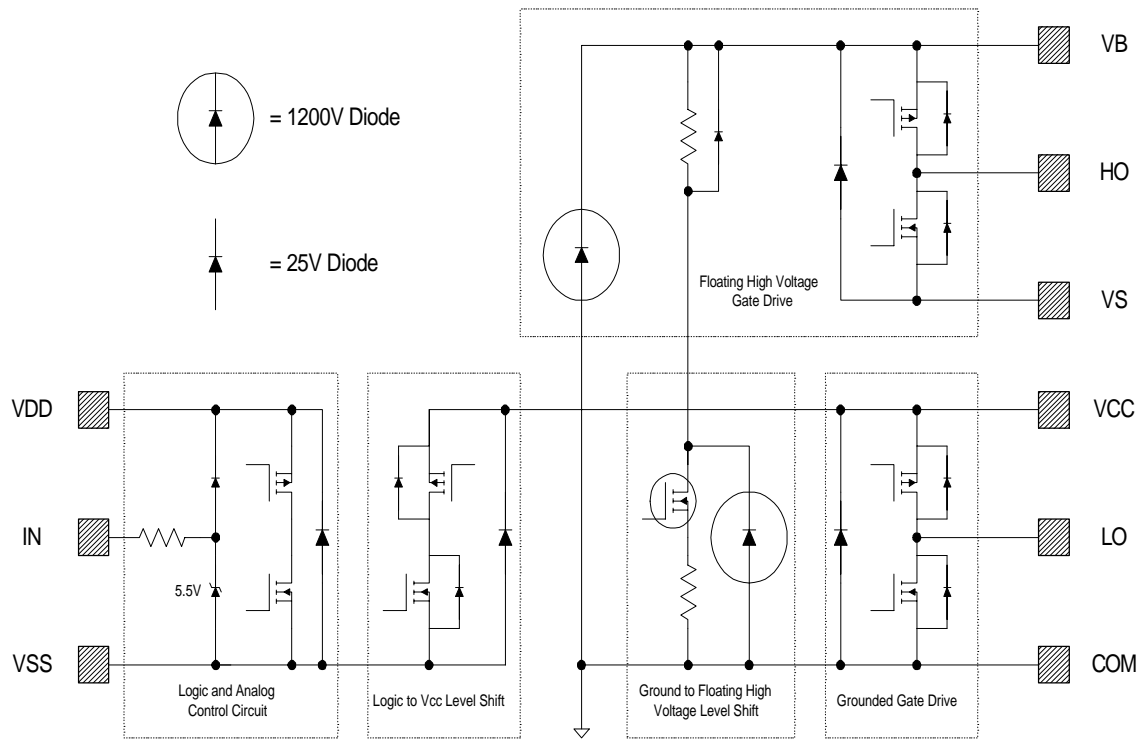

Figure 4a : IR2233 Block Diagram

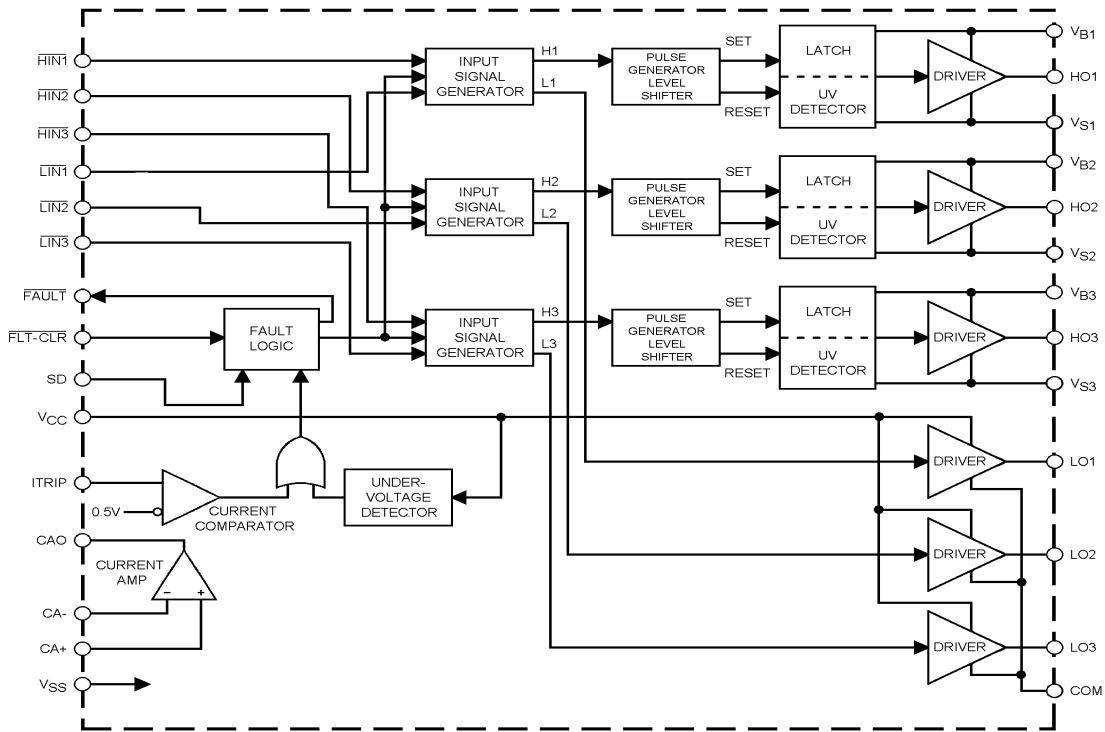

Figure 4b : IR2233 Application Circuit Driving a 3-Phase IGBT Power Stage

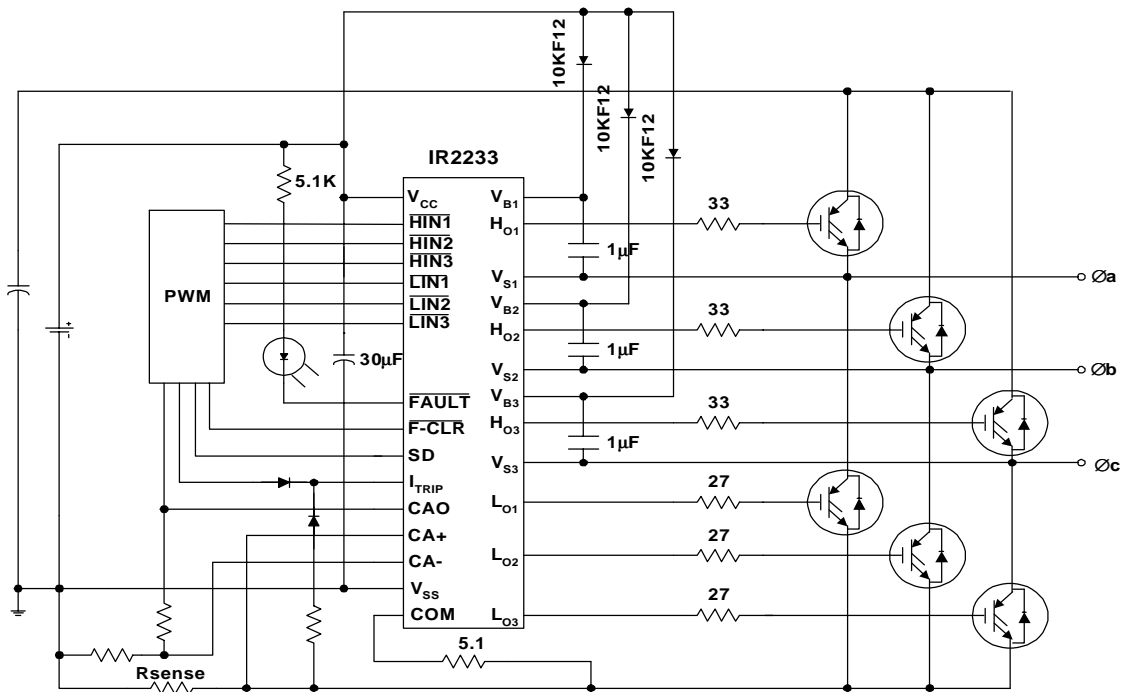

Figure 5a : Die plot of the 1200V IR2233

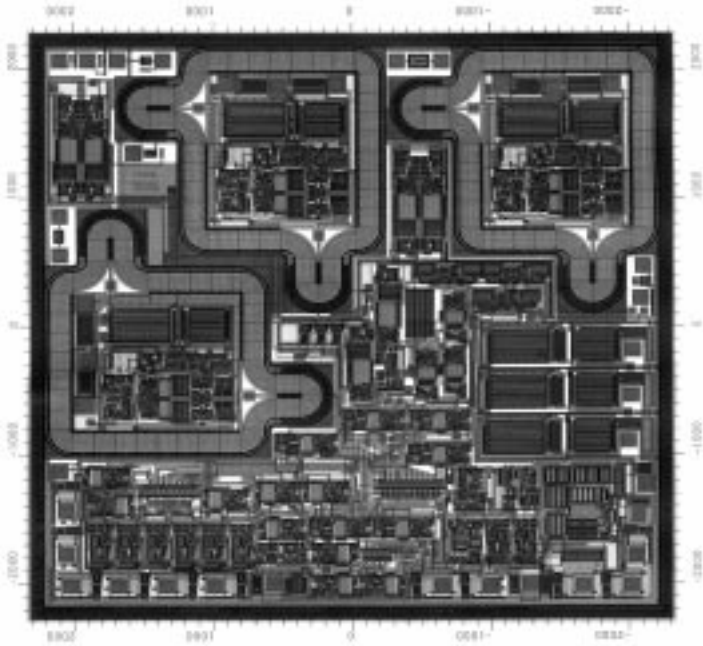

Figure 5b : Die plot of the 600V IR2133

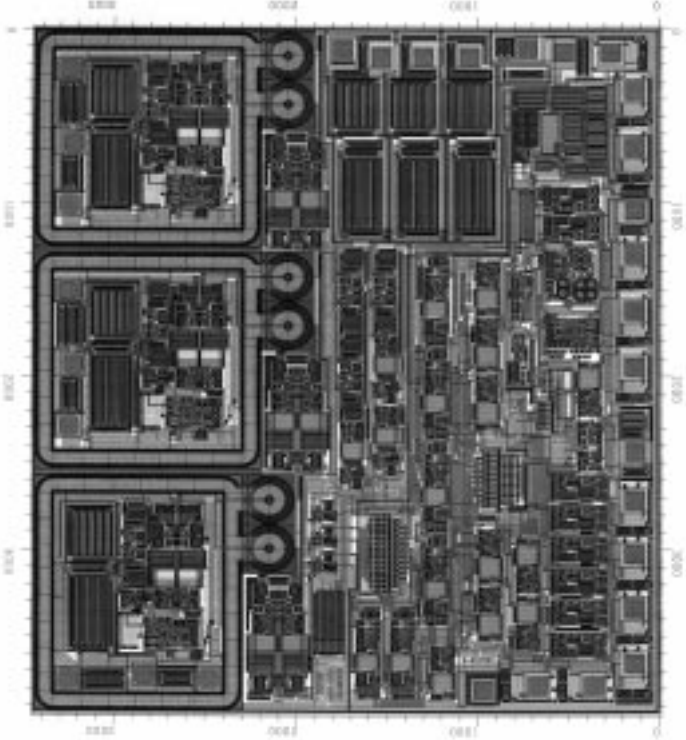

Figure 6 : Gate Drive Waveform of IR2233 Driving IRGPH50KD2 CoPack IGBT

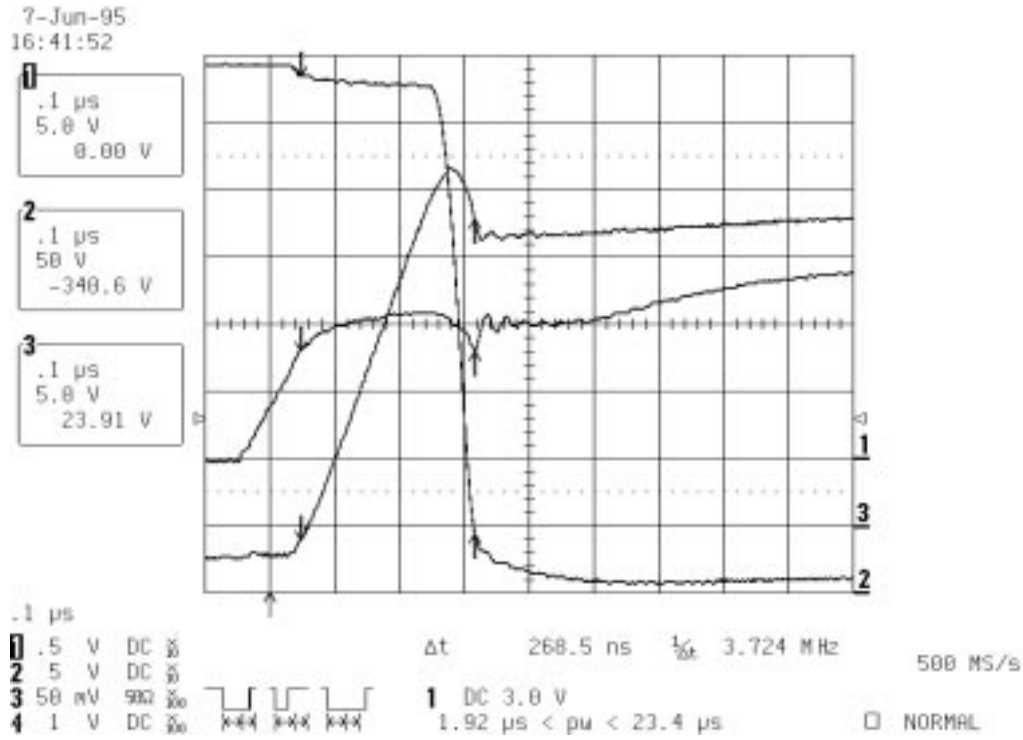

Figure 7 : IR2233 Timing Diagram

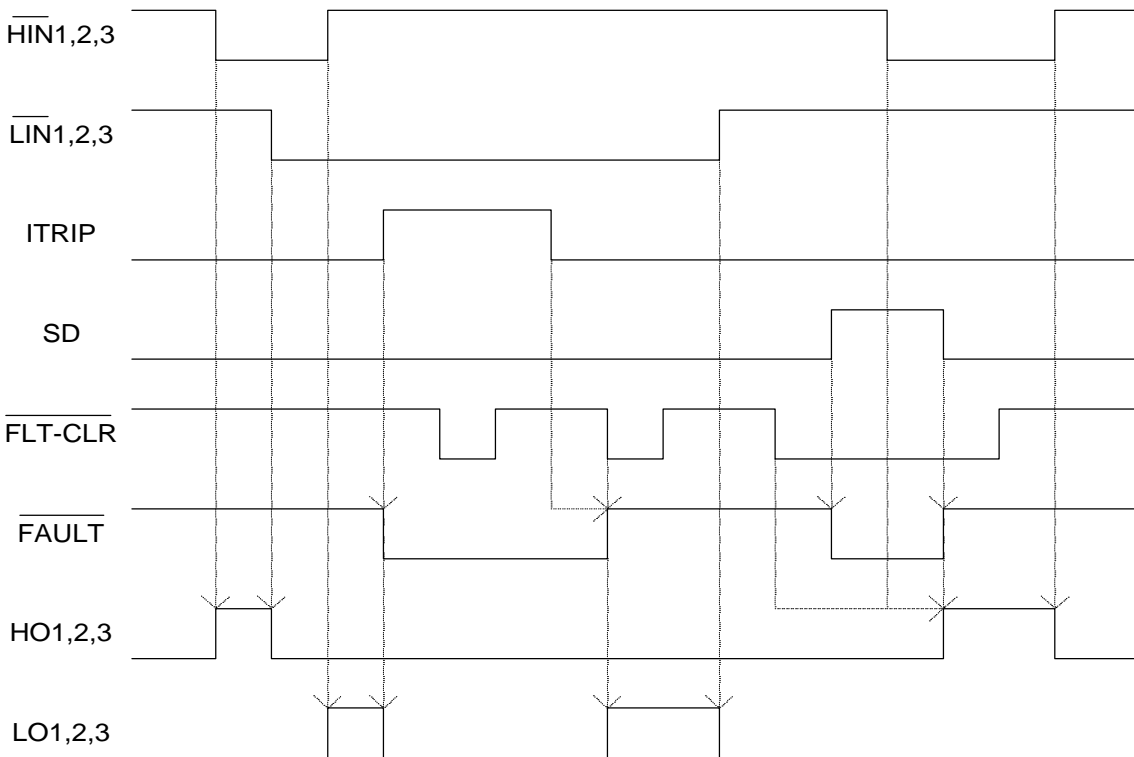

Figure 8 : Diode Clamp Circuits for IR2233 Input and Output Pins

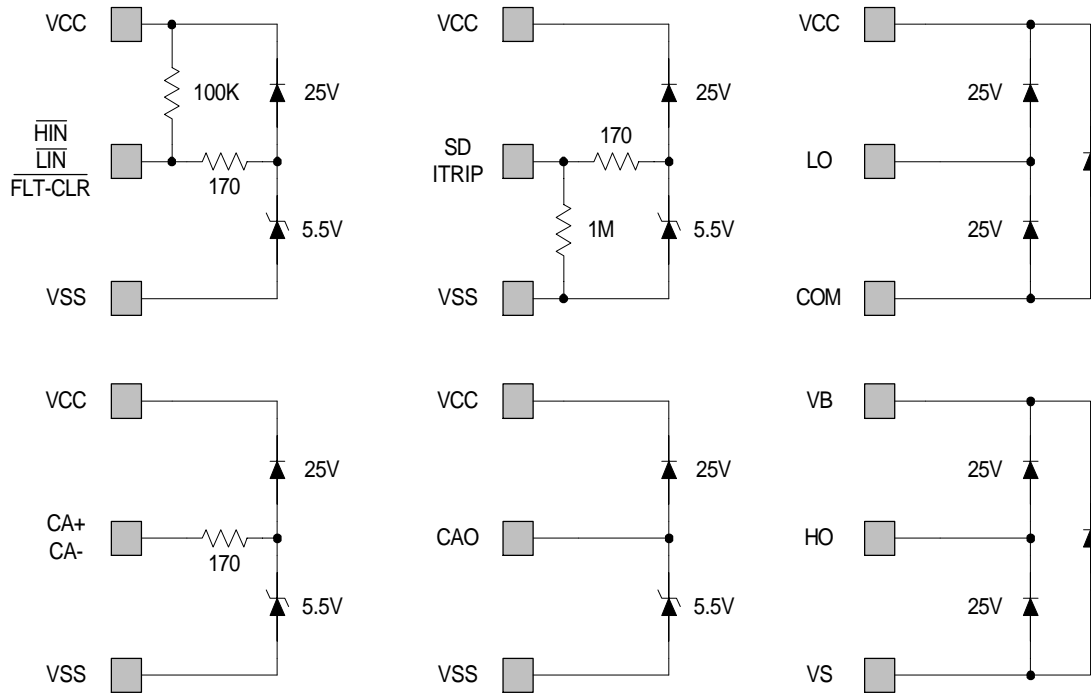

Figure 9 : 460VAC, 3HP Integrated Power Stage (IRPT2051)

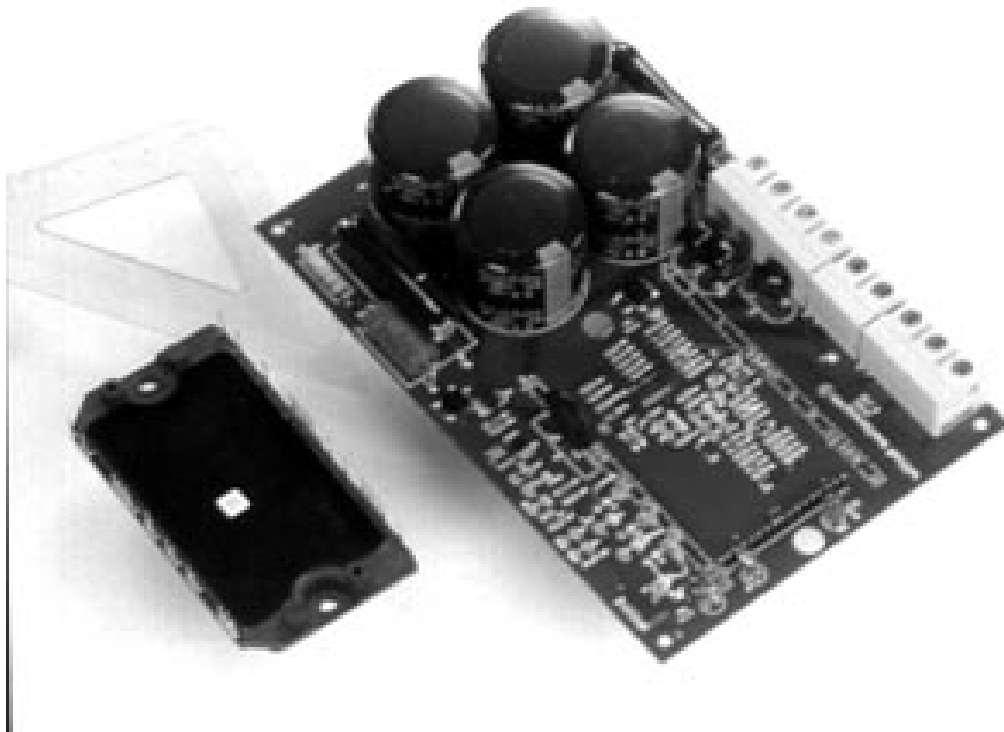

Figure 10 : Gate Drive Circuit Comparison : Discrete vs. IR2233 Solution

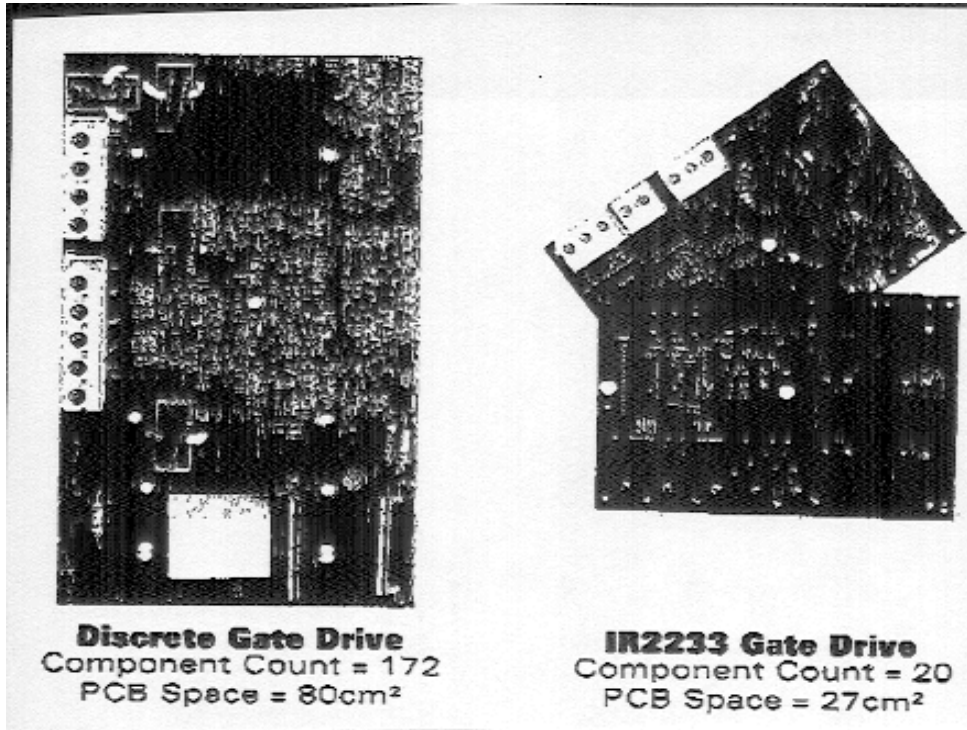

Figure 11 : Performance Curve for 3HP POWIRTRAIN Using IR2233 Gate Driver

