



The New MiniPROFET™ Family – Protected High-Side Switches for Industrial Applications

The new Industrial MiniPROFET™ family is a family of protected single channel Smart High-Side NMOS-Power Switches with charge pump and CMOS compatible input. The devices are monolithically integrated in Smart technology.

Applications

- Microcontroller-compatible power switch for 12V/24V and 42V DC applications
- High-speed PWM applications
- Qualified for 12V and 24V applications
- All types of resistive, inductive and capacitive loads
- Replacement of electromechanical relays, fuses and discrete circuits
- Driver for electromagnetic relays
- Power management for high-side-switching with low current consumption in OFF-mode x

Key Benefits

- Benchmark energy robustness
- Especially suitable for switching inductive loads
- High voltage capability (up to 58V)
- Fast switching capability (up to 1kHz)
- Low current consumption
- CMOS compatible input
- Protection features: overtemperature, short circuit, overload, current limitation, open load detection

Key Features

- Protection functions: short-circuit protection, overload protection, overtemperature protection, under- and overvoltage shutdown, loss-of-ground and loss-of- V_{bb} protection, reverse battery protection, ESD protection
- Available with diagnosis functions
- Wide operating voltage range up to 58V
- CMOS-compatible input
- PWM capability
- Improved Electromagnetic Compatibility (EMV)
- Very low standby current
- Green/RoHS compliant



The New MiniPROFET™ Family – Protected High-Side Switches for Industrial Applications

Block Diagram

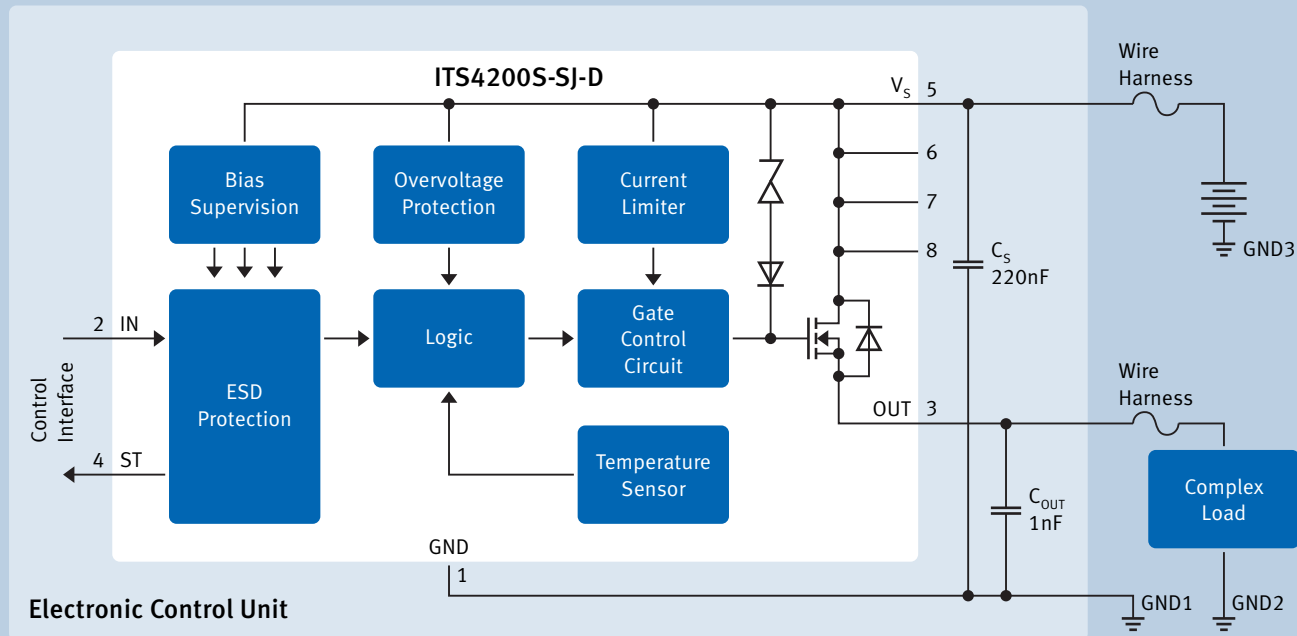

Product Table

| Product | $R_{DS(on)}$ @ $T_j = 25^\circ\text{C}$ [mΩ] | Load Current (min.) [A] | Load Current (typ.) [A] | $I_{L(SC)}$ (typ.) [A] | E_{AS} [mJ] | Recommended Operating Voltage Range [V] | Diagnosis | Package |
|---------------|---|----------------------------|----------------------------|---------------------------|------------------|--|-----------|----------|
| ITS41K0S-ME-N | 1000 | 0.2 | 0.55 | 0.9 | 1000 @ 0.15A | 4.9 ... 60.0 | N/A | SOT223 |
| ITS4200S-ME-O | 150 | 0.7 | 1.1 | 1.4 | 700 @ 0.5A | 12.0 ... 45.0 | N/A | SOT223 |
| ITS4200S-ME-P | 150 | 1.4 | 2.2 | 3.0 | 160 @ 1A | 12.0 ... 45.0 | N/A | SOT223 |
| ITS4200S-ME-N | 160 | 0.7 | 1.2 | 1.5 | 500 @ 0.5A | 5.0 ... 34.0 | N/A | SOT223 |
| ITS4060S-SJ-N | 50 | 2.6 | 3.1 | 17.0 | 900 @ 1.5A | 5.0 ... 34.0 | N/A | PG-DSO-8 |
| ITS4100S-SJ-N | 70 | 2.0 | 2.4 | 10.0 | 870 @ 1A | 5.0 ... 34.0 | N/A | PG-DSO-8 |
| ITS4200S-SJ-D | 150 | 1.3 | 1.7 | 6.5 | 125 @ 1A | 6.0 ... 52.0 | Digital | PG-DSO-8 |
| ITS4300S-SJ-D | 250 | 0.4 | 0.8 | 1.2 | 800 @ 300mA | 5.0 ... 34.0 | Digital | PG-DSO-8 |

Published by
Infineon Technologies AG
85579 Neubiberg, Germany

© 2012 Infineon Technologies AG.
All Rights Reserved.

Visit us:
www.infineon.com

Order Number: B124-H9739-X-X-7600
Date: 08 / 2012

ATTENTION PLEASE!

The information given in this document shall in no event be regarded as a guarantee of conditions or characteristics ("Beschaffenheitsgarantie"). With respect to any examples or hints given herein, any typical values stated herein and/or any information regarding the application of the device, Infineon Technologies hereby disclaims any and all warranties and liabilities of any kind, including without limitation warranties of non-infringement of intellectual property rights of any third party.

INFORMATION

For further information on technology, delivery terms and conditions and prices please contact your nearest Infineon Technologies Office (www.infineon.com).

WARNINGS

Due to technical requirements components may contain dangerous substances. For information on the types in question please contact your nearest Infineon Technologies Office. Infineon Technologies Components may only be used in life-support devices or systems with the express written approval of Infineon Technologies, if a failure of such components can reasonably be expected to cause the failure of that life-support device or system, or to affect the safety or effectiveness of that device or system. Life support devices or systems are intended to be implanted in the human body, or to support and/or maintain and sustain and/or protect human life. If they fail, it is reasonable to assume that the health of the user or other persons may be endangered.