

Package Outline

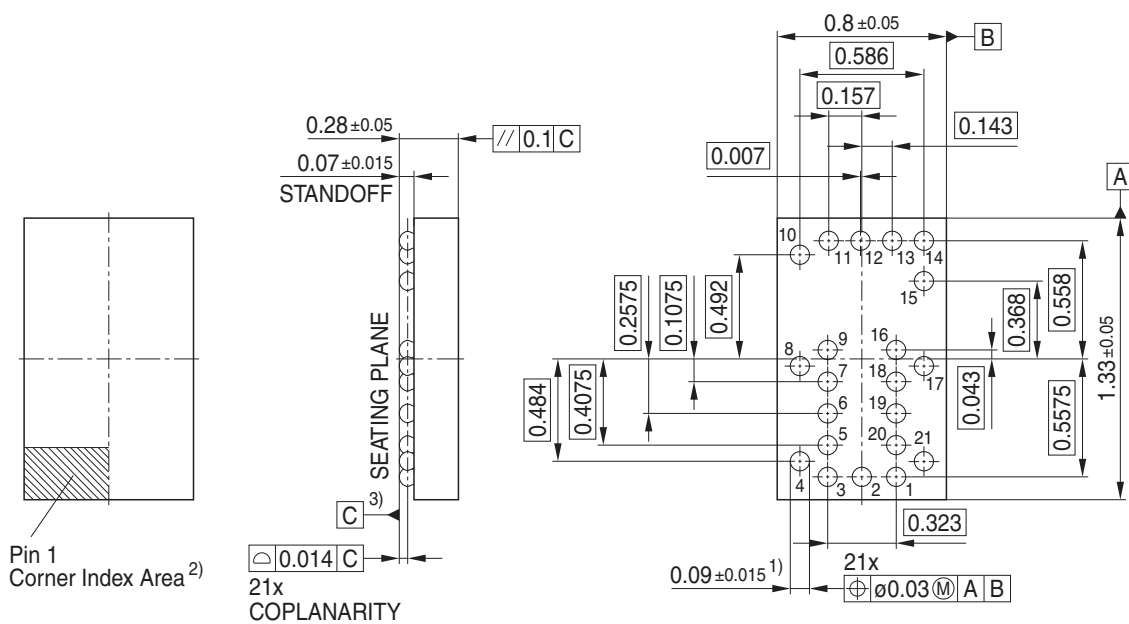

- 1) Dimension is measured at the maximum solder ball diameter, parallel to primary datum C
- 2) Pin 1 corner identified by marking
- 3) Primary datum C and seating plane are defined by the domed crowns of the balls

Foot Print

Soldering Type: Reflow Soldering

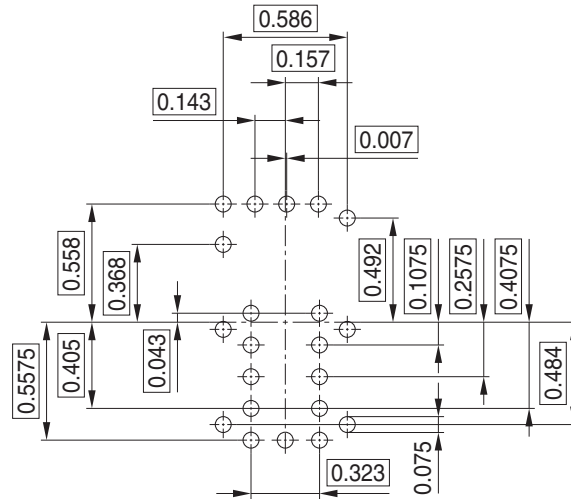

Marking Layout

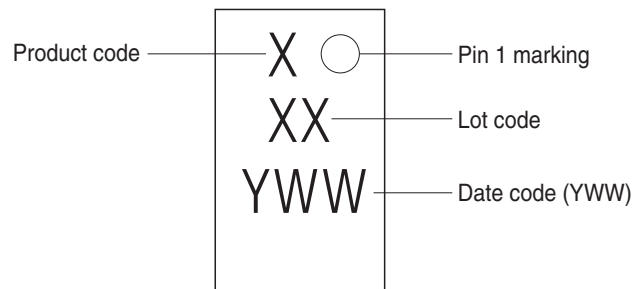

Tape and Reel

Reel \varnothing 180 mm: 14.000 Pieces/Reel
 Reels/Box: 1

