

Package Outline

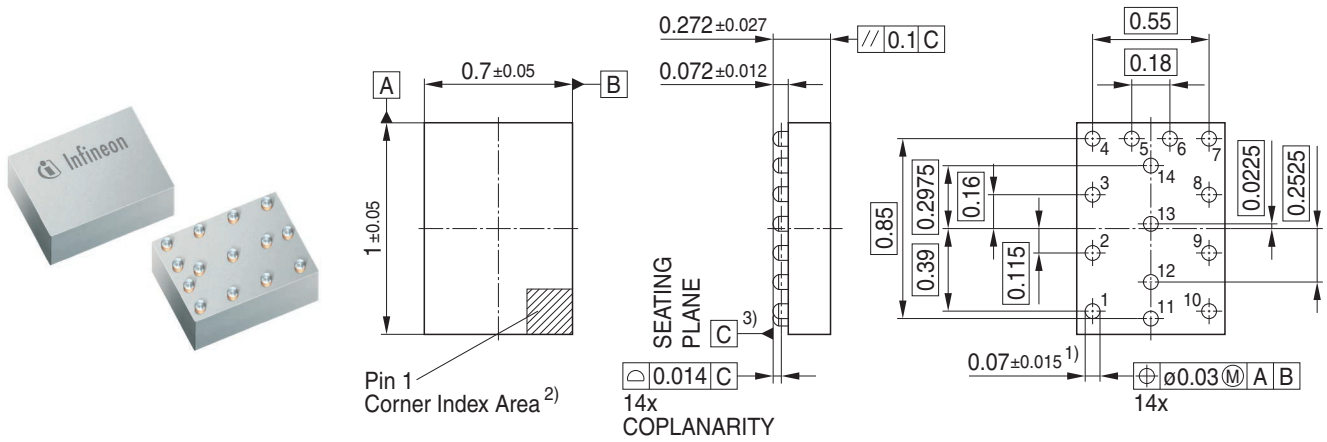

Foot Print

Soldering Type: Reflow Soldering

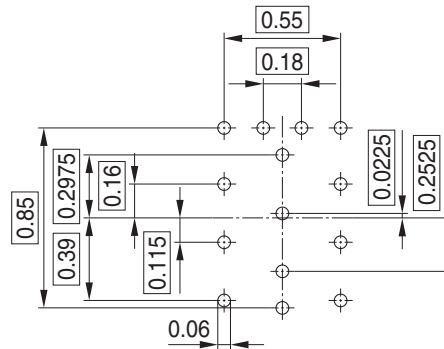

Marking Layout

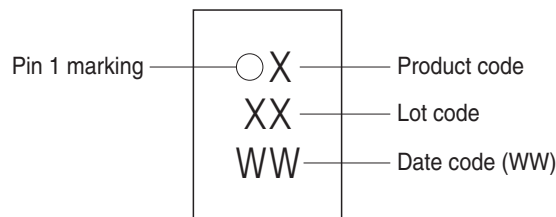

Tape and Reel

Reel ϕ 180 mm: 12.000 Pieces/Reel
Reels/Box: 1

