



DSL70

Superior ESD & Transient protection on ADSL, VDSL and other broadband applications

Best in market protection solution supporting efficient BOM optimization.

DSL70 is the protection diode selected to be integrated into the newest ADSL/VDSL schematics from leading design groups.

Customers rate DSL70 as preferred solution because of its very low forward voltage at high peak currents, lowest capacitance and overall superior surge absorption performance than any other comparable device in the market. This benchmark performance in combination with a very competitive price makes the DSL70 the device of choice in the protection arena, well ahead of others.

Applications

Low capacitance DSL 70 diode is designed to protect sensitive equipment in applications like:

- xDSL (ADSL, VDSL) interfaces (on secondary side of transformer)
- ISDN
- WLAN
- LAN,
- I2C Bus
- Microcontroller inputs
- Video

Ordering Code: SP000362209

Application Board: SP000417036

Product Summary

Parameter	Ratings	Conditions
V_{ESD} (Electrostatic Discharge)	±15kV	IEC61000-4-2 (contact)
V_{EFT} (Electro Fast Transients)	4 kV / 80A	IEC61000-4-4 (5/50ns)
Surge	27A	IEC61000-4-5 (8/20µs)
Forward Clamping Voltage (Vfc)	6V	At surge 27A (8/20µs)
Capacitance (typical)	2.5pF	1MHz, 0V

Customer Values

- Highly reliable protection against transients and ESD events exceeding IEC standard
- Lowest forward-clamping voltage while handling the highest surge currents
- Lowest capacitance to fulfill quality requirements of DSL high-speed signal
- Optimized to enable compliance with telecommunication regulatory requirements like:
 - ITU K20/21 Surge: 10/700us, 4000V (with gas discharge tube, GDT) 10/700us, 1500V (without GDT)
 - ITU K20/21 Power Induction: 1sec, 600V, 600 Ohm (with GDT) 0.2sec, 600V, 600Ohm (without GDT)
 - ITU K20/21 Power Contact: 15min, 230V, 160 Ohm (without GDT)
- Designed in SOT143 (SC-61A) market standard package for two-line protection

DSL70

Superior ESD & Transient protection on ADSL, VDSL and other broadband applications.

Application Example: Efficient protection on xDSL with DSL70 diode

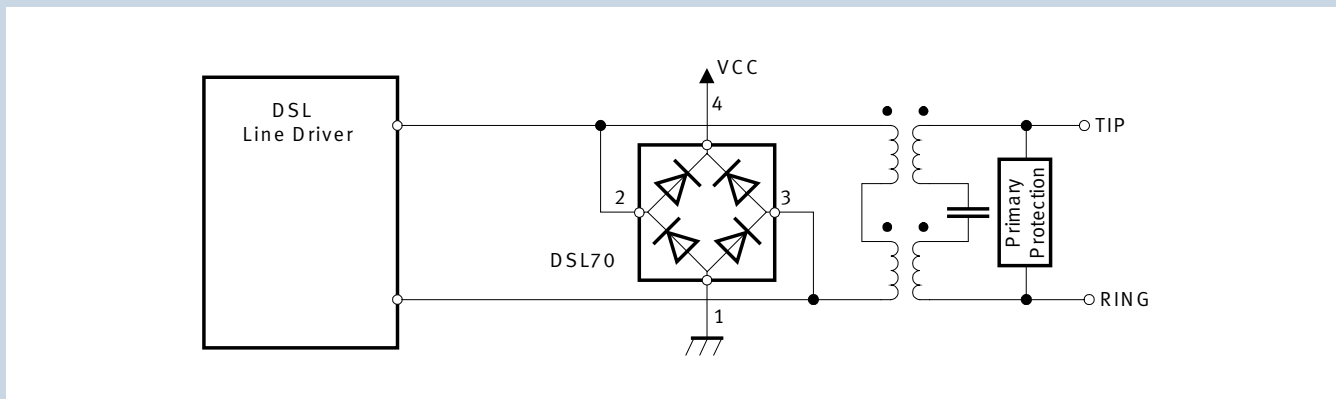

Package Outline and Footprint

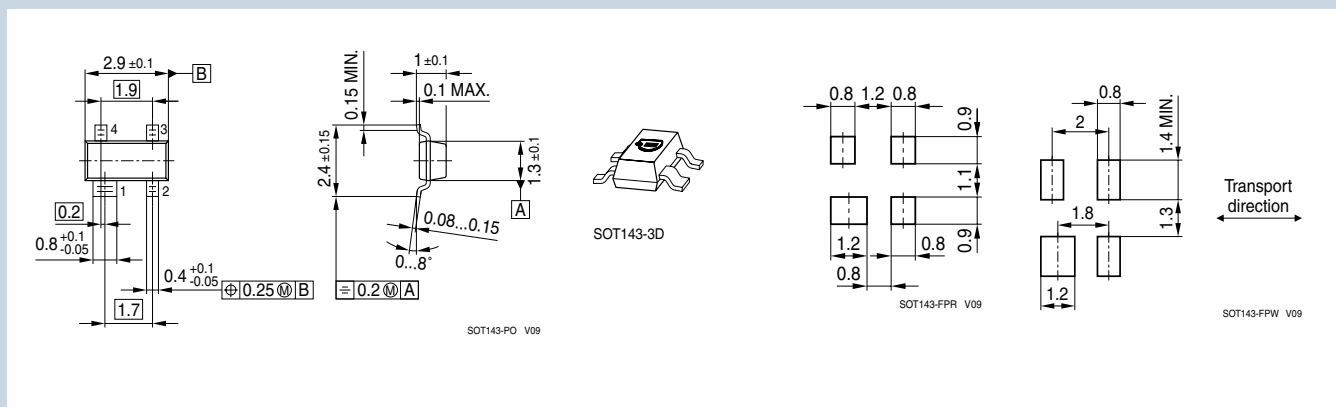

How to reach us:
<http://www.infineon.com>

Published by
 Infineon Technologies AG
 81726 Munich, Germany

© 2008 Infineon Technologies AG
 All Rights Reserved.

Legal Disclaimer The information given in this Product Brief shall in no event be regarded as a guarantee of conditions or characteristics. With respect to any examples or hints given herein, any typical values stated herein and/or any information regarding the application of the device, Infineon Technologies hereby disclaims any and all warranties and liabilities of any kind, including without limitation, warranties of non-infringement of intellectual property rights of any third party.

Information For further information on technology, delivery terms and conditions and prices, please contact the nearest Infineon Technologies Office (www.infineon.com).

Warnings Due to technical requirements, components may contain dangerous substances. For information on the types in question, please contact the nearest Infineon Technologies Office. Infineon Technologies components may be used in life-support devices or systems only with the express written approval of Infineon Technologies, if a failure of such components can reasonably be expected to cause the failure of that life-support device or system or to affect the safety or effectiveness of that device or system. Life support devices or systems are intended to be implanted in the human body or to support and/or maintain and sustain and/or protect human life. If they fail, it is reasonable to assume that the health of the user or other persons may be endangered.