

# Evaluation Board

For XMC4000 Family

## XMC4500 Relax Kit & XMC4500 Relax Lite Kit

Kit Version 1

## Board User's Manual

Revision 1.2, 2014-01-13

Microcontroller

**Edition 2014-01-13**

**Published by  
Infineon Technologies AG  
81726 Munich, Germany**

**© 2014 Infineon Technologies AG  
All Rights Reserved.**

### **Legal Disclaimer**

The information given in this document shall in no event be regarded as a guarantee of conditions or characteristics. With respect to any examples or hints given herein, any typical values stated herein and/or any information regarding the application of the device, Infineon Technologies hereby disclaims any and all warranties and liabilities of any kind, including without limitation, warranties of non-infringement of intellectual property rights of any third party.

### **Information**

For further information on technology, delivery terms and conditions and prices, please contact the nearest Infineon Technologies Office ([www.infineon.com](http://www.infineon.com)).

### **Warnings**

Due to technical requirements, components may contain dangerous substances. For information on the types in question, please contact the nearest Infineon Technologies Office.

Infineon Technologies components may be used in life-support devices or systems only with the express written approval of Infineon Technologies, if a failure of such components can reasonably be expected to cause the failure of that life-support device or system or to affect the safety or effectiveness of that device or system. Life support devices or systems are intended to be implanted in the human body or to support and/or maintain and sustain and/or protect human life. If they fail, it is reasonable to assume that the health of the user or other persons may be endangered.

## Revision History

Page or Item	Subjects (major changes since previous revision)
Revision 1.0, 2012-11-07	Initial release
Revision 1.1, 2012-11-09	Correction of DAVE™3 trademark
Revision 1.2, 2014-01-13	Notes have been added to Figure 5 (Pins of Pin Header X1 / X2 are partly used also for on-board circuits)

## Trademarks of Infineon Technologies AG

AURIX™, C166™, CanPAK™, CIPOS™, CIPURSE™, EconoPACK™, CoolMOS™, CoolSET™, CORECONTROL™, CROSSAVE™, DAVE™, EasyPIM™, EconoBRIDGE™, EconoDUAL™, EconoPIM™, EiceDRIVER™, eupec™, FCOS™, HITFET™, HybridPACK™, I<sup>2</sup>RF™, ISOFACE™, IsoPACK™, MIPAQ™, ModSTACK™, my-d™, NovalithIC™, OptiMOS™, ORIGA™, PRIMARION™, PrimePACK™, PrimeSTACK™, PRO-SIL™, PROFET™, RASIC™, ReverSave™, SatRIC™, SIEGET™, SINDRION™, SIPMOS™, SmartLEWIS™, SOLID FLASH™, TEMPFET™, thinQ!™, TRENCHSTOP™, TriCore™.

## Other Trademarks

Advance Design System™ (ADS) of Agilent Technologies, AMBA™, ARM™, MULTI-ICE™, KEIL™, PRIMECELL™, REALVIEW™, THUMB™, μVision™ of ARM Limited, UK. AUTOSAR™ is licensed by AUTOSAR development partnership. Bluetooth™ of Bluetooth SIG Inc. CAT-iq™ of DECT Forum. COLOSSUS™, FirstGPS™ of Trimble Navigation Ltd. EMV™ of EMVCo, LLC (Visa Holdings Inc.). EPCOS™ of Epcos AG. FLEXGO™ of Microsoft Corporation. FlexRay™ is licensed by FlexRay Consortium. HYPERTERMINAL™ of Hilgraeve Incorporated. IEC™ of Commission Electrotechnique Internationale. IrDA™ of Infrared Data Association Corporation. ISO™ of INTERNATIONAL ORGANIZATION FOR STANDARDIZATION. MATLAB™ of MathWorks, Inc. MAXIM™ of Maxim Integrated Products, Inc. MICROTEC™, NUCLEUS™ of Mentor Graphics Corporation. Mifare™ of NXP. MIPI™ of MIPI Alliance, Inc. MIPS™ of MIPS Technologies, Inc., USA. muRata™ of MURATA MANUFACTURING CO., MICROWAVE OFFICE™ (MWO) of Applied Wave Research Inc., OmniVision™ of OmniVision Technologies, Inc. Openwave™ Openwave Systems Inc. RED HAT™ Red Hat, Inc. RFMD™ RF Micro Devices, Inc. SIRIUS™ of Sirius Satellite Radio Inc. SOLARIS™ of Sun Microsystems, Inc. SPANSION™ of Spansion LLC Ltd. Symbian™ of Symbian Software Limited. TAIYO YUDEN™ of Taiyo Yuden Co. TEAKLITE™ of CEVA, Inc. TEKTRONIX™ of Tektronix Inc. TOKO™ of TOKO KABUSHIKI KAISHA TA. UNIX™ of X/Open Company Limited. VERILOG™, PALLADIUM™ of Cadence Design Systems, Inc. VLYNQ™ of Texas Instruments Incorporated. VXWORKS™, WIND RIVER™ of WIND RIVER SYSTEMS, INC. ZETEX™ of Diodes Zetex Limited.

Last Trademarks Update 2011-02-24

## Table of Contents

<b>Introduction</b> .....	<b>7</b>
<b>1 Overview</b> .....	<b>7</b>
1.1 Key Features .....	7
1.2 Block Diagram .....	8
<b>2 Hardware Description</b> .....	<b>9</b>
2.1 Power Supply .....	11
2.2 Pin Header Connector .....	12
<b>3 Production Data</b> .....	<b>14</b>
3.1 Schematics .....	14
3.2 Components Placement and Geometry .....	17
3.3 List of Material .....	18

## List of Figures

Figure 1	Block Diagram of the XMC4500 Relax/Relax Lite Kit-V1.....	8
Figure 2	XMC4500 Relax Lite Kit-V1 .....	9
Figure 3	XMC4500 Relax Kit-V1 .....	10
Figure 4	Power Supply Concept.....	11
Figure 5	Signal mapping of the pin headers.....	12
Figure 6	Mapping of communication peripherals to GPIOs and it's corresponding functions .....	13
Figure 7	CPU, Pin Headers, Buttons, LEDs, Reset .....	15
Figure 8	On-board Debugger, Power Supply, Ethernet, Quad-SPI Memory, SD Card Slot, RTC Crystal .....	16
Figure 9	Components Placement and Geometry .....	17



## List of Tables

Table 1	Features .....	7
Table 2	List of Material .....	18

## Introduction

This document describes the features and hardware details of the XMC4500 Relax Kit-V1 and the XMC4500 Relax Lite Kit-V1, both equipped with the ARM® Cortex™-M4 based XMC4500 Microcontroller from Infineon Technologies AG.

## 1 Overview

The XMC4500 Relax Kit-V1 and the XMC4500 Relax Lite Kit-V1 are designed to evaluate the capabilities of the XMC4500 Microcontroller and the powerful, free of charge tool chain DAVE™. The XMC4500 Relax Kit extends the feature set with an Ethernet-enabled communication option, e.g. to run an embedded web server. You can store your own HTML web pages on a microSD Card or control the XMC4500 via the web browser on your PC. The XMC4500 Relax Lite Kit-V1 does not support the web server application, because the components for the Ethernet are not assembled. Both boards are marked with “XMC4500 Relax/Relax Lite Kit-V1”. These boards are neither cost nor size optimized and do not serve as a reference design.

### 1.1 Key Features

Table 1 summarizes the features of both the XMC4500 Relax Kit-V1 and the XMC4500 Relax Lite Kit-V1.

**Table 1 Features**

Feature	XMC4500 Relax Kit-V1	XMC4500 Relax Lite Kit-V1
XMC4500 Microcontroller (ARM® Cortex™-M4F based)	✓	✓
Detachable on-board Debugger	✓	✓
Power over USB	✓	✓
2 x User Button and 2 x User LED	✓	✓
Reset Button	✓	✓
Power Regulator from 5 V to 3.3V	✓	✓
4 x SPI-Master, 3x I2C, 3 x I2S, 3 x UART, 2 x CAN, 17 x ADC (12 bit), 2 x DAC, 31x PMW mapped on 2 Pin Headers 2 x 20	✓	✓
USB-OTG (Micro USB Plug)	✓	✓
Ethernet PHY and RJ45 jack	✓	
Real Time Clock Crystal	✓	
32 Mbit Quad-SPI Flash Memory	✓	
microSD Card Slot	✓	

## 1.2 Block Diagram

The block diagram in Figure 1 shows the main components of the XMC4500 Relax/Relax Lite Kit-V1 and their interconnections. There are following main building blocks:

- XMC4500 Microcontroller in a LQFP100 package
- On-board USB debugger realized with a 2<sup>nd</sup> XMC4500 for serial wire debug
- Ethernet Phy with RJ45 Plug
- Two 40 pin header X1 and X2
- On-board power generation for power supply of the XMC4500 Microcontroller and the debug IC
- 2 User Buttons and 2 User LEDs
- USB Plug
- microSD Card Slot

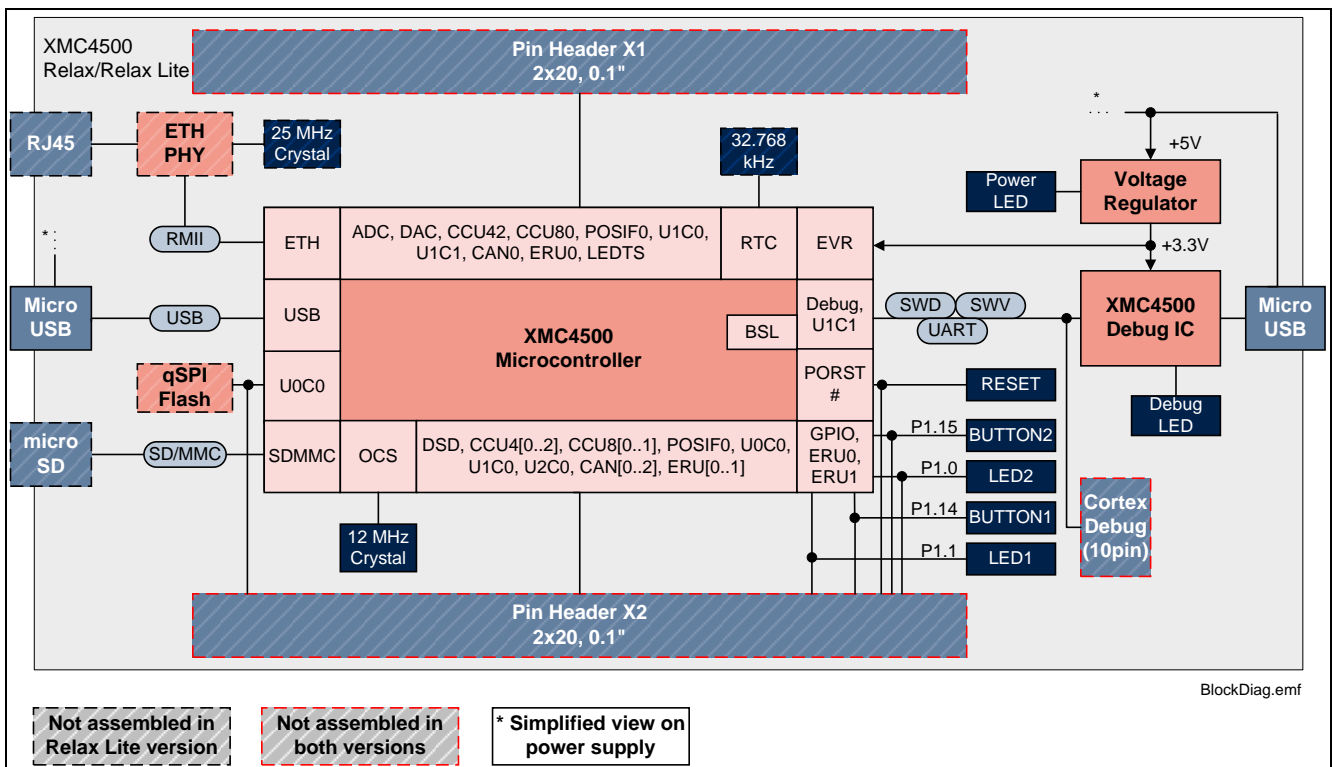
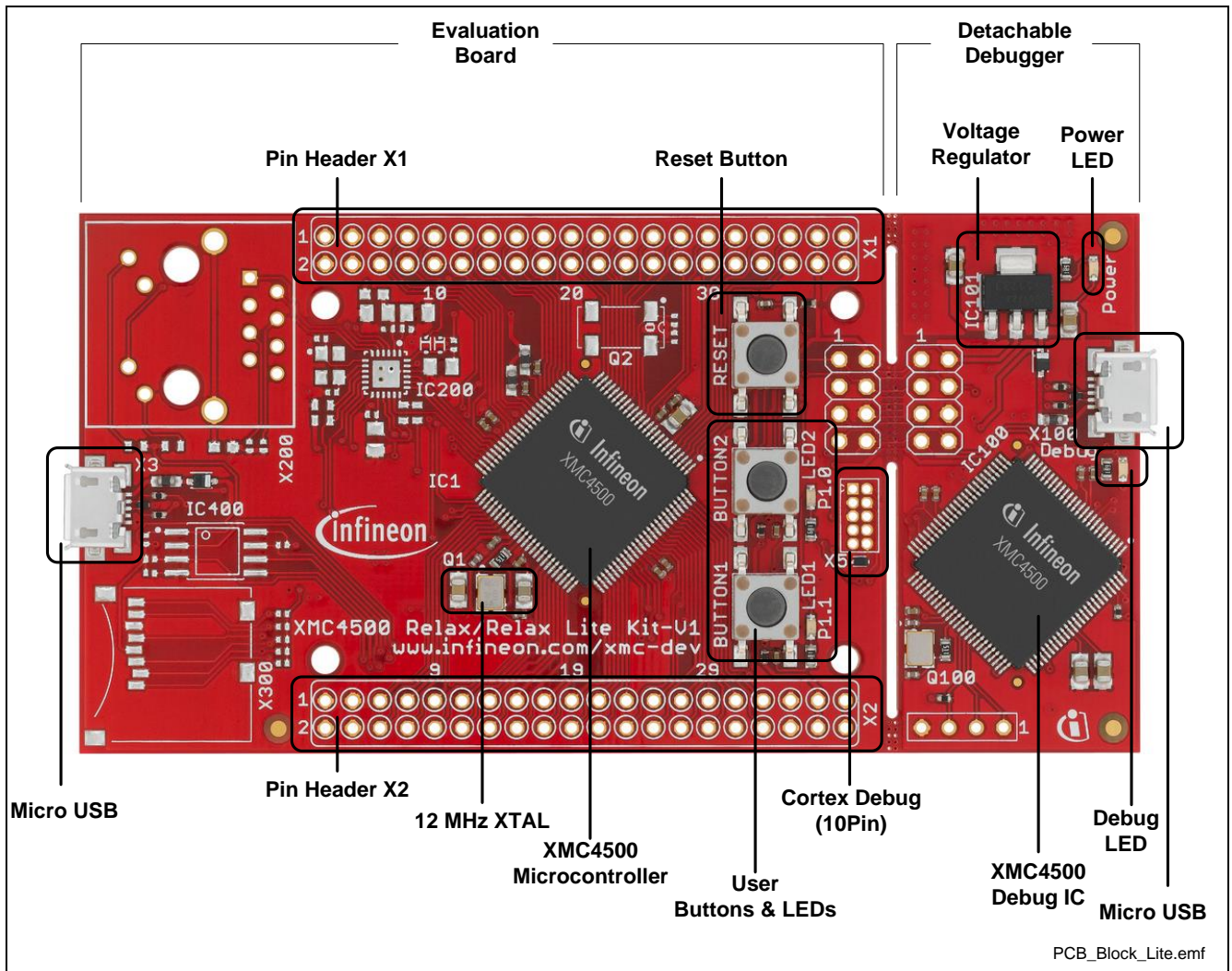

**Figure 1** Block Diagram of the XMC4500 Relax/Relax Lite Kit-V1



## 2 Hardware Description

The following sections give a detailed description of the board hardware and how it can be used. Figure 2 shows the XMC4500 Relax Lite Kit-V1, Figure 3 shows the XMC4500 Relax Kit-V1.



**Figure 2 XMC4500 Relax Lite Kit-V1**

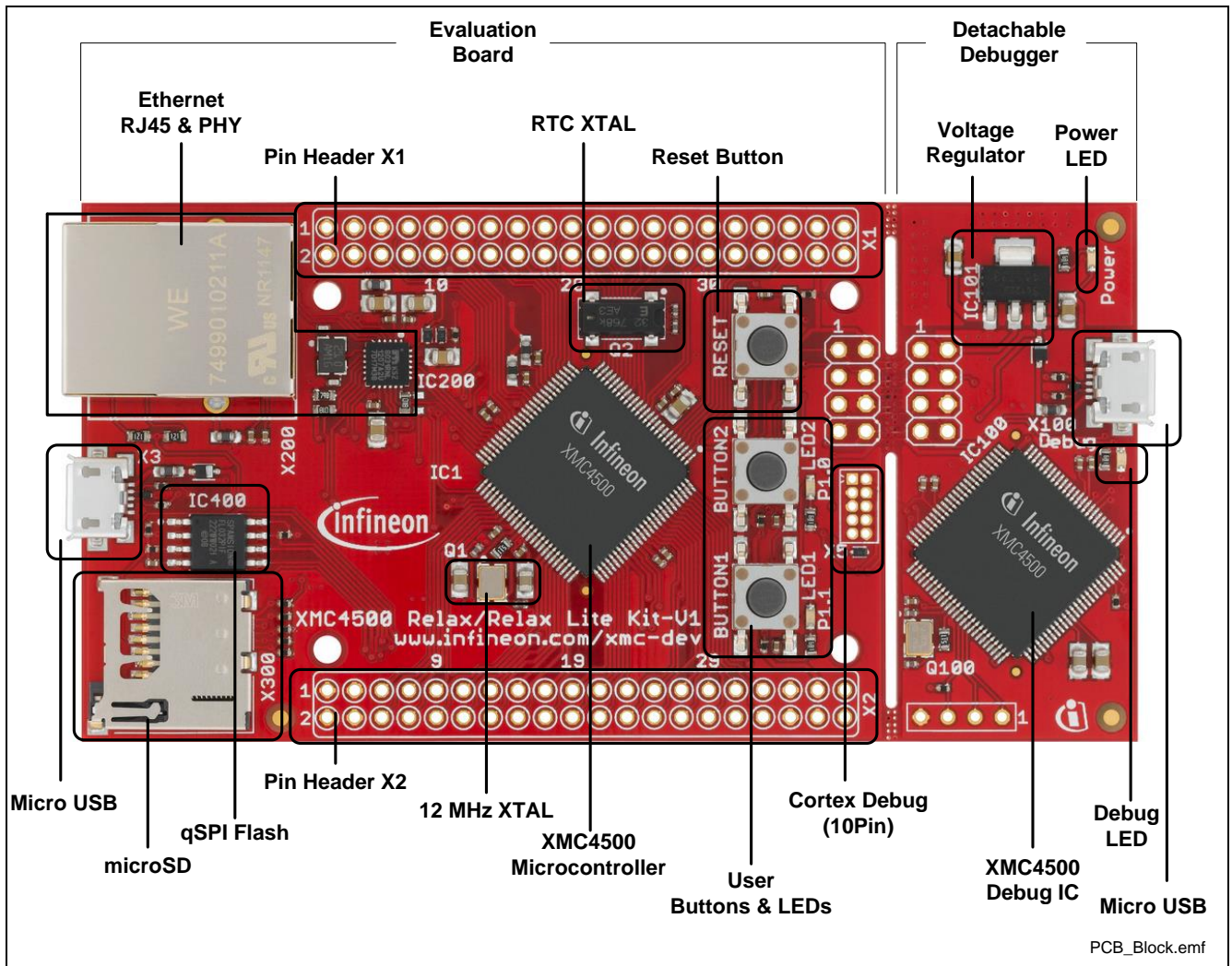

Figure 3 XMC4500 Relax Kit-V1

## 2.1 Power Supply

The XMC4500 Relax/Relax Lite Kit-V1 must be supplied by an external 5 Volt DC power supply connected to any of the Micro USB plugs (X3, X100). Out of the box with the pre-programmed web server application and the on-board debugger in operation the XMC4500 Relax Kit-V1 typically draws about 250 mA. The XMC4500 Relax Lite Kit-V1 without the web server capabilities draws about 200 mA. This current can be delivered via the USB plug of a PC, which is specified to deliver up to 500 mA. The Power LED indicates the presence of the generated 3.3V supply voltage.

On-board reverse current protection diodes will ensure safe operation in case power is provided through both USB plugs at the same time. These protection diodes allows to use the on-board debugger connected with a PC/Notebook via X100 and a second host PC/Laptop connected with the XMC4500 Relax Kit via X3.

If the board is powered via a USB plug, it's not recommended to apply an additional 5 Volt power supply to one of the 5 Volt power pins (VDD5) on the pin headers X1 or X2, because there is no protection against reverse current into the external power supply. These power pins can be used to power an external circuit. But care must be taken not to draw more current than USB can deliver. A PCs as USB host typically can deliver up to 500 mA current. If higher currents are required and in order to avoid damages on the USB host the use of an external USB power supply unit which is able to deliver higher currents than 500 mA is strongly recommended.

After power-up the Debug LED starts blinking. In case there is a connection to a PC via the Debug USB plug X100 and the USB Debug Device drivers are installed on this PC, the Debug LED will turn from blinking to constant illumination.

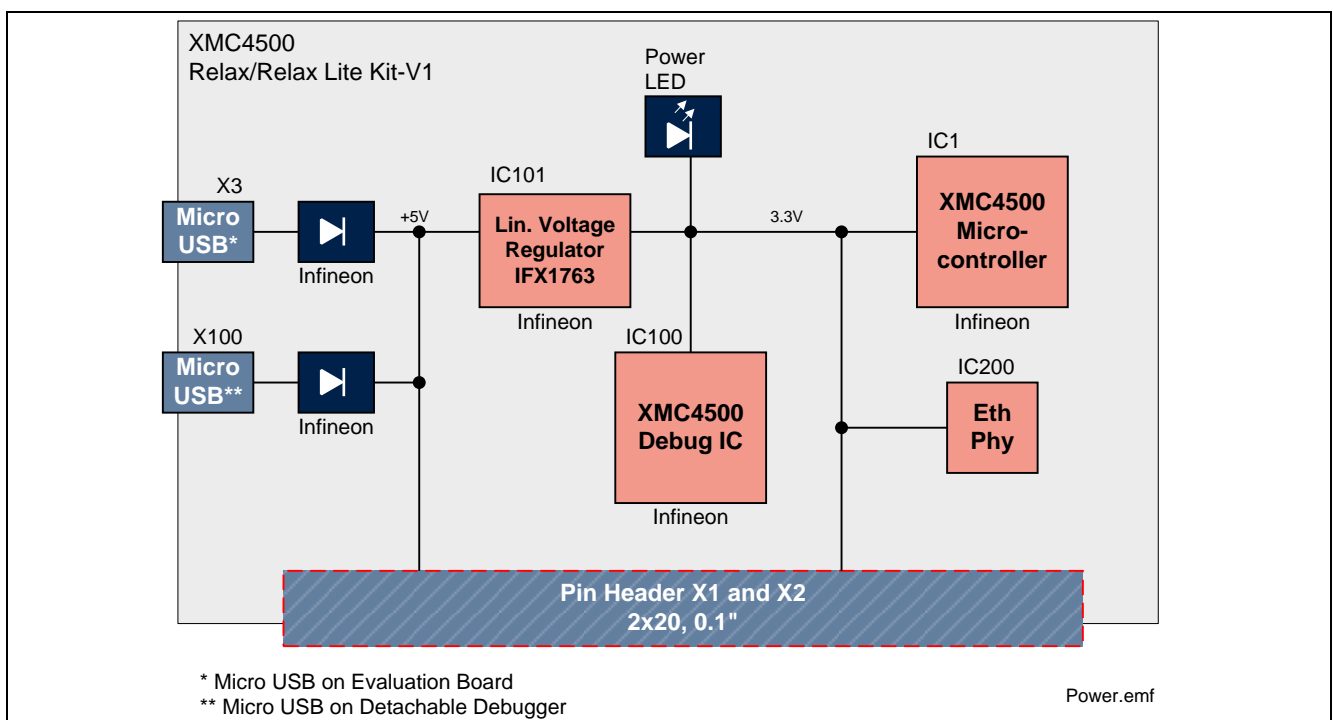

**Figure 4 Power Supply Concept**

## 2.2 Pin Header Connector

The pin headers X1 and X2 can be used to extend the evaluation board or to perform measurements on the XMC4500. Figure 5 shows the available GPIOs/signals at the pin headers. The pinning table is also printed onto the bottom side of the PCB.

Pin Header X2				(Top View)	Pin Header X1			
2		1			2		1	
	GND		GND			GND		GND
4	GND		GND	3	4	GND		GND
6	P5.7		P2.6	5	6	RESET#		GND
8	P5.1		P5.2	7	8	P2.10		P2.1
10	P1.15**		P5.0	<b>9</b>	<b>10</b>	P14.8		P2.14
12	P1.13		P1.14**	11	12	P14.9		P2.15
14	P1.11		P1.12	13	14	P14.0		VAREF
16	P1.5***		P1.10***	15	16	P14.2		P14.1
18	P1.3***		P1.4***	17	18	P14.4		P14.3
20	P1.1*		P1.2***	<b>19</b>	<b>20</b>	P14.6		P14.5
22	P1.9		P1.0*	21	22	P14.12		P14.7
24	P0.8		P1.8***	23	24	P14.14		P14.13
26	P3.4		P0.7	25	26	P15.2		P14.15
28	P0.12		P3.3	27	28	HIB_IO_0		P15.3
30	P0.6		P0.11	<b>29</b>	<b>30</b>	P3.0		HIB_IO_1
32	P0.2		P0.5	31	32	P3.2		P3.1
34	P0.4		P0.3	33	34	P0.1		P0.9
36	GND		GND	35	36	P0.0		P0.10
38	VDD3.3		VDD3.3	37	38	VDD3.3		VDD3.3
40	VDD5		VDD5	39	40	VDD5		VDD5

\* P1.1 is connected to LED1, P1.0 is connected to LED2 (2 mA load, ~2 V clip of input signal)  
 \*\* P1.14 is connected to BUTTON1, P1.15 is connected to BUTTON 2 (both with a 100 nF capacitor in parallel)  
 \*\*\* These pins are connected to the on-board SPI Flash Memory (not valid for Relax Lite):  
 X2.23 = Port 1.8 = SPI Flash CS#  
 X2.15 = Port 1.10 = SPI Flash CLK  
 X2.16 = Port 1.5 = SPI Flash DI (IO0)  
 X2.17 = Port 1.4 = SPI Flash DO (IO1)  
 X2.18 = Port 1.3 = SPI Flash WP# (IO2)  
 X2.19 = Port 1.2 = SPI Flash HOLD# (IO3)

**Figure 5 Signal mapping of the pin headers**

The XMC4500 provides a flexible mapping of functions to different pins. Figure 6 shows an example how the communication peripheral functions UART, I2C, SPI, CAN and I2S can be mapped to XMC4500's GPIOs.

GPIOs with the same colour code belong to the same group of physical pins and cannot be chosen twice. For instance UART-3 has got a pin overlap with I2C-Master1 and therefore this combination cannot work in parallel.

Please also avoid peripheral combinations which are using the same USIC channel. For example I2C-Master2 and UART-3 utilizing USIC 0 Channel 0 (U0C0), therefore this combination does not work in parallel.

<b>UART</b>		<b>UART-1</b>	<b>UART-2</b>	<b>UART-3</b>	<b>UART-4</b>
<b>TX</b>		P0.1 / U1C1.DOUT0	P1.5 / U0C0.DOUT0	P5.1 / U0C0.DOUT0	P0.5 / U1C0.DOUT0
<b>RX</b>		P0.0 / U1C1.DX0D	P1.4 / U0C0.DX0B	P5.0 / U0C0.DX0D	P0.4 / U1C0.DX0A

<b>I2C Master/Slave</b>		<b>I2C-Master1</b>	<b>I2C-Master2</b>	<b>I2C-Master3</b>	<b>I2C-Slave1</b>	<b>I2C-Slave2</b>
<b>SCL (clock)</b>		P5.2 / U2C0.SCLKOUT	P1.10 / U0C0.SCLKOUT	P0.11 / U1C0.SCLKOUT	P5.2 / U2C0.DX1A	P0.11 / U1C0.DX1A
<b>SDA (data)</b>		P5.0 / U2C0.DOUT0 / .DX0B	P1.5 / U0C0.DOUT0 / .DX0A	P0.5 / U1C0.DOUT0 / .DX0B	P5.0 / U2C0.DOUT0 / .DX0B	P0.5 / U1C0.DOUT0 / .DX0B

<b>SPI Master/Slave</b>		<b>SPI-Master1</b>	<b>SPI-Master2</b>	<b>SPI-Master3</b>	<b>SPI-Master4</b>	<b>SPI-Slave1</b>	<b>SPI-Slave2</b>
<b>MOSI</b>		P0.1 / U1C1.DOUT0	P5.0 / U2C0.DOUT0	P1.5 / U0C0.DOUT0	P0.5 / U1C0.DOUT0	P0.0 / U1C1.DX0D	P0.4 / U1C0.DX0A
<b>MISO</b>		P0.0 / U1C1.DX0D	P5.1 / U2C0.DX0A	P1.4 / U0C0.DX0B	P0.4 / U1C0.DX0A	P0.1 / U1C1.DOUT0	P0.5 / U1C0.DOUT0
<b>SCK (clock)</b>		P0.10 / U1C1.SCLKOUT	P5.2 / U2C0.SCLKOUT	P1.10 / U0C0.SCLKOUT	P0.11 / U1C0.SCLKOUT	P0.10 / U1C1.DX1A	P0.11 / U1C0.DX1A
<b>CS (chip select)</b>		P0.9 / U1C1.SELO0*	P2.6 / U2C0.SELO4	P1.11 / U0C0.SELO0**	P0.6 / U1C0.SELO0	P0.9 / U1C1.DX2A	P0.6 / U1C0.DX2A

<b>CAN</b>		<b>CAN-1</b>	<b>CAN-2</b>
<b>TX</b>		P1.12 / CAN.N1_TXD	P1.4 / CAN.N0_TXD
<b>RX</b>		P1.13 / CAN.N1_RXDC	P1.5 / CAN.N0_RXDA

<b>I2S Master/Slave</b>		<b>I2C-Master1</b>	<b>I2C-Master2</b>	<b>I2C-Master3</b>	<b>I2C-Slave1</b>
<b>SCK (clock)</b>		P5.2 / U2C0.SCLKOUT	P1.10 / U0C0.SCLKOUT	P0.11 / U1C0.SCLKOUT	P0.11 / U1C0.DX1A
<b>SD (data)</b>		P5.0 / U2C0.DOUT0 / .DX0B	P1.5 / U0C0.DOUT0 / .DX0A	P0.5 / U1C0.DOUT0 / .DX0B	P5.0 / U2C0.DOUT0 / .DX0B
<b>WS (wait)</b>		P2.6 / U2C0.SELO4	P1.11 / U0C0.SELO0	P0.6 / U1C0.SELO0	P0.6 / U2C0.DX2A

\* more chip select signals for U1C1 can be found at P3.3, P3.4, P3.5, P3.6  
 \*\* another chip select signal for U0C0 can be found at P1.8

**Figure 6 Mapping of communication peripherals to GPIOs and it's corresponding functions**

## **3 Production Data**

### **3.1 Schematics**

This chapter contains the schematics for the XMC4500 Relax/Relax Lite Kit-V1:

- Figure 7: CPU, Pin Headers, Buttons, LEDs, Reset
- Figure 8: On-board Debugger, Power Supply, Ethernet, Quad-SPI Memory, SD Card Slot, RTC Crystal

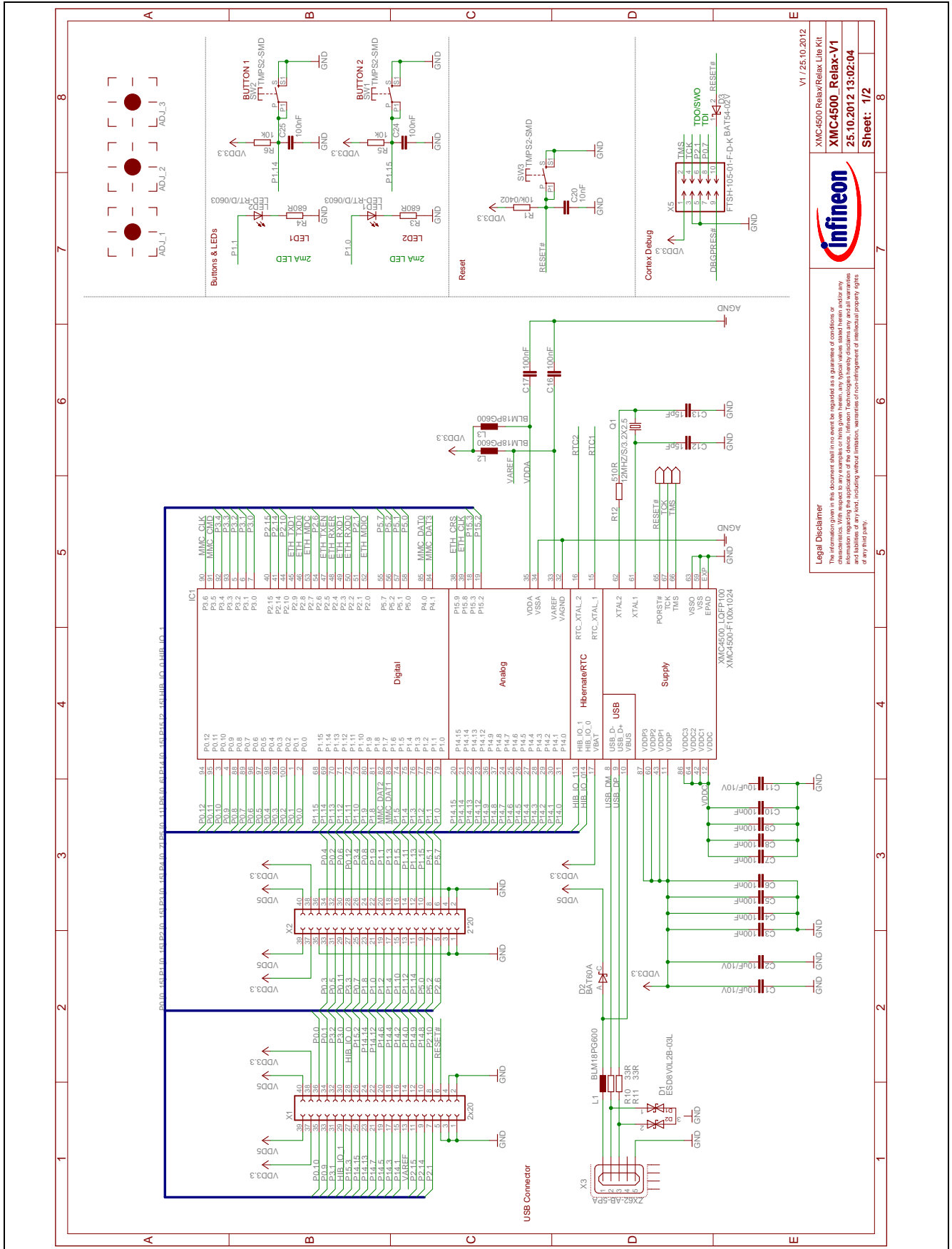

**Figure 7 CPU, Pin Headers, Buttons, LEDs, Reset**

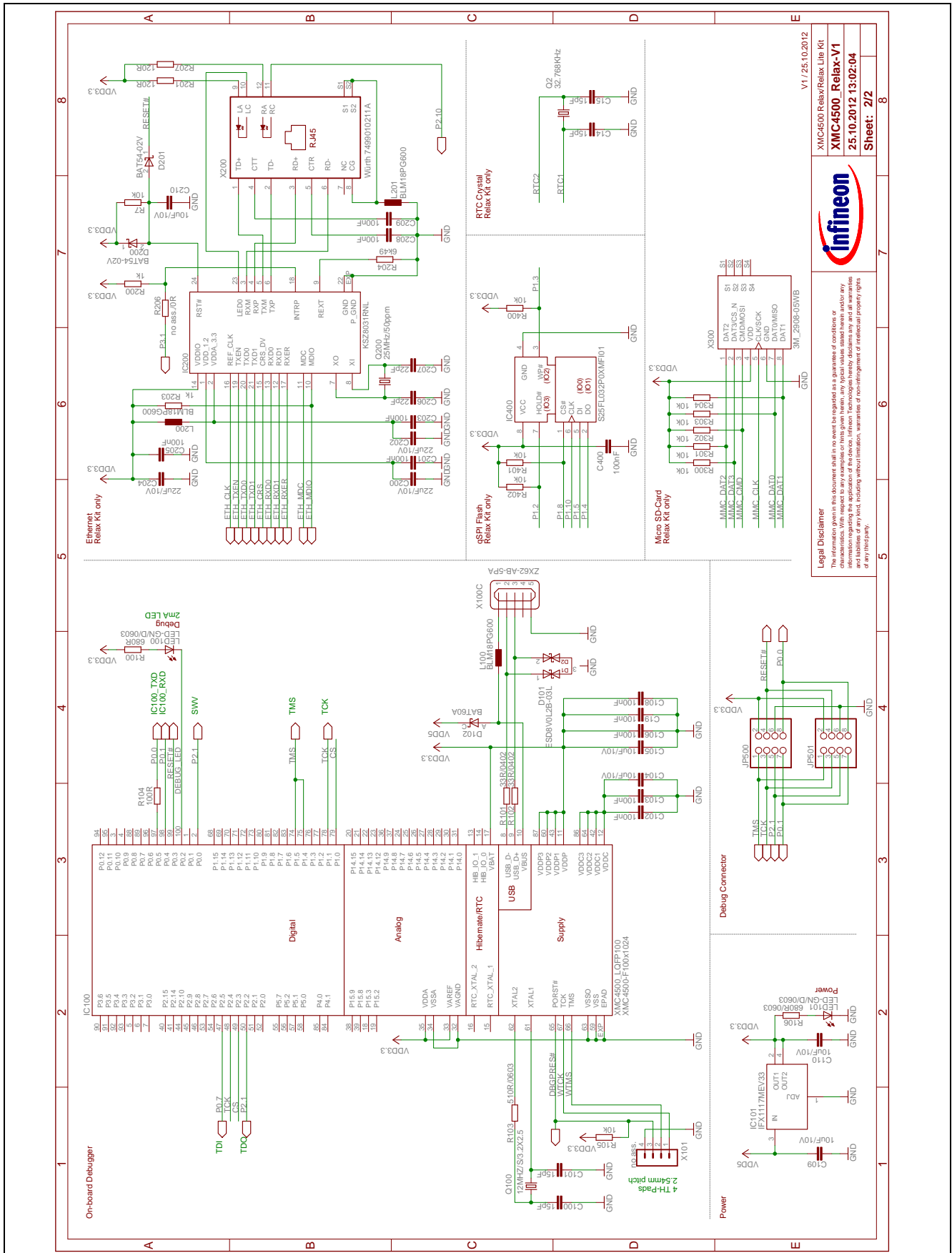

V1.25.10.2012

XMC4500 Relax/Lite Kit

**XMC4500 Relax-V1**

25.10.2012 13:02:04

Sheet: 2/2

**Infineon**

**Legal Disclaimer**  
The information given in this document shall in no event be regarded as a guarantee of conditions or characteristics. With respect to any examples or hints given herein, any typical values stated therein and/or any references to third party products, the user is authorized to use only the latest specifications and data sheets of any kind, including without limitation, variations of non-infringement of intellectual property rights of any third party.

Figure 8 On-board Debugger, Power Supply, Ethernet, Quad-SPI Memory, SD Card Slot, RTC Crystal



### 3.2 Components Placement and Geometry

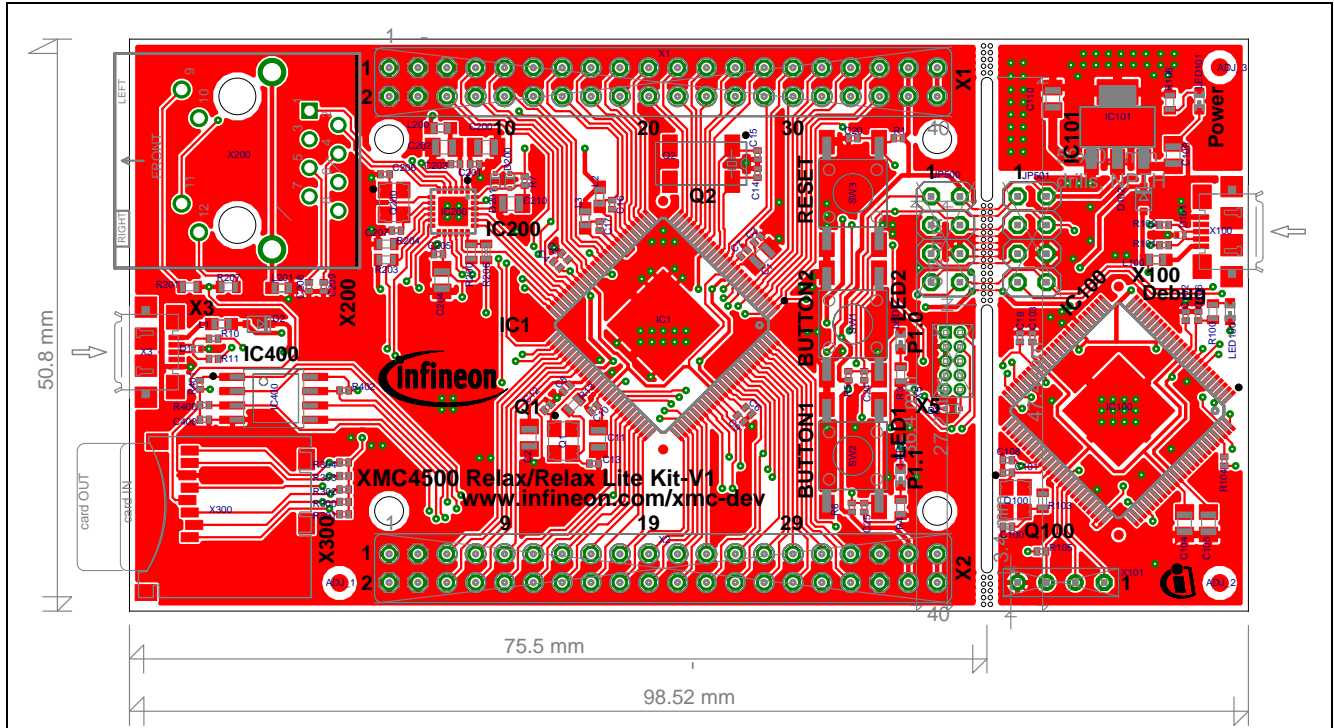

Figure 9 Components Placement and Geometry

### 3.3 List of Material

The list of material is valid for the XMC4500 Relax/Relax Lite Kit-V1.

**Table 2 List of Material**

No.	Qty	Value	Device	Reference Designator
1	2	2x4	Pin Header 0.1" TH	JP500, JP501
2	2	1k	Resistor	R200, R203
3	1	2*20	Pin Header 0.1" TH	X2
4	1	2x20	Pin Header 0.1" TH	X1
5	1	3M_2908-05WB	microSD Card Holder	X300
6	1	6k49	Resistor	R204
7	12	10k	Resistor	R5, R6, R7, R105, R300, R301, R302, R303, R304, R400, R401, R402
8	1	10k/0402	Resistor	R1
9	1	10nF	Capacitor	C20
10	8	10uF/10V	Capacitor	C1, C2, C11, C104, C105, C109, C110, C210
11	2	12MHz/S/3.2X2.5	Crystal 12 MHz	Q1, Q100
12	6	15pF	Capacitor	C12, C13, C14, C15, C100, C101
13	2	22pF	Capacitor	C206, C207
14	3	22uF/10V	Capacitor	C200, C202, C204
15	1	25MHz/50ppm	Crystal 12 MHz	Q200
16	1	32.768KHz	Crystal 32 kHz	Q2
17	2	33R	Resistor	R10, R11
18	2	33R/0402	Resistor	R101, R102
19	1	100R	Resistor	R104
20	23	100nF	Capacitor	C3, C4, C5, C6, C7, C8, C9, C10, C16, C17, C19, C24, C25, C102, C103, C106, C108, C201, C203, C205, C208, C209, C400
21	2	120R	Resistor	R201, R207
22	1	510R	Resistor	R12
23	1	510R/0603	Resistor	R103
24	3	680R	Resistor	R3, R4, R100
25	1	680R/0603	Resistor	R106
26	3	BAT54-02V	Schottky Diode, Infineon	D3, D200, D201
27	2	BAT60A	Schottky Diode, Infineon	D2, D102
28	6	BLM18PG600	Inductor	L1, L2, L3, L100, L200, L201
29	2	ESD8V0L2B-03L	TVS Diode, Infineon	D1, D101
30	3	FIDUCIAL	FIDUCIAL	ADJ_1, ADJ_2, ADJ_3
31	1	FTSH-105-01-F-D-K	Connector 2x5, Samtec	X5
32	1	IFX1117MEV33	Linear Voltage Regulator, Infineon	IC101
33	1	KSZ8031RNL	Ethernet Phy, Micrel	IC200
34	2	LED-GN/D/0603	LED green	LED100, LED101
35	2	LED-RT/D/0603	LED red	LED1, LED2
36	1	S25FL032P0XMF101	Quad-SPI Flash, Spansion	IC400

**Table 2 List of Material**

No.	Qty	Value	Device	Reference Designator
37	3	TMPS2-SMD	Push Button	SW1, SW2, SW3
38	1	7499010211A	Ethernet RJ45 Plug, Würth	X200
39	2	XMC4500-F100F1024	Microcontroller Cortex M4F, Infineon	IC1, IC100
40	2	ZX62-AB-5PA	Micro USB Plug	X3, X100
41	1	no ass.	Pin Header 1x4	X101
42	1	no ass./OR	Resistor	R206

[www.infineon.com](http://www.infineon.com)

Published by Infineon Technologies AG