

BTS3205G

One-Channel, Self-Protected, Low-Side Power Switch

THE BTS3205 is a monolithic, one-channel, self-protected, low-side switch in PG-DSO-8 package. In brief, it contains a N-channel MOSFET and the additional protection circuitry. The thermo shutdown with auto restart feature provides protection of the controlled loads.

The device provides protection against over-temperature, short-circuits, and over-voltage. Additionally its input pins are ESD protected.

Applications

- Relay drivers
- Small motors and solenoid driver
- Small loads protected switch
- Replaces electromechanical relays
- Replaces discrete circuit switches
- Protected, general purpose switching applications



Features

- Very low input quiescent current
- Short-circuit, over-voltage, over-temperature protection
- Input ESD protection
- Green-Robust and Automotive qualified

Benefits

- Saves PCB area
- Low input drive current
- EMC optimized switch

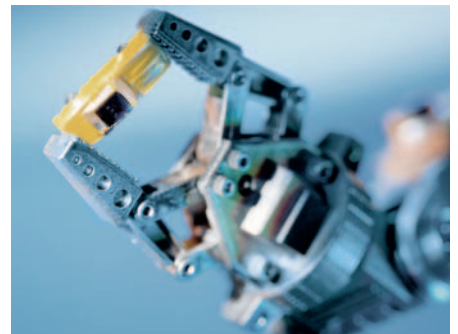

www.infineon.com/hitfet

Power Semiconductors



Never stop thinking

Block Diagram

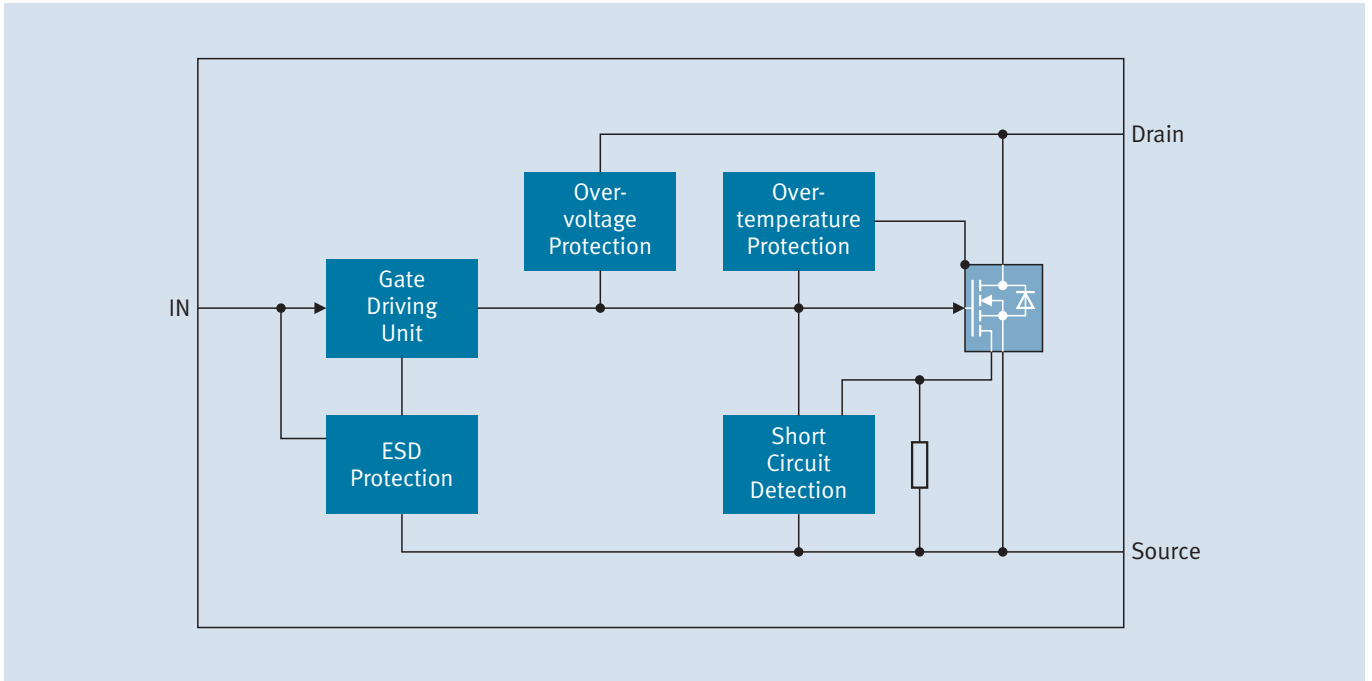

Application Example

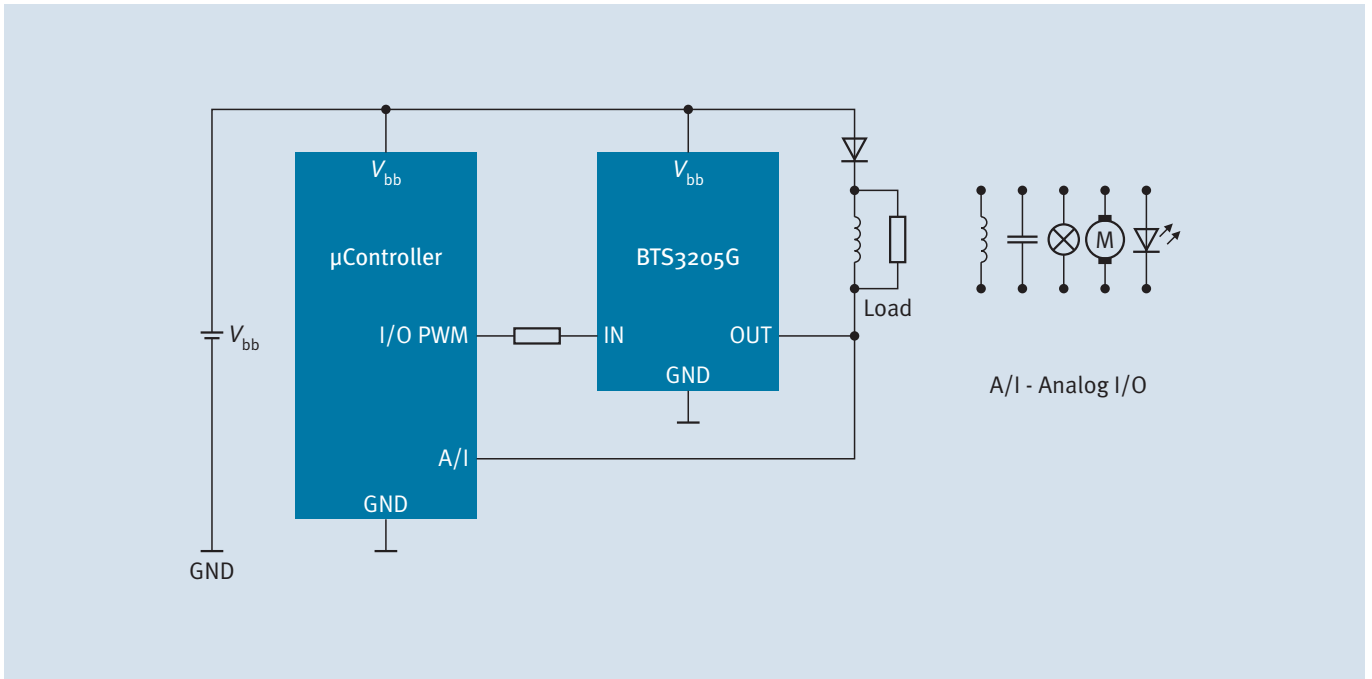

How to reach us:
<http://www.infineon.com>

Published by
 Infineon Technologies AG
 81726 Munich, Germany

© 2008 Infineon Technologies AG
 All Rights Reserved.

Legal Disclaimer

The information given in this Product Brief shall in no event be regarded as a guarantee of conditions or characteristics. With respect to any examples or hints given herein, any typical values stated herein and/or any information regarding the application of the device, Infineon Technologies hereby disclaims any and all warranties and liabilities of any kind, including without limitation, warranties of non-infringement of intellectual property rights of any third party.

Information

For further information on technology, delivery terms and conditions and prices, please contact the nearest Infineon Technologies Office (www.infineon.com).

Warnings

Due to technical requirements, components may contain dangerous substances. For information on the types in question, please contact the nearest Infineon Technologies Office.

Infineon Technologies components may be used in life-support devices or systems only with the express written approval of Infineon Technologies, if a failure of such components can reasonably be expected to cause the failure of that life-support device or system or to affect the safety or effectiveness of that device or system. Life support devices or systems are intended to be implanted in the human body or to support and/or maintain and sustain and/or protect human life. If they fail, it is reasonable to assume that the health of the user or other persons may be endangered.