

## BTM 7700G Trilith IC



THE BTM 7700G is part of the Trilith IC family containing three dies in one package: One double high-side switch and two low-side switches. The drains of these three vertical DMOS chips are mounted on separated lead frames. The sources are connected to individual pins, so the BTM 7700G can be used in H-bridge- as well as in any other configuration. The double high-side switch is manufactured in SMART SIPMOS® technology which combines low  $R_{DSon}$  vertical DMOS power stages with CMOS circuitry for control, protection and diagnosis. To achieve low  $R_{DSon}$  and fast switching performance, the low-side switches are manufactured in S-FET logic level technology.

### Product Summary

Type	Package	Marking
BTM 7700G	PG-DSO-28-22	BTM 7700G

### Applications

- Door lock
- Fuel flap lock
- Mirror flap
- Steering wheel lock
- Headrest adjustment
- Various industry applications

### Features

- Quad D-MOS switch driver
- Free configurable as bridge or quad-switch
- Optimized for DC motor management applications
- Low  $R_{DSon}$   
High side: 110 mΩ typ. @ 25°C, 280 mΩ max. @ 150°C  
Low side: 80 mΩ typ. @ 25°C, 200 mΩ max. @ 150°C
- Peak current: typ. 9.5 A @ 25°C
- Very low quiescent current: typ. 5 μA @ 25°C
- Small outline, enhanced power PG-DSO-package
- Operates up to 40 V
- PWM frequencies up to 1 kHz
- Load and GND-short-circuit-protection
- Overtemperature shut down with hysteresis
- Undervoltage detection with hysteresis
- Status flag diagnosis
- Internal clamp diodes
- Isolated sources for external current sensing
- Green product (RoHS compliant)
- AEC qualified

[www.infineon.com/trilithic](http://www.infineon.com/trilithic)

## Automotive Power



Never stop thinking

## Block Diagram

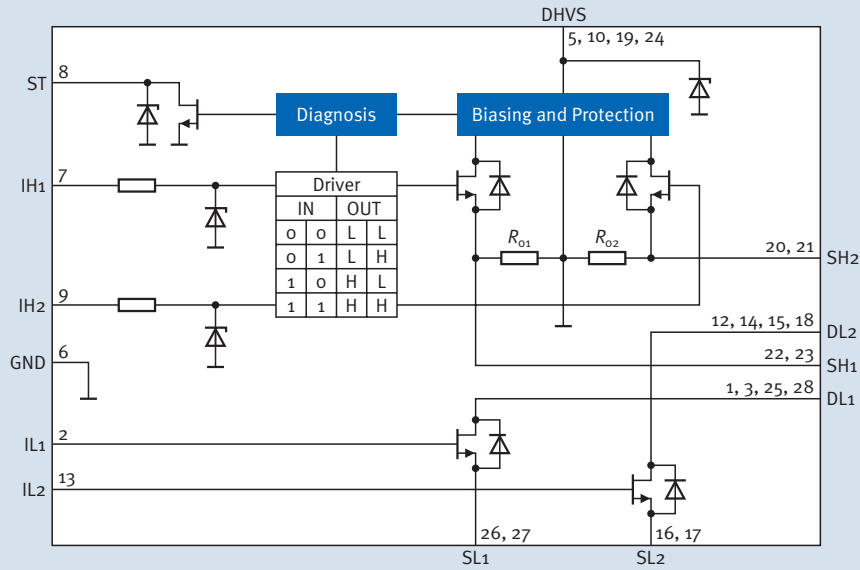

## Application Example

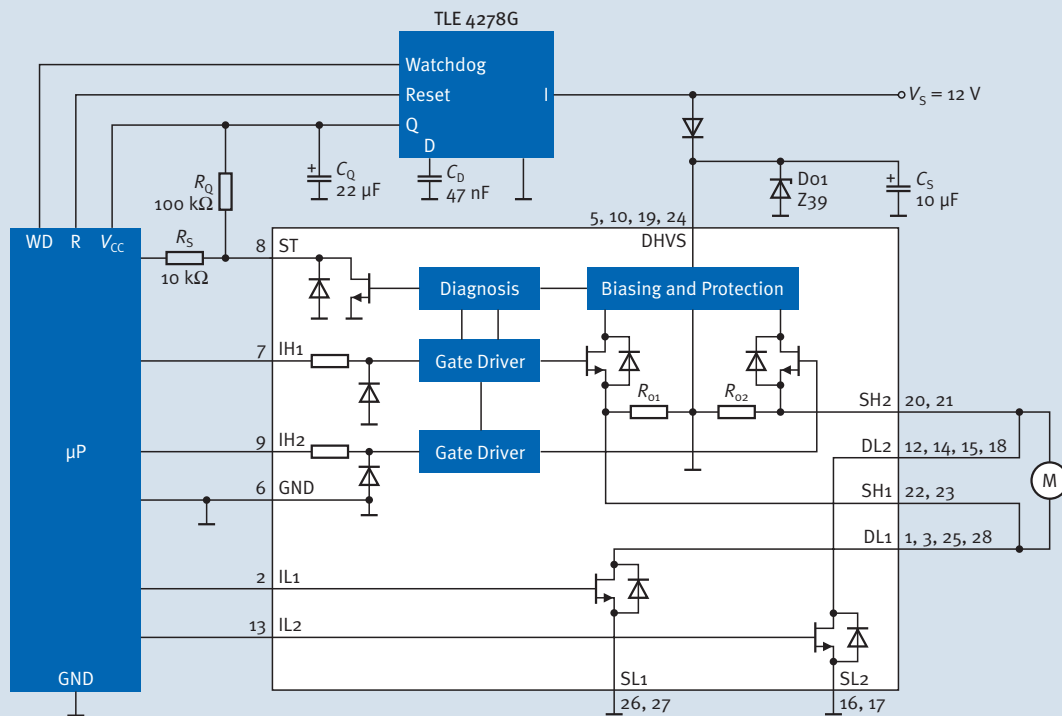

How to reach us:  
<http://www.infineon.com>

Published by  
**Infineon Technologies AG**  
 81726 Munich, Germany

© 2007 Infineon Technologies AG  
 All Rights Reserved.

### Legal Disclaimer

The information given in this Product Brief shall in no event be regarded as a guarantee of conditions or characteristics. With respect to any examples or hints given herein, any typical values stated herein and/or any information regarding the application of the device, Infineon Technologies hereby disclaims any and all warranties and liabilities of any kind, including without limitation, warranties of non-infringement of intellectual property rights of any third party.

### Information

For further information on technology, delivery terms and conditions and prices, please contact the nearest Infineon Technologies Office ([www.infineon.com](http://www.infineon.com)).

### Warnings

Due to technical requirements, components may contain dangerous substances. For information on the types in question, please contact the nearest Infineon Technologies Office.

Infineon Technologies components may be used in life-support devices or systems only with the express written approval of Infineon Technologies, if a failure of such components can reasonably be expected to cause the failure of that life-support device or system or to affect the safety or effectiveness of that device or system. Life support devices or systems are intended to be implanted in the human body or to support and/or maintain and sustain and/or protect human life. If they fail, it is reasonable to assume that the health of the user or other persons may be endangered.