



Speed PROFET™ – BTF 50060-1TEA Motor Drive High Side Switch

THE BTF 50060-1TEA IS A SINGLE CHANNEL 6mΩ (max. 12mΩ @ 150°C) High Side Driver, able to be driven by PWM control signals with high frequencies, such as 25kHz, but also capable of DC operation.

The device is housed in PG-T0252-5 (DPAK 5 pin) RoHS compliant package. In combination with a freewheeling diode, the BTF50060-1TEA can be set up in a half bridge topology.

The device includes protection functions like short circuit and overtemperature shutdown. Through the IS pin, BTF 50060-1TEA provides an accurate load current measurement in normal operation and a diagnostic feedback, with a defined signal, for such events as open load – both in ON and OFF state, overcurrent and overtemperature.

The Speed PROFET™ doesn't need an external bootstrap capacitor for high frequency switching.

Applications

- Most suitable for driving motors, valves, and coils, e.g. fuel pump
- Capable of PWM switching frequency of 25kHz and above

Key Features

- PWM capability of more than 25kHz
- 6mΩ R_{ON} (max. 12mΩ @ 150°C) with high inrush current
- No external bootstrap capacitor necessary
- 3.3V and 5V compatible logic inputs
- Advanced analog load current sense signal
- Overload and overtemperature protection, with defined diagnostic signal

Key Benefits

- Reduced power dissipation
- Small package for high current motor drive, less PCB space
- Reduced component count and easier PCB layout
- Direct connection to the MCU
- Easy current sense calibration



Speed PROFET™ – BTF 50060-1TEA

Motor Drive High Side Switch

Block Diagram

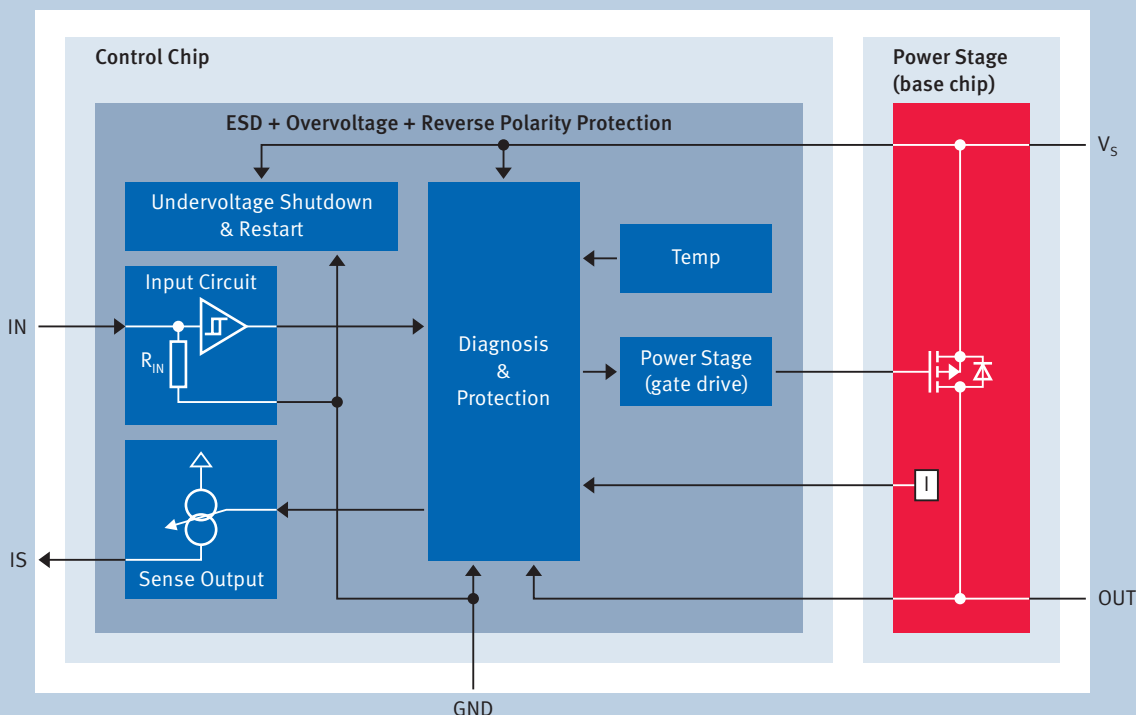

Application Example

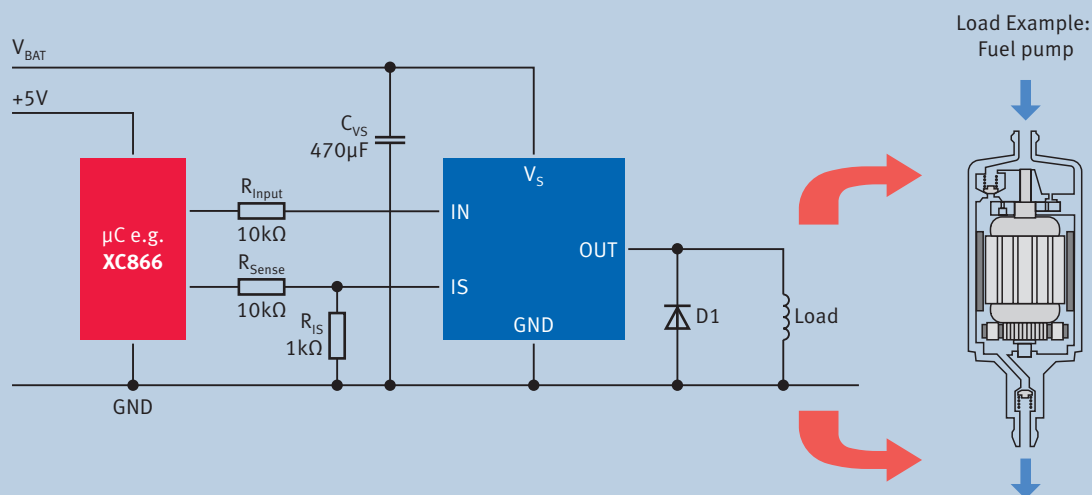

How to reach us:
<http://www.infineon.com>

Published by
 Infineon Technologies AG
 81726 Munich, Germany

© 2010 Infineon Technologies AG
 All Rights Reserved.

Legal Disclaimer The information given in this Product Brief shall in no event be regarded as a guarantee of conditions or characteristics. With respect to any examples or hints given herein, any typical values stated herein and/or any information regarding the application of the device, Infineon Technologies hereby disclaims any and all warranties and liabilities of any kind, including without limitation, warranties of non-infringement of intellectual property rights of any third party.

Information For further information on technology, delivery terms and conditions and prices, please contact the nearest Infineon Technologies Office (www.infineon.com).

Warnings Due to technical requirements, components may contain dangerous substances. For information on the types in question, please contact the nearest Infineon Technologies Office. Infineon Technologies components may be used in life-support devices or systems only with the express written approval of Infineon Technologies, if a failure of such components can reasonably be expected to cause the failure of that life-support device or system or to affect the safety or effectiveness of that device or system. Life support devices or systems are intended to be implanted in the human body or to support and/or maintain and sustain and/or protect human life. If they fail, it is reasonable to assume that the health of the user or other persons may be endangered.