

PROFET™+ Smart High-Side Power Switches



THE PROFET™+ Family are single and dual channel protected high-side power switches (180 mΩ to 20 mΩ) in the PG-DSO-8 and PG-DSO-14 exposed pad packages. They provide state of the art diagnostics and protection features. Their high short circuit robustness combined with switching load capability is benchmark in the market.

The devices are especially designed to drive lamps from 1 *5W up to 2 * 27W +5W per channel as well as LEDs in the harsh automotive environment. These are the first and second wave of Infineon's new PROFET™+ family - a portfolio of single & dual channel smart high side switches.

PROFET™+ offers 100% pin compatibility across devices in the PG-DSO-8 exposed pad package as well as devices in the PG-DSO-14 exposed pad package. PROFET™+ devices in the PG-DSO-8 package can also share the layout of the PROFET™+ devices using the PG-DSO-14 package. Based on this compatible footprint, maximum design flexibility is given to change loads and devices without major modification of the board layout.

Applications:

- 12V grounded high-side loads up to 5A DC (permanent/channel)
- Suitable for automotive and industrial applications
- Capacitive loads such as lamps
- Inductive loads such as relays and solenoids
- Resistive loads such as heater elements
- Replaces electromechanical relays, fuses and discrete circuits

www.infineon.com/profet

Key Features

- N-channel MOSFET with charge pump
- Very low stand-by current (<0.5μA)
- PWM capability up to 200Hz (up to 400Hz for LEDs)
- AEC Qualified, ROHS and ELV compliant
- Analog current sense combined with digital fault feedback
- ESD, overvoltage, overload and overtemperature protected
- Current limitation and short circuit protection
- Open load detection and diagnosis in ON and OFF state

Key Benefits

- Best-in-class current sense accuracy
- Ultra low quiescent current - a new industry benchmark
- Enable/disable multiplexed current sense outputs - minimizes demand for A/D ports
- Short circuit robustness specified in the product datasheets
- Easy to design in - broad flexible portfolio, sharing the same features set across all PROFET™+ devices
- If you know one PROFET™+ device, you know them all!

PROFET™+ Smart High-Side Power Switches

Block Diagram (dual-channel device)

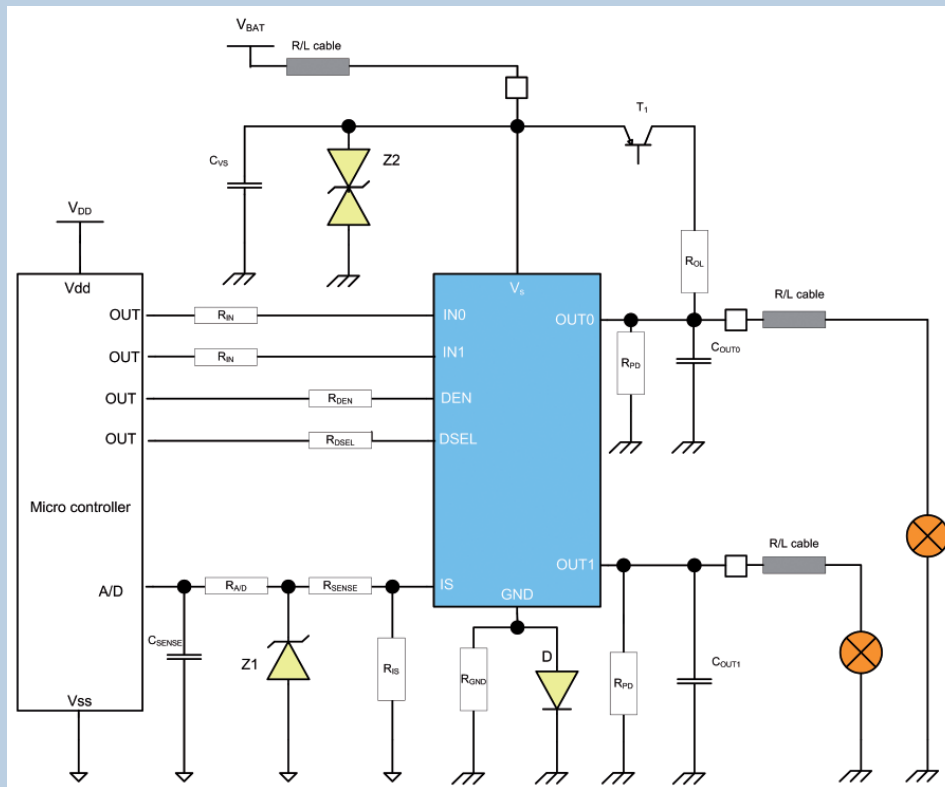

Product Summary

Part Number	Package	Green	Channel	$R_{ON@TJ=25^{\circ}C}$ [mΩ]	Operating Voltage Range [V]	IL (SC) (min) [A]	Diagnostic
BTS 5020-2EKA	PG-DSO-14	Yes	2	20	5.0 - 28.0	50	Sense
BTS 5030-1EJA	PG-DSO-8	Yes	1	30	5.0 - 28.0	36	Sense
BTS 5030-2EKA	PG-DSO-14	Yes	2	30	5.0 - 28.0	36	Sense
BTS 5045-1EJA	PG-DSO-8	Yes	1	45	5.0 - 28.0	25	Sense
BTS 5045-2EKA	PG-DSO-14	Yes	2	45	5.0 - 28.0	25	Sense
BTS 5090-1EJA	PG-DSO-8	Yes	1	90	5.0 - 28.0	20	Sense
BTS 5090-2EKA	PG-DSO-14	Yes	2	90	5.0 - 28.0	20	Sense
BTS 5120-2EKA	PG-DSO-14	Yes	2	120	5.0 - 28.0	9	Sense
BTS 5180-2EKA	PG-DSO-14	Yes	2	180	5.0 - 28.0	8	Sense

Published by
Infineon Technologies AG
85579 Neubiberg, Germany

© 2011 Infineon Technologies AG.
All Rights Reserved.

Visit us:
www.infineon.com

Order Number: B127-H9531-G1-X-7600
Date: 09 / 2011

ATTENTION PLEASE!

The information given in this document shall in no event be regarded as a guarantee of conditions or characteristics ("Beschaffheitsgarantie"). With respect to any examples or hints given herein, any typical values stated herein and/or any information regarding the application of the device, Infineon Technologies hereby disclaims any and all warranties and liabilities of any kind, including without limitation warranties of non-infringement of intellectual property rights of any third party.

INFORMATION

For further information on technology, delivery terms and conditions and prices please contact your nearest Infineon Technologies Office (www.infineon.com).

WARNINGS

Due to technical requirements components may contain dangerous substances. For information on the types in question please contact your nearest Infineon Technologies Office. Infineon Technologies Components may only be used in life-support devices or systems with the express written approval of Infineon Technologies, if a failure of such components can reasonably be expected to cause the failure of that life-support device or system, or to affect the safety or effectiveness of that device or system. Life support devices or systems are intended to be implanted in the human body, or to support and/or maintain and sustain and/or protect human life. If they fail, it is reasonable to assume that the health of the user or other persons may be endangered.