

AP1676

**Sensorless Regulation of a  
Brushless DC Motor with a  
C164CM ( Voltage Detection Mode )**

Authors: R. Weiss & T. Kattwinkel

16 – Bit CMOS Microcontroller Product

Microcontrollers



Never stop thinking.

## Revision History

Revision	Modifications	Date	Modified by

**Edition 2001-07**

**Published by  
Infineon Technologies AG  
81726 München, Germany**

**© Infineon Technologies AG 2006.  
All Rights Reserved.**

#### **LEGAL DISCLAIMER**

THE INFORMATION GIVEN IN THIS APPLICATION NOTE IS GIVEN AS A HINT FOR THE IMPLEMENTATION OF THE INFINEON TECHNOLOGIES COMPONENT ONLY AND SHALL NOT BE REGARDED AS ANY DESCRIPTION OR WARRANTY OF A CERTAIN FUNCTIONALITY, CONDITION OR QUALITY OF THE INFINEON TECHNOLOGIES COMPONENT. THE RECIPIENT OF THIS APPLICATION NOTE MUST VERIFY ANY FUNCTION DESCRIBED HEREIN IN THE REAL APPLICATION. INFINEON TECHNOLOGIES HEREBY DISCLAIMS ANY AND ALL WARRANTIES AND LIABILITIES OF ANY KIND (INCLUDING WITHOUT LIMITATION WARRANTIES OF NON-INFRINGEMENT OF INTELLECTUAL PROPERTY RIGHTS OF ANY THIRD PARTY) WITH RESPECT TO ANY AND ALL INFORMATION GIVEN IN THIS APPLICATION NOTE.

#### **Information**

For further information on technology, delivery terms and conditions and prices please contact your nearest Infineon Technologies Office ([www.infineon.com](http://www.infineon.com)).

#### **Warnings**

Due to technical requirements components may contain dangerous substances. For information on the types in question please contact your nearest Infineon Technologies Office.

Infineon Technologies Components may only be used in life-support devices or systems with the express written approval of Infineon Technologies, if a failure of such components can reasonably be expected to cause the failure of that life-support device or system, or to affect the safety or effectiveness of that device or system. Life support devices or systems are intended to be implanted in the human body, or to support and/or maintain and sustain and/or protect human life. If they fail, it is reasonable to assume that the health of the user or other persons may be endangered.

# Contents

<b>1</b>	<b>INTRODUCTION.....</b>	<b>5</b>
1.1	WHY USE BRUSHLESS DC MOTORS (ADVANTAGES/DISADVANTAGES)?.....	5
1.2	FUNCTIONAL PRINCIPLE OF A BRUSHLESS DC MOTOR.....	5
1.3	BRUSHLESS DC MOTOR WITH HALL SENSORS.....	6
1.4	BRUSHLESS DC MOTOR WITHOUT HALL SENSORS.....	6
<b>2</b>	<b>OPERATION OF A BRUSHLESS DC MOTOR.....</b>	<b>8</b>
2.1	VISUALIZATION OF THE ROTATION INCLUDING APPROPRIATE SWITCHES OF A 3-PHASE BRUSHLESS DC MOTOR (0° MECHANICAL TO 180° MECHANICAL).....	8
2.1.1	<i>Position ‘ 0° ’</i> .....	9
2.1.2	<i>Position ‘ 30° ’</i> .....	10
2.1.3	<i>Position ‘ 60° ’</i> .....	11
2.1.4	<i>Position ‘ 90° ’</i> .....	12
2.1.5	<i>Position ‘ 120° ’</i> .....	13
2.1.6	<i>Position ‘ 150° ’</i> .....	14
2.1.7	<i>Position ‘ 180° ’</i> .....	15
2.2	SENSORS.....	16
2.2.1	<i>Hall sensor output signal</i> .....	16
2.3	SYSTEM DESCRIPTION.....	16
2.3.1	<i>Block diagram of block commutation using Hall sensors</i> .....	16
2.3.2	<i>Block diagram of block commutation without sensors</i> .....	17
<b>3</b>	<b>BLOCK COMMUTATION MODE WITH BACK-EMF DETECTION.....</b>	<b>19</b>
3.1	GENERAL.....	19
3.1.1	<i>Back-EMF sensing</i> .....	19
3.2	REQUIRED PERIPHERALS.....	22
3.2.1	<i>CAPCOM6</i> .....	22
3.2.2	<i>ADC</i> .....	23
<b>4</b>	<b>IMPLEMENTATION.....</b>	<b>24</b>

4.1	FUNCTIONAL DESCRIPTION .....	24
4.1.1	General description .....	24
4.1.2	Management of commutation, demagnetization and zero cross detection.....	25
4.2	IMPLEMENTATION OF THE SOFTWARE .....	25
4.2.1	Initialization.....	25
4.2.2	State machine.....	26
4.2.3	Interrupt routines .....	26
4.3	PERFORMANCE ANALYSIS.....	28
4.3.1	Hardware requirements .....	28
4.3.2	CPU load.....	28
5	CONCLUSION.....	30
6	ABBREVIATIONS .....	31

# 1 Introduction

## 1.1 Why use brushless DC motors (advantages/disadvantages)?

Brushless DC motors are synchronous motors suitable for use as a simple means of controlling permanent drives (e.g. ABS pumps, EHPS pumps, fuel pumps or cooling fans). This type of 3-, 4- or 5-phase brushless DC motor will increasingly replace brushed DC motors. Brushed DC motors require maintenance, e.g. to service coal brushes and commutator. Another major problem with a brushed DC machine is the possibility of brush burnout in the event of an overload or stall condition.

One of the main advantages of brushless DC motors is their robustness against obsolescence (due to the absence of brushes), and another major benefit is the high efficiency and high torque of a brushless DC motor.

A disadvantage of this type of motor is that the rotor position is usually determined by three Hall sensors (in the case of three phases), which are expensive and require signal conditioning, and this positioning in the production process has to be done very precisely to assure proper operation.

## 1.2 Functional principle of a brushless DC motor

Figure 1 shows a three-phase brushless DC motor with two pole pairs. The rotation of the electrical field (vector) has to be applied twice as fast as the desired mechanical speed of the brushless DC motor. The three coils of the stator are split into two groups of coils (A, B, C and A', B', C'). As you can see in Figure 1, coils A and C are energized and coil B is not energized. A 0° to 180° rotation will be shown in detail in section 2.1 to explain the setting of the appropriate switches of the B6 bridge pattern, the appropriate voltages relating to the coils, and the energized coils of the motor with the suitable rotor position between 0° and 180° mechanical.

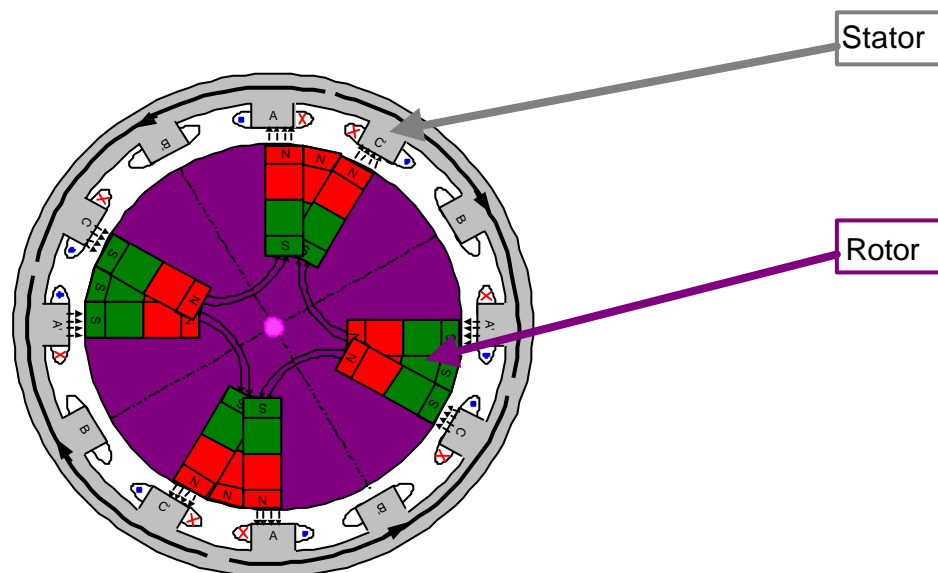

Figure 1: Functional principle of a brushless DC motor

### 1.3 Brushless DC motor with Hall sensors

A synchronous motor mainly depends on synchronous processes, e.g. ADC measurement has to be absolutely synchronous with the energizing pattern of the coils realized by the switches of the B6 bridge. In this context, the change of state of the three Hall sensors gives an indication of the specific time at which the next pattern of the B6 full-bridge has to be applied. Each of these Hall sensors costs about \$0.15 - \$0.30, so they have a big impact on the total cost of the whole application. Typically, external hardware is needed, such as three comparators for sensor signal conditioning.

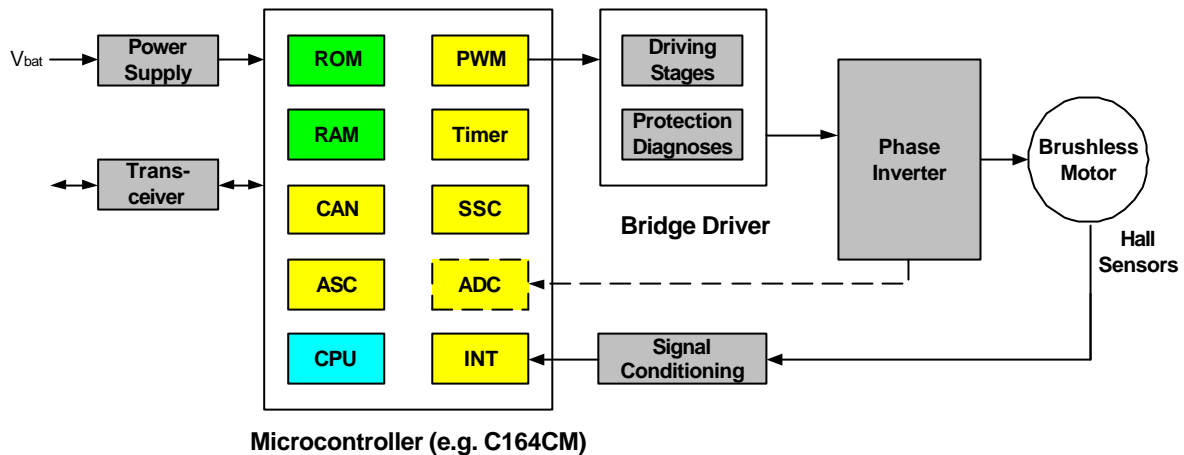
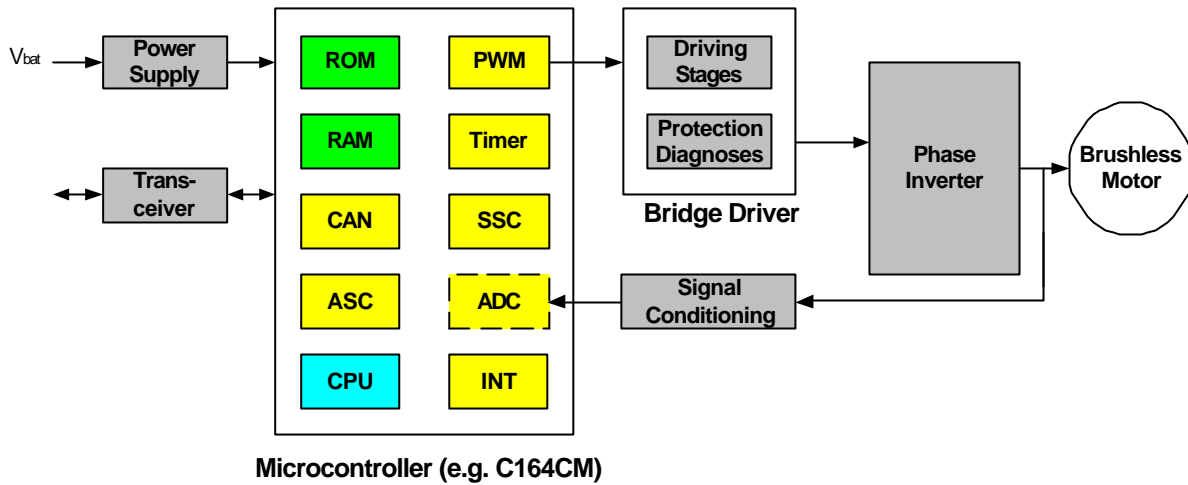

Figure 2: General block diagram for brushless DC motor drive with sensors

### 1.4 Brushless DC motor without Hall sensors

The aim of this application note is to eliminate position sensors altogether. The C164CM 16-bit  $\mu$ C in its small P-TQFP 64 package (12\*12 mm incl. pins) fits this type of application very well because of its flexible capture compare unit (CAPCOM6), with two 16-bit timers and 6 + 1 output channels. Many other features are listed at the end of the application. Three channels of the 10-bit ADC of the C164CM and only a two-resistor voltage divider with a capacitor at each of the three phases are the hardware necessary to realize a viable sensorless brushless DC motor. The most important point – and at the same time a big advantage of this hardware configuration – is the aspect of minimized costs, because even the comparators that would normally be necessary are superfluous. A 16-bit microcontroller delivering high CPU performance, with a fast and accurate 10-bit ADC, has a big advantage at higher speeds up to 5000 rpm because of the very acceptable CPU load even in these conditions. A very important point in relation to the cost-effective back-EMF sensing is the very low leakage current of the C164CM ADC (+/- 200 nA), because the back-EMF is low at low speeds and the use of a high-impedance voltage divider is necessary.



**Figure 3: General block diagram for sensorless BLDC motor drive**

When a brushless DC motor is energized in block commutation mode, only two of the three phases are active at a given time. The brushless DC motor rotor position has to be evaluated by the zero crossing of the back-EMF which can be evaluated by measuring the non-energized phase. The voltage value of the back-EMF has to be half of the maximum value to detect the precise point for changing the coil-energizing pattern for the following 30° mechanical rotation. It is very important to find the precise point for the next change in the energizing pattern to ensure smooth operation of this type of motor. A big advantage in this context is the fact that the back-EMF is proportional to the mechanical rotation speed. This means that we are able to use the measured C164CM 10-bit ADC values directly without any type of linearization algorithm. This allows the use of very fast regulation software, because the mechanical speed of some applications should reach up to 6000 rpm. The amount of back-EMF is a function of the number of coil windings, mechanical speed, and flux ( $E = N \times \phi \times n$ ). Taking account of a low rotation speed, it is very important to have a high resolution with regard to the ADC microcontroller (10-bit +/- 2 LSB minimum) to evaluate the back-EMF with the application necessary demand. The 16-bit broad code and data core and the 16\*16 or 32 / 16-bit multiply-accumulate as part of the C164CM instruction set e.g. allows fast processing of the 16-bit integer or even float PI speed regulator because of the multiplications (6) and divisions (3) which are necessary in this case.



## 2 Operation of a brushless DC motor

### 2.1 *Visualization of the rotation including appropriate switches of a 3-phase brushless DC motor (0° mechanical to 180° mechanical)*

Only two of the three phases are energized in each state of the B6 full-bridge. The non-energized phase can therefore be used to detect the zero crossing of the back-EMF as explained later (cf. the black arrow in the voltage diagram shown in Figures 5, 7, 9, 11, 13, 15, 17). The following explanation will show you the turning of a two pole-pair brushless DC motor as a function of the state of the appropriate switches shown in Figures 4, 6, 8, 10, 12, 14, 16. In fact, driving a two pole-pair motor means that the rotation speed of the electrical field has to be double the speed of the desired mechanical rotation speed  $\Omega = \omega / p$ , where  $\Omega$  is the mechanical rotation speed,  $\omega$  the rotation frequency of the electrical field and  $p$  is the number of pole pairs).

2.1.1 Position '0°'

Figure 5 shows the voltage-energizing coils C and A (stator) and the permanent magnet realized with two pole pairs (rotor), as well as indicating the zero-crossing detection coil B. Figure 4 shows the active switches of the B6 bridge, and Figure 5 again the appropriate rotor position (0°):

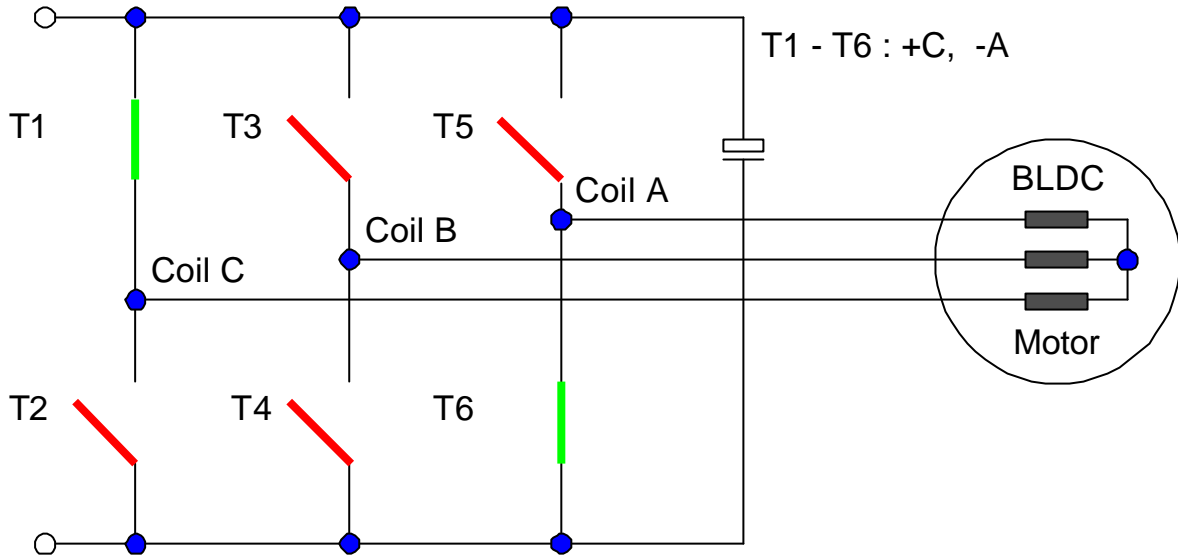

Figure 4: Appropriate switches T1, T6 of the B6 full-bridge ( coil C : pos., coil A : neg. )

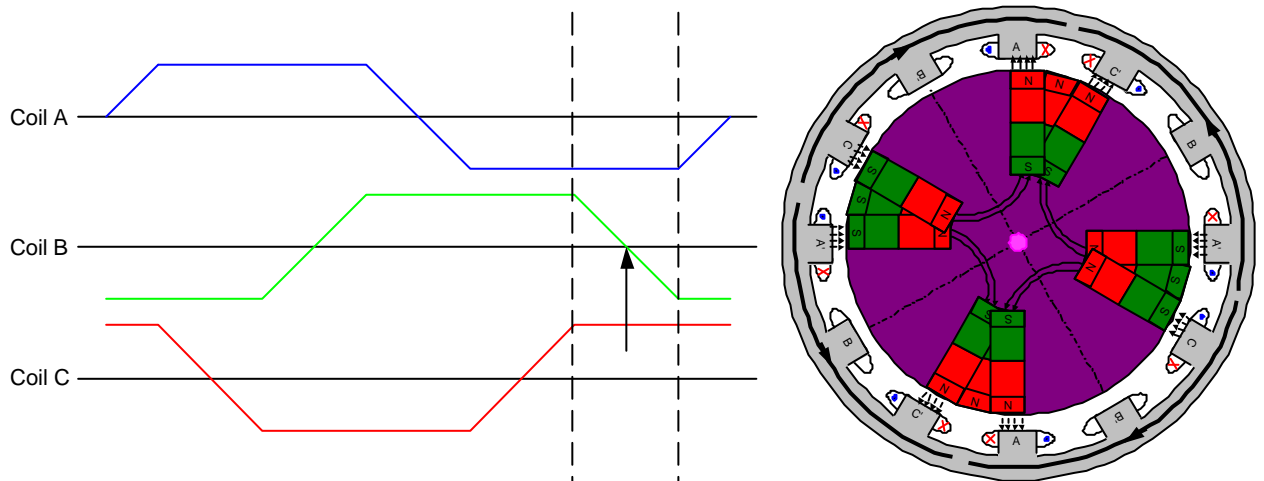

Figure 5: Energized coils C and A of a 2 pole-pair BLDC motor ( mechanical position : 0° )

2.1.2 Position ' 30° '

Figure 7 shows the voltage-energizing coils C and B (stator) and the permanent magnet realized with two pole pairs (rotor), as well as indicating the zero-crossing detection coil A. Figure 6 shows the active switches of the B6 bridge, and Figure 7 again the appropriate rotor position (30°):

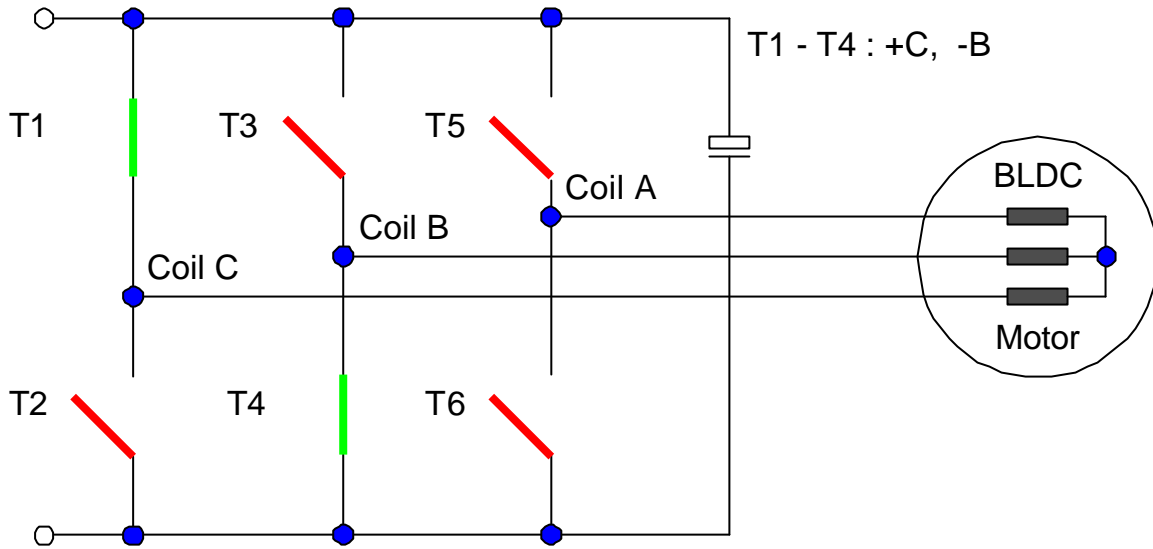

Figure 6: Appropriate switches T1, T4 of the B6 full-bridge ( coil C : pos., coil B : neg. )

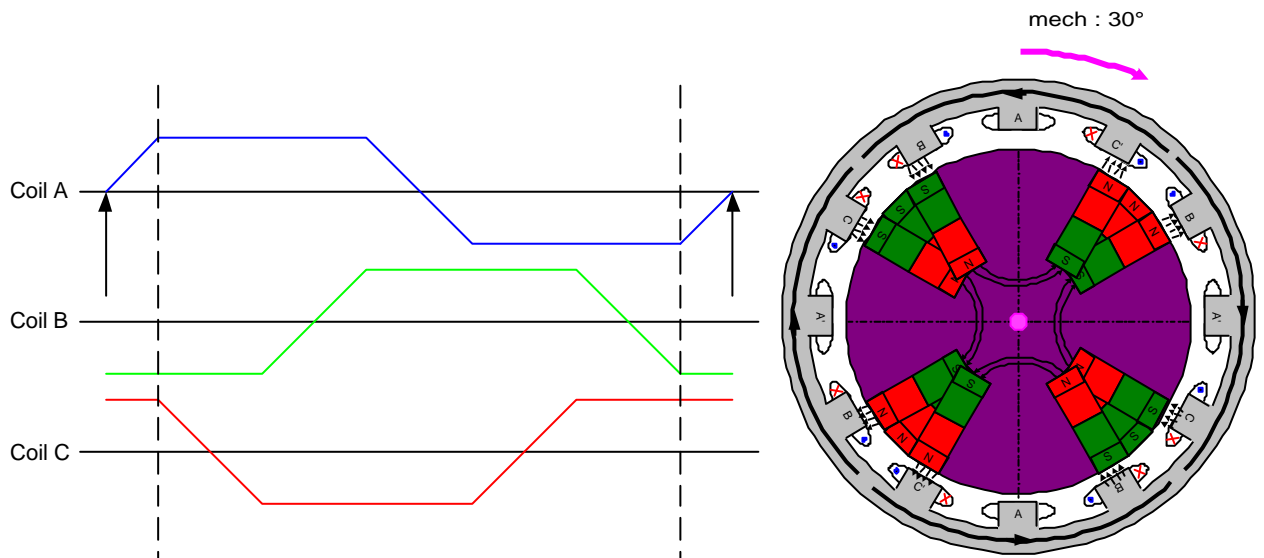

Figure 7: Energized coils C and B of a 2 pole-pair BLDC motor ( mechanical position : 30° )

2.1.3 Position ' 60° '

Figure 9 shows the voltage-energizing coils C and B (stator) and the permanent magnet realized with two pole pairs (rotor), as well as indicating the zero-crossing detection coil C. Figure 8 shows the active switches of the B6 bridge, and Figure 9 again the appropriate rotor position (60°):

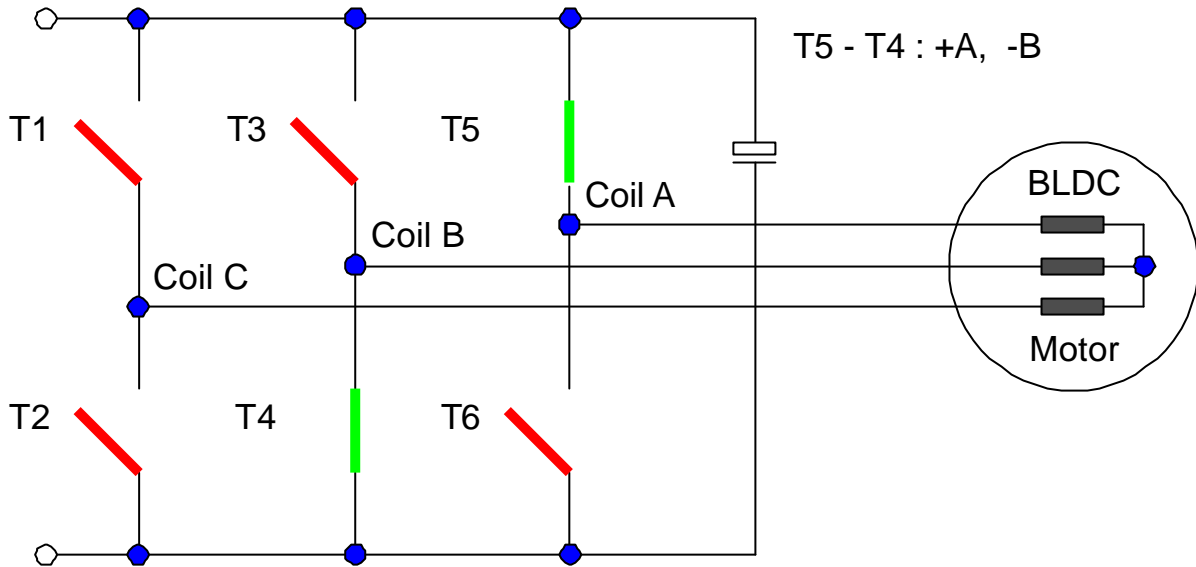

Figure 8: Appropriate switches T4, T5 of the B6 full-bridge ( coil A : pos., coil B : neg. )

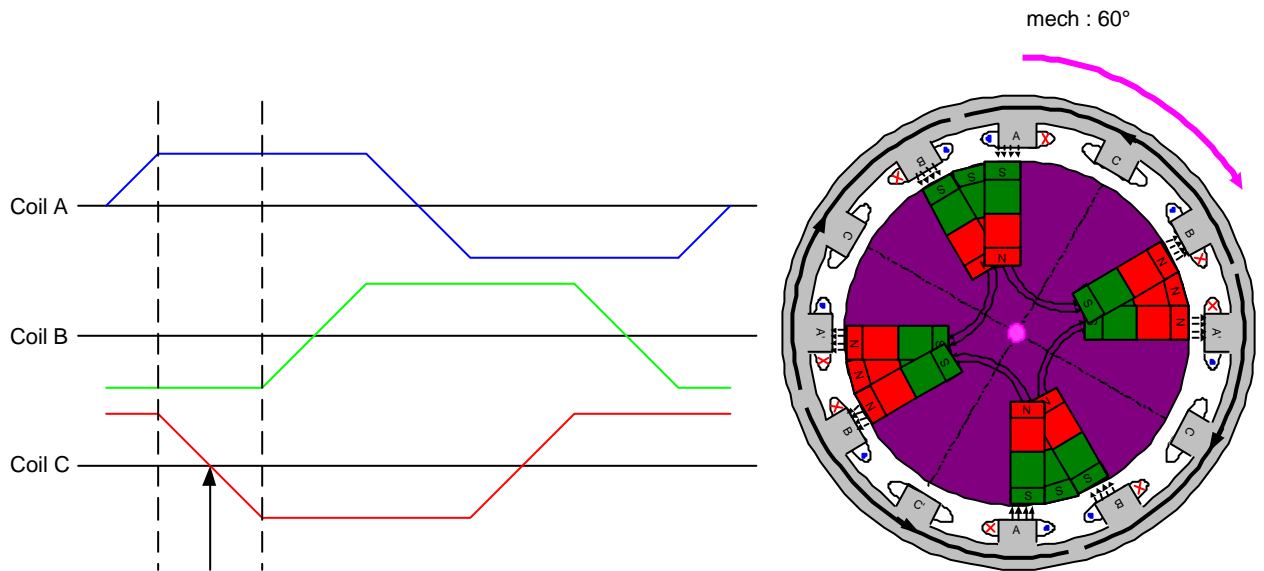

Figure 9: Energized coils A and B of a 2 pole-pair BLDC motor ( mechanical position : 60° )

2.1.4 Position ' 90° '

Figure 11 shows the voltage-energizing coils A and C (stator) and the permanent magnet realized with two pole pairs (rotor), as well as indicating the zero-crossing detection coil B. Figure 10 shows the active switches of the B6 bridge, and Figure 11 again the appropriate rotor position (90°):

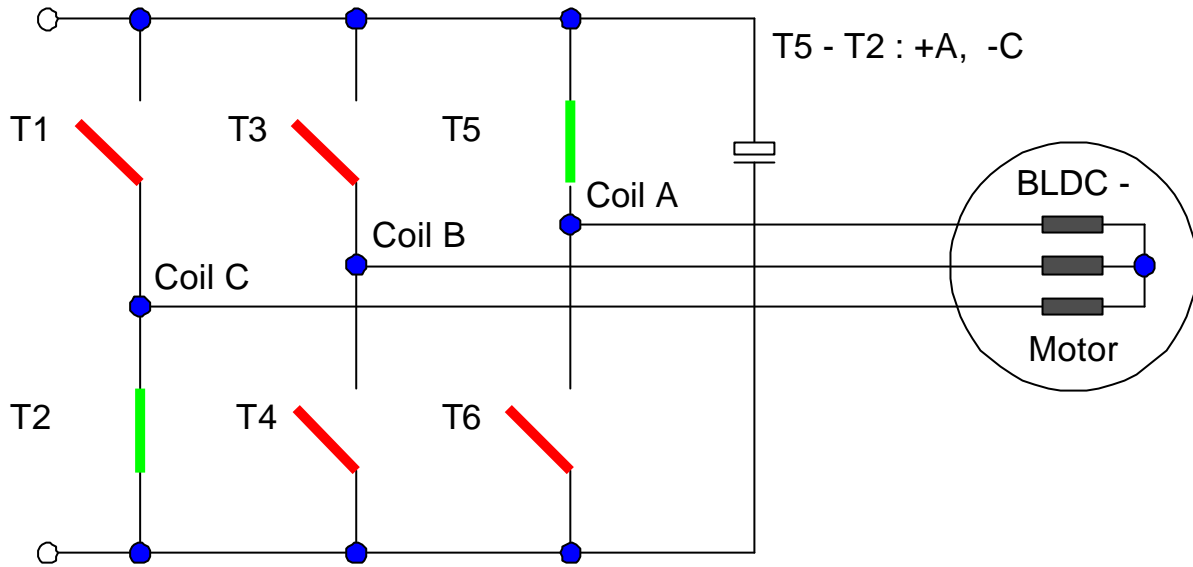

Figure 10: Appropriate switches T2, T5 of the B6 full-bridge ( coil A : pos., coil C : neg. )

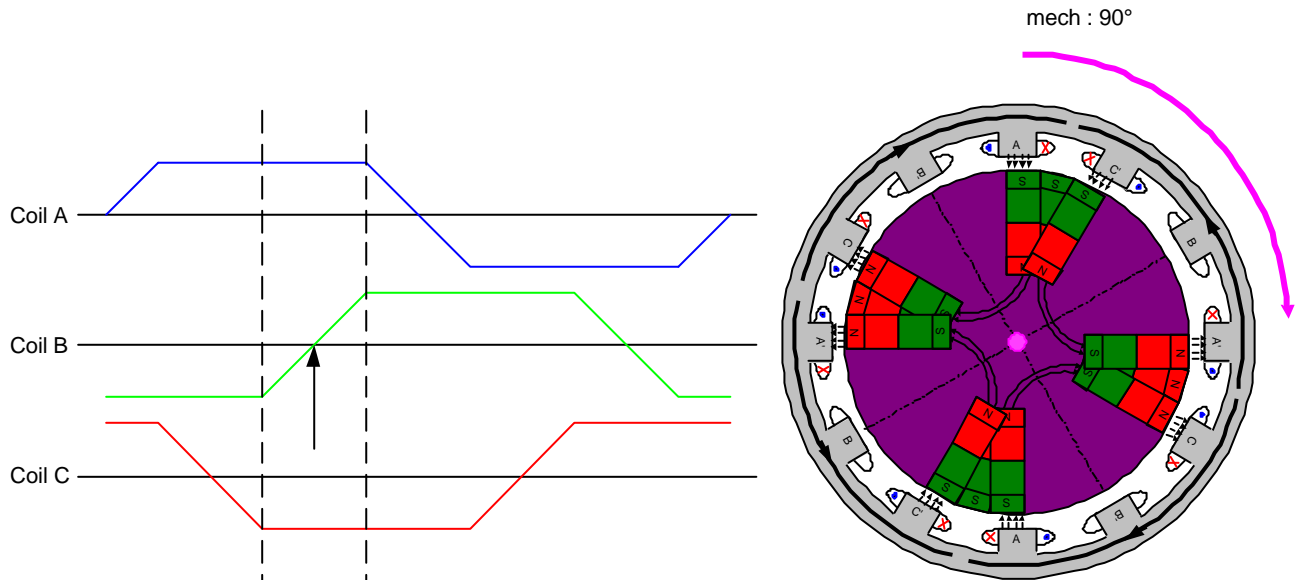

Figure 11: Energized coils A and C of a 2 pole-pair BLDC motor ( mechanical position : 90° )

2.1.5 Position ' 120° '

Figure 13 shows the voltage-energizing coils B and C (stator) and the permanent magnet realized with two pole pairs (rotor), as well as indicating the zero-crossing detection coil A. Figure 12 shows the active switches of the B6 bridge, and Figure 13 again the appropriate rotor position (120°):

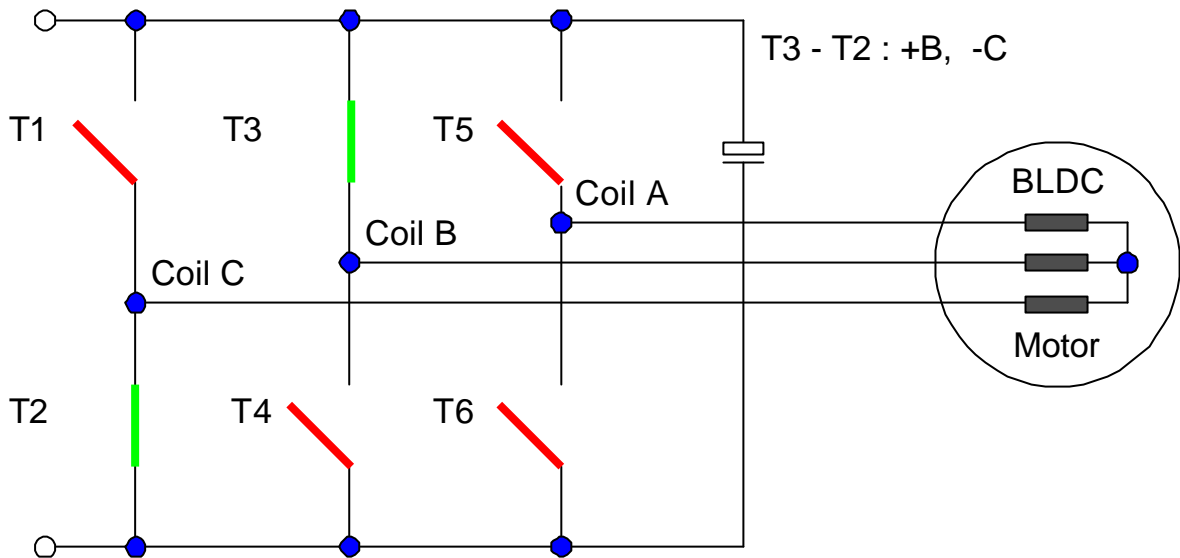

Figure 12: Appropriate switches T2, T3 of the B6 full-bridge ( coil B : pos., coil C : neg. )

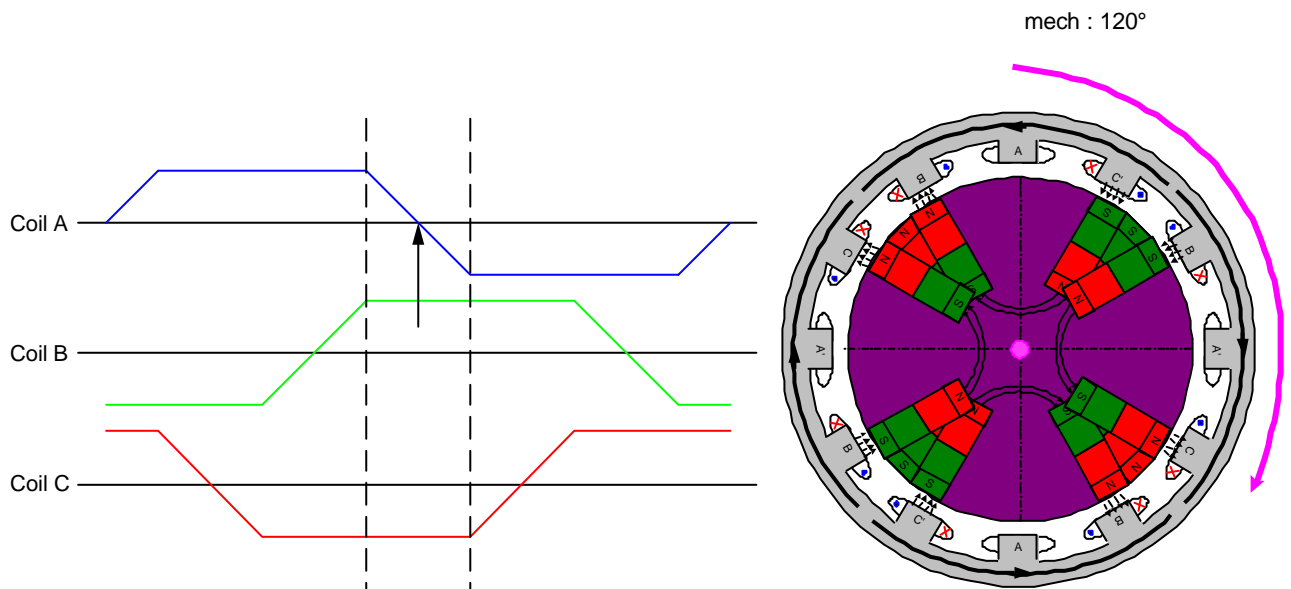

Figure 13: Energized coils B and C of a 2 pole-pair BLDC motor ( mechanical position : 120° )

2.1.6 Position ' 150° '

Figure 15 shows the voltage-energizing coils B and A (stator) and the permanent magnet realized with two pole pairs (rotor), as well as indicating the zero-crossing detection coil C. Figure 14 shows the active switches of the B6 bridge, and Figure 15 again the appropriate rotor position (150°):

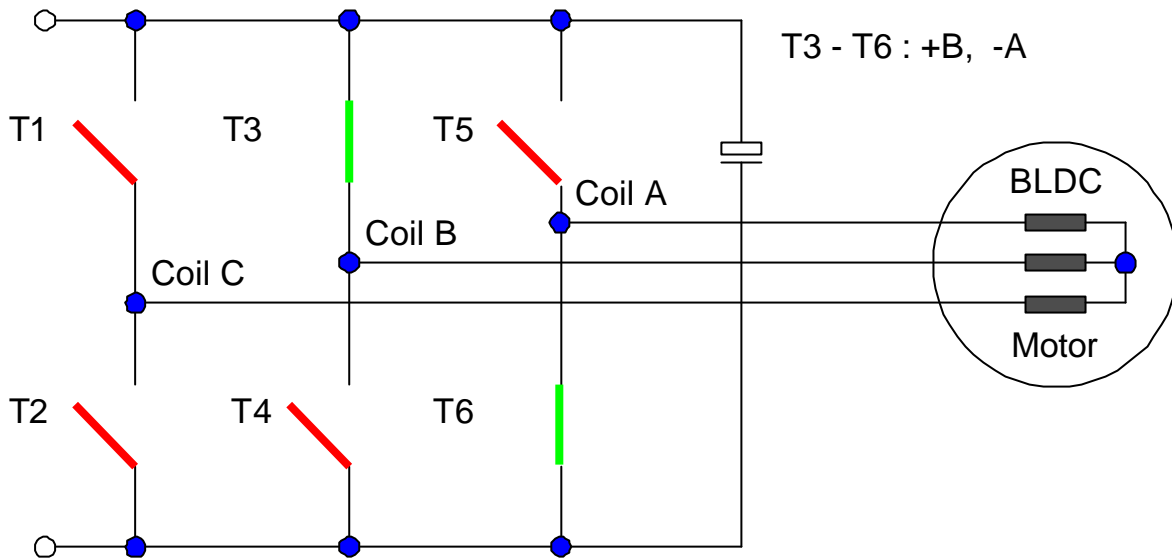

Figure 14: Appropriate switches T3, T6 of the B6 full-bridge ( coil B : pos., coil A : neg. )

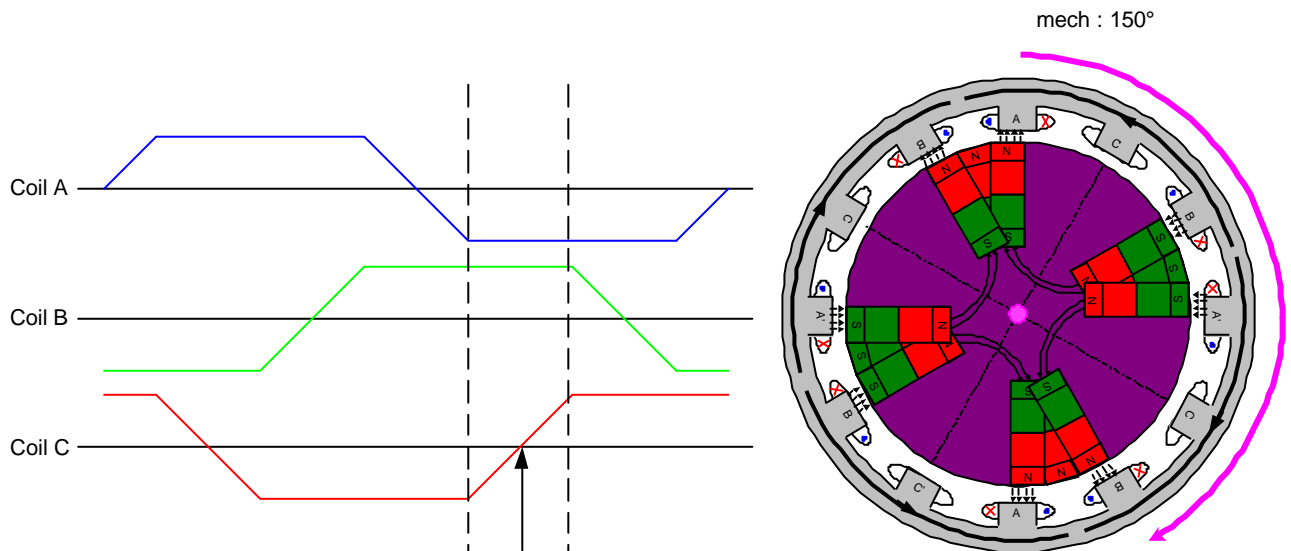

Figure 15: Energized coils A and C of a 2 pole-pair BLDC motor ( mechanical position : 150° )

2.1.7 Position ' 180° '

Figure 17 shows the voltage-energizing coils C and A (stator) and the permanent magnet realized with two pole pairs (rotor), as well as indicating the zero-crossing detection coil B. Figure 16 shows the active switches of the B6 bridge, and Figure 17 again the appropriate rotor position (180°):

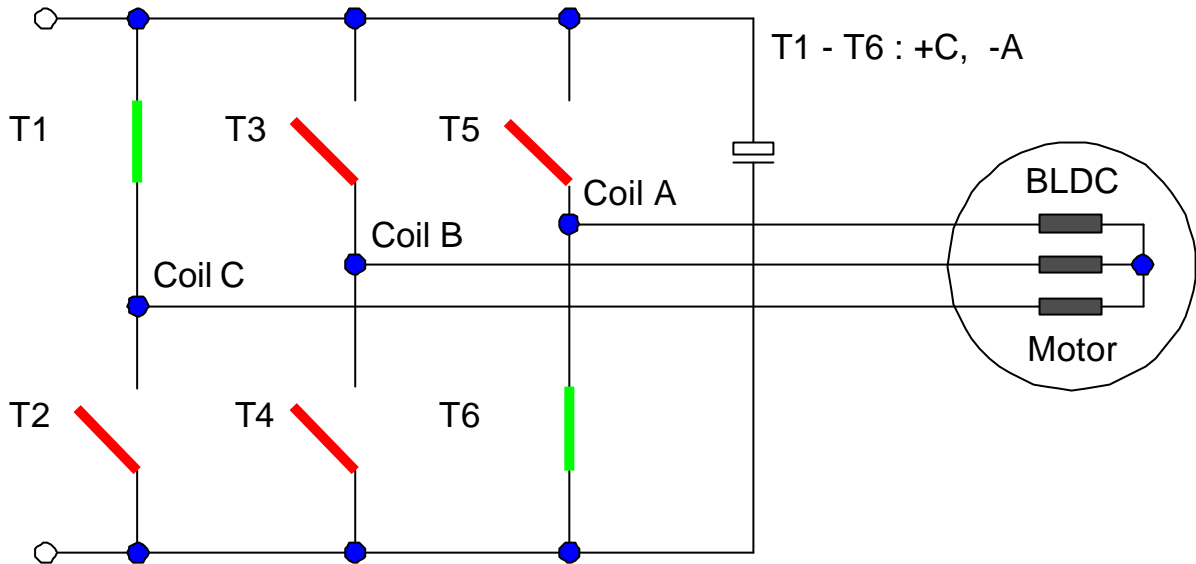

Figure 16: Appropriate switches T1, T6 of the B6 full-bridge ( coil C : pos., coil A : neg. )

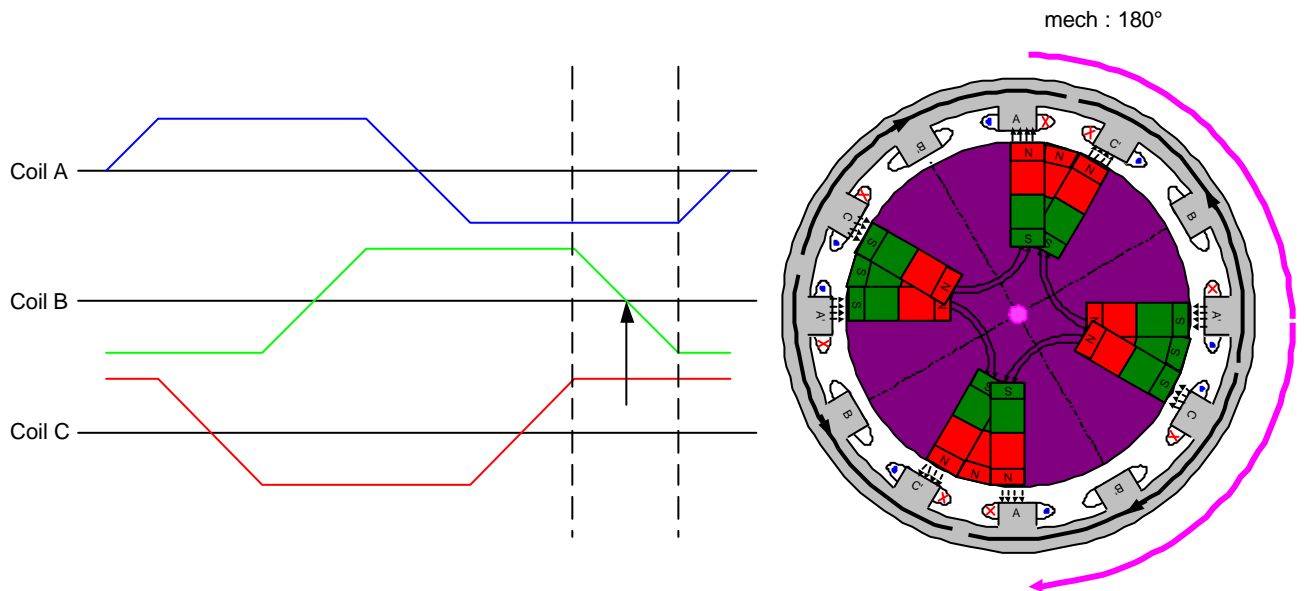

Figure 17: Energized coils A and C of a 2 pole-pair BLDC motor ( mechanical position : 180° )



## 2.2 Sensors

The BLDC motor is a synchronous motor and so the rotor position has to be known in order to generate the appropriate field.

### 2.2.1 Hall sensor output signal

Sensors are essential as a means of recognizing the positioning of a synchronous motor. The signals generated after appropriate signal conditioning are shown in Figure 18. Depending on the location of the Hall sensors and the number of pole pairs, different pictures emerge. In this case, a number of pole pairs are used and the three Hall sensors are located at a 120-degree distance.

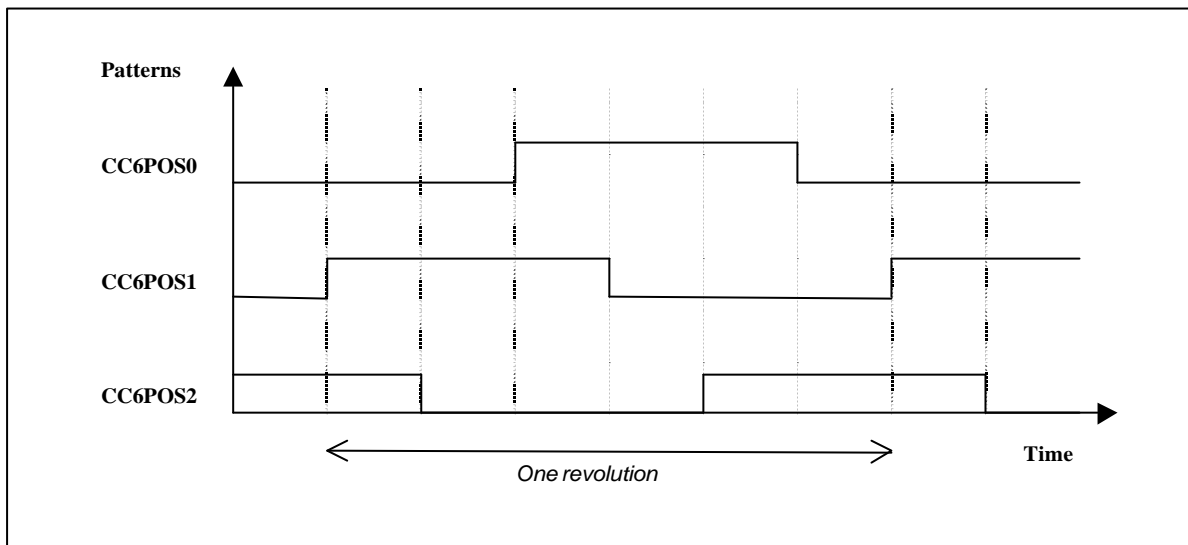

**Figure 18: Hall sensor signals**

Typically, the Hall signals are connected to the inputs of a microcontroller via a signal conditioning unit. For higher performance, the inputs of the microcontroller have to provide fast interrupt capability. To reduce system costs, the signal conditioning unit has to be moved either to the microcontroller or perhaps to driver IC.

Further reduction of CPU load is possible by using the CAPCOM6 unit of the C164CM. This supports the generation of the block commutation pattern without software support.

## 2.3 System description

### 2.3.1 Block diagram of block commutation using Hall sensors

Figure 19 shows a typical structure of a three-phase BLDC motor drive suitable for use in automotive applications, e.g. fan cooling or water pump. The C164CM microcontroller generates the rotation patterns for the stator field and can be used for speed or torque control. The TLE 6280 driver IC is used to provide the output signals for the 3-phase inverter and perform certain diagnostic functions such as short-circuit current protection, over-/undervoltage protection and overtemperature protection. OptiMOS devices arranged as three half-bridges switch the power to the corresponding phases of the BLDC motor.

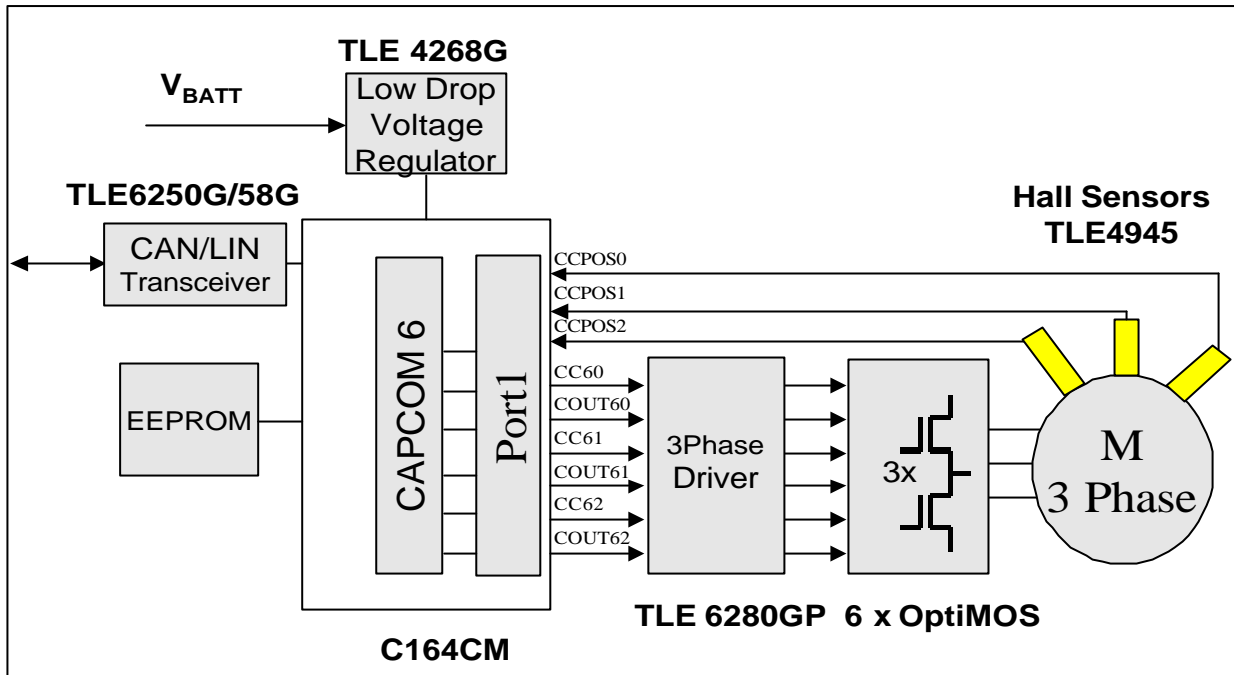

Figure 19: Block diagram of block commutation using Hall sensors

### 2.3.2 Block diagram of block commutation without sensors

Figure 20 shows a typical structure of a three-phase BLDC motor drive with B-EMF detection. It looks similar to the BLDC drive application with Hall sensors. The only difference is shown in the detection of the rotor position. The back-EMF voltage is recorded directly at each phase. A signal conditioning unit is required to trim the voltage (filtering, etc.). The zero cross voltage is detected for calculation of the next commutation pattern via the AD channels.

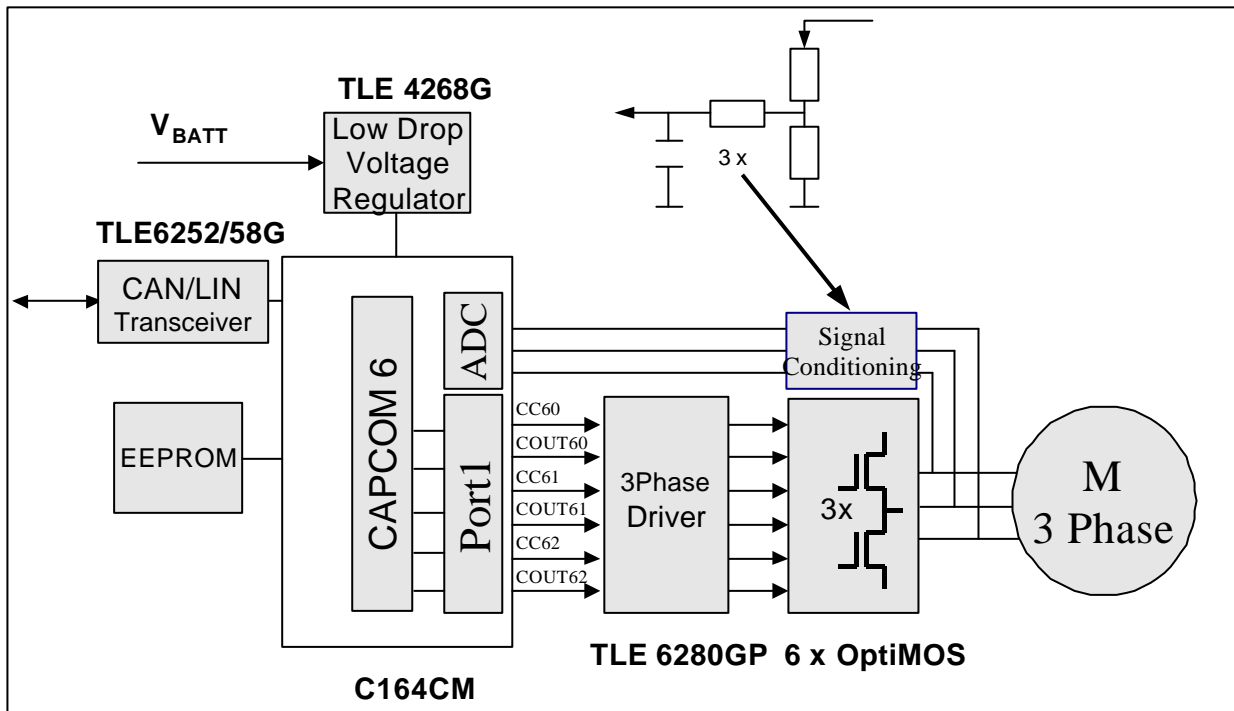
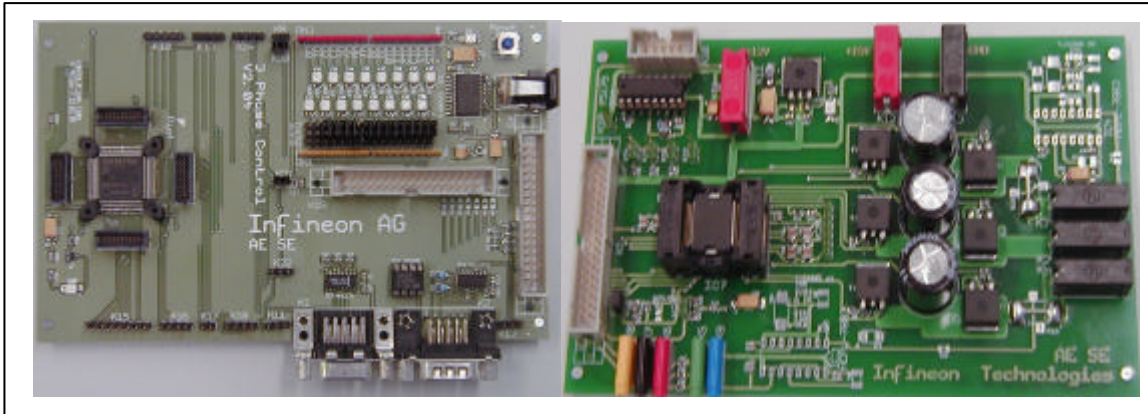

Figure 20: Block diagram of block commutation with B-EMF detection

Figure 21 shows a brushless DC motor evaluation kit. It is subdivided into a microcontroller board and a power board. In conjunction with an application node and a PC-driven interface, customers may start immediately with the evaluation of their own application.



**Figure 21: BLDC motor drive evaluation boards**

Infineon Technologies has all the semiconductors required for BLDC-driven applications. Figure 22 shows some of the devices needed for such applications.

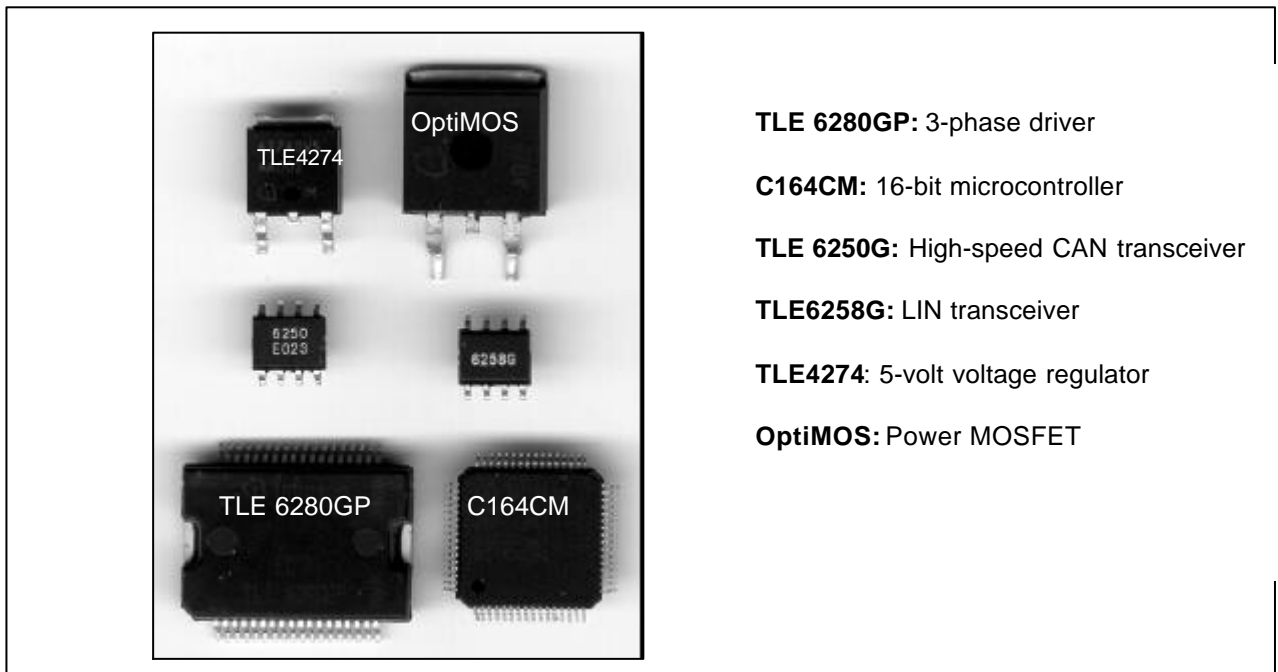

**Figure 22: Semiconductors for BLDC motor drive**

### 3 Block commutation mode with BACK-EMF detection

#### 3.1 General

As described in a previous section, the commutation of a brushless DC motor is performed electronically. The rectangular-shaped three-phase voltage system (see Figure 23) is used to generate a rotational field. Applied voltage with this easy-to-create shape helps ensure control and drive simplicity. The rotor position must be known at certain angles in order to align the applied voltage with the back-EMF, which is induced in the stator windings due to the movement of the permanent magnets on the rotor. Achieving alignment between the back-EMF and the commutation events is one of the main tasks. Under these conditions the motor behaves like a DC motor and runs at the best operating points. Simplicity of control and good performance makes this kind of motor a good choice in low-cost and high-efficiency applications.

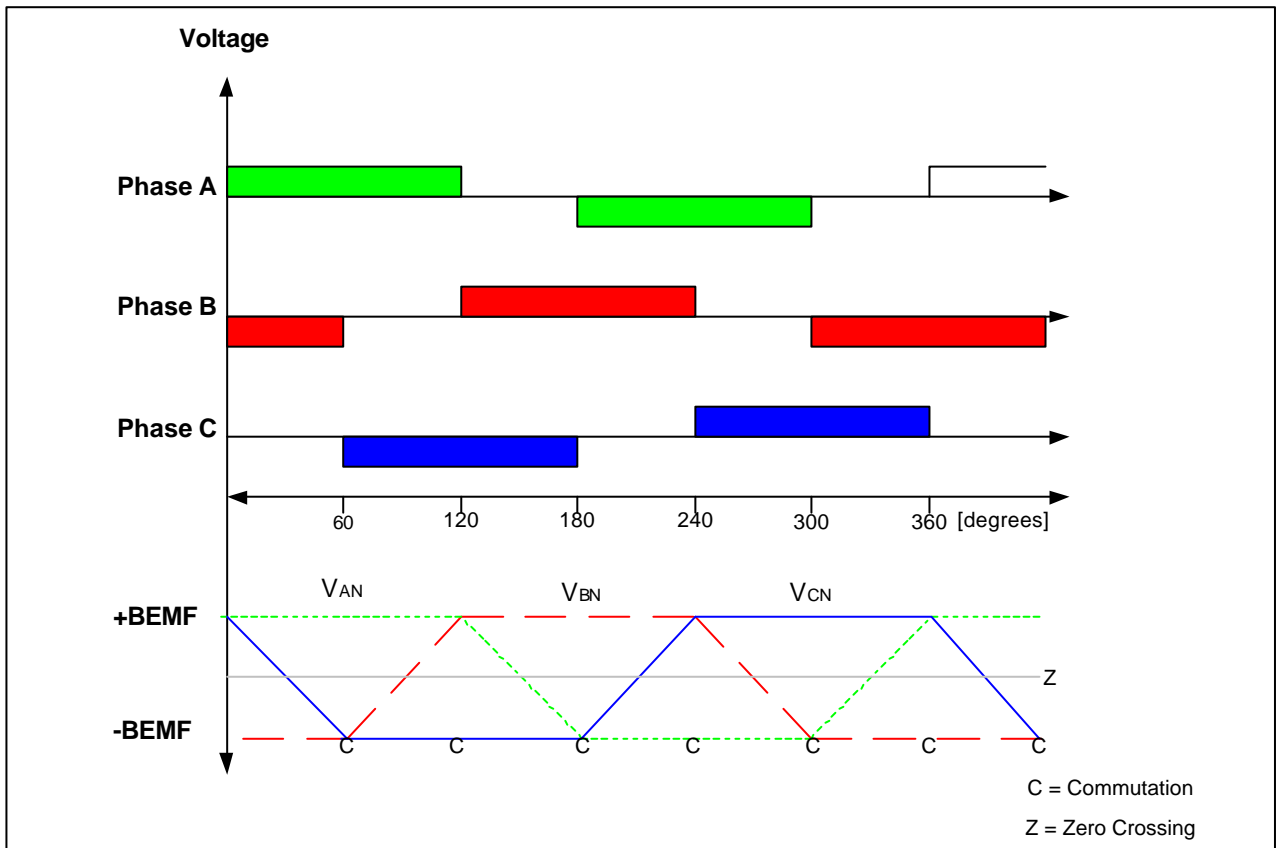
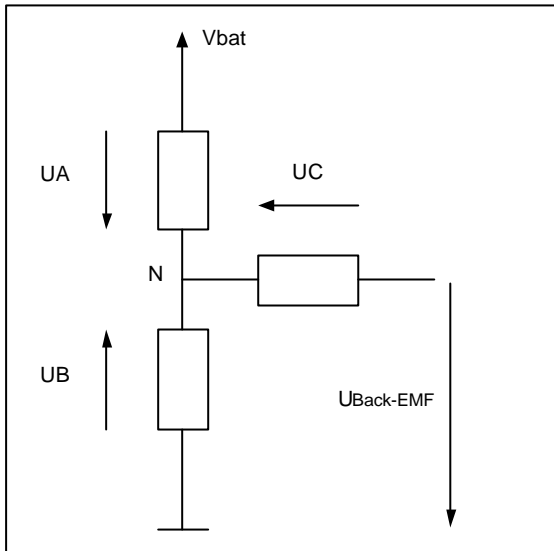

Figure 23: Simplified three-phase voltage system / back-EMF

##### 3.1.1 Back-EMF sensing

The back-EMF sensing technique is based on the fact that only two phases of a DC-brushless motor are connected at the same time, so the third phase can be used to sense the back-EMF voltage. Figure 24 uses a simple model to illustrate the situation when phases A and B are energized and phase C is used to measure the back-EMF.



**Figure 22: Simplified model of 3-phase BLDC (coils A and B are energized, coil C will be analyzed)**

Typically, methods to detect the zero crossing of the back-EMF often described in the literature utilize additional hardware such as OpAmps or other circuitry. Also, a speed-dependent phase delay time has been implemented to ensure proper commutation, and the external circuitry has been configured for a fixed motor speed. Overall, the costs for these additional components have a impact on total system costs.

To reduce system costs further, provide more flexibility and even chop one or both of the phases, another system approach might be considered. Each phase is connected via voltage divider circuitry and a low-pass filter to an AD channel of the C164CM. Each revolution of the rotor of a motor is divided into 6 commutation windows, each 60 degrees wide. For each window, an appropriate AD channel has been selected to detect the zero cross point in order to switch to the right commutation pattern after a dedicated phase delay time.

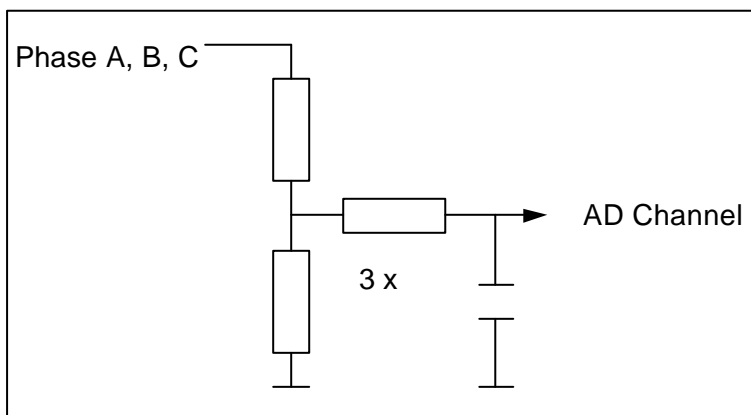

**Figure 25: Passive network for zero cross detection**

Basically, the external circuitry consists of a passive network such as that shown in Figure 25. The network includes a voltage divider circuit and a low-pass filter with a cut-off frequency of 1 kHz. One network is required for each phase.

Because the back-EMF voltage is a function of the rotor speed, an AD converter with a higher resolution, at least 10-bit, is required.

Figure 26 shows the phase voltage (Channels 1 to 3) of a 3-phase BLDC motor at the inputs of the AD channels. The rotation speed of the motor is around 1000 rpm. Channel 4 represents the required CPU load.

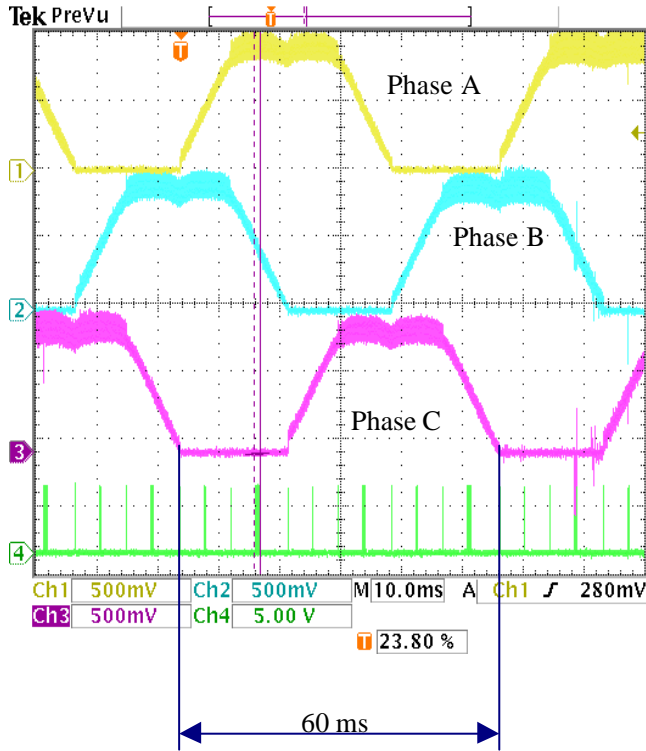
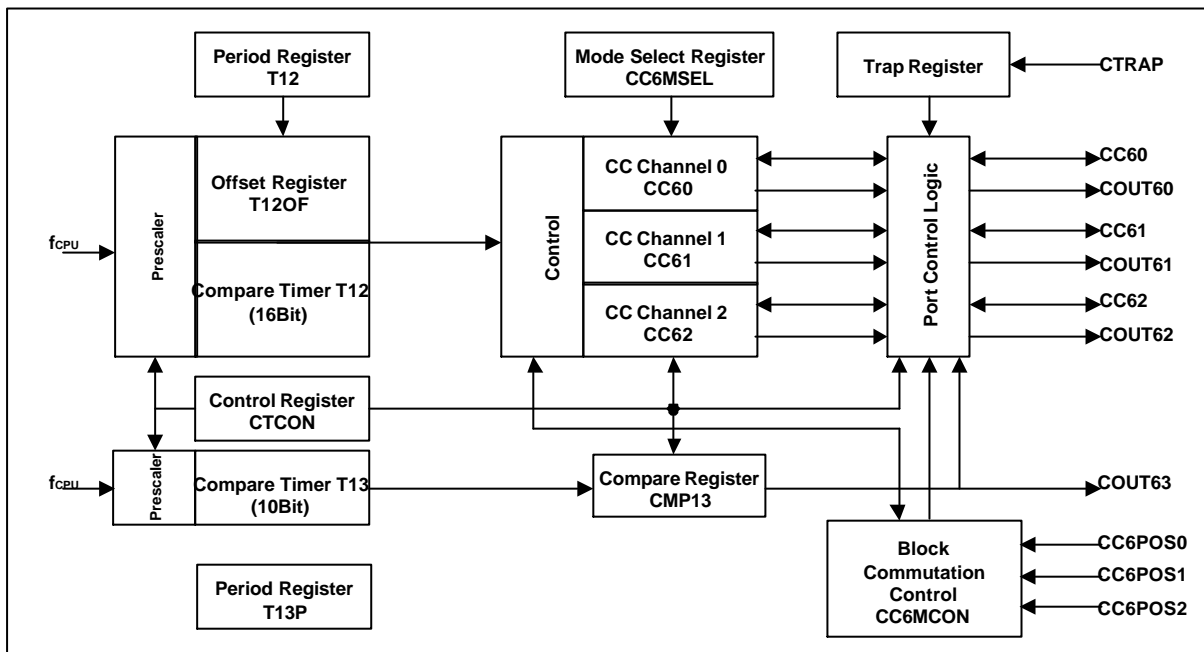

Figure 26: Back-EMF voltage after low-pass filter

## 3.2 Required peripherals

### 3.2.1 CAPCOM6

The CAPCOM6 unit of the C164CM has been designed for applications with a requirement for digital signal generation and event capturing (e.g. pulse width modulation, pulse width measurement). It supports generation and control of timing sequences on up to three 16-bit capture / compare channels plus one additional 10-bit compare timer. This peripheral fulfills all requirements for controlling 3-phase or multiphase motor drives.



**Figure 27: Block diagram of CAPCOM6 unit**

In the compare mode used for driving BLDC motors, the CAPCOM6 provides two output signals per 16-bit channel, which may have inverted polarity pulse transitions. Timer T12 can be used to control the commutation speed. Timer 13 can be used to modulate the capture/compare outputs to influence the speed/torque of the motor. For active freewheeling, a dead time generation is mandatory. It can be realized with offset register T12OF. For more detailed information about the CAPCOM6 unit please refer to the C164 manual or to application note 1673 (technical details on CAPCOM6 unit).

### 3.2.2 ADC

The Analog Digital Converter of the C164CM has been designed to measure up to eight analog sources with 10-bit resolution. It consists of a sample and hold circuit. A multiplexer allows up to eight analog input channels to be selected. To fulfill the different requirements of embedded applications, the peripheral supports several conversion modes, such as fixed channel conversion, autoscan conversions or channel injection modes. The minimum conversion time is dependent on the CPU frequency and can be programmed. The minimum conversion time is 9.7  $\mu\text{s}$  (fcpu @ 20 MHz). For more detailed information please refer to the datasheet or the user manual.

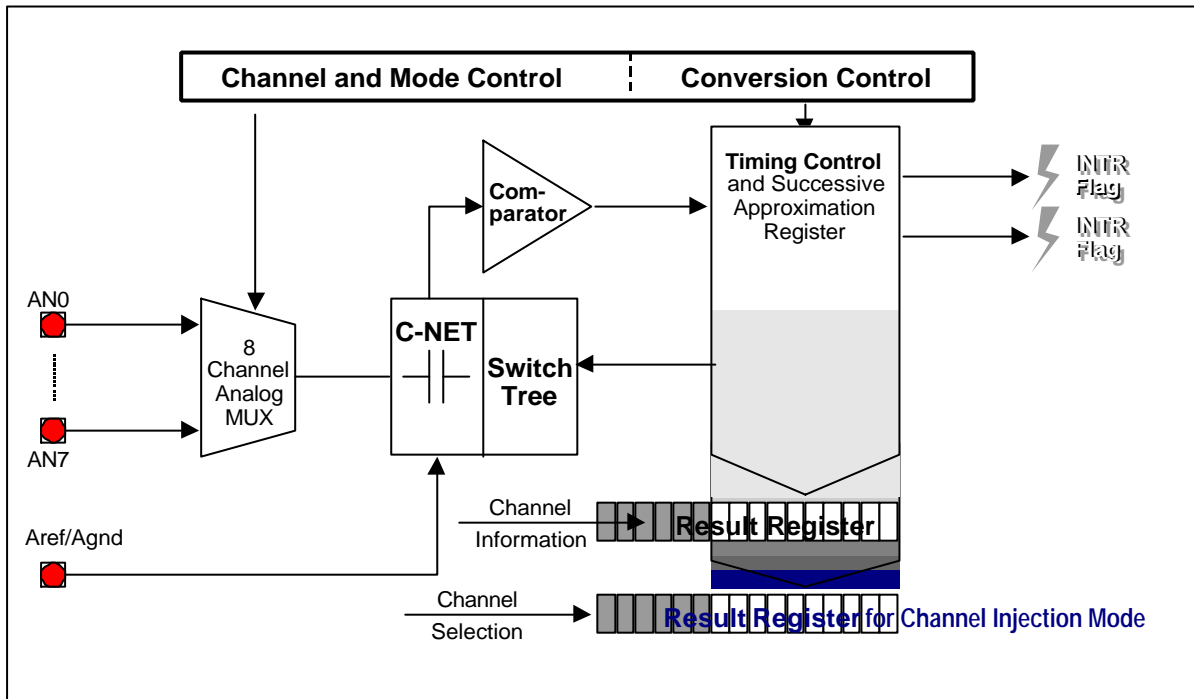

Figure 28: Block diagram of ADC unit



## 4 Implementation

### 4.1 Functional description

#### 4.1.1 General description

The application is divided into several subfunctions. First, all relevant peripherals are configured. Next, the rampup phase is started to accelerate the motor. During this phase, the commutation speed and the phase voltage are increased continuously until the back-EMF voltage is interpretable. Now, the back-EMF detection and an optional PI controller for speed or torque control may be activated.

Figure 29 provides an overview of the event-driven flow process.

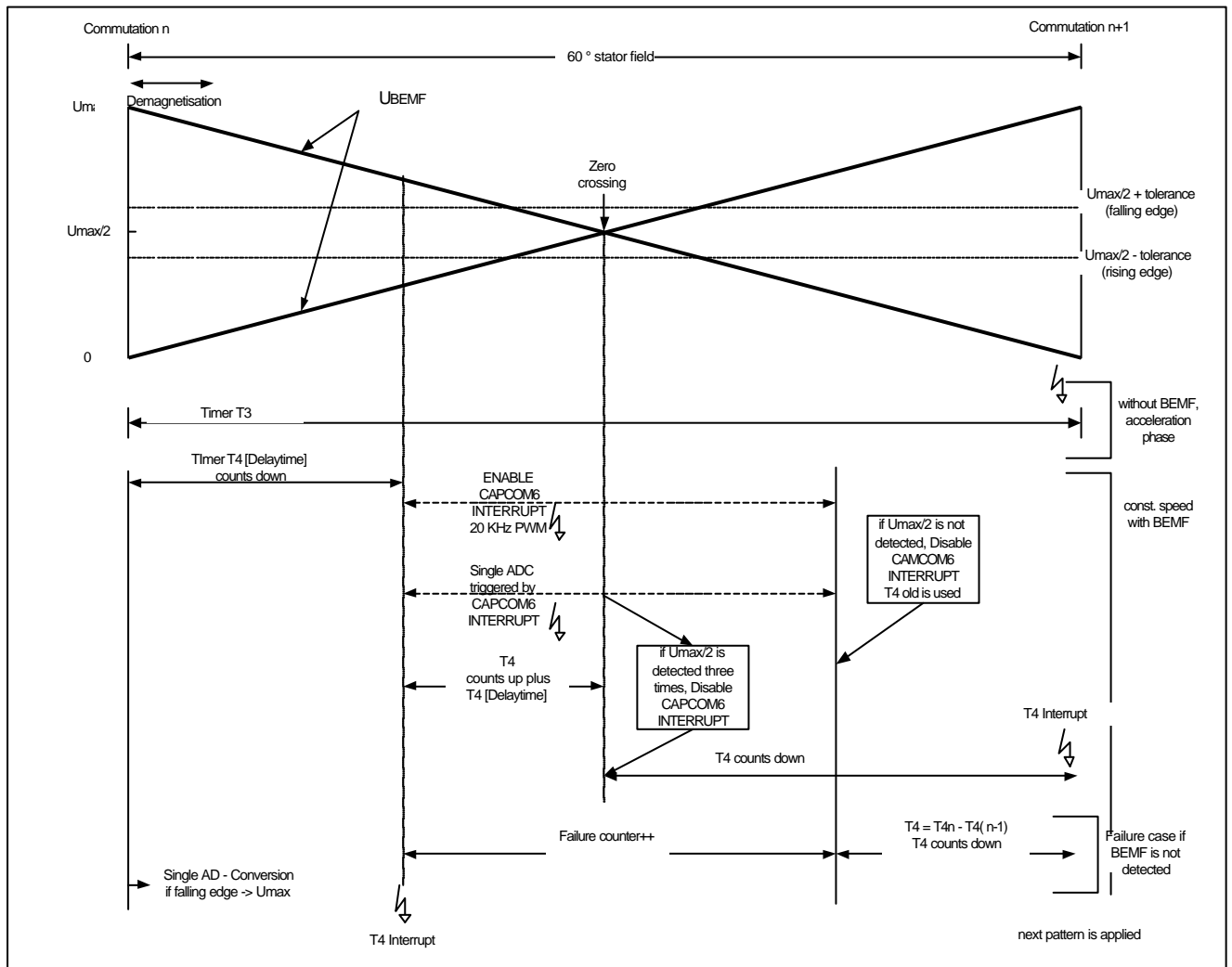

Figure 29: Event flow process

#### 4.1.2 Management of commutation, demagnetization and zero cross detection

The sensorless control process of the BLDC motor is based on the following events:

Commutation event (CAPCOM6 unit)

End of demagnetization (Timer T4)

Zero cross detection (ADC)

Each 60-degree window is initiated with a new commutation pattern. Timer T4 is utilized to generate a delay time between the start of the demagnetization impact and the point in time where the zero cross event gets closer. This value of timer T4 is strongly dependent on the motor type and the required motor speed. The timer T4 interrupt enables the CAPCOM6 interrupt. The CAPCOM6 interrupt forces an AD conversion of the appropriate phase voltage every 50  $\mu$ s (20 kHz PWM). If the converted voltage value is very close to the requested value three times, then a zero cross detection is recognized. In the interim, timer T4 is used to monitor the elapsed time. Depending on motor type and speed, the requested time is now calculated for the next commutation pattern. It is possible that the zero cross event is not recognized due to external noise. In this case a failure counter is incremented and switches off the AD sampling of the phase voltage. The requested time for the next commutation pattern is calculated based on previous values. All tasks are interrupt-driven and consume little microcontroller-related time.

## 4.2 Implementation of the software

The software is divided into several routines.

Initialization (ports, CAPCOM6, GPT1 (timer T3/T4))

State machine (6 commutation states)

PI controller for closed loop (optional)

Interrupt routines:

CAPCOM 6

Timer T4

Timer T3 (only used for the motor rampup time)

ADC

#### 4.2.1 Initialization

A number of small routines perform all the necessary initializations before the motor is started:

Port initialization: P1L.0 – P1L5 (CCx, COUx) output

Interrupt initialization: CAPCOM6 emergency (CC6EIC), CAPCOM6 (CC6CIC), ADC interrupt (ADCIC), timer T3 (T3IC), timer T4 (T4IC).

CAPCOM6 initialization: Disable multichannel mode, passive output level is low, set timer T12 (PWM 20 kHz), set compare register CCx to start value, center

aligned mode, active dead time generation, enable ext. trap function for emergency cases

ADC initialization: Select P5.3-P5.5 as AD channels, fixed-channel single conversion, sample time 1.6  $\mu$ s, conversion time 9.7  $\mu$ s

Timer initialization: Timer T3/T4 in timer mode, prescaler 16, external up/down control disabled

#### 4.2.2 State machine

The state machine is required to generate the block commutation pattern for both directions. The appropriate outputs and AD channels are also selected.

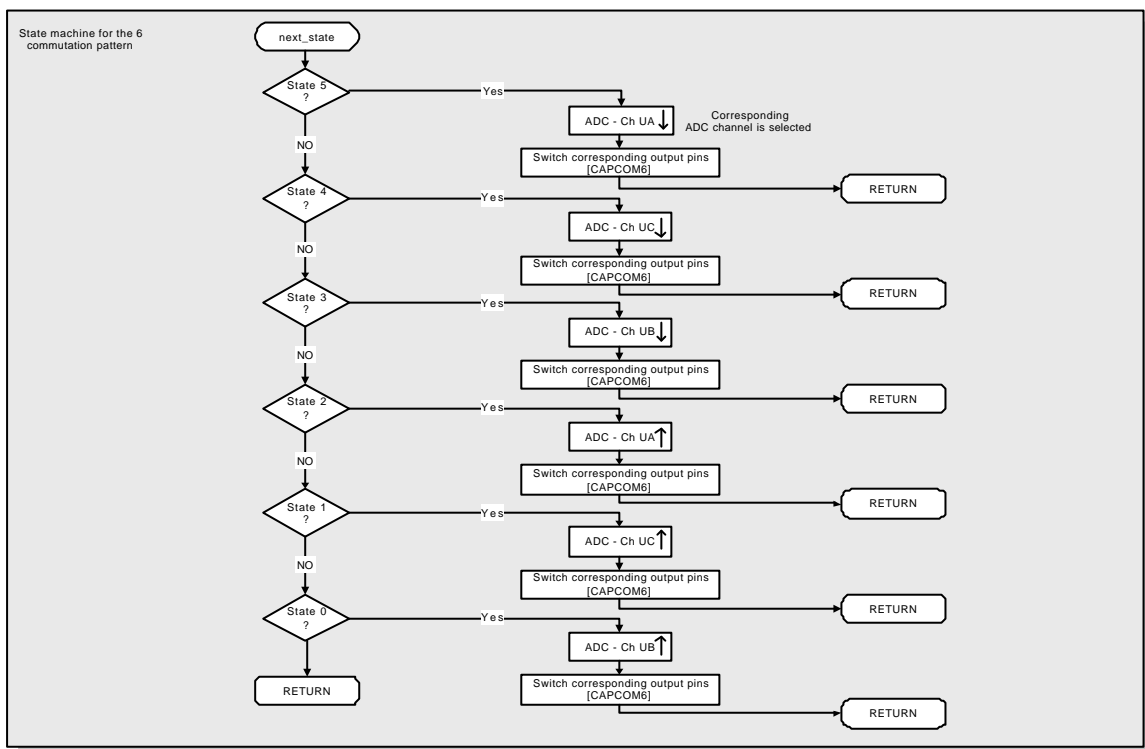

Figure 30: State machine flowchart

**Note:** The CAPCOM6 unit of the C164CM overcomes the limitation for block commutation mode! Pattern generation for both directions operates properly.

#### 4.2.3 Interrupt routines

The timer T3 interrupt function is applied only for the rampup phase of the motor. It generates and changes the commutation period and the voltage level for the three phases. Upon reaching the minimum rotation speed of the motor, the timer T3 interrupt routine is disabled.

The rampup behavior of the motor is shown in Figure 31. The rampup process is divided into three steps. In the first step, the motor is accelerated from 0 rpm up to the minimum rotation speed in order to analyze the BEMF detection voltage. Depending on the static torque of the motor, the dV/dT ratio of the acceleration graph has to be configured. The second step handles the BEMF detection and the

synchronization to the appropriate commutation pattern. If the BEMF detection has been successful, then the motor speed can be accelerated up to the required value.

The timer T4 interrupt routine is enabled after back-EMF detection becomes active. It handles the whole process of each 60-degree window (demagnetization, monitoring of the window length, point in time for commutation, etc.). ADC interrupt routines validate the current voltage level and take the decision for zero cross detection. The CAPCOM6 interrupt routine forces an AD conversion every 50  $\mu$ s. It can be enabled by the timer T3 interrupt routine.

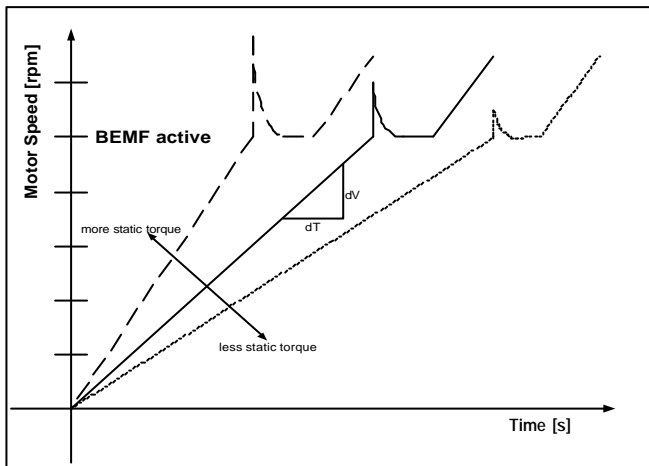

Figure 31: Ramp behavior

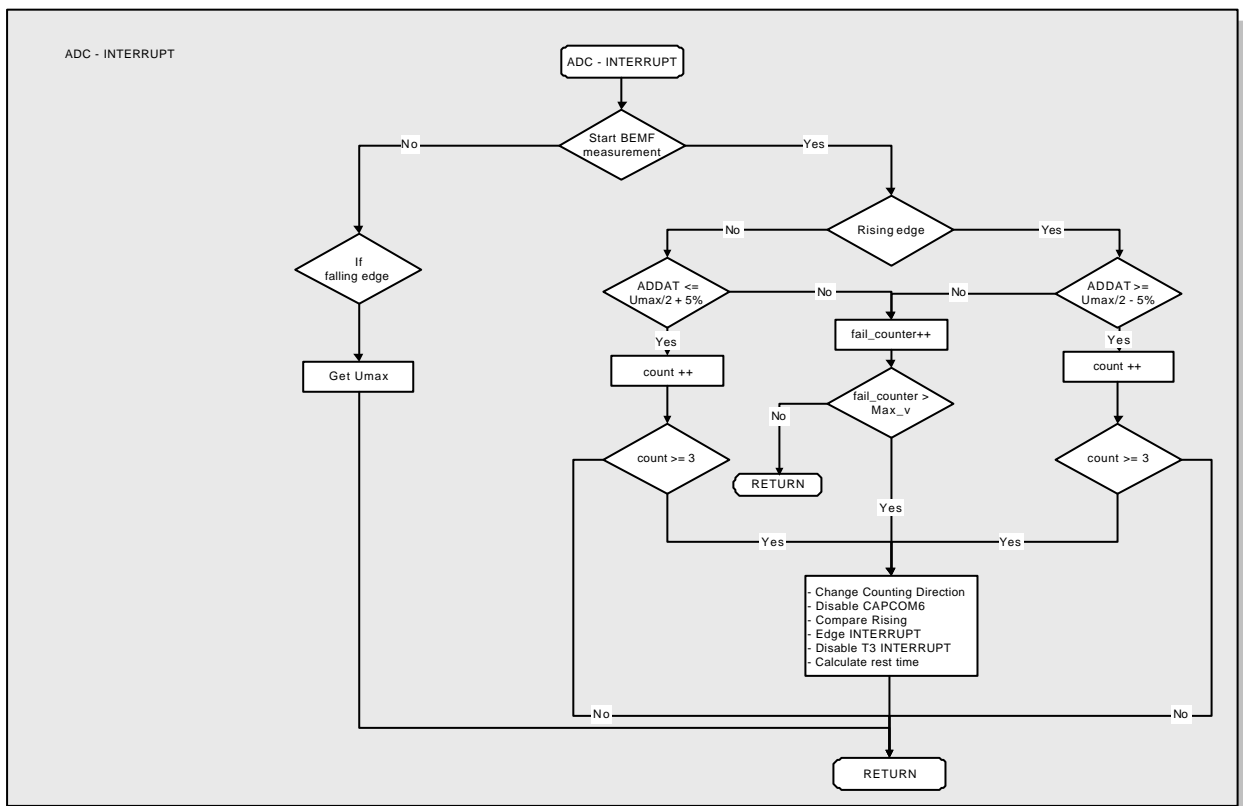

Figure 32: Zero cross detection flowchart

### 4.3 Performance analysis

#### 4.3.1 Hardware requirements

CPU: 16xCPU (16-bit, 20 MHz)

ROM: 1KB – 2 KB depending on error detection requirements

RAM: 200 bytes plus system stack

Peripherals: CAPCOM6 unit: 16-bit timer, 50 ns resolution, three 16-bit capture/compare channels

ADC: 3-channel, 10-bit resolution, 9.7µs conversion time

Timer: 16 timer, 400ns resolution

#### 4.3.2 CPU load

The CPU load was measured in a simple way. A flag of a dedicated port pin is set each time an interrupt routine is entered. The flag is reset after the interrupt routine is exited.

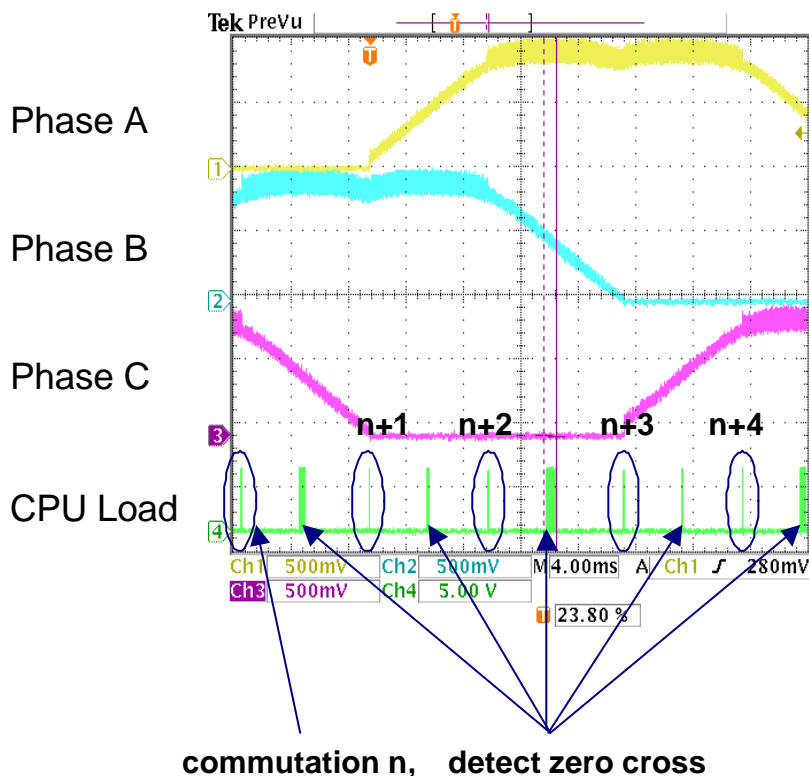

Figure 33: CPU load

The CPU load depends greatly on how close to the zero cross point the AD conversions starts. It is therefore mandatory to optimize the application for the motor used. Here is a rough overall estimation of the CPU load without optimization:



## Sensorless Regulation of a Brushless DC Motor with a C164CM

**CPU frequency: 20 MHz**

**Motor speed 1000 rpm, one pole pair**

**CPU load typically: 3 %**

The CPU load depends greatly on how close to the zero cross point the AD conversion starts. The CPU load may be decreased by using the DMA feature (PEC transfer) instead of continuous verification of the phase voltage.

## 5 Conclusion

There is an increasing demand in the automotive industry for applications using BLDC motors. In the past, many applications were addressed with DC motors. Automotive suppliers would like to use BLDC motors in order to achieve greater robustness and efficiency. Currently, the only limitation is the price gap between BLDC motors and DC motors. On the other hand, automotive suppliers are intensely price-driven and need smart solutions to meet the requirements of the market.

This application note aims to provide an understanding of the functionality of a BLDC motor, explains how such a motor is driven, describes all the necessary components and the necessity of knowing the positioning of a synchronous motor. Furthermore, the back-EMF technique is discussed and a method to implement the back-EMF algorithm in the C164CM is presented. To achieve a good price/performance ratio, all the components used for back-EMF detection have been replaced by software. Thanks to the high performance of the microcontroller and its powerful peripherals, this software solution consumes only limited CPU resources.

The system approach discussed might be considered as a starting point for designing a complete system-specific closed-loop BLDC application

## 6 Abbreviations

ADC:	Analog Digital Converter
BACK-EMF :	Back electromagnetic force
B6 :	Bridge with 6 switches (e.g. MOSFET) for 3 phases
BLDC:	Brushless DC
CAN:	Controller Area Network
CAPCOM:	Capture Compare Unit, peripheral that measure events or provide PWM signal
CPU:	Central Processor Unit
EHPS:	Electro Hydraulic Power Steering
LIN:	Local Interconnect Network
PI:	Proportional Integral
PWM:	Pulse width modulation
ROM:	Read only memory
RAM:	Read Access Memory