

BGA925L6

Optimizing Rejection of LTE Band-13 (777-787 MHz) Jammers Using 0201 Components

Application Note AN266

Revision: Rev. 1.1
2012-03-21

Edition 2012-04-24

**Published by
Infineon Technologies AG
81726 Munich, Germany**

**© 2012 Infineon Technologies AG
All Rights Reserved.**

LEGAL DISCLAIMER

THE INFORMATION GIVEN IN THIS APPLICATION NOTE IS GIVEN AS A HINT FOR THE IMPLEMENTATION OF THE INFINEON TECHNOLOGIES COMPONENT ONLY AND SHALL NOT BE REGARDED AS ANY DESCRIPTION OR WARRANTY OF A CERTAIN FUNCTIONALITY, CONDITION OR QUALITY OF THE INFINEON TECHNOLOGIES COMPONENT. THE RECIPIENT OF THIS APPLICATION NOTE MUST VERIFY ANY FUNCTION DESCRIBED HEREIN IN THE REAL APPLICATION. INFINEON TECHNOLOGIES HEREBY DISCLAIMS ANY AND ALL WARRANTIES AND LIABILITIES OF ANY KIND (INCLUDING WITHOUT LIMITATION WARRANTIES OF NON-INFRINGEMENT OF INTELLECTUAL PROPERTY RIGHTS OF ANY THIRD PARTY) WITH RESPECT TO ANY AND ALL INFORMATION GIVEN IN THIS APPLICATION NOTE.

Information

For further information on technology, delivery terms and conditions and prices, please contact the nearest Infineon Technologies Office (www.infineon.com).

Warnings

Due to technical requirements, components may contain dangerous substances. For information on the types in question, please contact the nearest Infineon Technologies Office.

Infineon Technologies components may be used in life-support devices or systems only with the express written approval of Infineon Technologies, if a failure of such components can reasonably be expected to cause the failure of that life-support device or system or to affect the safety or effectiveness of that device or system. Life support devices or systems are intended to be implanted in the human body or to support and/or maintain and sustain and/or protect human life. If they fail, it is reasonable to assume that the health of the user or other persons may be endangered.

Application Note AN266
Revision History: 2012-03-21
Previous Revision: Rev. 1.0, 2011-07-25

Page	Subjects (major changes since last revision)
8	Values in Table-2 updated
11	Value of L3 changed from 6.2 nH to 5.6 nH
12-21	Marker position changed and corresponding values updated, S-parameter graphs updated

Trademarks of Infineon Technologies AG

AURIX™, C166™, CanPAK™, CIPOS™, CIPURSE™, EconoPACK™, CoolMOS™, CoolSET™, CORECONTROL™, CROSSAVE™, DAVE™, DI-POL™, EasyPIM™, EconoBRIDGE™, EconoDUAL™, EconoPIM™, EconoPACK™, EiceDRIVER™, eupec™, FCOS™, HITFET™, HybridPACK™, I²RF™, ISOFACE™, IsoPACK™, MIPAQ™, ModSTACK™, my-d™, NovalithIC™, OptiMOS™, ORIGA™, POWERCODE™, PRIMARION™, PrimePACK™, PrimeSTACK™, PRO-SIL™, PROFET™, RASIC™, ReverSave™, SatRIC™, SIEGET™, SINDRION™, SIPMOS™, SmartLEWIS™, SOLID FLASH™, TEMPFET™, thinQ!™, TRENCHSTOP™, TriCore™.

Other Trademarks

Advance Design System™ (ADS) of Agilent Technologies, AMBA™, ARM™, MULTI-ICE™, KEIL™, PRIMECELL™, REALVIEW™, THUMB™, μVision™ of ARM Limited, UK. AUTOSAR™ is licensed by AUTOSAR development partnership. Bluetooth™ of Bluetooth SIG Inc. CAT-iq™ of DECT Forum. COLOSSUS™, FirstGPS™ of Trimble Navigation Ltd. EMV™ of EMVCo, LLC (Visa Holdings Inc.). EPCOS™ of Epcos AG. FLEXGO™ of Microsoft Corporation. FlexRay™ is licensed by FlexRay Consortium. HYPERTERMINAL™ of Hilgraeve Incorporated. IEC™ of Commission Electrotechnique Internationale. IrDA™ of Infrared Data Association Corporation. ISO™ of INTERNATIONAL ORGANIZATION FOR STANDARDIZATION. MATLAB™ of MathWorks, Inc. MAXIM™ of Maxim Integrated Products, Inc. MICROTEC™, NUCLEUS™ of Mentor Graphics Corporation. MIPI™ of MIPI Alliance, Inc. MIPS™ of MIPS Technologies, Inc., USA. muRata™ of MURATA MANUFACTURING CO., MICROWAVE OFFICE™ (MWO) of Applied Wave Research Inc., OmniVision™ of OmniVision Technologies, Inc. Openwave™ Openwave Systems Inc. RED HAT™ Red Hat, Inc. RFMD™ RF Micro Devices, Inc. SIRIUS™ of Sirius Satellite Radio Inc. SOLARIS™ of Sun Microsystems, Inc. SPANSION™ of Spansion LLC Ltd. Symbian™ of Symbian Software Limited. TAIYO YUDEN™ of Taiyo Yuden Co. TEAKLITE™ of CEVA, Inc. TEKTRONIX™ of Tektronix Inc. TOKO™ of TOKO KABUSHIKI KAISHA TA. UNIX™ of X/Open Company Limited. VERILOG™, PALLADIUM™ of Cadence Design Systems, Inc. VLYNQ™ of Texas Instruments Incorporated. VXWORKS™, WIND RIVER™ of WIND RIVER SYSTEMS, INC. ZETEX™ of Diodes Zetex Limited.

Last Trademarks Update 2011-11-11



Table of Content

1	BGA925L6 GPS Front-End LNA for High Performance Integrated Solution.....	6
2	Introduction	7
3	Application Circuit	11
4	Typical Measurement Results.....	12
5	Measured Graphs for COMPASS, Galileo, GPS and GLONASS bands	14
6	Miscellaneous Measured Graphs	19
7	Evaluation Board.....	22
8	Authors.....	23

List of Figures

Figure 1	BGA925L6 in TSLP-6-2 Package (0.70mm x 1.1mm x 0.40mm)	6
Figure 2	BGA925L6 package size in comparison with 0402 and 0201 components	9
Figure 3	Block diagram of the BGA925L6 for GNSS band 1559-1615MHz applications	10
Figure 4	BGA925L6 application circuit	11
Figure 5	Power gain of BGA925L6 for COMPASS, Galileo, GPS and GLONASS bands	14
Figure 6	Narrowband power gain of BGA925L6 for COMPASS, Galileo, GPS and GLONASS bands.....	14
Figure 7	Input matching of BGA925L6 for COMPASS, Galileo, GPS and GLONASS bands	15
Figure 8	Output matching of BGA925L6 for COMPASS, Galileo, GPS and GLONASS bands	15
Figure 9	Reverse isolation of BGA925L6 for COMPASS, Galileo, GPS and GLONASS bands	16
Figure 10	Noise figure of BGA925L6 for COMPASS, Galileo, GPS and GLONASS bands.....	16
Figure 11	Input 1 dB compression point of BGA925L6 at supply voltage of 1.8V for COMPASS, Galileo, GPS and GLONASS bands	17
Figure 12	Input 1 dB compression point of BGA925L6 at supply voltage of 2.8V for COMPASS, Galileo, GPS and GLONASS bands	17
Figure 13	Carrier and intermodulation products of BGA925L6 for GPS band at Vcc=1.8V	18
Figure 14	Carrier and intermodulation products of BGA925L6 for GPS band at Vcc=2.8V	18
Figure 15	Stability factor k of BGA925L6 upto 10GHz.....	19
Figure 16	Stability factor μ_1 of BGA925L6 upto 10GHz.....	19
Figure 17	Stability factor μ_2 of BGA925L6 upto 10GHz.....	20
Figure 18	Input and output matching for COMPASS, Galileo, GPS and GLONASS bands with Vcc=1.8V	20
Figure 19	Input and output matching for COMPASS, Galileo, GPS and GLONASS bands with Vcc=2.8V	21
Figure 20	Populated PCB picture of BGA925L6	22
Figure 21	PCB layer stack.....	22

List of Tables

Table 1	BGA925L6 with different circuit topologies	8
Table 2	Comparison of different application circuits at supply voltage of 2.8V	8
Table 3	Pin Definition	10
Table 4	Switching Mode	10
Table 5	Bill-of-Materials.....	11
Table 6	Electrical Characteristics (at room temperature), Vcc = Vpon = 1.8 V	12
Table 7	Electrical Characteristics (at room temperature), Vcc = Vpon = 2.8 V	13

1 BGA925L6 GPS Front-End LNA for High Performance Integrated Solution

1.1 Features

- High gain: 15.8 dB
- High out-of-band input 3rd-order intercept point: +7 dBm
- High input 1dB compression point: -5 dBm
- Low noise figure: 0.65 dB
- Low current consumption: 4.8 mA
- Operating frequency: 1550-1615 MHz
- Supply voltage: 1.5 V to 3.6 V
- Digital on/off switch (1V logic high level)
- Ultra small TSLP-6-2 leadless package
- Package dimensions: 0.70mm x 1.1mm x 0.40mm
- B7HF Silicon Germanium technology
- RF output internally matched to 50 Ω
- Only two external SMD components necessary
- 2 kV HBM ESD protection (including AI-pin)
- Pb-free (RoHS compliant) package



Figure 1 BGA925L6 in TSLP-6-2 Package (0.70mm x 1.1mm x 0.40mm)

1.2 Applications

- GPS (Global Positioning System) working in the L1 band at 1575.42 MHz
- GLONASS (Russian GNSS) working in the L1 band from 1598.06 MHz to 1605.38 MHz
- Galileo (European GNSS) working in the E2-L1-E1 band from 1559 MHz to 1592 MHz
- COMPASS (Chinese Beidou Navigation System) working in E2 band at 1561.10 MHz and E1 band at 1589.74 MHz

2 Introduction

The BGA925L6 is a front-end Low Noise Amplifier (LNA) for Global Navigation Satellite Systems (GNSS) application. It is based on Infineon Technologies' B7HF Silicon-Germanium (SiGe:C) technology, enabling a cost-effective solution in a ultra small TSLP-6-2 package with ultra low noise figure, high gain, high linearity and low current consumption over a wide range of supply voltages from 3.6 V down to 1.5 V. All these features make BGA925L6 an excellent choice for GNSS LNA as it improves sensitivity, provide greater immunity against out-of-band jammer signals, reduces filtering requirement and hence the overall cost of the GNSS receiver.

The GNSS satellites are at an orbit altitude of more than 20,000 km away from earth's surface and transmit power in the range of +47 dBm. After taking losses (atmospheric, antenna etc.) into account, the received signal strength at the GNSS device input is very low in the range of -130 dBm. The ability of the GNSS device to receive such a low signal strength and provide meaningful information to the end-user depends strongly on the noise figure of the GNSS receive chain. This ability which is called receiver sensitivity can be improved by using a low-noise amplifier with low noise figure and high gain at the input of the receiver chain. The improved sensitivity results in a shorter Time-To-First-Fix (TTFF), which is the time required for a GNSS receiver to acquire satellite signals and navigation data, and calculate a position. Noise figure of the LNA defines the overall noise figure of the GNSS receiver system. This is where BGA925L6 excels by providing noise figure as low as 0.65 dB and high gain of 15.8 dB, thereby improving the receiver sensitivity significantly.

The ever growing demand to integrate more and more functionality into one device leads to many challenges when transmitter/receiver has to work simultaneously without degrading the performance of each other. In today's smart-phones a GNSS receiver simultaneously co-exists with transceivers in the GSM/EDGE/UMTS/LTE bands. These 3G/4G transceivers transmit high power in the range of +24 dBm which due to insufficient isolation couple to the GNSS receiver. The cellular signals can mix to produce Intermodulation products exactly in the GNSS receiver frequency band. For example, GSM 1712.7 MHz mixes with UMTS 1850 MHz to produce third-order-product exactly at GPS. To quantify the effect, BGA925L6 shows

out-of-band input IP3 at GPS of +8.1 dBm as a result of frequency mixing between GSM 1712.7 MHz and UMTS 1850 MHz with power levels of -20 dBm and -65 dBm. BGA925L6 has a high out-of-band input 3rd order intercept point (IIP3) of +8.1 dBm, so that it is especially suitable for the GPS function in mobile phones.

Another issue which is frequently encountered in Smartphones nowadays, is the 2nd harmonic of LTE Band-13 operating at 787.76 MHz. The 2nd harmonic of LTE Band-13 falls exactly into the GPS band. **In this application note BGA925L6 has been optimized to keep noise figure below 1.0 dB and also input referred band-13 2nd harmonic level of below -120 dBm.**

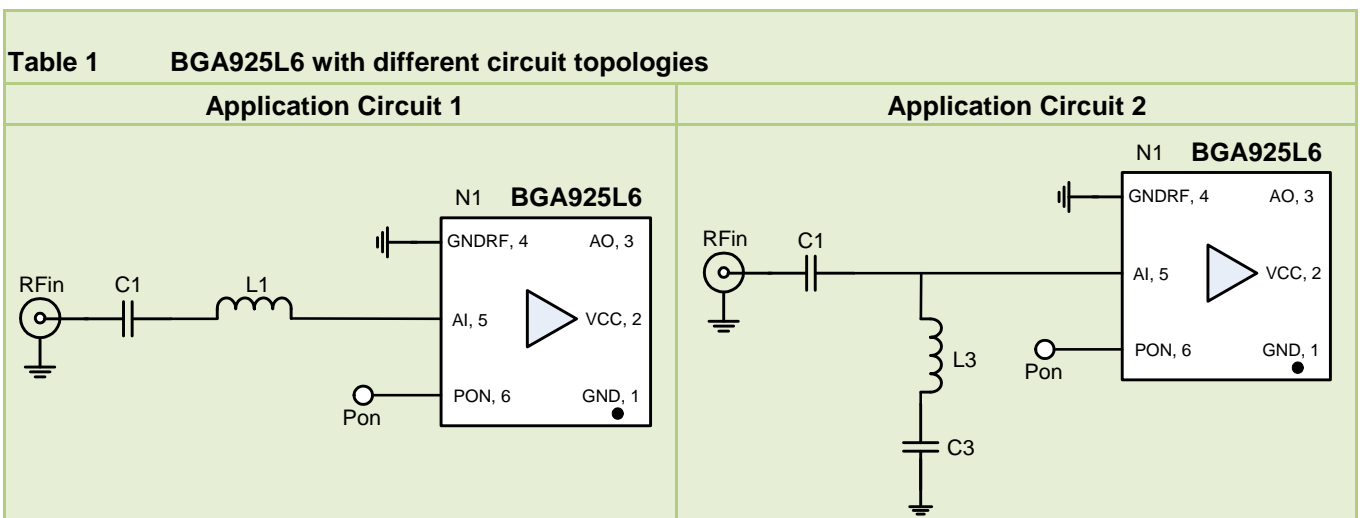

Table 2 Comparison of different application circuits at supply voltage of 2.8V

Application circuit	Component values	Noise Figure [dB]	Band-13 2 nd harmonic* [dBm]	Out-of-band Input IP3** [dBm]	S21 @ 1575.42 MHz [dB]	S21 @ 787.76 MHz [dB]
Circuit 1	C1=2pF, L1=10nH	1.0	-56.1	6.7	15.80	2.53
Circuit 2	C1=2pF, L3=5.6nH, C3=6.8pF	0.96	-124.3	8.1	15.50	-32.4
AN265	C1=1nF, L1=6.2nH	0.74	-47.5	9.5	15.76	6.87
AN267	C1=2.7pF, L3***=6.2nH, C3=6.8pF	0.83	-119.7	7.5	15.60	-30.8

*This level is input-referred.
 **Test conditions: $f_{1IN} = 1712.7 \text{ MHz}$, $P_{1IN} = -20 \text{ dBm}$, $f_{2IN} = 1850 \text{ MHz}$, $P_{2IN} = -65 \text{ dBm}$
 ***Only this inductor in above application circuits is 0402 size and rest are of 0201 size.

Depending upon requirement, BGA925L6 performance can be optimized using various component values or circuit topologies. As can be seen from Table 2, different application circuits are designed to optimize noise figure and band-13 2nd harmonic. This is achieved by using three 0201 size external SMDs; two capacitors and one inductor¹. The L3-C3 series combination is used to create a notch at 787.76 MHz and thus improve the rejection of incoming signal at 787.76 MHz. The component values C1-L3-C3 are tuned so as to get optimal noise figure, input matching and band-13 2nd harmonic rejection.

As the industry inclines toward assembly miniaturization and also surface mount technology matures, there is a desire to have smaller and thinner components. This is especially the case with portable electronics where higher circuit density is desired. BGA925L6 has ultra small package with dimensions of 0.70mm x 1.1mm x 0.40mm and it requires only two components at its input, the capacitor at the input has to be used if a DC block is required and the inductor provides input matching. This reduces the application bill of materials and the PCB area thus making it an ideal solution for compact and cost-effective GNSS LNA. The output of the BGA925L6 is internally matched to 50 Ω, and a DC blocking capacitor is integrated on-chip, thus no external component is required at the output.

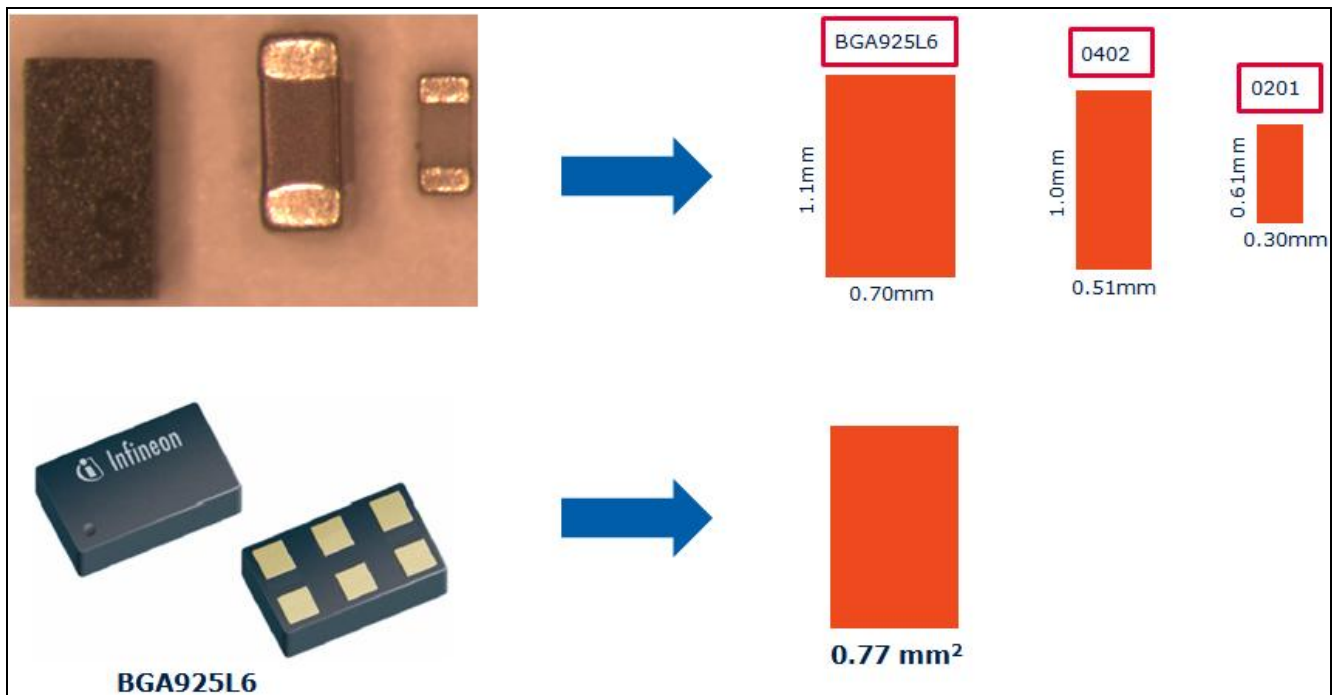

Figure 2 BGA925L6 package size in comparison with 0402 and 0201 components

¹ In this application note 0201 size SMDs are used. The noise figure of this application circuit can be further improved by using 0402 size inductor. For complete evaluation of this circuit please refer to AN267.

The device also integrates an on-chip ESD protection which can resist until 2 kV (referenced to Human Body Model). The integrated power on/off feature provides for low power consumption and increased stand-by time for GNSS handsets. Moreover, the low current consumption (4.8 mA) makes the device suitable for portable technology like GNSS receivers and mobiles phones.

The internal circuit diagram of the BGA925L6 is presented in Figure 3. Table 3 shows the pin assignment of BGA925L6. Table 4 shows the truth table to turn on/off BGA925L6 by applying different voltage to the PON pin.

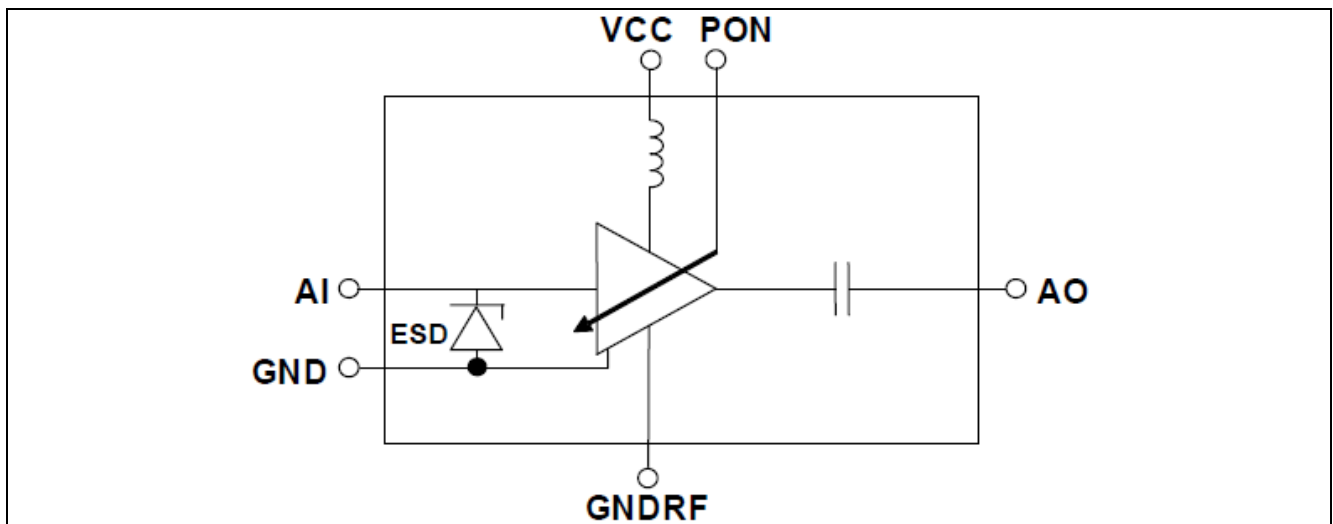

Figure 3 Block diagram of the BGA925L6 for GNSS band 1559-1615MHz applications

Table 3 Pin Definition

Pin	Symbol	Comment
1	GND	General ground
2	VCC	DC supply
3	AO	LNA output
4	GNDRF	LNA RF ground
5	AI	LNA input
6	PON	Power on control

Table 4 Switching Mode

Mode	Symbol	ON/OFF Control Voltage	
		Min	Max
On	PON, on	1.0V	VCC
Off	PON, off	0 V	0.4 V

3 Application Circuit

3.1 Schematic Diagram

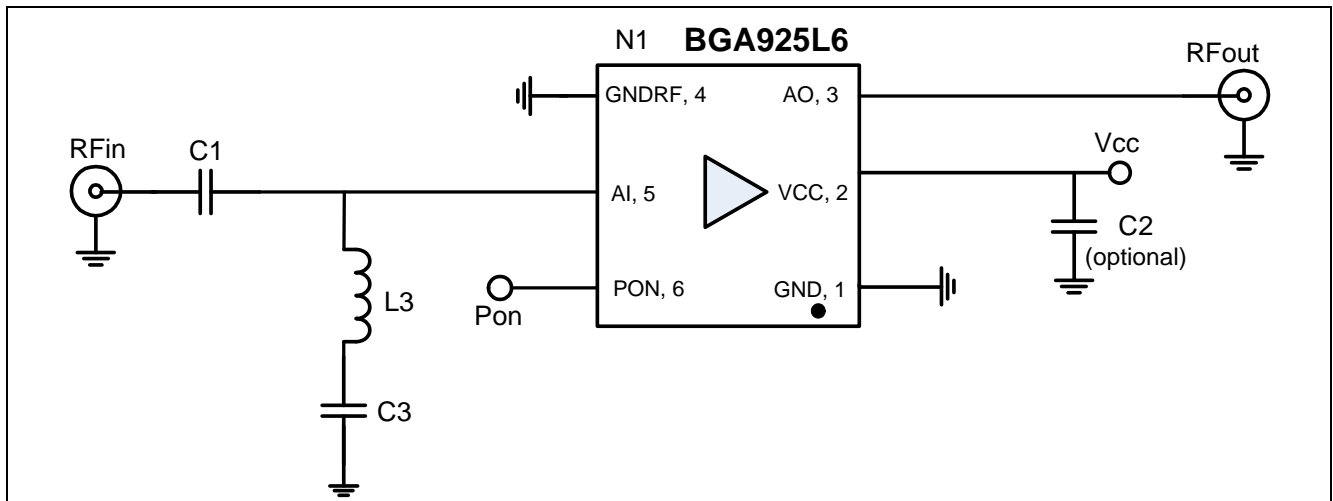

Figure 4 BGA925L6 application circuit

Table 5 Bill-of-Materials

Symbol	Value	Unit	Package	Manufacturer	Comment
C1	2	pF	0201	Various	DC block/Input matching
C2 (optional)	10	nF	0201	Various	RF bypass
L3	5.6	nH	0201	Murata LQP series	Input matching
C3	6.8	pF	0201	Various	Input matching
N1	BGA925L6		TSLP-6-2	Infineon	SiGe:C LNA
PCB substrate	FR4				

4 Typical Measurement Results

Table 6 and Table 7 show typical measurement results of the application circuit shown in Figure 4. The values given in this table include losses of the board and the SMA connectors if not otherwise stated.

Table 6 Electrical Characteristics (at room temperature), Vcc = Vpon = 1.8 V

Parameter	Symbol	Value			Unit	Comment/Test Condition
DC Voltage	Vcc	1.8			V	
DC Current	Icc	4.8			mA	
Navigation System	Sys	COMPASS/ Galileo	GPS	GLONASS		
Frequency Range	Freq	1559-1593	1575.42	1598-1606	MHz	
Gain	G	15.4	15.4	15.3	dB	
Noise Figure	NF	0.97	0.97	0.96	dB	PCB and SMA connectors of 0.1 dB losses subtracted
Input Return Loss	RLin	13.3	12.9	12.2	dB	
Output Return Loss	RLout	20.2	22.1	26.7	dB	
Reverse Isolation	IRev	22.5	22.4	22.3	dB	
Input P1dB	IP1dB	-9.9	-9.3	-9.3	dBm	f _{galileo} = 1559 MHz f _{gps} = 1575 MHz f _{GLONASS} = 1605 MHz
Output P1dB	OP1dB	4.5	5.1	5.0	dBm	
LTE band-13 2 nd Harmonic	H2 – input referred		-124.1		dBm	f _{IN} = 787.76 MHz, P _{IN} = -25 dBm f _{H2} = 1575.52 MHz
Input IP3 In-band	IIP3	-4.9	-4.9	-3.5	dBm	
Output IP3 In-band	OIP3	10.5	10.5	11.8	dBm	f _{1gal/gps} = 1575 MHz f _{2gal/gps} = 1576MHz f _{1GLONASS} =1602 MHz f _{2GLONASS} =1603 MHz Input power= -30dBm
Input IP3 out-of-band	IIP3 _{OOB}	8.0			dBm	f ₁ = 1712.7 MHz, P _{1IN} = -20 dBm f ₂ = 1850 MHz, P _{2IN} = -65 dBm f _{IIP3} = 1575.4 MHz
Stability	k	>1			--	Unconditionally Stable from 0 to 10GHz

Table 7 Electrical Characteristics (at room temperature), Vcc = Vpon = 2.8 V

Parameter	Symbol	Value			Unit	Comment/Test Condition
DC Voltage	Vcc	2.8			V	
DC Current	Icc	5.0			mA	
Navigation System	Sys	COMPASS/ Galileo	GPS	GLONASS		
Frequency Range	Freq	1559-1593	1575.42	1598-1606	MHz	
Gain	G	15.5	15.5	15.4	dB	
Noise Figure	NF	0.97	0.96	0.95	dB	PCB and SMA connectors of 0.1 dB losses subtracted
Input Return Loss	RLin	13.7	13.3	12.6	dB	
Output Return Loss	RLout	18.0	19.5	22.7	dB	
Reverse Isolation	IRev	22.9	22.9	22.7	dB	
Input P1dB	IP1dB	-9.6	-9.0	-8.9	dBm	f _{galileo} = 1559 MHz f _{gps} = 1575 MHz f _{GLONASS} = 1605 MHz
Output P1dB	OP1dB	4.9	5.5	5.5	dBm	
LTE band-13 2 nd Harmonic	H2 – input referred		-124.3		dBm	f _{IN} = 787.76 MHz, P _{IN} = -25 dBm f _{H2} = 1575.52 MHz
Input IP3 In-band	IIP3	-4.8	-4.8	-3.5	dBm	
Output IP3 In-band	OIP3	10.7	10.7	11.9	dBm	f _{1gal/gps} = 1575 MHz f _{2gal/gps} = 1576MHz f _{1GLONASS} =1602 MHz f _{2GLONASS} =1603 MHz Input power= -30dBm
Input IP3 out-of-band	IIP3 _{OOB}		8.1		dBm	f ₁ = 1712.7 MHz, P _{1IN} = -20 dBm f ₂ = 1850 MHz, P _{2IN} = -65 dBm f _{IIP3} = 1575.4 MHz
Stability	k		>1		--	Unconditionnally Stable from 0 to 10GHz

5 Measured Graphs for COMPASS, Galileo, GPS and GLONASS bands

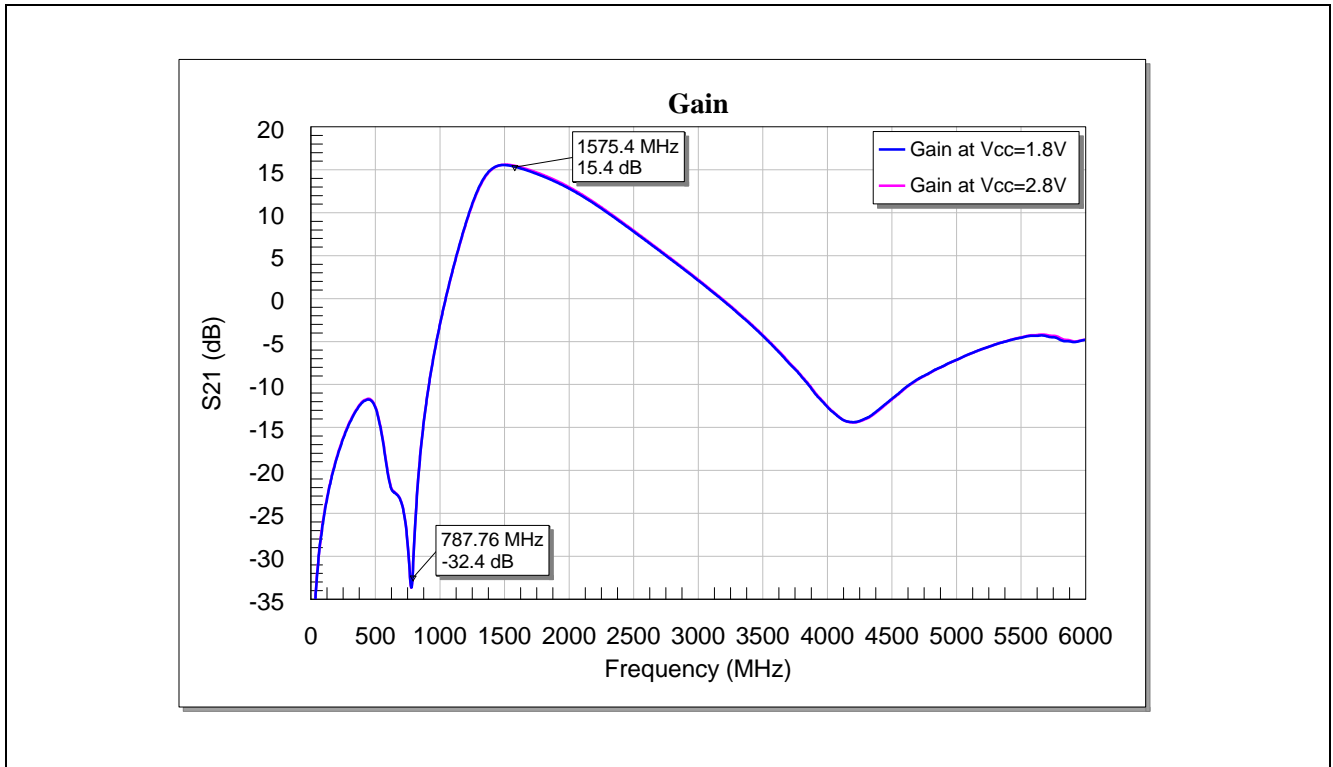

Figure 5 Power gain of BGA925L6 for COMPASS, Galileo, GPS and GLONASS bands

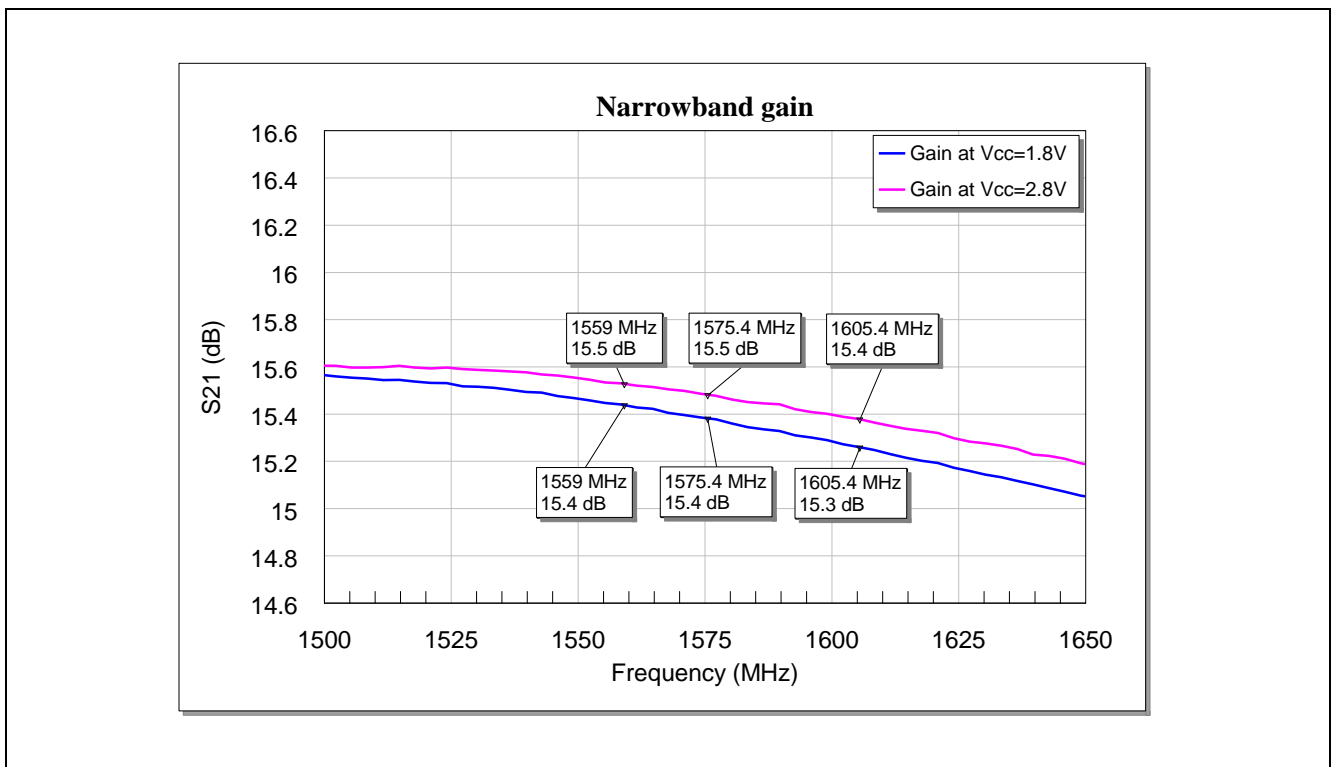

Figure 6 Narrowband power gain of BGA925L6 for COMPASS, Galileo, GPS and GLONASS bands

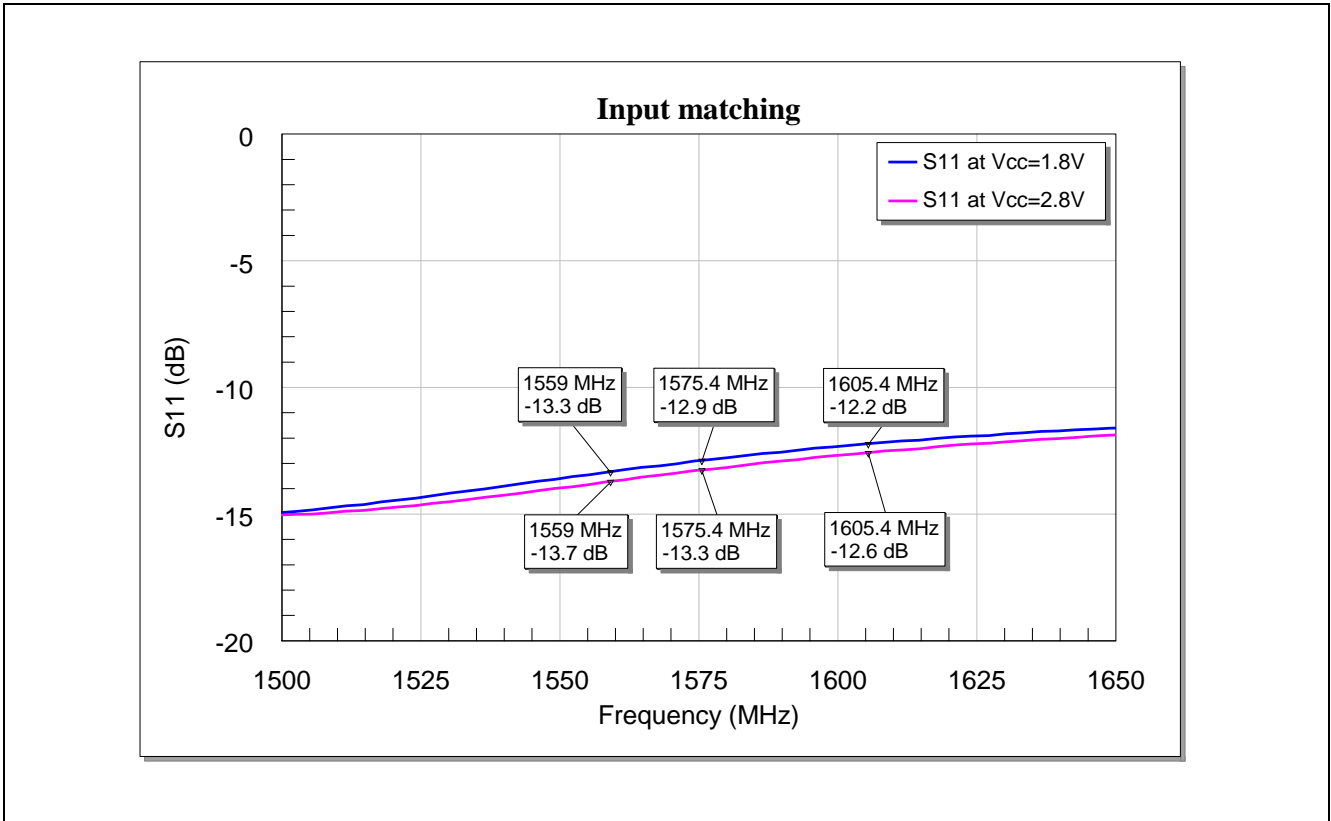

Figure 7 Input matching of BGA925L6 for COMPASS, Galileo, GPS and GLONASS bands

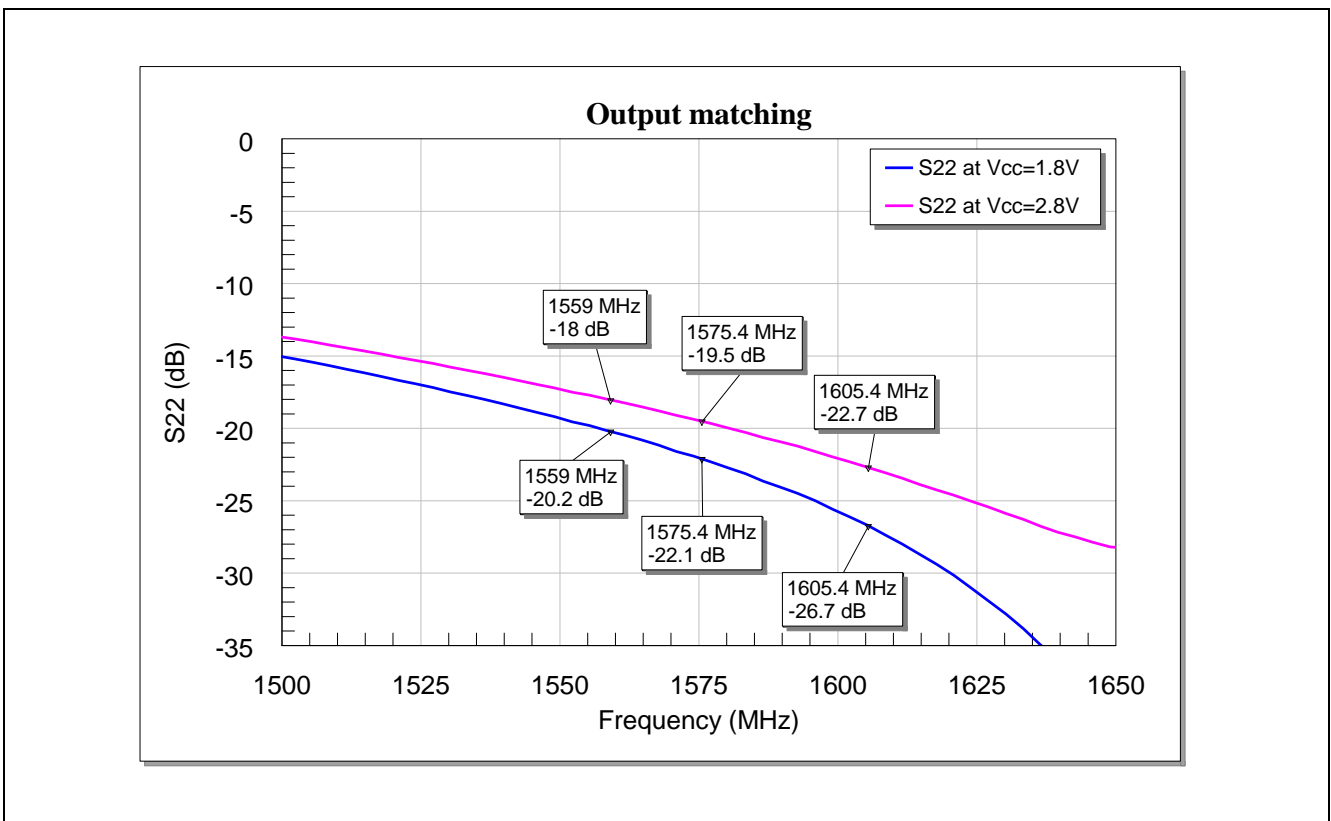

Figure 8 Output matching of BGA925L6 for COMPASS, Galileo, GPS and GLONASS bands

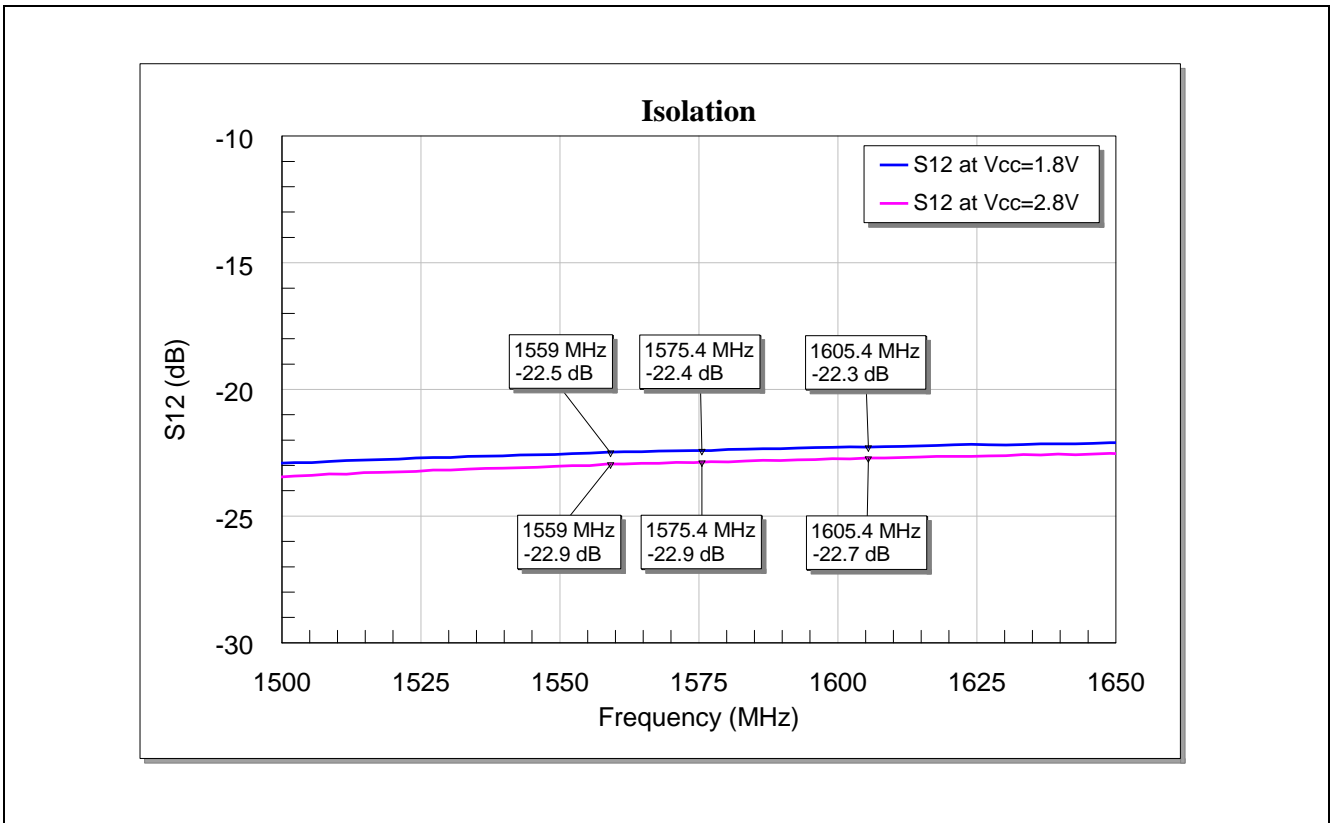

Figure 9 Reverse isolation of BGA925L6 for COMPASS, Galileo, GPS and GLONASS bands

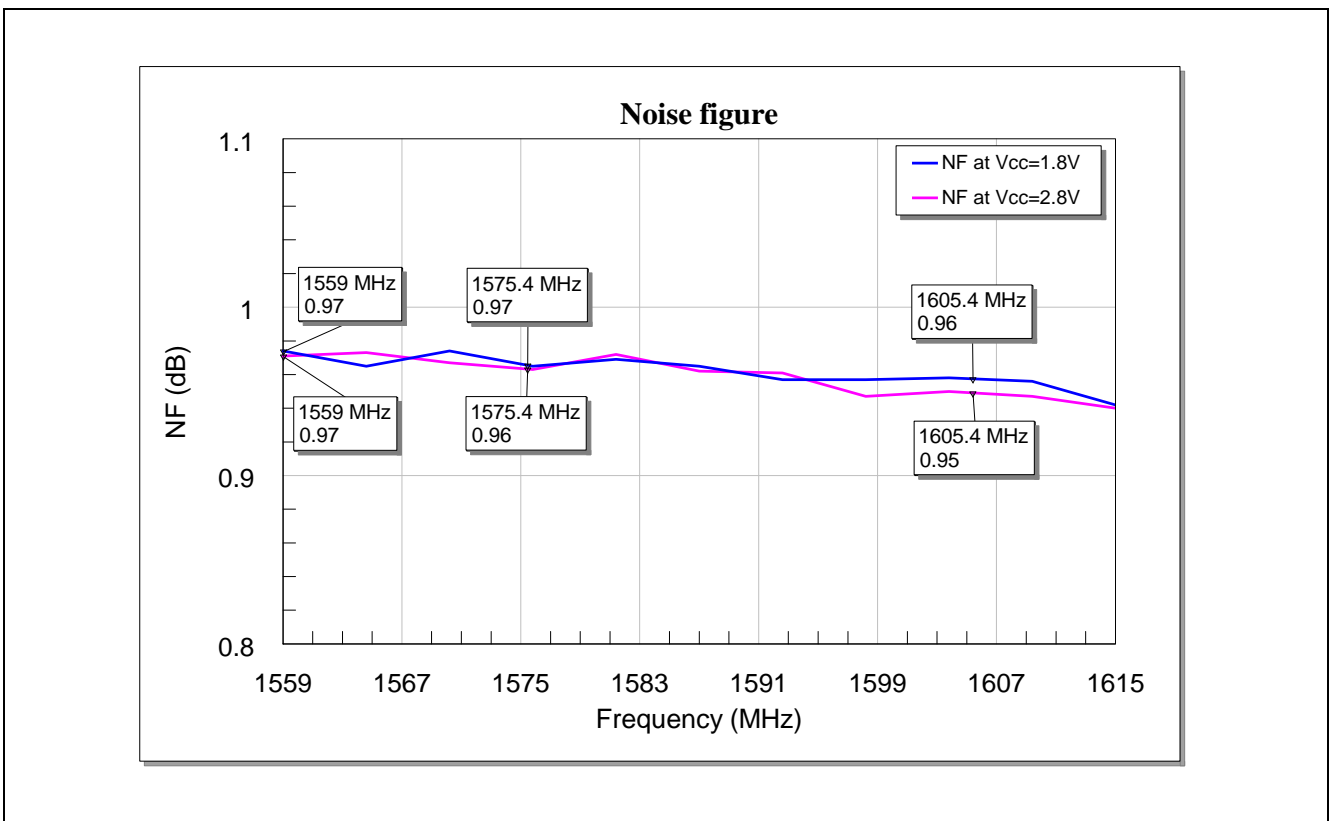

Figure 10 Noise figure of BGA925L6 for COMPASS, Galileo, GPS and GLONASS bands

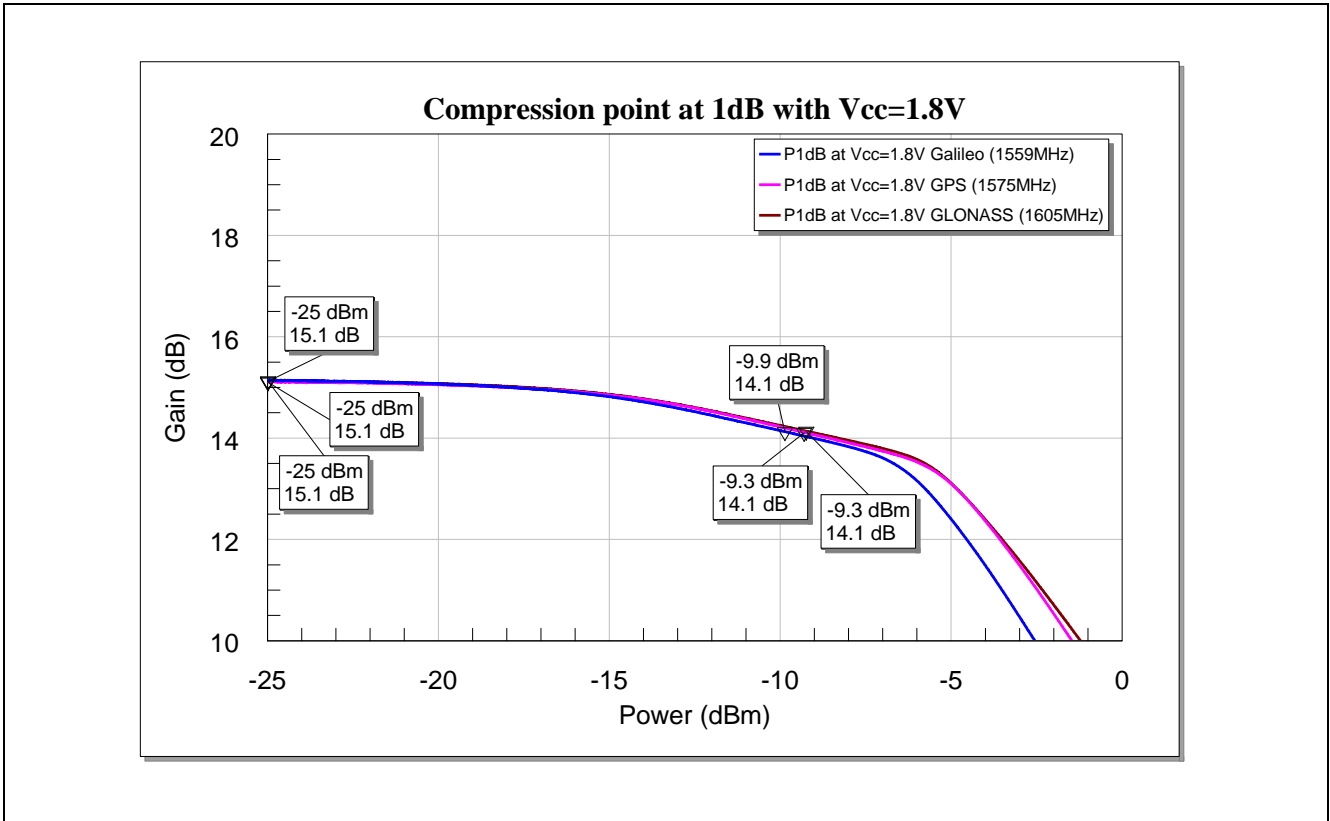

Figure 11 Input 1 dB compression point of BGA925L6 at supply voltage of 1.8V for COMPASS, Galileo, GPS and GLONASS bands

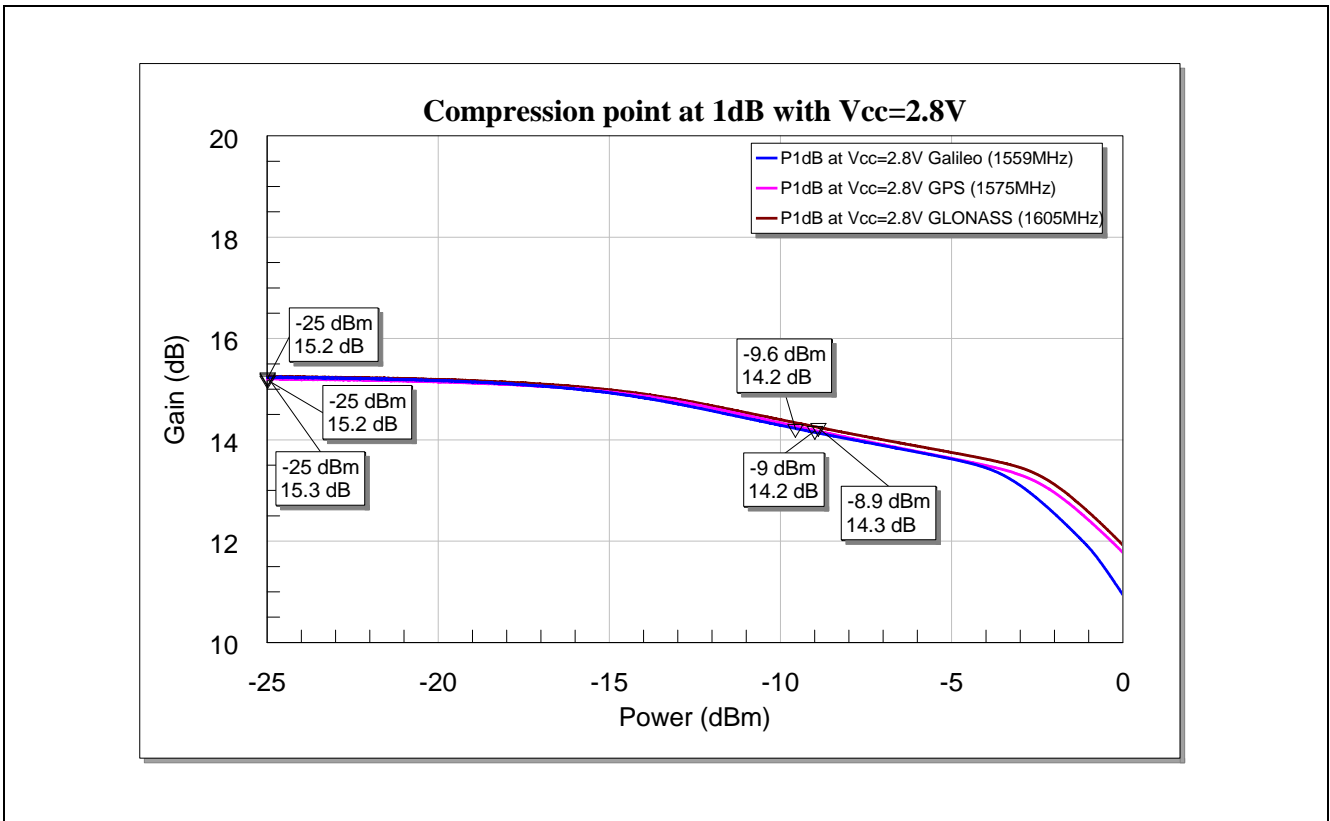

Figure 12 Input 1 dB compression point of BGA925L6 at supply voltage of 2.8V for COMPASS, Galileo, GPS and GLONASS bands

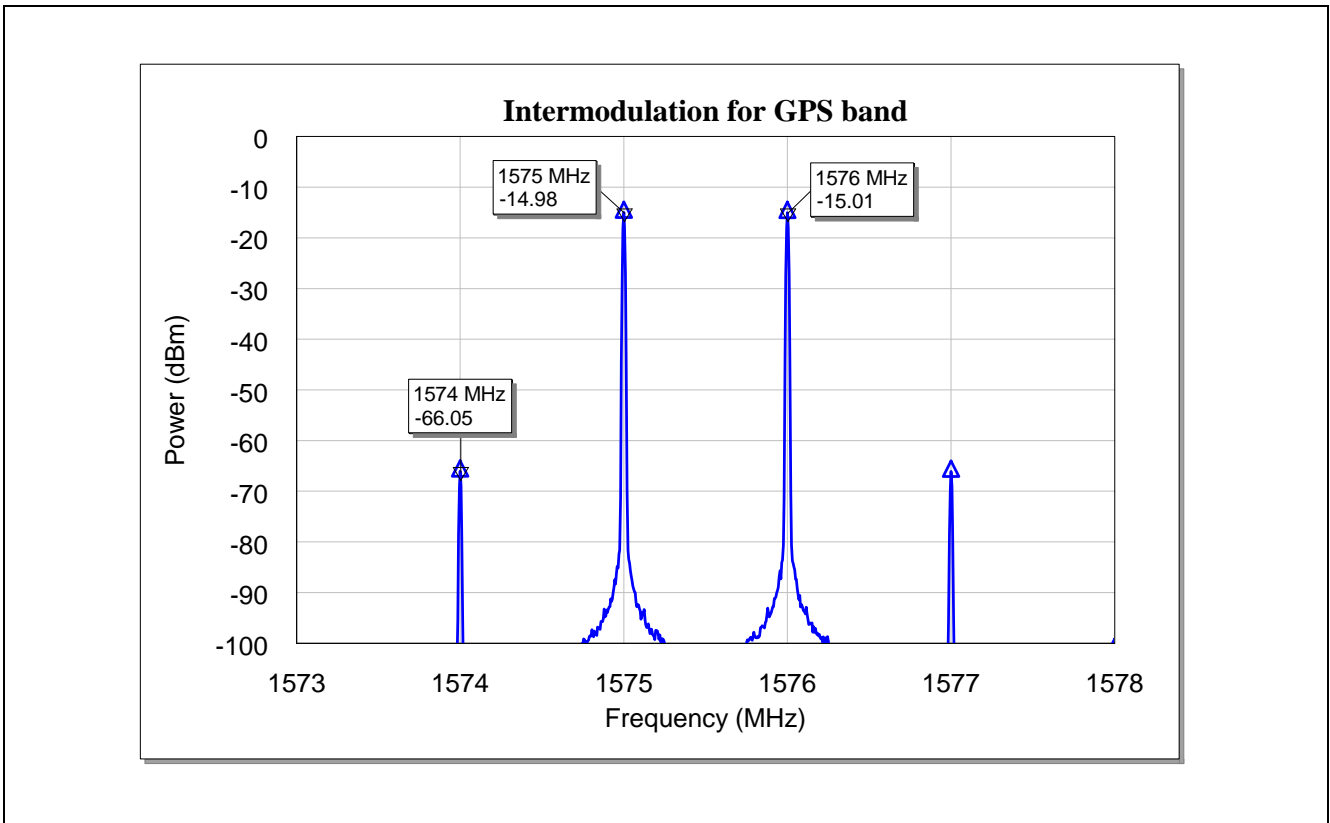

Figure 13 Carrier and intermodulation products of BGA925L6 for GPS band at Vcc=1.8V

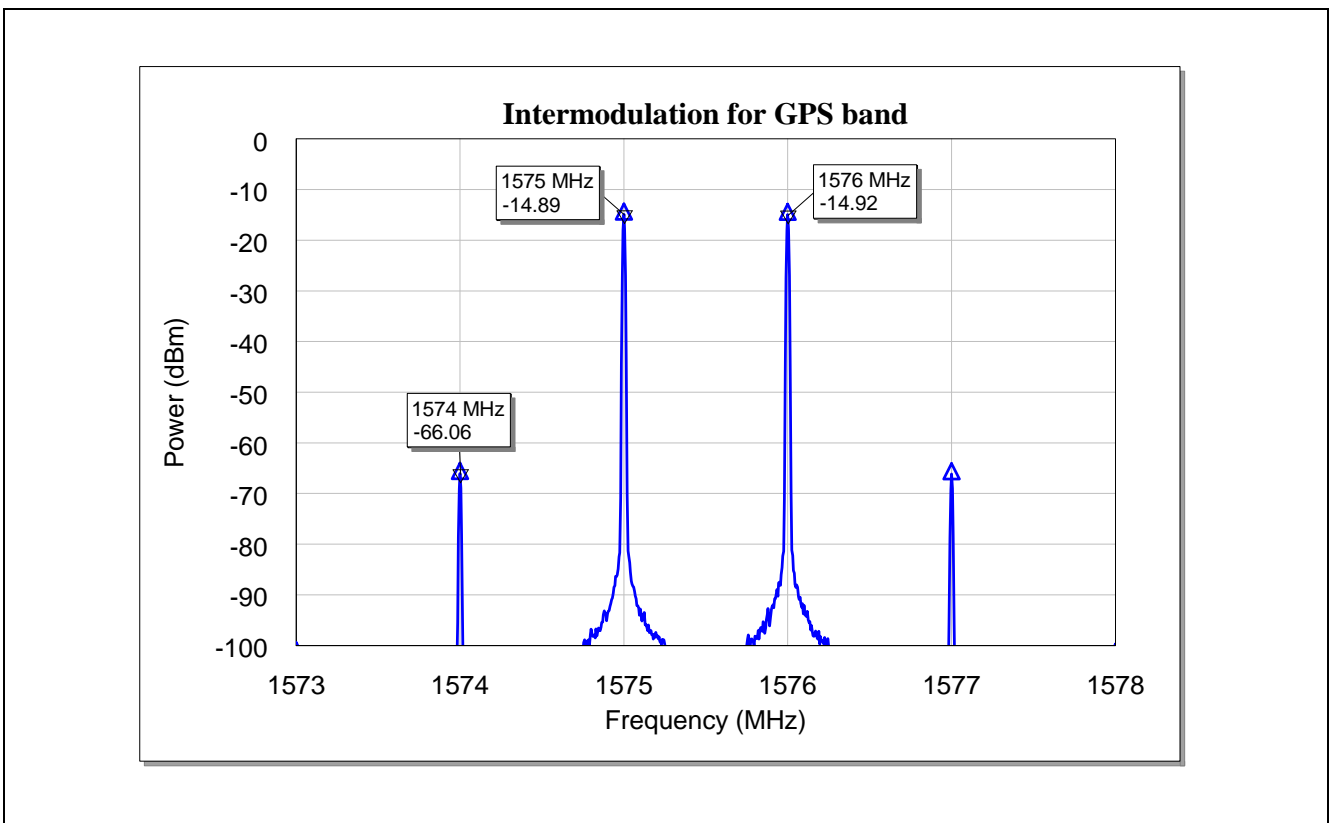

Figure 14 Carrier and intermodulation products of BGA925L6 for GPS band at Vcc=2.8V

6 Miscellaneous Measured Graphs

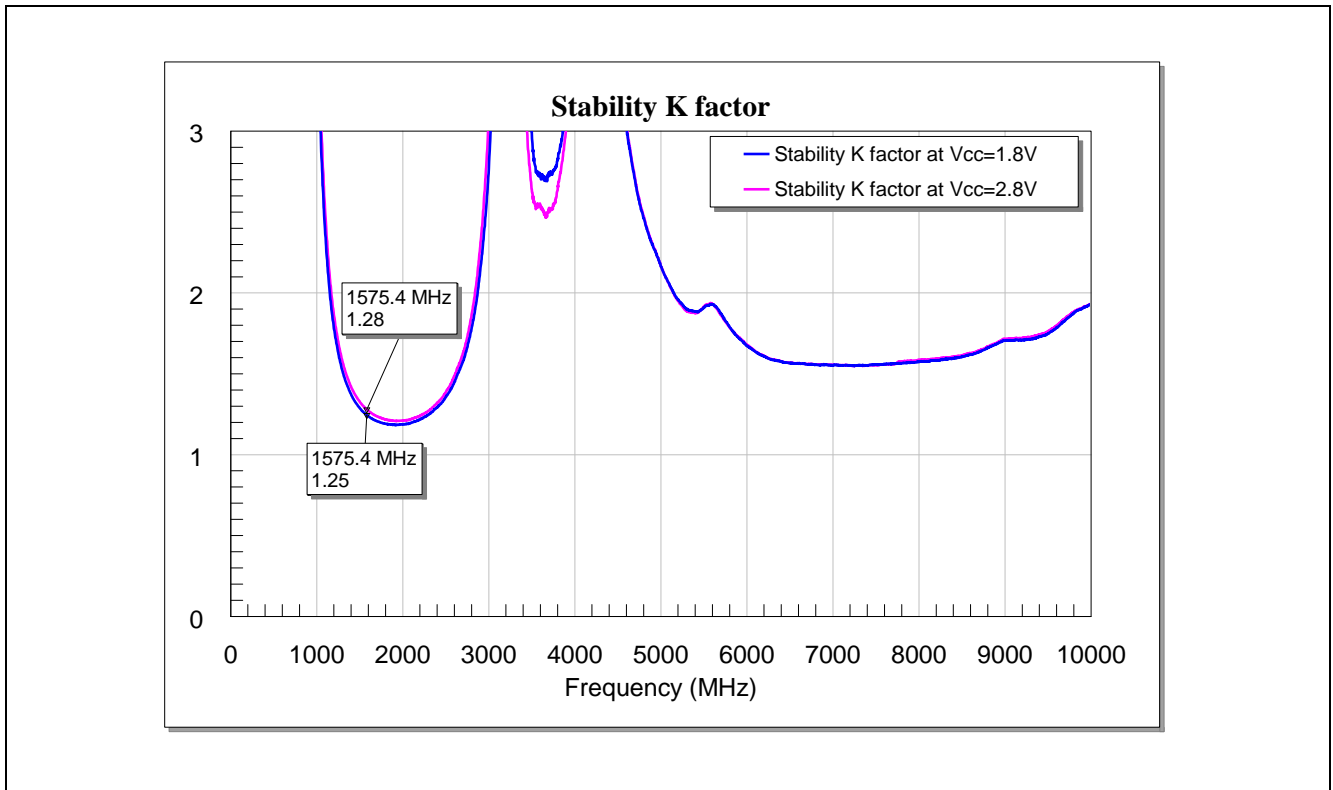

Figure 15 Stability factor k of BGA925L6 upto 10GHz

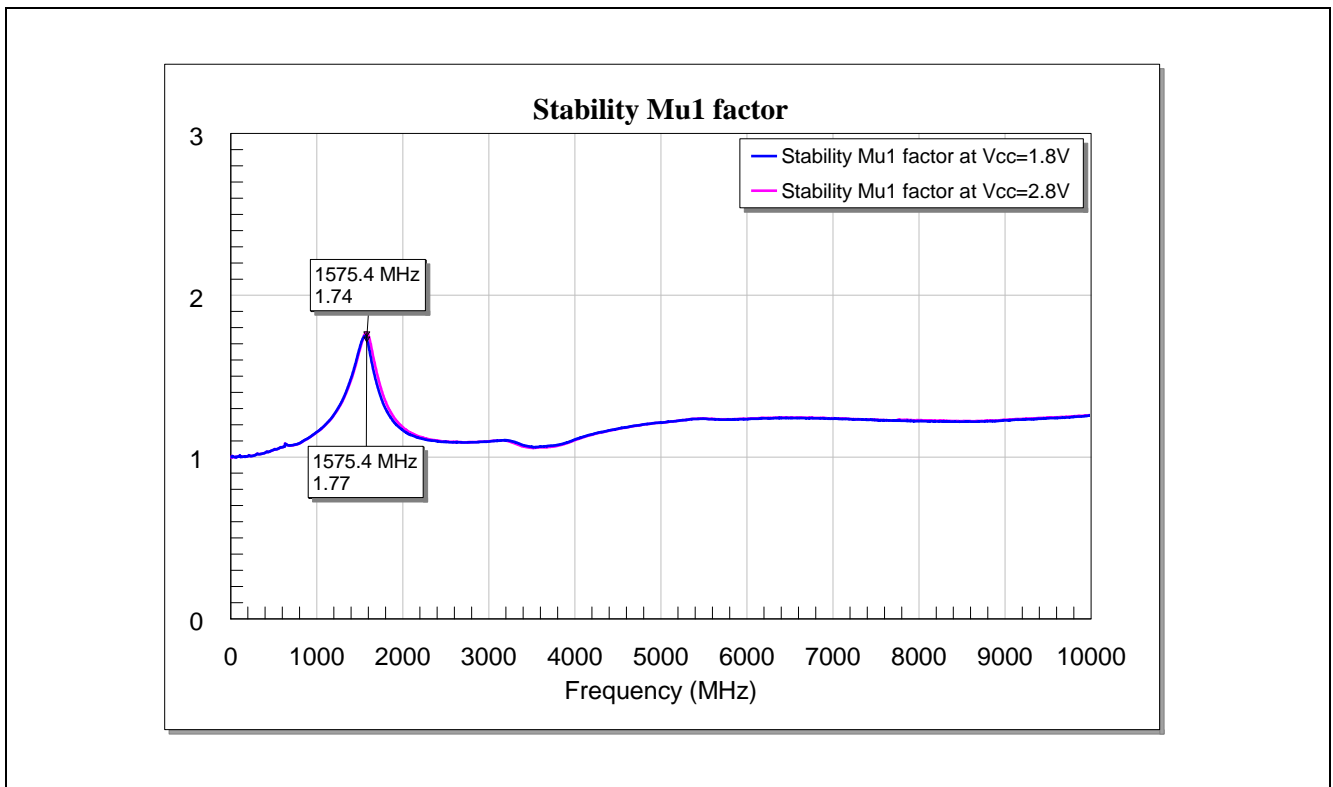

Figure 16 Stability factor μ_1 of BGA925L6 upto 10GHz

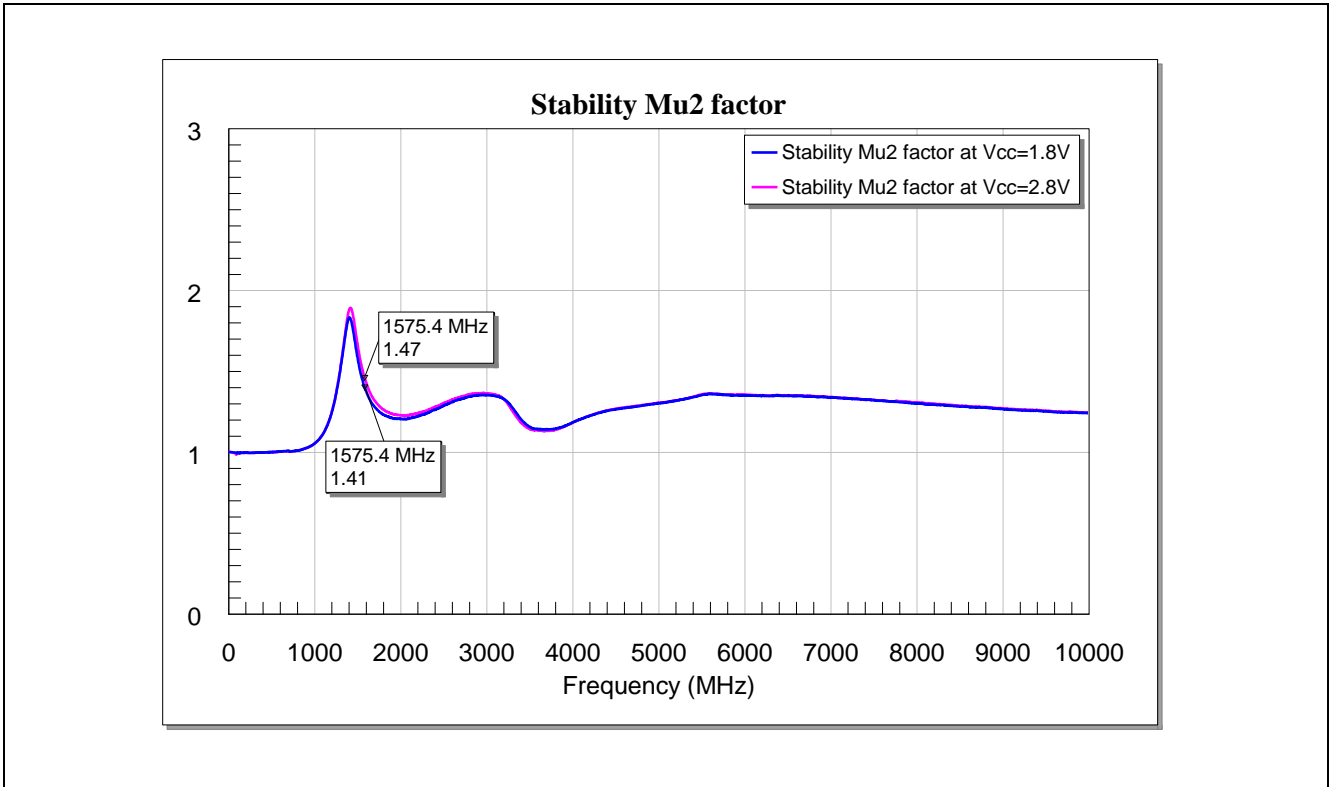

Figure 17 Stability factor μ_2 of BGA925L6 upto 10GHz

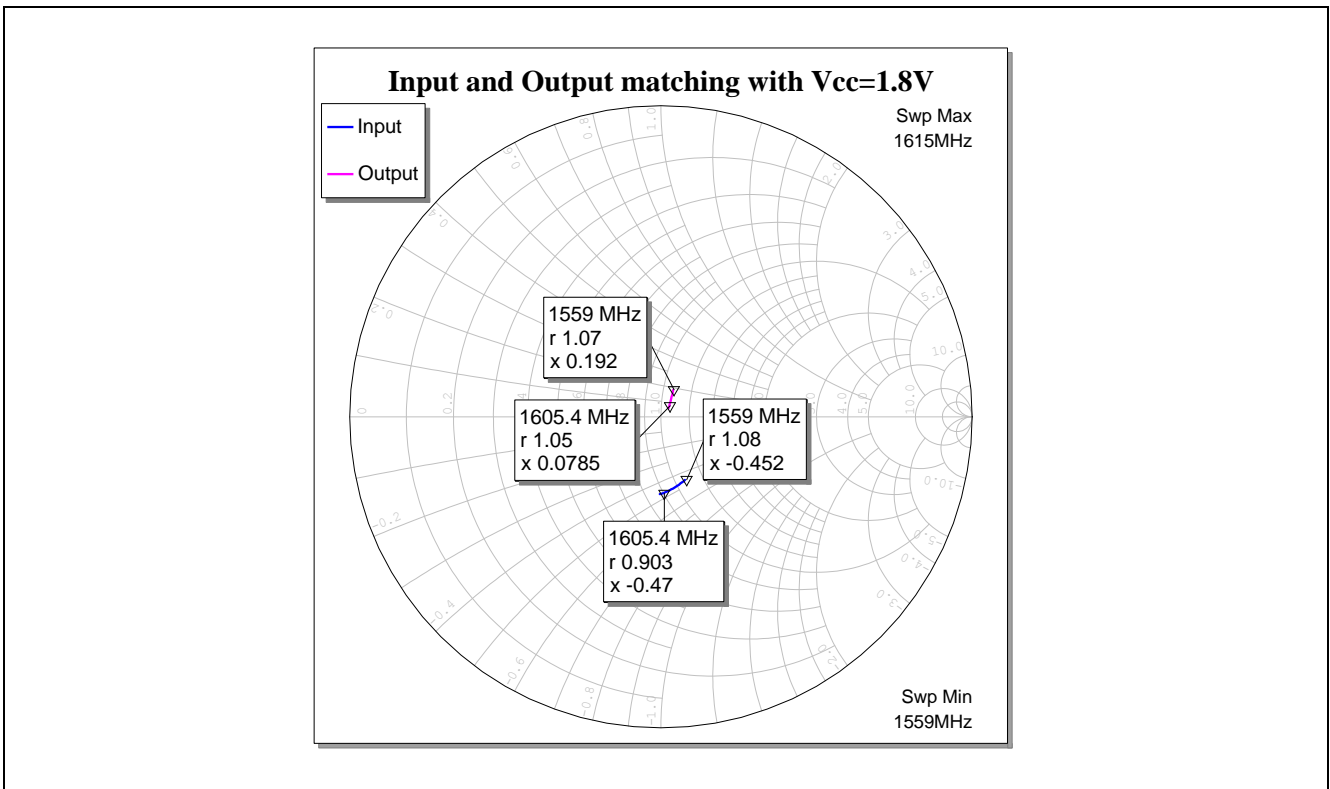

Figure 18 Input and output matching for COMPASS, Galileo, GPS and GLONASS bands with Vcc=1.8V

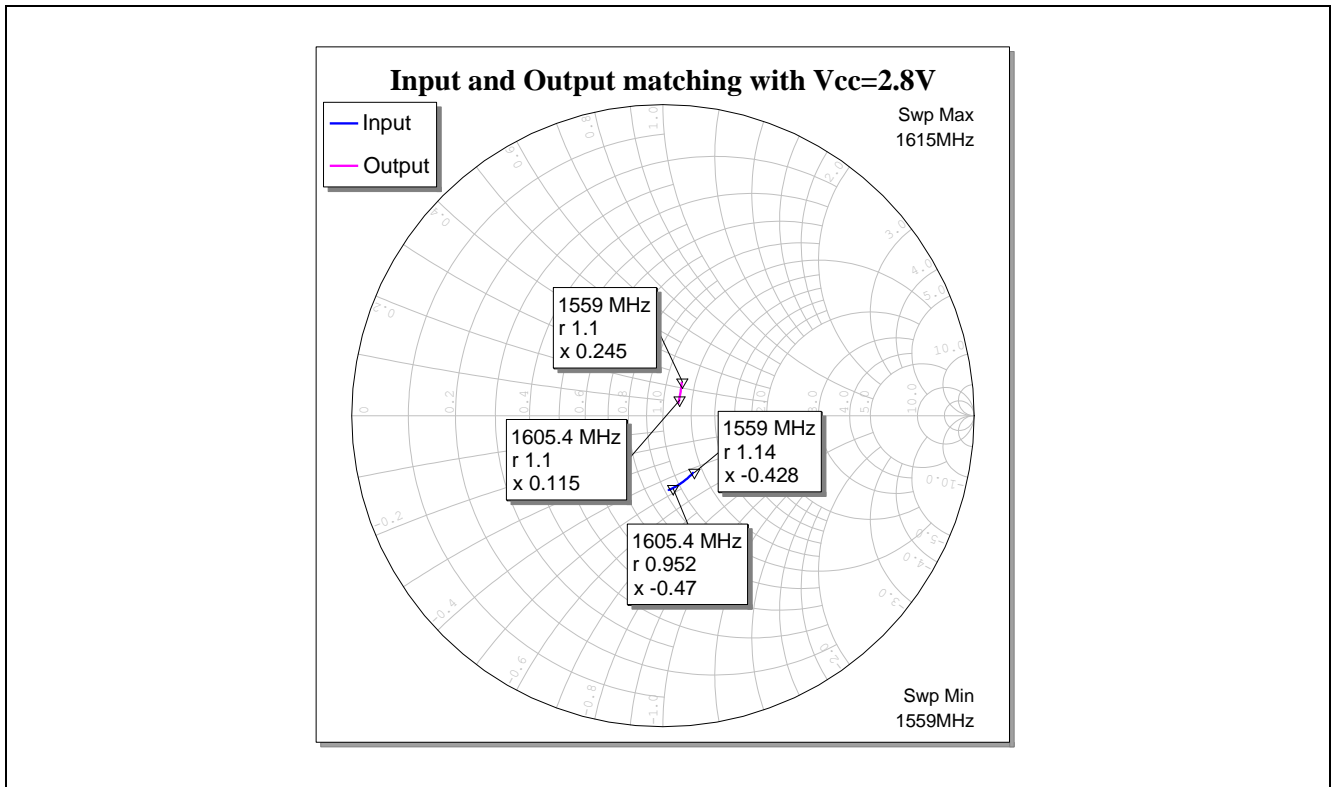

Figure 19 Input and output matching for COMPASS, Galileo, GPS and GLONASS bands with Vcc=2.8V

7 Evaluation Board

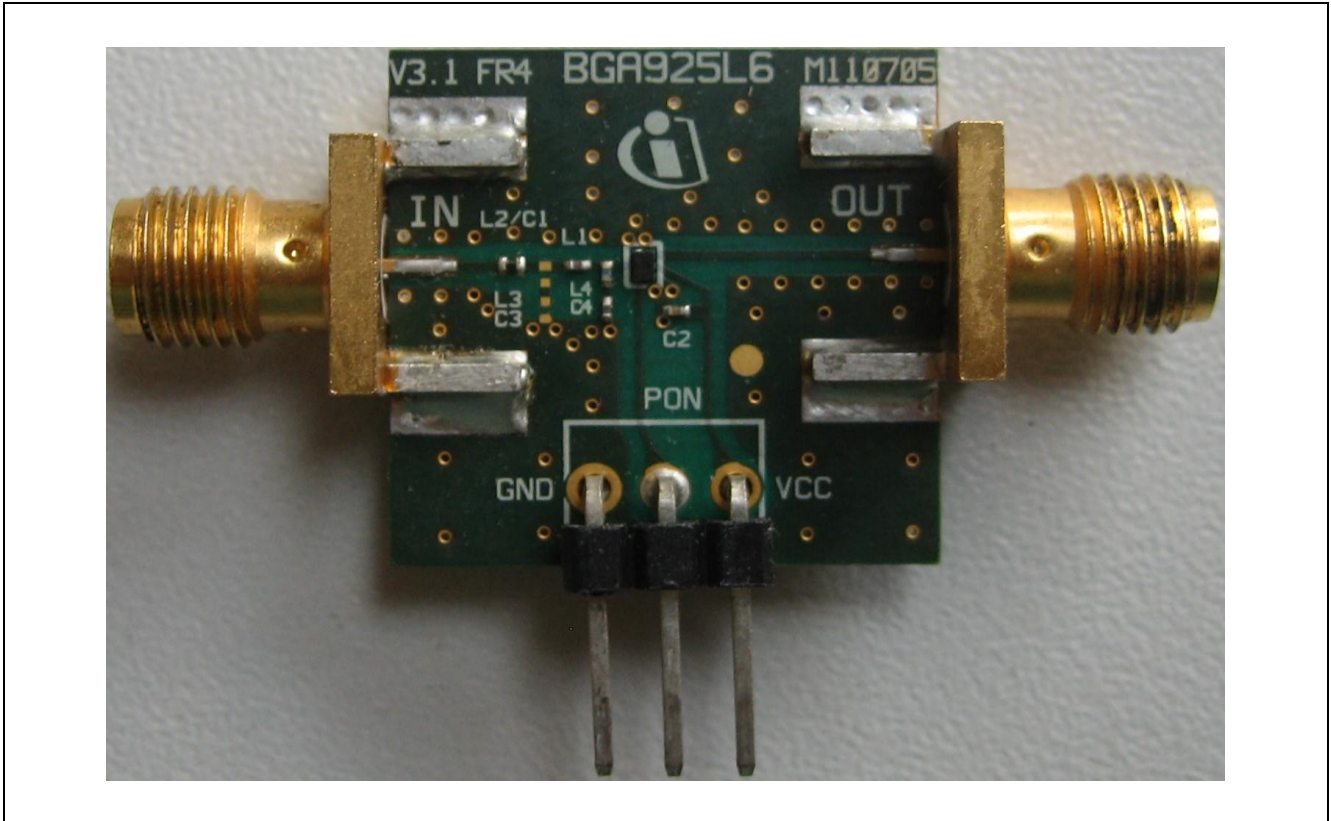

Figure 20 Populated PCB picture of BGA925L6

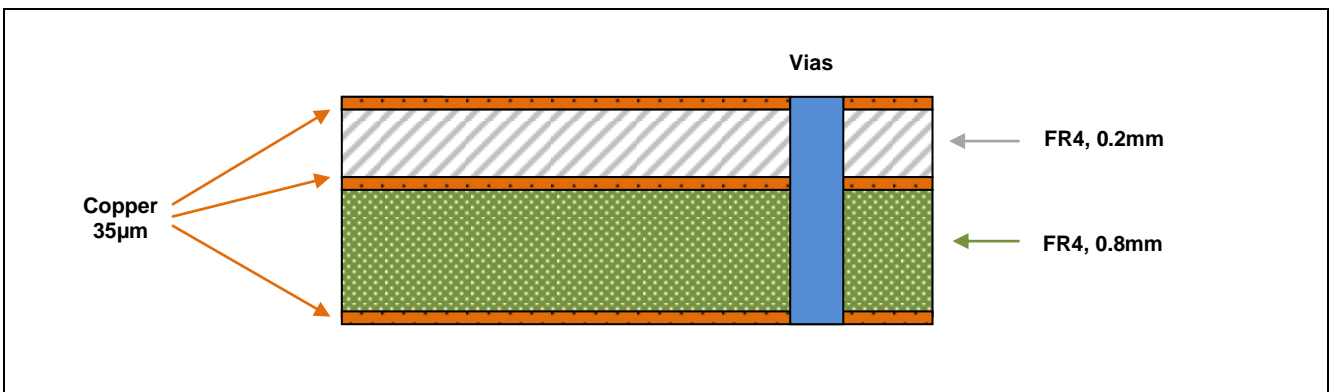

Figure 21 PCB layer stack

8 Authors

Jagjit Singh Bal, Senior Application Engineer of Business Unit “RF and Protection Devices”.
Dr. Chih-I Lin, Senior Staff Engineer of Business Unit “RF and Protection Devices”.

www.infineon.com