

# Application Note No. 095

Evaluation Report and Application Guide for Low-voltage capable RF MOSFET BF5030W

RF & Protection Devices



Never stop thinking

**Edition 2006-09-22**

**Published by  
Infineon Technologies AG  
81726 München, Germany**

**© Infineon Technologies AG 2009.  
All Rights Reserved.**

#### **LEGAL DISCLAIMER**

THE INFORMATION GIVEN IN THIS APPLICATION NOTE IS GIVEN AS A HINT FOR THE IMPLEMENTATION OF THE INFINEON TECHNOLOGIES COMPONENT ONLY AND SHALL NOT BE REGARDED AS ANY DESCRIPTION OR WARRANTY OF A CERTAIN FUNCTIONALITY, CONDITION OR QUALITY OF THE INFINEON TECHNOLOGIES COMPONENT. THE RECIPIENT OF THIS APPLICATION NOTE MUST VERIFY ANY FUNCTION DESCRIBED HEREIN IN THE REAL APPLICATION. INFINEON TECHNOLOGIES HEREBY DISCLAIMS ANY AND ALL WARRANTIES AND LIABILITIES OF ANY KIND (INCLUDING WITHOUT LIMITATION WARRANTIES OF NON-INFRINGEMENT OF INTELLECTUAL PROPERTY RIGHTS OF ANY THIRD PARTY) WITH RESPECT TO ANY AND ALL INFORMATION GIVEN IN THIS APPLICATION NOTE.

#### **Information**

For further information on technology, delivery terms and conditions and prices please contact your nearest Infineon Technologies Office ([www.infineon.com](http://www.infineon.com)).

#### **Warnings**

Due to technical requirements components may contain dangerous substances. For information on the types in question please contact your nearest Infineon Technologies Office.

Infineon Technologies Components may only be used in life-support devices or systems with the express written approval of Infineon Technologies, if a failure of such components can reasonably be expected to cause the failure of that life-support device or system, or to affect the safety or effectiveness of that device or system. Life support devices or systems are intended to be implanted in the human body, or to support and/or maintain and sustain and/or protect human life. If they fail, it is reasonable to assume that the health of the user or other persons may be endangered.

---

**Application Note No. 095**

**Revision History: 2006-09-22, Rev. 2.0**

**Previous Version:**

| <b>Page</b> | <b>Subjects (major changes since last revision)</b> |
|-------------|---|
| 4           | Bill of materials                                   |
| 7-17        | Measurement results                                 |
|             |   |
|             |   |
|             |   |
|             |   |
|             |   |
|             |   |
|             |   |

## Evaluation Report and Application Guide for Low-voltage capable RF MOSFET BF5030W

### 1 Introduction

Infineon's MOSFETs are ideally designed for pre-stage amplifier in TV and FM radio tuners, featuring low noise figure and high gain level. In order to accommodate demand for low voltage tuners in mobile applications, the MOSFETs BF5030W and BG5130R are designed to operate with supply voltages from 3 V to 5 V, rather than a typical operating voltage of 5 V

This application note provides information on how one can do performance measurements on the device by using Infineon's BF5030W Evaluation Board and summarizes some measurement results. Although the evaluation board is primarily intended to be used with the BF5030W, it may also be used for other MOSFETs.

Since terrestrial TV tuners have to cover frequency ranges from 45 MHz up to 860 MHz and the characteristic of the device changes with frequency, the evaluation board provides for two different configurations in order to achieve high performance for both low frequencies and high frequencies. While one configuration is designed for a frequency of 50 MHz, the other one is designed for a frequency of 800 MHz. For the purpose of measuring with standard measurement equipment, both configurations are designed for a 50  $\Omega$  system rather than a 75  $\Omega$  system that is commonly used in TV systems. Furthermore, a narrow-band matching is applied at the output in order to achieve high gain. Hence, the configurations described here are not suitable to be used for tuners. If you are interested in a reference design for a complete tuner, there are other applications notes available from Infineon that cover this topic.

For the purpose of making measurements of highest possible gain and lowest possible noise figure of MOSFETs, a fixture with mechanically tunable input and output matching was created by Infineon. Because such a fixture is not available to customers, an evaluation board was created for the purpose of enabling the customer to make measurements on the device without the necessity of having a fixture hand. Highest gain and lowest noise figure, as stated in the data sheet, cannot be met simultaneously, and therefore design goal for the evaluation board was to achieve a low noise figure and not the maximum available gain.

The MOSFET is inherently a potential unstable device, especially at higher frequencies, and therefore some stabilization circuitry must be applied in order to prevent oscillation. However, the principle task of a stabilization circuitry is to dissipate power and therefore unconditional stability was not an essential design goal, but the stabilization circuitry is nonetheless designed in a satisfactory manner, so that oscillation will not occur if proper termination is ensured. Please note that the fixture, which is used for measurements relevant to the data sheet, does not include any stabilization circuitry.

### 2 The Evaluation Board

The evaluation board is made of a two layer board with FR4 laminate and has a thickness of 1 mm. To avoid crossing of RF ground tracks, the layout is arranged in such a manner that the power supply connector is placed at the board's center, while both configurations are rotated about the center against each other rather than being placed one below the other. Please be aware of this to not get mixed up when you measure both configurations at the same time.

The Infineon MOSFET BF5030W is a tetrode, i.e. a dual-gate MOSFET that features semibiassing. While one gate (G1) is connected to the RF input the other gate (G2) is intended for automatic gain control (AGC). The AGC-pin is connected through the 3-pin power supply connector. BF5030W is a semi-biased MOSFET, which has part of the DC-biasing resistor network, integrated, and is designed for tuner ICs with PNP band-switch ports such as TUA6034, TUA6039, TUA6041 and TUA6045.

Reverse isolation of the MOSFET will be increased if a capacitor of at least 1 nF capacitance is placed as close as possible next to gate two (G2). This is not only true for the evaluation board but also for tuners. On the

## The Evaluation Board Evaluation Report and Application Guide for Low-

evaluation board these capacitors are designated as C5 and C14, respectively. Because of the extremely low leakage current of at most 50 nA at gate two (G2), a high resistor value of 100 kΩ can be used for RF blocking (R2 and R4). However, for automatic gain control in a tuner a suitable time constant has to be taken into account as well, and therefore a lower resistance value may be advisable.

**Figure 1** shows the layout diagram of the evaluation board, which has a dimension of 30 mm x 50 mm, and one can see a photo of the populated evaluation board in **Figure 2**. The schematic are shown in **Figure 3** and **Figure 4**, respectively, and the bill of materials is listed in **Figure 1**. The bill of materials allows for two different supply voltages, 3 V and 5 V, respectively, with each consuming 10 mA of current per configuration, i.e. drain current is always 10 mA.

Because the output characteristic of the BF5030W changes slightly with supply voltage, the 800 MHz configuration needs a slightly different output match for a supply voltage of 5 V in order to meet a resonance frequency of 800 MHz with such a narrow-band matching at the output.

**Table 1 Bill of Materials**

| Designator                               | Value   | Package | Function  |
|--|---------|---------|---|
| $C_1, C_2, C_8, C_9$                     | 22 nF   | 0603    | RF bypass   |
| $C_3$                                    | 22 nF   | 0603    | DC block  |
| $C_4$                                    | 15 pF   | 0603    | Input Matching  |
| $C_5, C_{14}$                            | 10 nF   | 0603    | Stabilization   |
| $C_6$                                    | 11 pF   | 0603    | Output matching and stabilization at high frequencies |
| $C_7$                                    | 8 pF    | 0603    | Output matching                                       |
| $C_{10}, C_{11}, C_{13}, C_{19}, C_{20}$ | 10 nF   | 0603    | RF bypass   |
| $C_{12}, C_{17}$                         | 56 pF   | 0603    | DC block  |
| $C_{15}$                                 | 0.5 pF  | 0603    | Output matching and stabilization at high frequencies |
| $C_{16}$                                 | 3 pF    | 0603    | Output matching                                       |
| $C_{18}$                                 | 5 pF    | 0603    | Stabilization   |
| $L_1$                                    | 470 nH  | 0603    | Input matching  |
| $L_2$                                    | 1200 nH | 0603    | Output matching                                       |
| $L_3$                                    | 470 nH  | 0603    | RF choke  |
| $L_4$                                    | 12 nH   | 0603    | Input matching  |
| $L_5$                                    | 22 nH   | 0603    | Input matching  |
| $L_6$                                    |         | 0603    | Output matching                                       |
| $V_{CC} = 3\text{ V}$                    | 30 nH   |         |   |
| $V_{CC} = 5\text{ V}$                    | 36 nH   |         |   |
| $L_7$                                    |         |         | RF choke and stabilization                            |
| $R_1, R_3$                               |         | 0603    | Biassing  |
| $V_{CC} = 3\text{ V}$                    | 82 kΩ   |         |   |
| $V_{CC} = 5\text{ V}$                    | 180 kΩ  |         |   |
| $R_2, R_4$                               |         |         | RF block  |
| $R_5$                                    |         | 0603    | Stabilization   |
| $V_{CC} = 3\text{ V}$                    | 15 Ω    |         |   |
| $V_{CC} = 5\text{ V}$                    | 10 Ω    |         |   |
| $T_1, T_2$                               | BF5030W | SOT343  | Infineon RF MOSFET                                    |

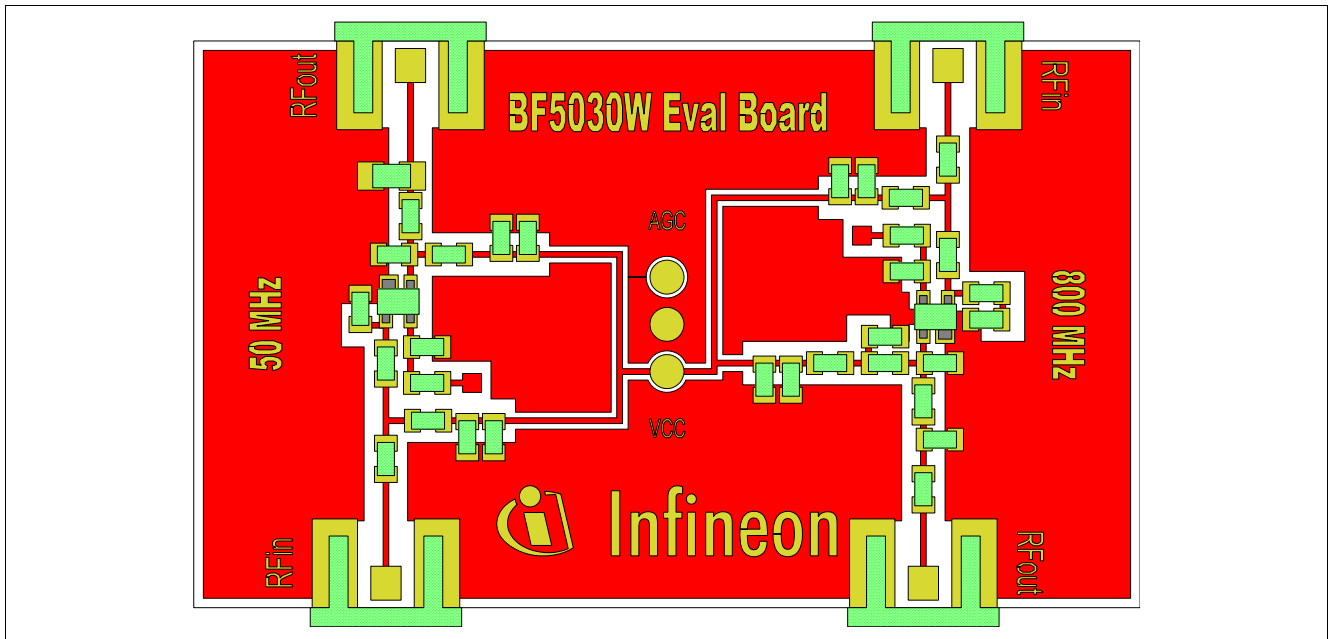

Figure 1 Layout Diagram of the Evaluation Board



Figure 2 Photo of the Evaluation Board

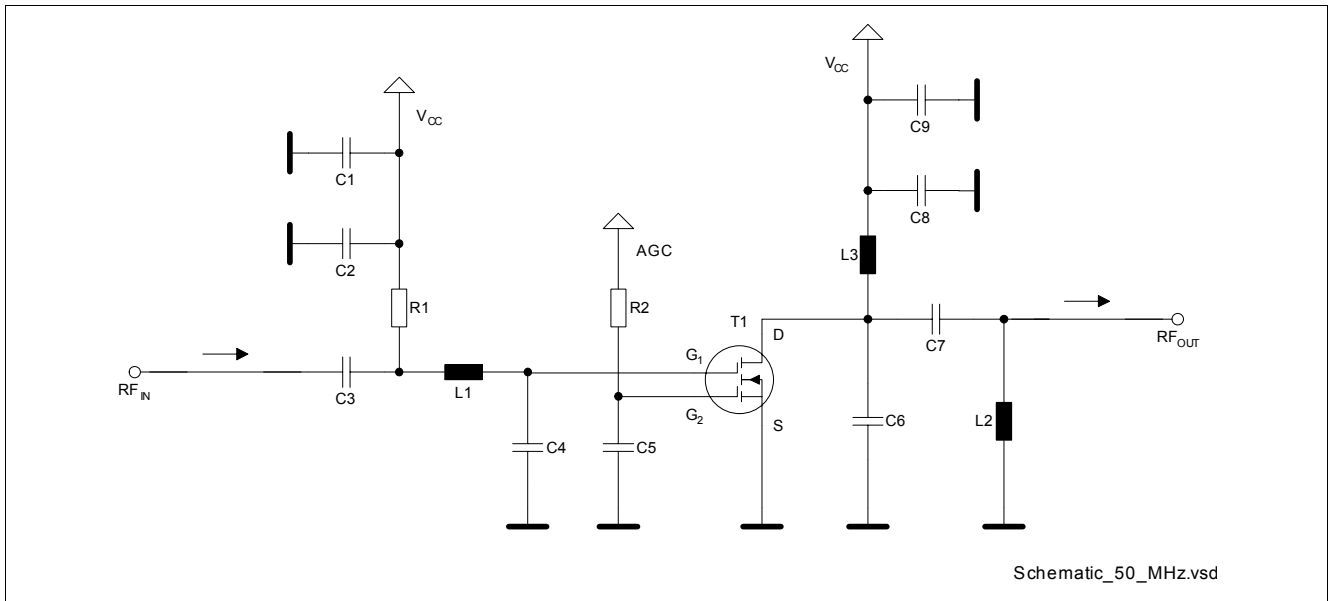

Figure 3 Schematic of 50 MHz Configuration

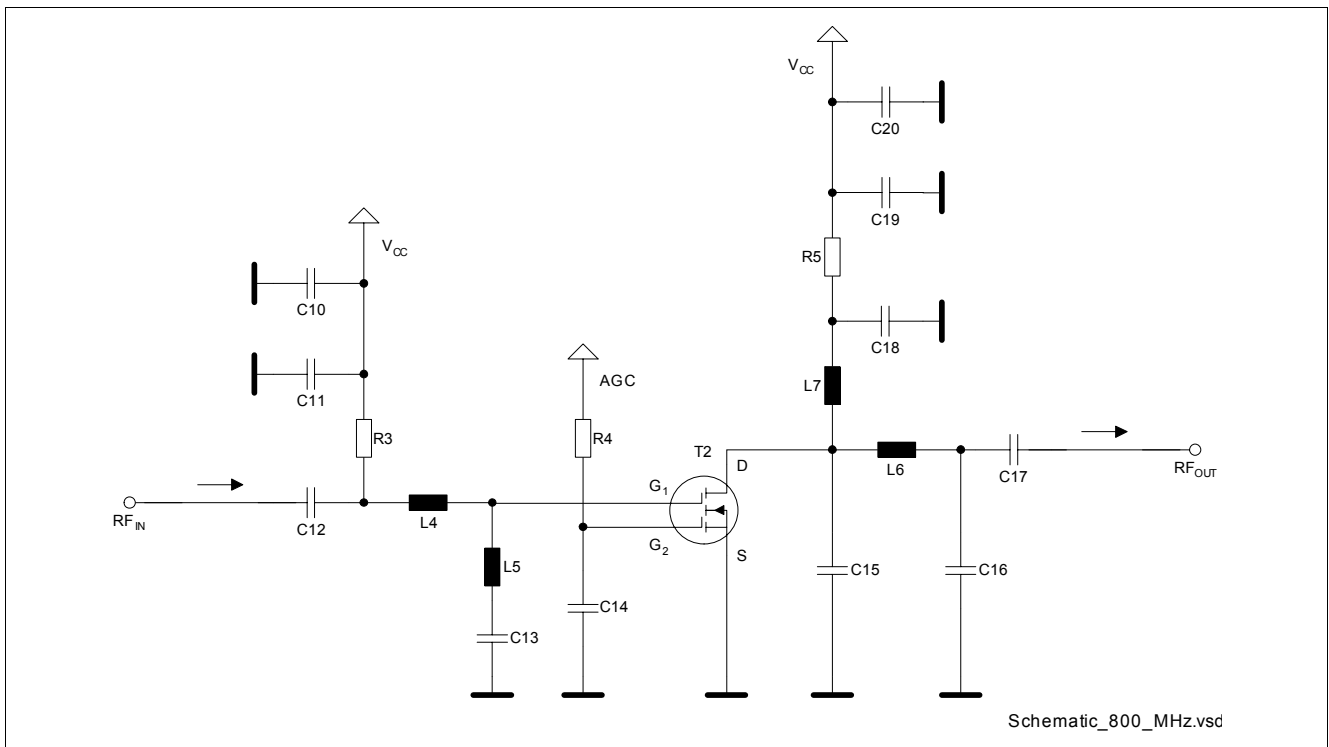

Figure 4 Schematic of 800 MHz Configuration

### 3 Measurement Results

The first measurement results presented in [Section 3.1](#) show the performance of Infineon's MOSFET BF5030W on the evaluation board for a supply voltage of 3 V. After this, in [Section 3.2](#), the measurement results for a supply voltage of 5 V are presented. Please note that the stated supply current refers to only one configuration i. e. if the evaluation board is populated for both configurations, the total supply current for the evaluation board will double.

#### 3.1 Assembly for 3 V Supply Voltage

Some key parameters are listed in [Table 3](#) and [Table 4](#), respectively, and are also shown in the form of graphs on [Page 10](#) and [Page 11](#). As mentioned above, input match is optimized for minimum noise figure and not maximum available gain, resulting in low input return losses of only 2 to 3 dB. To this end, some experiments were necessary and as a results of these experiments rough noise parameters for the BF5030W could be derived from a couple of measurements, which are listed in [Table 2](#). Please note that the noise parameters are not measured directly with a noise parameter measurement system and therefore we do not claim complete accuracy for the results listed in [Table 2](#).

A plot of the stability factor K is shown in [Figure 5](#) and [Figure 6](#), respectively, and one can see that the 50 MHz configuration is unconditionally stable over a frequency range between 1 MHz and 10 GHz. However, the 800 MHz configuration is on the brink of unconditional stability, but nonetheless, if both ports are terminated with an impedance of 50  $\Omega$ , oscillation will not occur.

**Table 2 Noise Parameter for BF5030W ( $V_{DS} = 3$  V,  $I_D = 10$  mA,  $V_{G2S} = 3$  V)**

| Parameter   | Symbol         | Value   | Unit     |
|---|----------------|---|----------|
| Minimum noise figure<br>$f = 50$ MHz<br>$f = 800$ MHz       | $NF_{min}$     | 0.7<br>1.6                                    | dB       |
| Optimum noise figure match<br>$f = 50$ MHz<br>$f = 800$ MHz | $\Gamma_{opt}$ | $0.8 \angle 7^\circ$<br>$0.7 \angle 87^\circ$ | –        |
| Noise resistance<br>$f = 50$ MHz<br>$f = 800$ MHz           | $R_n$          | 45<br>38                                      | $\Omega$ |

*Note: This board is designed for minimum noise figure and stable operation rather than maximum power gain*

**Table 3 Electrical Characteristics of 50 MHz Configuration**

| Parameter  | Symbol       | Value | Unit |
|--|--------------|-------|------|
| <b>DC Characteristics</b>                            |              |       |      |
| Supply voltage                                       | $V_{CC}$     | 3     | V    |
| Automatic gain control voltage                       | $V_{AGC}$    | 3     | V    |
| Supply current                                       | $I_{CC}$     | 10    | mA   |
| <b>AC Characteristics (verified by five samples)</b> |              |       |      |
| Power gain<br>$f = 50$ MHz                           | $ S_{21} ^2$ | 33    | dB   |
| Input return loss<br>$f = 50$ MHz                    | $RL_{in}$    | 2.8   | dB   |
| Output return loss<br>$f = 50$ MHz                   | $RL_{out}$   | 21    | dB   |



## Measurement Results Evaluation Report and Application Guide for Low-

**Table 3 Electrical Characteristics of 50 MHz Configuration (cont'd)**

| Parameter   | Symbol         | Value | Unit |
|---|----------------|-------|------|
| Reverse isolation<br>$f = 50$ MHz                                       | $1/ S_{12} ^2$ | 48    | dB   |
| Noise figure <sup>1)</sup><br>$f = 50$ MHz                              | $NF$           | 1.2   | dB   |
| 1 dB input compression point<br>$f = 50$ MHz                            | $IP_{1dB}$     | -35   | dBm  |
| Input third order intercept point<br>$f_1 = 49.5$ MHz, $f_2 = 50.5$ MHz | $IIP_3$        | -30   | dBm  |

1) Including SMA-connector and PCB losses of approximately 0.5 dB. Limited by these losses and different matching conditions, it is not possible to produce the same 50  $\Omega$  measurement environment as for the data sheet.

*Note: This board is designed for minimum noise figure and stable operation rather than maximum power gain*

**Table 4 Electrical Characteristics of 800 MHz Configuration**

| Parameter   | Symbol         | Value | Unit |
|---|----------------|-------|------|
| <b>DC Characteristics</b>   |                |       |      |
| Supply voltage  | $V_{CC}$       | 3     | V    |
| Automatic gain control voltage  | $V_{AGC}$      | 3     | V    |
| Supply current  | $I_{CC}$       | 10    | mA   |
| <b>AC Characteristics (verified by five samples)</b>                      |                |       |      |
| Power gain<br>$f = 800$ MHz   | $ S_{21} ^2$   | 20    | dB   |
| Input return loss<br>$f = 800$ MHz  | $RL_{in}$      | 2.7   | dB   |
| Output return loss<br>$f = 50$ MHz  | $RL_{out}$     | 22    | dB   |
| Reverse isolation<br>$f = 800$ MHz  | $1/ S_{12} ^2$ | 34    | dB   |
| Noise figure <sup>1)</sup><br>$f = 800$ MHz                               | $NF$           | 1.8   | dB   |
| 1 dB input compression point<br>$f = 800$ MHz                             | $IP_{1dB}$     | -21   | dBm  |
| Input third order intercept point<br>$f_1 = 799.5$ MHz, $f_2 = 800.5$ MHz | $IIP_3$        | -18   | dBm  |

1) Including SMA-connector and PCB losses of approximately 0.2 dB. Limited by these losses and different matching conditions, it is not possible to produce the same 50  $\Omega$  measurement environment as for the data sheet.

Measurement Results Evaluation Report and Application Guide for Low-

S-Parameters and Noise Figure of MHz of 50 MHz Configuration

**Matching**  $|S_{11}|, |S_{22}| = f(f)$   
 $V_{CC} = 3V, V_{AGC} = 3V, I_{CC} = 10mA$

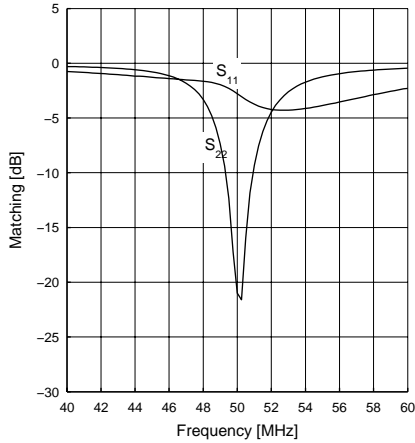

**Power Gain**  $|S_{21}|^2 = f(f)$   
 $V_{CC} = 3V, V_{AGC} = 3V, I_{CC} = 10mA$

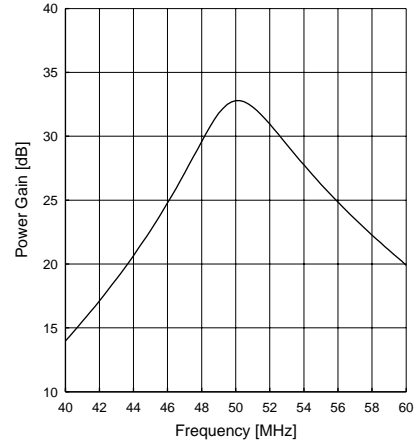

**Reverse Isolation**  $1/|S_{12}|^2 = f(f)$   
 $V_{CC} = 3V, V_{AGC} = 3V, I_{CC} = 10mA$

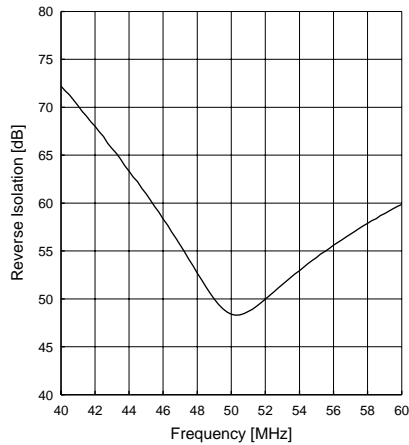

**Noise Figure**  $NF = f(f)$   
 $V_{CC} = 3V, V_{AGC} = 3V, I_{CC} = 10mA$

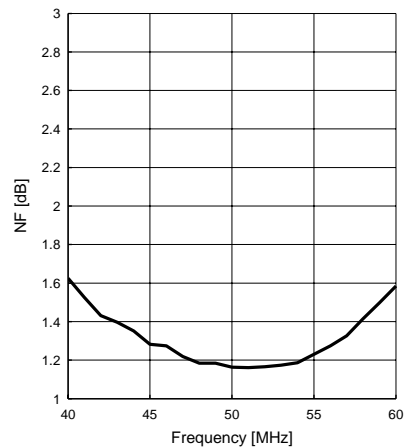

Measurement Results Evaluation Report and Application Guide for Low-

S-Parameters and Noise Figure of MHz of 800 MHz Configuration

**Matching**  $|S_{11}|, |S_{22}| = f(f)$   
 $V_{CC} = 3V, V_{AGC} = 3V, I_{CC} = 10mA$

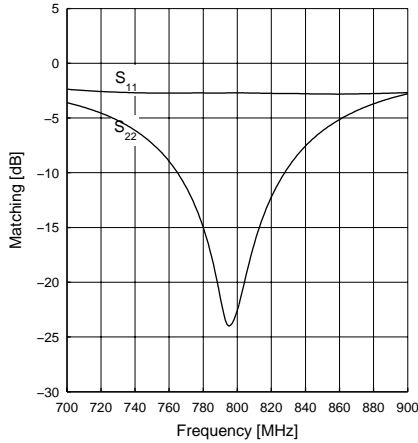

**Power Gain**  $|S_{21}|^2 = f(f)$   
 $V_{CC} = 3V, V_{AGC} = 3V, I_{CC} = 10mA$

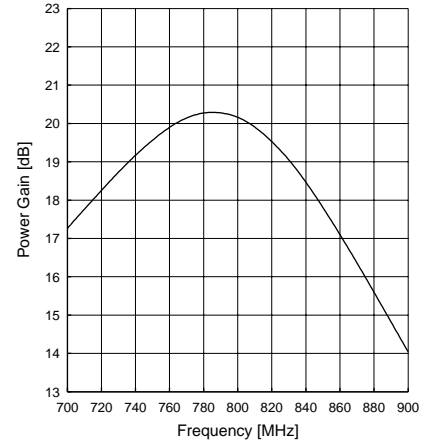

**Reverse Isolation**  $1/|S_{12}|^2 = f(f)$   
 $V_{CC} = 3V, V_{AGC} = 3V, I_{CC} = 10mA$

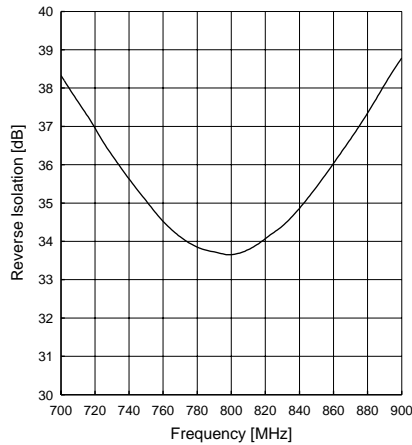

**Noise Figure**  $NF = f(f)$   
 $V_{CC} = 3V, V_{AGC} = 3V, I_{CC} = 10mA$

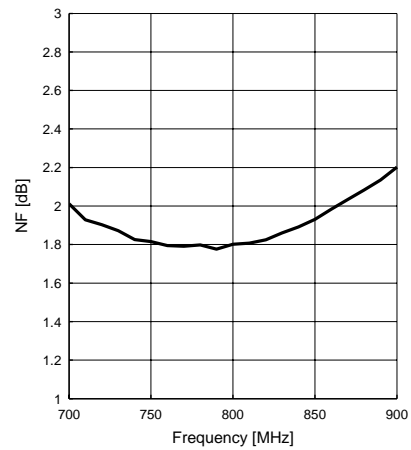

Measurement Results Evaluation Report and Application Guide for Low-

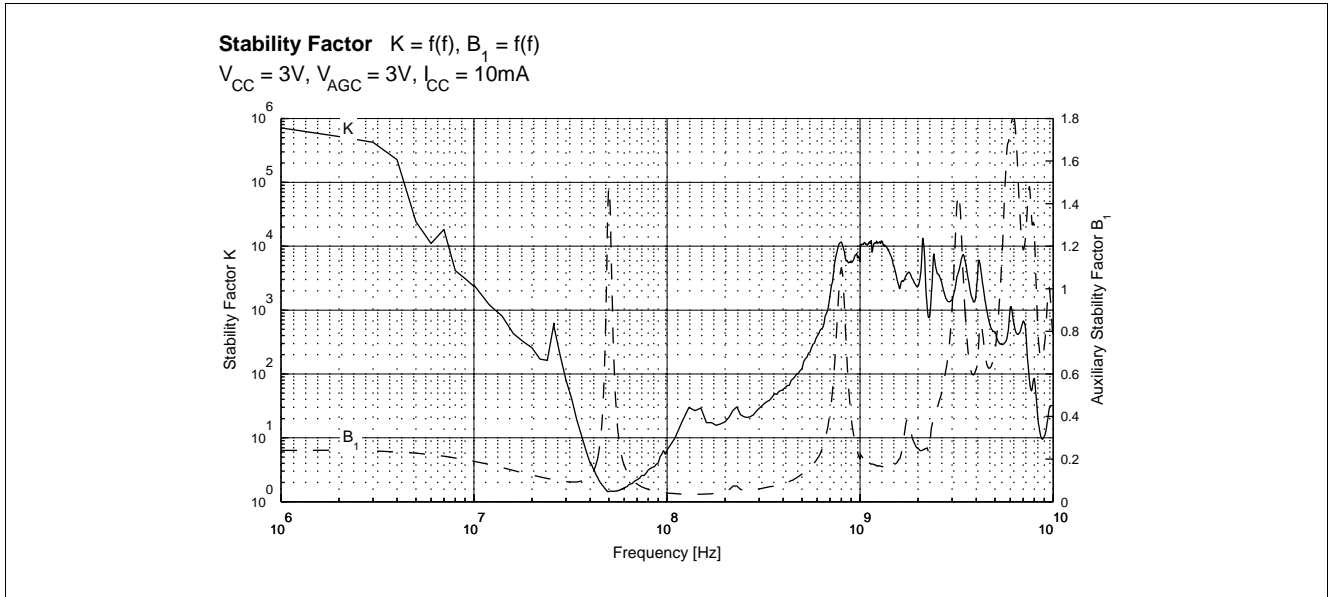

Figure 5 Stability Factor of 50 MHz Configuration

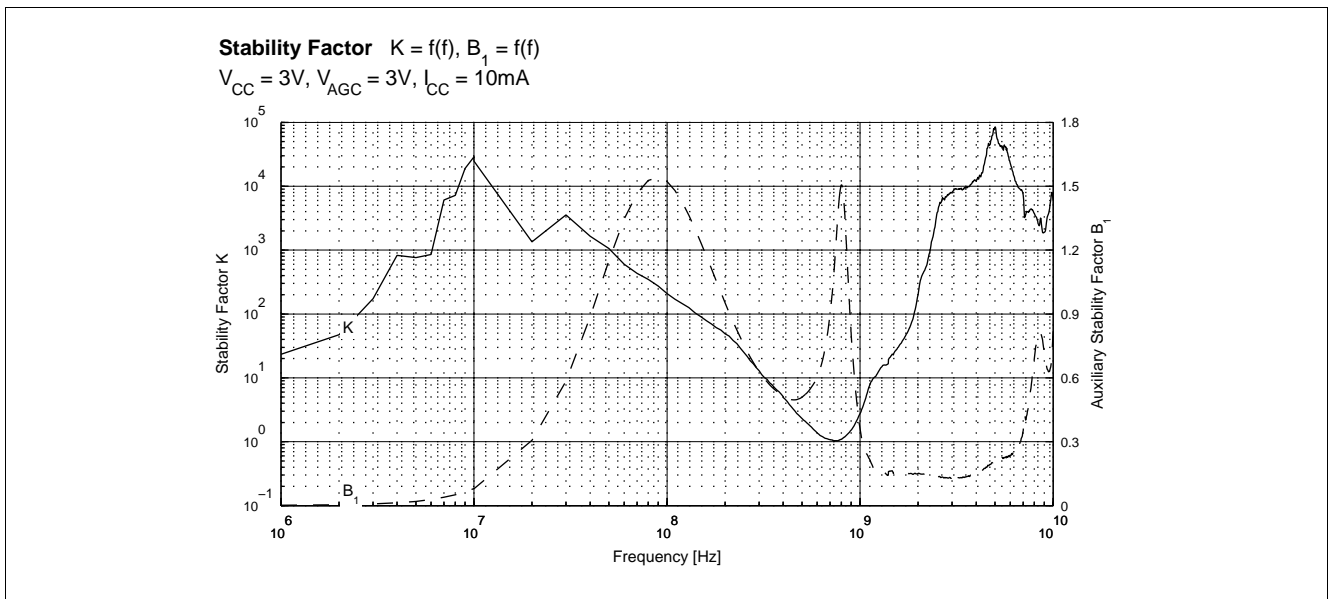

Figure 6 Stability Factor of 800 MHz Configuration

### 3.2 Assembly for 5 V Supply Voltage

The following measurement results show the performance of Infineon's MOSFET BF5030W operating at a supply voltage 5 V. Please note that the bill of materials for a 3 V supply voltage and 5 V supply voltage differs slightly. The noise parameters of the BF5030W at 5 V are roughly the same as the ones at 3 V that are listed in [Table 2](#), and they are therefore not expressed again here.

In the same way as in the previous section some key parameter are listed in [Table 5](#) and [Table 6](#), and are shown again in the form graphs on [Page 15](#) and [Page 16](#). Also a plot of stability factor K is shown once again in [Figure 7](#) and [Figure 8](#), respectively, and one can see that both configuration are again unconditionally stable over a frequency range between 1 MHz and 10 GHz. As already mentioned in the previous section, oscillation will not occur for the 800 MHz configuration if both ports are terminated properly, even if unconditional stability is marginal.

*Note: This Board is designed for minimum noise figure and stable operation rather than maximum power gain.*

**Table 5 Electrical Characteristics of 50 MHz Configuration**

| Parameter   | Symbol         | Value | Unit |
|---|----------------|-------|------|
| <b>DC Characteristics</b>   |                |       |      |
| Supply voltage  | $V_{CC}$       | 5     | V    |
| Automatic gain control voltage  | $V_{AGC}$      | 4     | V    |
| Supply current  | $I_{CC}$       | 10    | mA   |
| <b>AC Characteristics (verified by five samples)</b>                    |                |       |      |
| Power gain<br>$f = 50$ MHz  | $ S_{21} ^2$   | 33    | dB   |
| Input return loss<br>$f = 50$ MHz                                       | $RL_{in}$      | 2.6   | dB   |
| Output return loss<br>$f = 50$ MHz                                      | $RL_{out}$     | 18    | dB   |
| Reverse isolation<br>$f = 50$ MHz                                       | $1/ S_{12} ^2$ | 50    | dB   |
| Noise figure <sup>1)</sup><br>$f = 50$ MHz                              | $NF$           | 1.2   | dB   |
| 1 dB input compression point<br>$f = 50$ MHz                            | $IP_{1dB}$     | -29   | dBm  |
| Input third order intercept point<br>$f_1 = 49.5$ MHz, $f_2 = 50.5$ MHz | $IIP_3$        | -19   | dBm  |

1) Including SMA-connector and PCB losses of approximately 0.5 dB.

*Note: This Board is designed for minimum noise figure and stable operation rather than maximum power gain.*

**Table 6 Electrical Characteristics of 800 MHz Configuration**

| Parameter  | Symbol       | Value | Unit |
|--|--------------|-------|------|
| <b>DC Characteristics</b>                            |              |       |      |
| Supply voltage                                       | $V_{CC}$     | 5     | V    |
| Automatic gain control voltage                       | $V_{AGC}$    | 4     | V    |
| Supply current                                       | $I_{CC}$     | 10    | mA   |
| <b>AC Characteristics (verified by five samples)</b> |              |       |      |
| Power gain<br>$f = 800$ MHz                          | $ S_{21} ^2$ | 22    | dB   |

## Measurement Results Evaluation Report and Application Guide for Low-

**Table 6 Electrical Characteristics of 800 MHz Configuration (cont'd)**

| Parameter   | Symbol         | Value | Unit |
|---|----------------|-------|------|
| Input return loss<br>$f = 800 \text{ MHz}$  | $RL_{in}$      | 2.5   | dB   |
| Output return loss<br>$f = 800 \text{ MHz}$   | $RL_{out}$     | 22    | dB   |
| Reverse isolation<br>$f = 800 \text{ MHz}$  | $1/ S_{12} ^2$ | 35    | dB   |
| Noise figure <sup>1)</sup><br>$f = 800 \text{ MHz}$                                     | $NF$           | 1.7   | dB   |
| 1 dB input compression point<br>$f = 800 \text{ MHz}$                                   | $IP_{1dB}$     | -17   | dBm  |
| Input third order intercept point<br>$f_1 = 799.5 \text{ MHz}, f_2 = 800.5 \text{ MHz}$ | $IIP_3$        | -7    | dBm  |

1) Including SMA-connector and PCB losses of approximately 0.5 dB.

S-Parameters and Noise Figure of 50 MHz Configuration

**Matching**  $|S_{11}|, |S_{22}| = f(f)$   
 $V_{CC} = 5V, V_{AGC} = 4V, I_{CC} = 10mA$

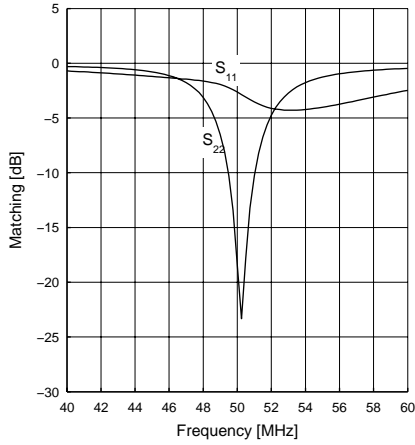

**Power Gain**  $|S_{21}|^2 = f(f)$   
 $V_{CC} = 5V, V_{AGC} = 4V, I_{CC} = 10mA$

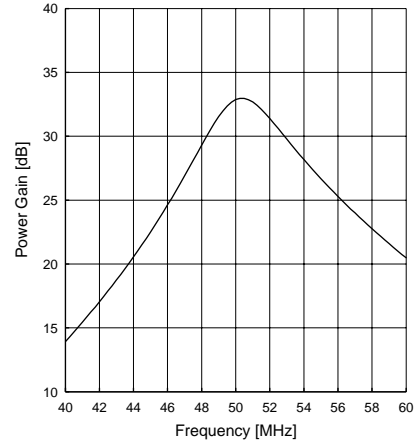

**Reverse Isolation**  $1/|S_{12}|^2 = f(f)$   
 $V_{CC} = 5V, V_{AGC} = 4V, I_{CC} = 10mA$

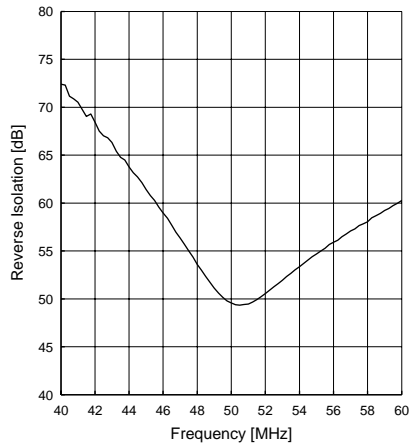

**Noise Figure**  $NF = f(f)$   
 $V_{CC} = 5V, V_{AGC} = 4V, I_{CC} = 10mA$

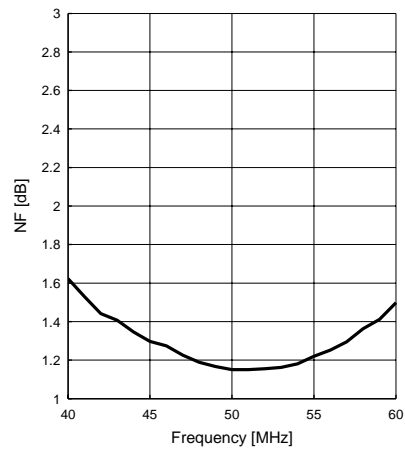

S-Parameters and Noise Figure of 800 MHz Configuration

**Matching**  $|S_{11}|, |S_{22}| = f(f)$   
 $V_{CC} = 5V, V_{AGC} = 4V, I_{CC} = 10mA$

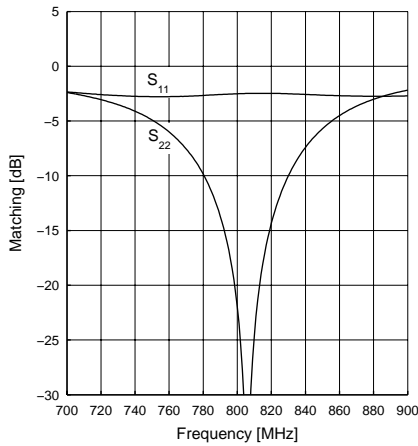

**Power Gain**  $|S_{21}|^2 = f(f)$   
 $V_{CC} = 5V, V_{AGC} = 4V, I_{CC} = 10mA$

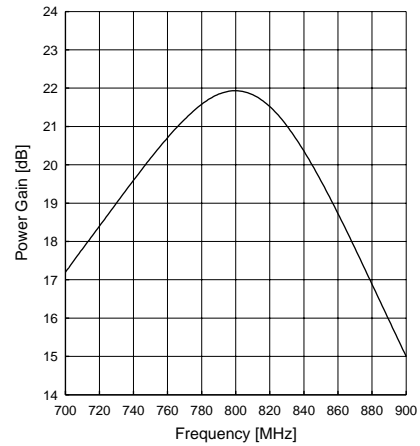

**Reverse Isolation**  $1/|S_{12}|^2 = f(f)$   
 $V_{CC} = 5V, V_{AGC} = 4V, I_{CC} = 10mA$

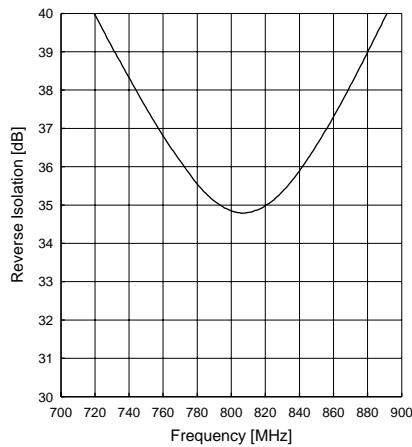

**Noise Figure**  $NF = f(f)$   
 $V_{CC} = 5V, V_{AGC} = 4V, I_{CC} = 10mA$

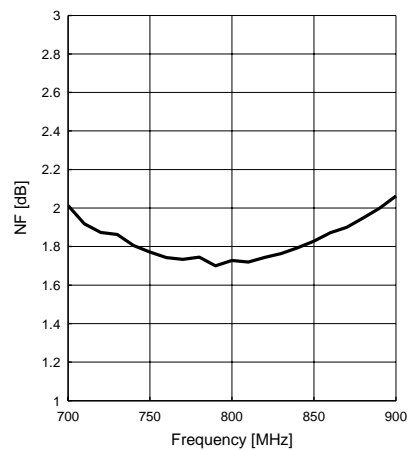



Measurement Results Evaluation Report and Application Guide for Low-

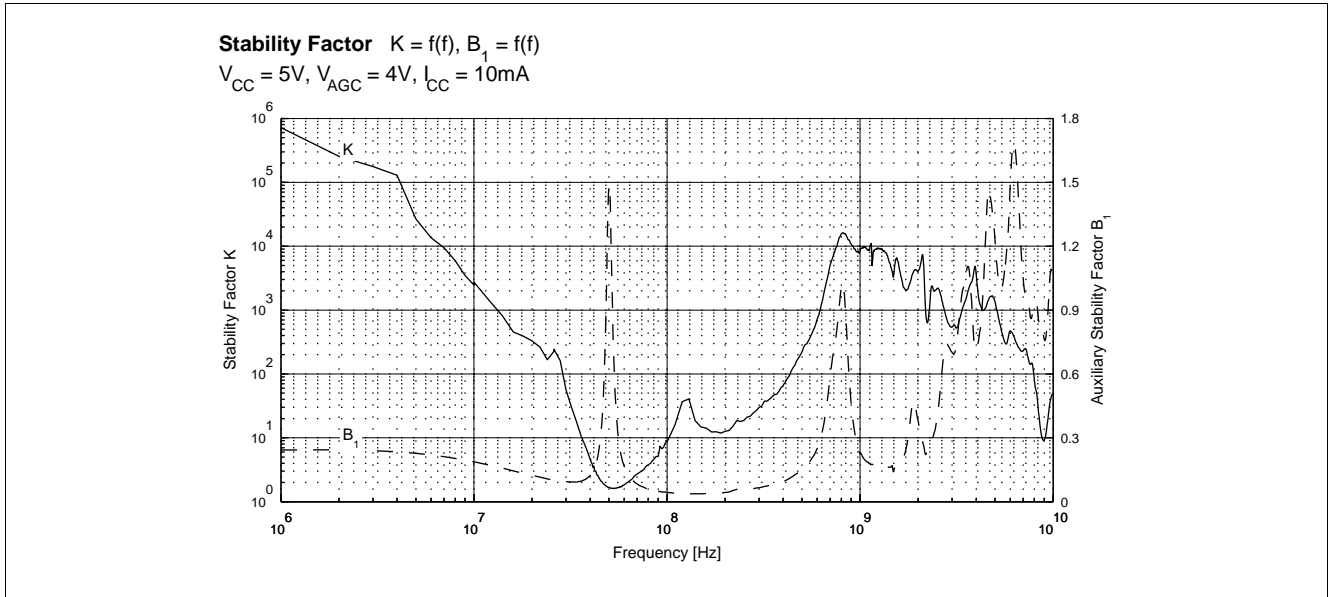

Figure 7 Stability Factor of 50 MHz Configuration

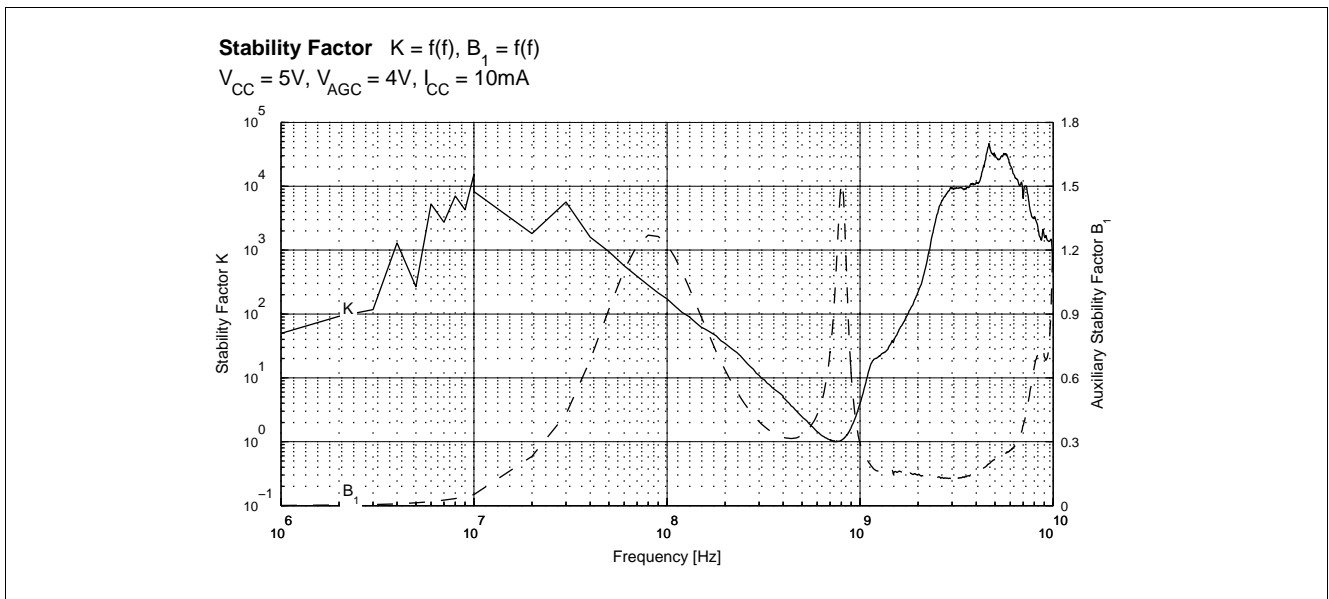

Figure 8 Stability Factor of 800 MHz Configuration