

# DIGITAL CONTROL IC ENABLES EFFICIENT POWER-FACTOR CORRECTION IN AIR-CONDITIONING SYSTEMS

By Aengus Murray,  
International Rectifier

**P**ower inverters that match an air-conditioner's cooling capacity to the load conditions can improve average system efficiency by as much as 40%. But to meet ac-line-emission harmonic standards, manufacturers must add power-factor-correction (PFC) circuits to the input rectifier, adding cost and reducing system efficiency. While input inductance can extend the conduction angle of the input rectifiers to allow the system to meet emission standards in low-power systems, active power-factor-correction circuits that shape the input-current waveform to follow a sinusoidal reference are necessary above the 1-kW level.

The power-factor converter uses a boost topology where the power switches alternately connect the input inductor directly across the input supply or between the input supply and the output-filter capacitor. This topology supports continuous input-current conduction, so controlling the switching duty cycle allows the input current to follow a sinusoidal reference. This configuration automatically limits inrush current at power-up and can maintain a constant dc bus voltage. Since the converter is on the dc side of the bridge rectifier, the controlled current must follow a half-wave rectified sine waveform to force sinusoidal current from the ac line. The problem is that the current-loop bandwidth needs to be in the range of 5 to 10 kHz to track the many higher order harmonics that are present in the half-wave-rectified sine wave. This high-current bandwidth requires a PWM-modulation frequency in the range of 50 to 100 kHz, which results in high power-switch losses and low efficiency. Furthermore, the bandwidth requirement limits the possibilities to save cost by using an all-digital motor controller.

Figure 1 shows a digital power-factor controller that provides an innovative solu-

tion to the current-loop bandwidth problem. The basic PFC control structure consists of an inner current loop that forces the converter's input current to follow the sinusoidal reference, together with an outer voltage loop that determines the current to regulate the dc bus voltage. To meet the bandwidth targets, a direct digital implementation of an analogue PFC system would place severe demands on the A/D-conversion and computation circuits. However, introducing voltage feed-forward into the current loop lowers the bandwidth requirement by a factor of more than three, making a digital implementation possible.

The PFC converter's gain must track the varying input voltage to maintain a constant output voltage. Because the boost converter's gain is an inverse function of the duty cycle, the duty cycle varies as a linear function of the input voltage:

$$\frac{V_{OUT}}{V_{IN}} = \frac{1}{1-D}$$

$$\therefore D = 1 - \frac{V_{OUT}}{V_{IN}}$$

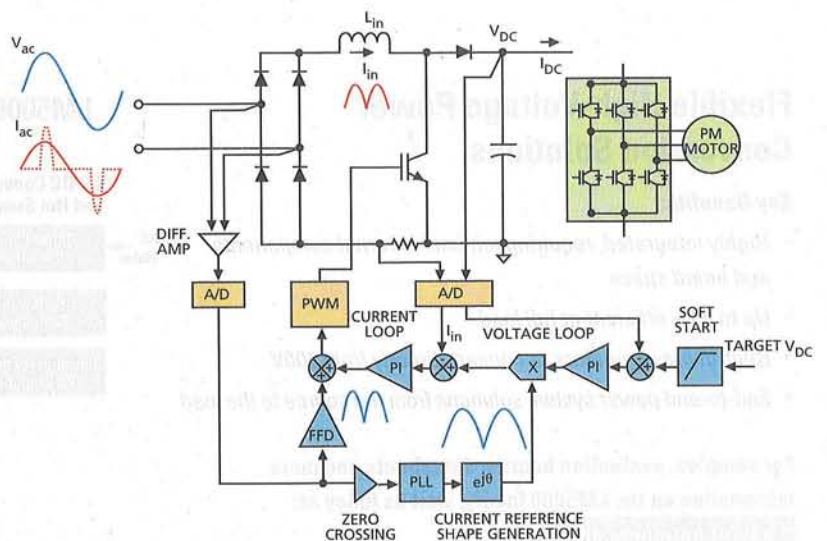

Figure 1: Digitally controlled multi-phase interleaved synchronous buck.

A SPECIAL SUPPLEMENT TO EDN EUROPE

In the improved algorithm, the feed-forward control function scales the input line voltage to calculate the open-loop duty cycle while the current loop adjusts for load variations. The outer voltage loop calculates the required current magnitude based on the voltage error. Multiplying this signal by the half-wave-rectified sine wave calculates the reference signal for the current loop. In this implementation, the phase-locked loop and vector-rotation function calculates a synthesised sine wave to eliminate harmonics in the sampled line voltage. Another feature is the soft-start controller that slowly increases the target dc bus voltage after power-up, eliminating the need for an inrush-current-limiting thermistor.

Digital control ICs for air-conditioning control system can implement the PFC algorithm using elements from International Rectifier's embedded-motion-control-engine (MCE) library and ICs from the company's iMotion portfolio—for example the IRMCF311/2. Such ICs integrate analogue functions including an ADC and buffer amplifiers that sample line voltage, bus voltage, and the converter currents. The MCE library contains a set of control elements such as proportional-plus-integral compensation, vector rotations, and standard mathematical functions. The Matlab/Simulink software package provides the graphical interface to develop the control-algorithm schematics. The PFC control schematic in Figure 2 contains various control elements dragged & dropped from the MCE library.

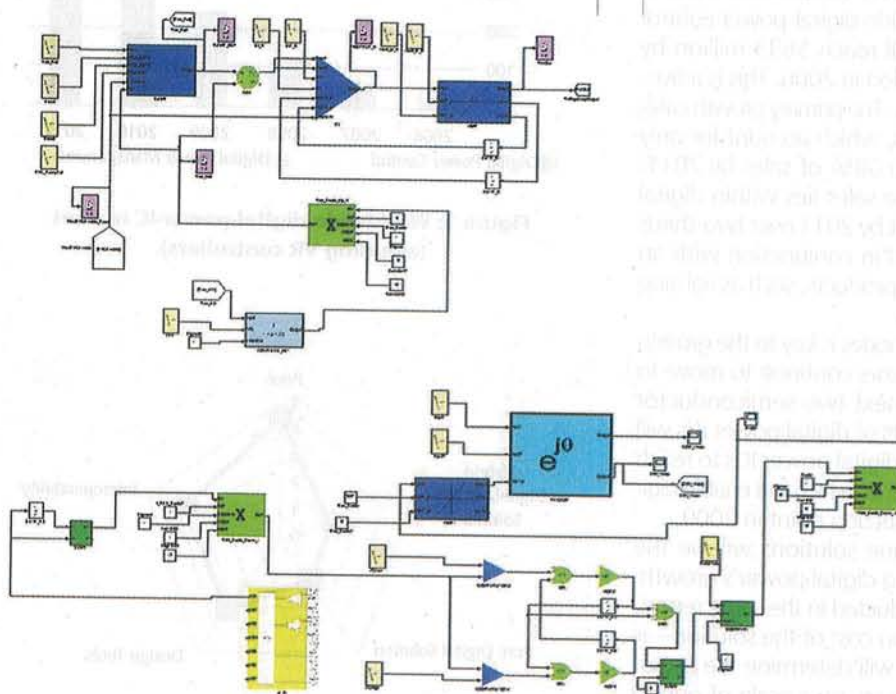

Figure 2: Digital power-factor-algorithm schematic.

Colour-coding distinguishes elements, depending on classification and usage limitations. For example, the yellow blocks are functions such as the ADC inputs and PWM outputs that correspond to specific hardware on the IC. The blue blocks are control functions without specific limitations, but each use consumes a specific number of MCE clock cycles.

A graphical compiler tool then translates the control algorithm netlist into MCE sequencer code that effectively interconnects the corresponding MCE control blocks on the physical IC. PC-based tools load the sequencer code into MCE sequencer code RAM. This unique design platform allows very efficient implementation of digital power control without any software coding.

The PFC function is just one subsystem in an air-conditioning control system. In the example, the digital control IC also controls the air-conditioner's compressor and fan motor using elements from the MCE control library. The execution of the control algorithms using a hardware engine enables simultaneous control of the two ac motors and the PFC controller, simplifying system design. The availability of graphics that translate the control schematic directly into MCE sequencer code significantly simplifies the controller-design process and eases adoption. Furthermore, integrating an independent 8-bit microcontroller facilitates the addition of air-conditioning application functions.

The digital PFC algorithm can meet the target harmonic specifications for a 4-kW input system with a 30-kHz switching frequency in the input converter. This approach reduces IGBT switching losses by a factor of more than three, and so improves efficiency. The compressor control algorithm includes a field-oriented control algorithm that optimises the compressor motor's operation, yielding further efficiency gains. Benchmark testing of the example system shows a compressor output efficiency of 95%, which is almost 2% better than a competitive analogue solution. Such control ICs enable further improvements in air-conditioning-system efficiency, as energy-conservation agencies worldwide continually demand. ■