

EiceDRIVER™

2ED020I12-FI

2 channel high and low side IGBT driver for inverter applications



Never stop thinking

Integrated Driver IC: Embedded microplanar transformer within an integrated circuit

The trademark EiceDRIVER™ describes a new IGBT driver family based on a new IGBT driver IC technology

- **Coreless transformer technology offers the advantage combination of existing IGBT/MOSFET driver technologies like high isolation capability, easy integration of logic functions and a high cost effectiveness by avoiding the disadvantages like aging, EMI sensitiveness and reduced reliability**
- **Available Package for 2ED020I12-FI:
PG-DSO18 – RoHS compliant**
- **Long lifetime at high switching frequencies and high temperatures**



Best in class with EiceDRIVER™

EiceDRIVER™ Family Applications - General



Applications

- **Low and medium power industrial drives**
- **UPS systems and other power supplies**
- **Medical technologies**
- **Welding equipment**
- **Solar inverter**

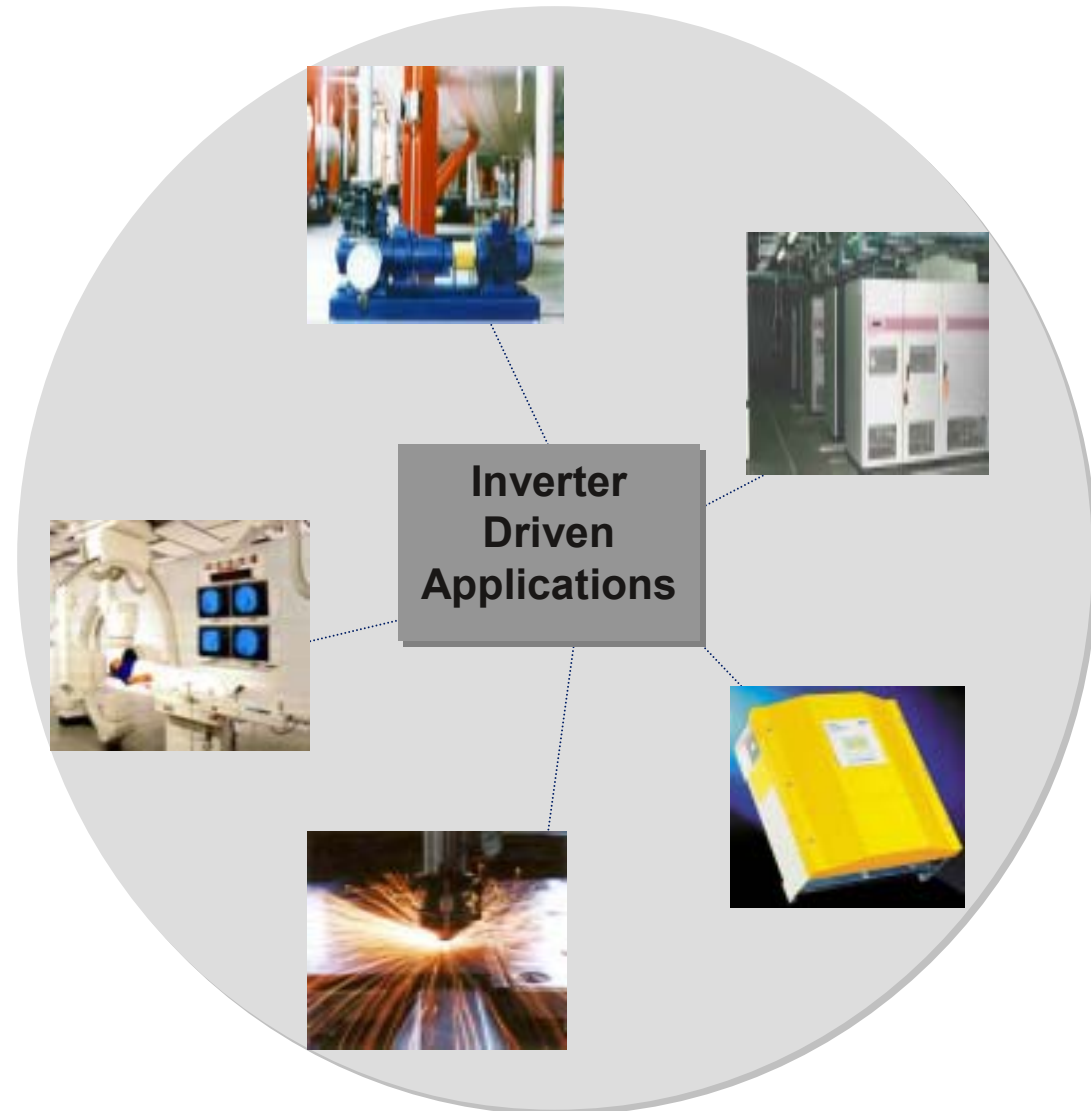

Why Coreless Transformer Technology?

Challenge:

Signal transmission (unidirectional) between two electrical regions of equal or different potential with reinforced or functional insulation

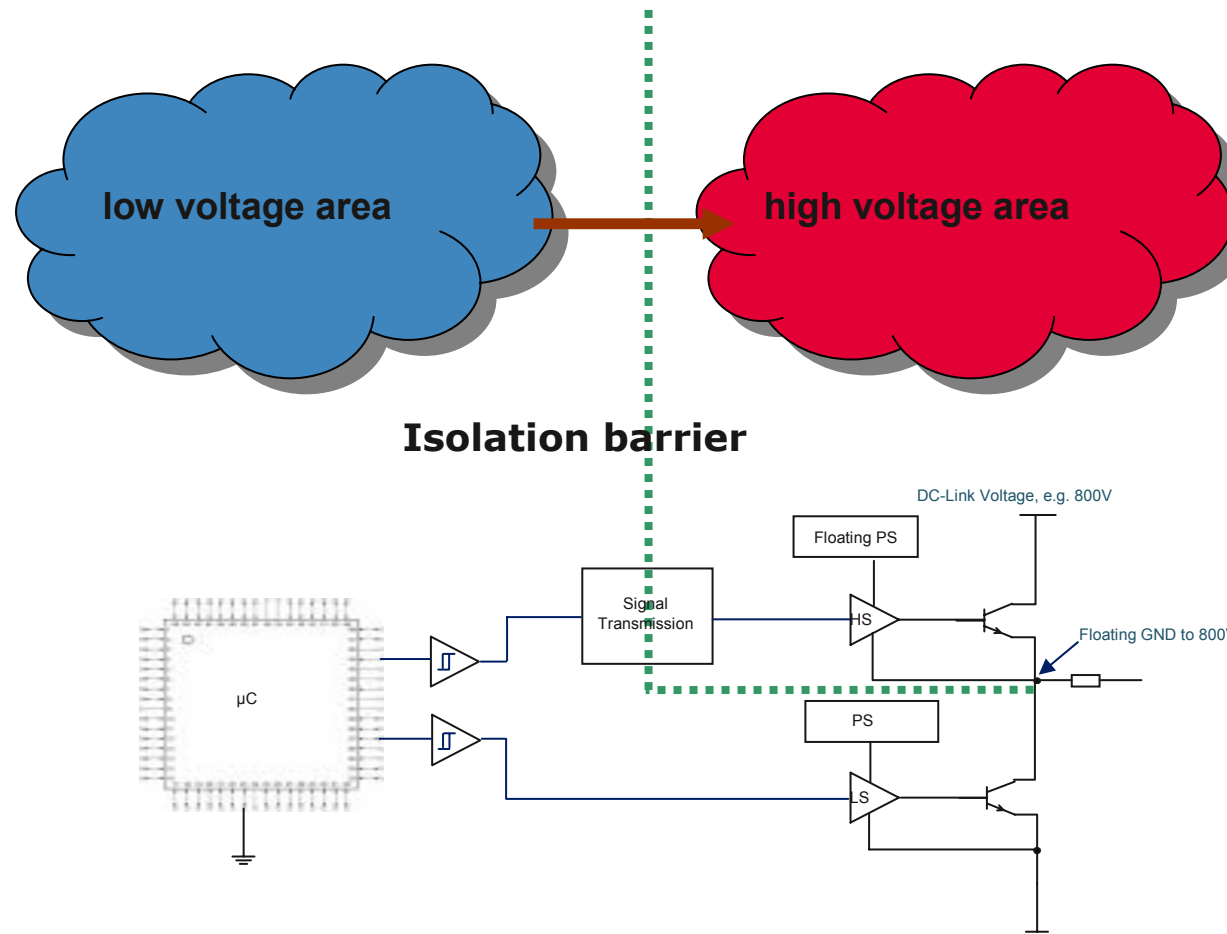

New Technology for High Voltage Driver Requirements

Coreless Transformer Technology

Existing Solutions:

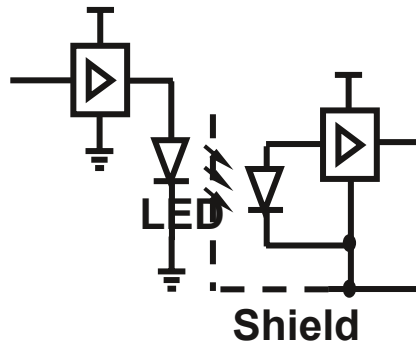

Optocoupler

Expensive
Reduced reliability
(aging)

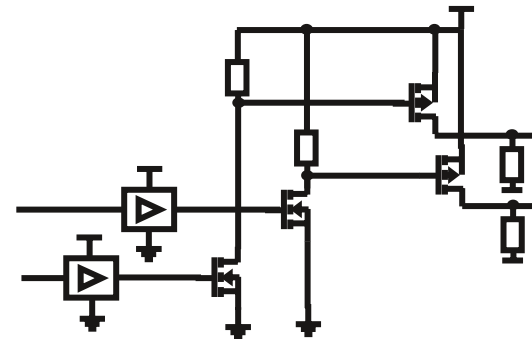

Level Shifter

Requires additional
components to
achieve needed
isolation level

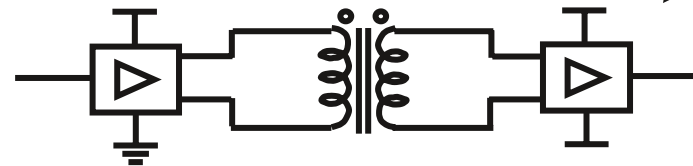

New Solution for Driver IC's: Discrete magnetic transformer

The coreless transformer principle offers many advantages

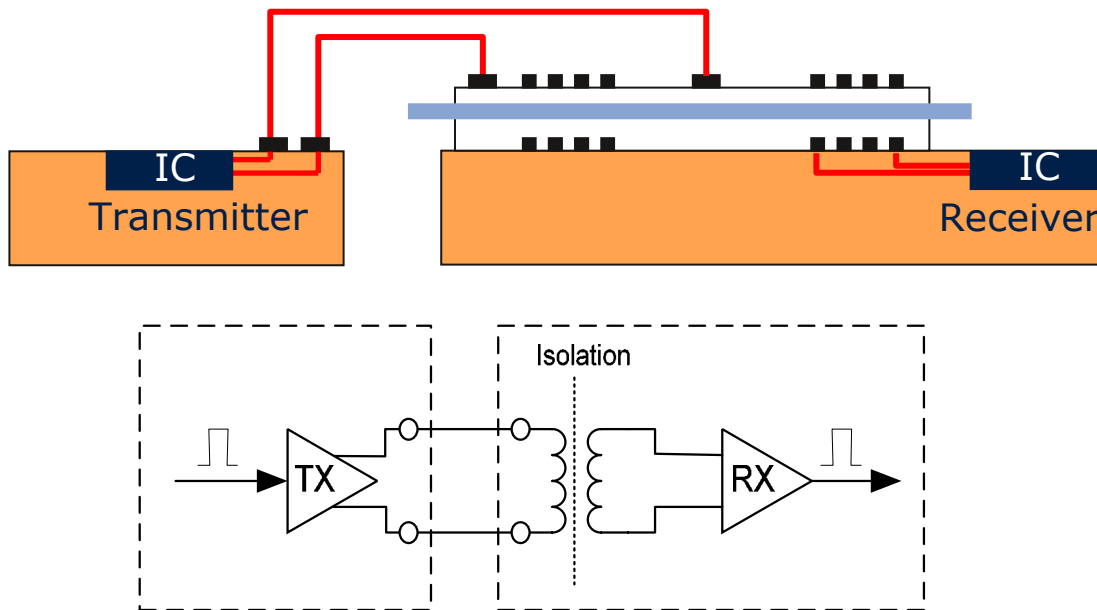

Technology Advantages

- no degradation over time
- gain reliability
- isolation strength
- high temperature range
- very fast transmission capability
- low power consumption
- long lifetime

EiceDRIVER™ Functional Isolation



Typical Inverter Applications @ Pout 1KW – 10KW

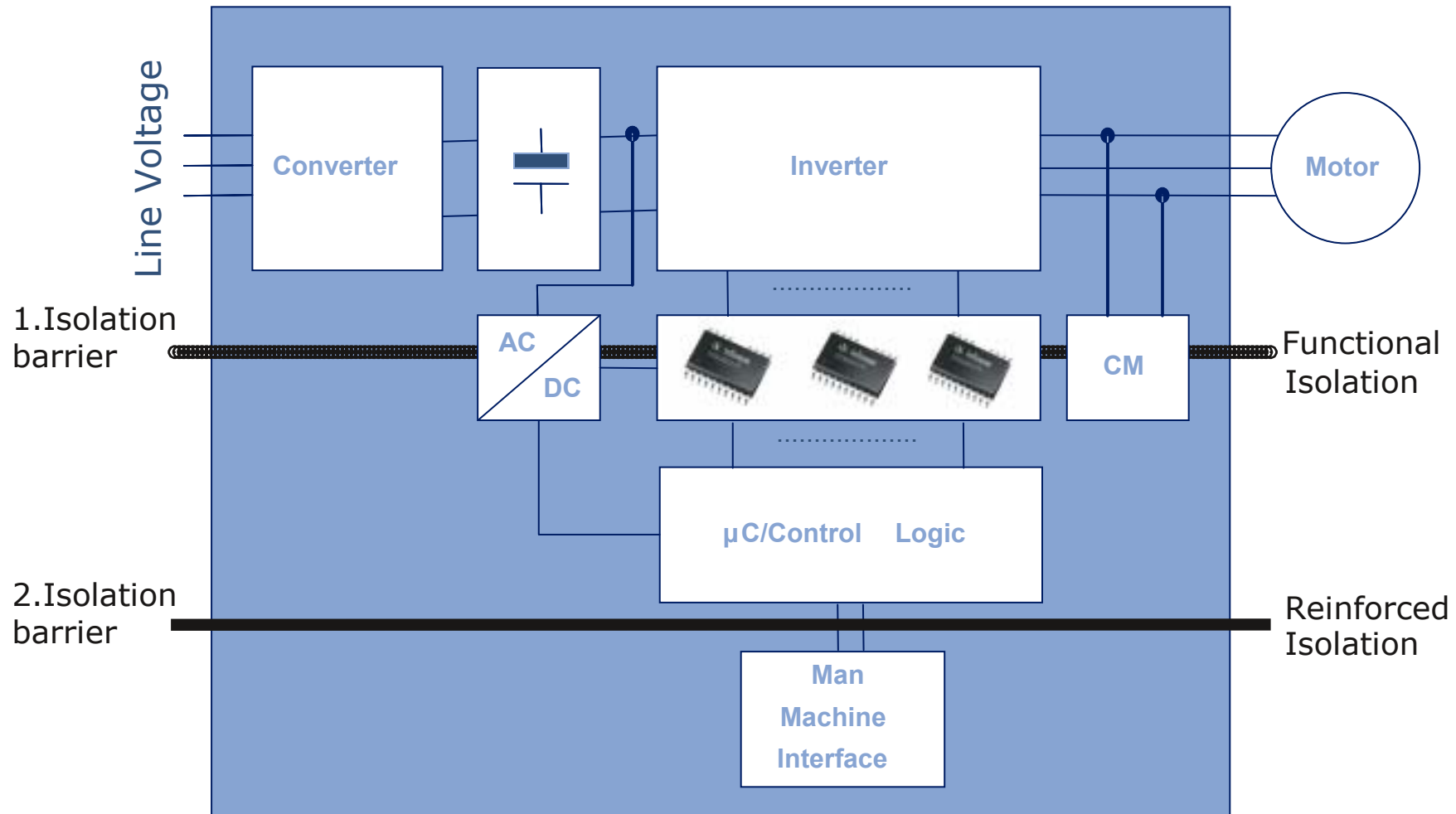

2ED020I12-FI provides functional isolation

EiceDRIVER™ 2ED020I12-FI Schematic



- Main Features:**
- Halfbridge IGBT/MOSFET driver
 - Fully operational up to 1200V_{DC}
 - 1A/-2A peak gate current
 - typ. 85ns propagation delay / ±25ns propagation delay mismatch
 - Burst approved according IEC61000-4-4 level4 in a reference inverter

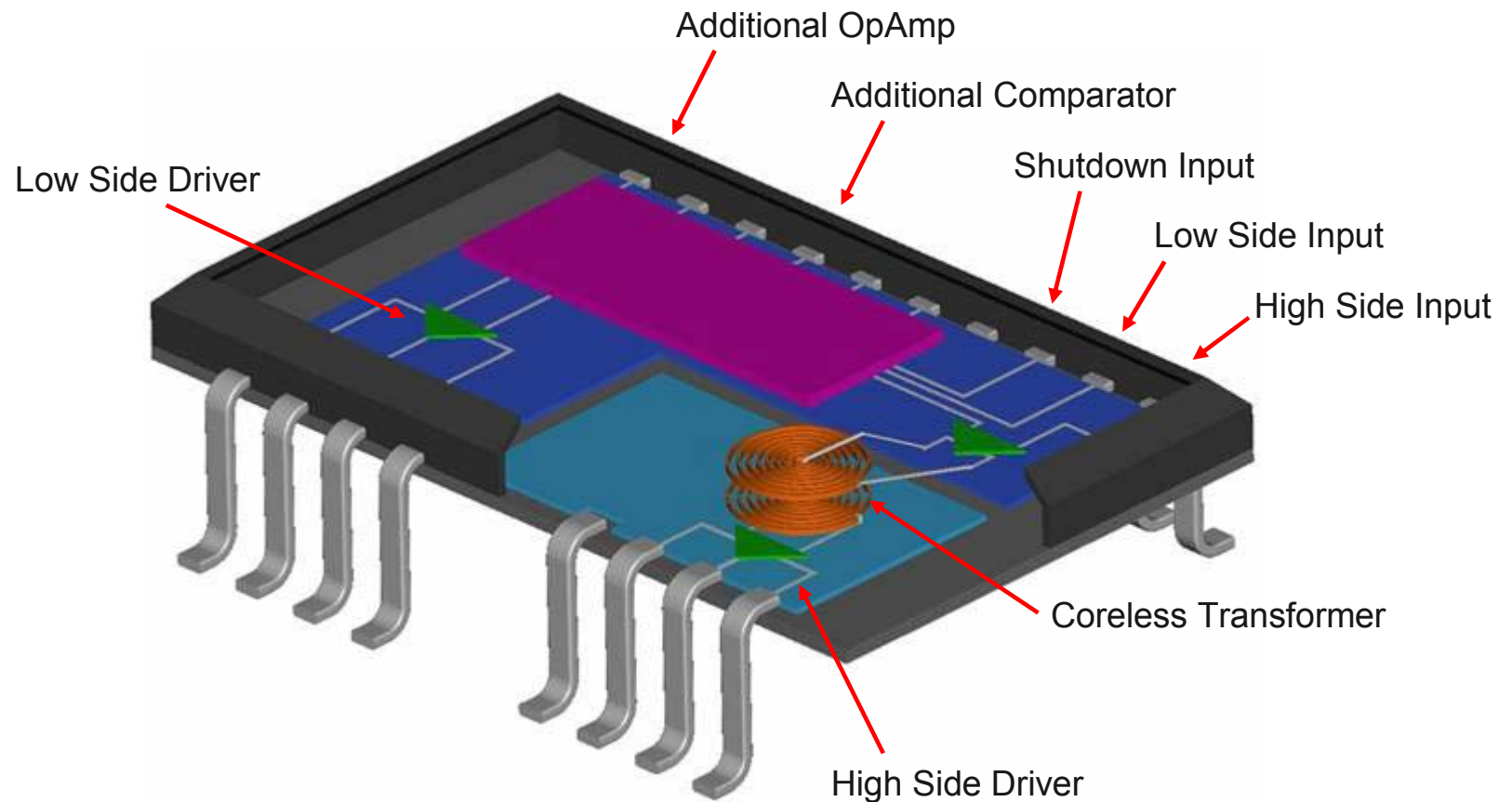

2ED020I12-FI fits inverter applications perfectly

EiceDRIVER™ Block Diagram 2ED020I12-FI

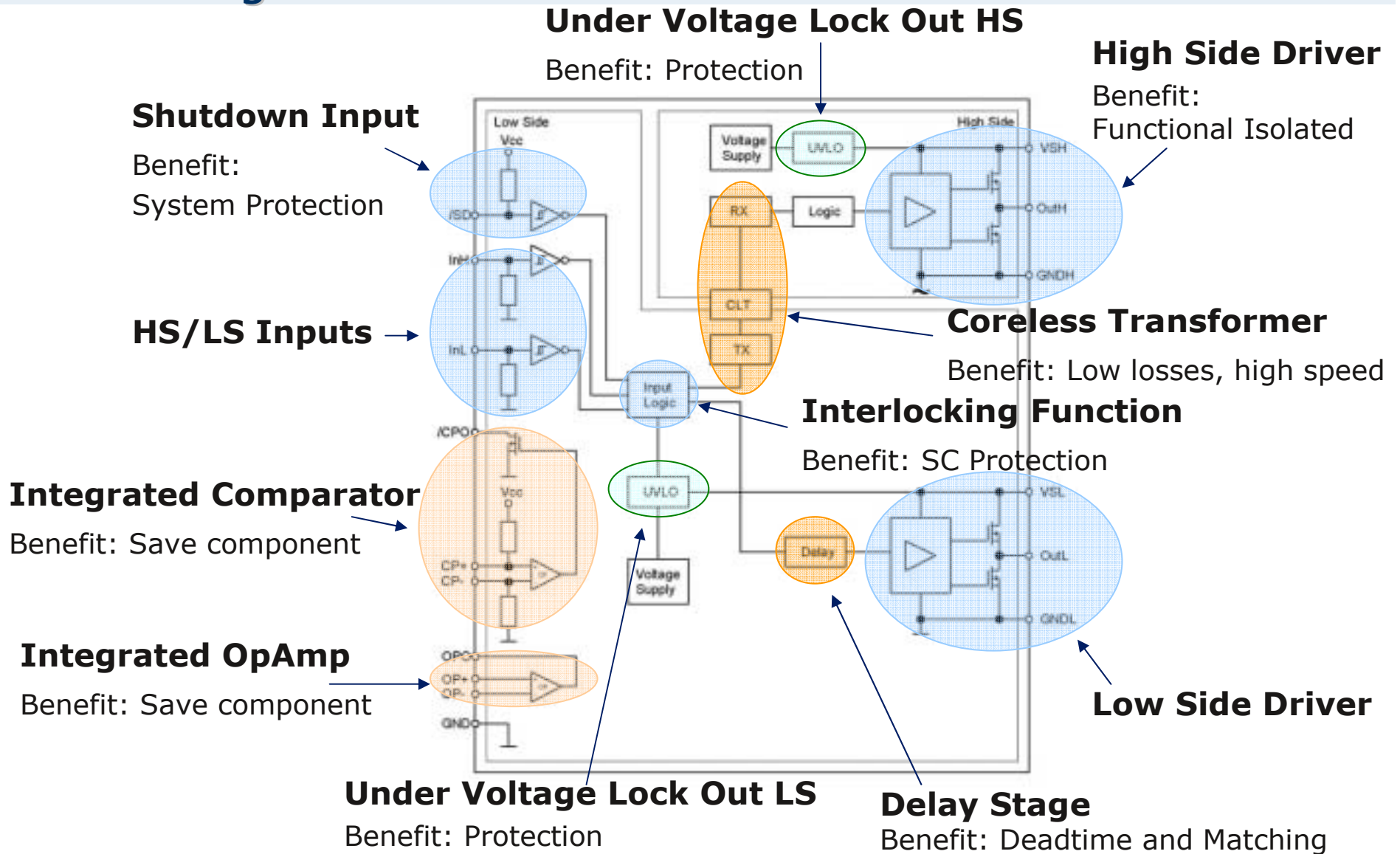

The Driver IC with customer benefits

Features and Benefits of EiceDRIVER™

2ED020I12-FI

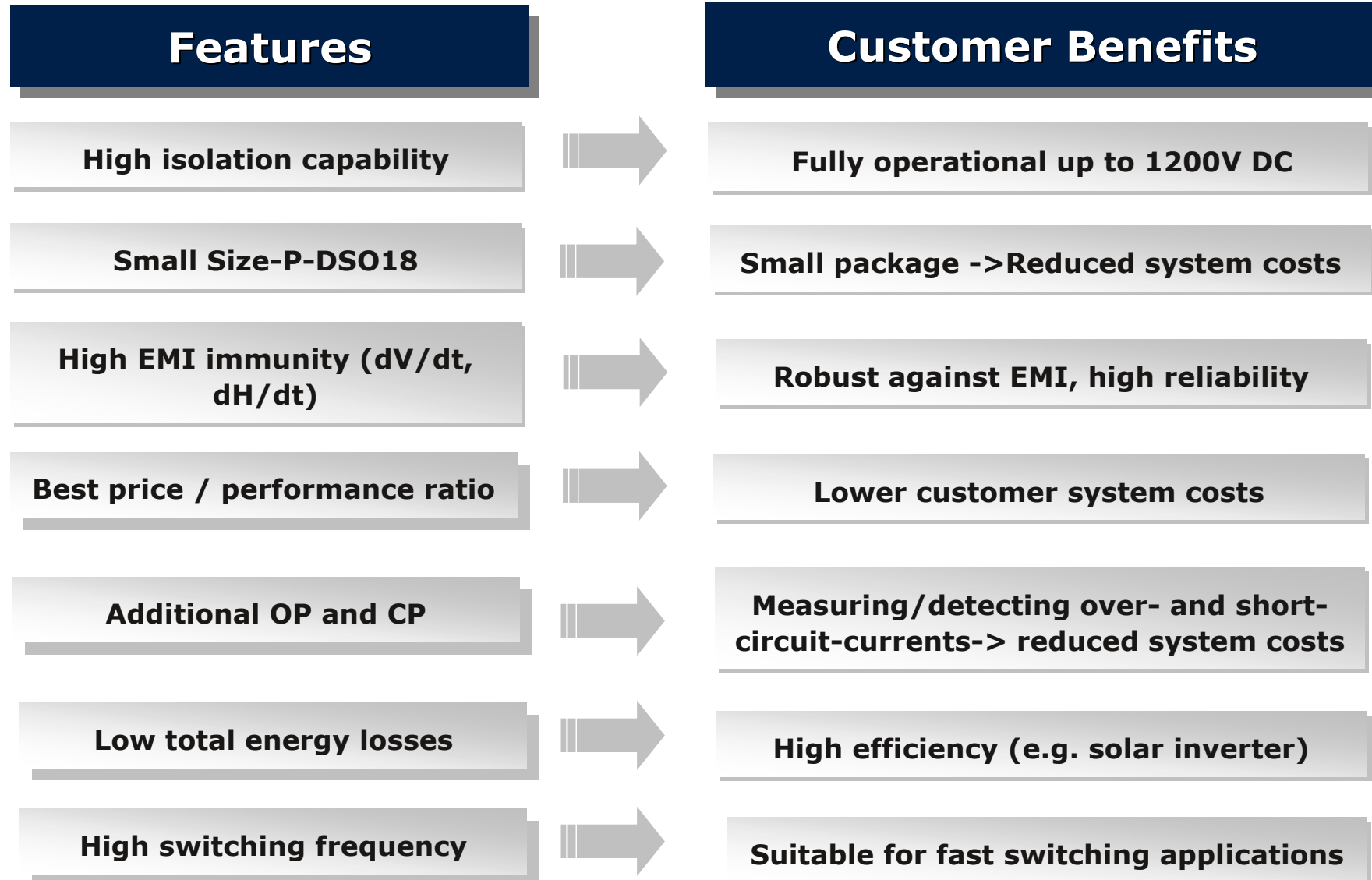

Competition Environment

- Basically a lot of driver combinations to secure customers isolation, space and function requirements are possible.
- Mainly system costs and board space leads to a decision to use a component.
- Main Competitors 2ED020I12-FI: IR, STM, Toshiba

Type / Para.	Ch.	Technology	Operation Voltage	Output Current	Prop. Delay typ	Delay Mismatch	OP / CP integrated	Package	Isolation Voltage	max. Frequency	Common Mode Transient Immunity (HS)
2ED020I12-FI	2	CLT	1200V DC	1A/-2A	85 ns	25 ns	yes	PG-DSO18	2,5 KVrms	200 KHz	+50KV/μs
IR 2213	2	LevelShift	1200V DC	1,7A/-2A	280 ns	30 ns	no	PDIP14/ SOIC 16	2,5 KVrms	30 KHz	n.d.
TD 350 (STM)	2	LevelShift	1200V DC	0,75A/-1,25A	270 (min) - 800 (max)	60 ns	no	DSO 14	2,5 KVrms	30 KHz	n.d.
HCPL-315J	2	Optocoupler	1200V DC	0,5A/-0,6A	500 ns	350 ns	no	DSO 16		25 KHz	+15KV/μs
TLP 250 (Toshiba)	1	Optocoupler	1200V DC	1,5A/-1,5A	150 ns	-	no	DIP 8	2,5 KVrms	25 KHz	+5KV/μs

EiceDRIVER™ Nomenclature



EiceDRIVER™ 2 ED 020 I 12 - F I

Green / Robust Version

I = with interlocking function
C = without interlocking function

Isolation Class

F = Function Isolation
S = Safety Isolation
ST = Safety Isolation/Traktion Application

Voltage Class

06 = 600V
12 = 1200V
17 = 1700V

Type

C = Board
I = IC (Coreless Transformer Technology)
L = IC (Level Shifter)

Peak Output Current for Driver

003 = 300mA
020 = 2A

Function

ED = IGBT/MOSFET Driver

Driver Channels

1 = Driver for one IGBT
2 = Driver for Half-Bridge
6 = Driver for Six-Pack

Infineon – Never stop thinking