

**Final datasheet**

**CoolSiC™ 1400 V SiC MOSFET G2 : Silicon Carbide MOSFET with .XT interconnection technology**

**特性**

- $V_{DSS} = 1400\text{ V}$  at  $T_{vj} = 25^\circ\text{C}$
- $I_{DDC} = 37\text{ A}$  at  $T_C = 100^\circ\text{C}$
- $R_{DS(on)} = 38\text{ m}\Omega$  at  $V_{GS} = 18\text{ V}$ ,  $T_{vj} = 25^\circ\text{C}$
- Very low switching losses
- Short circuit withstand time  $2\ \mu\text{s}$
- Benchmark gate threshold voltage,  $V_{GS(th)} = 4.2\text{ V}$
- Robust against parasitic turn on, 0 V turn-off gate voltage can be applied
- Robust body diode for hard commutation
- .XT interconnection technology for best-in-class thermal performance
- 可以从下面链接寻找适合的英飞凌驱动 IC <https://www.infineon.com/gdfinder>



- Halogen-free
- Green
- Lead-free
- RoHS

**可选应用**

- General purpose drives (GPD)
- EV Charging
- Online UPS / Industrial UPS
- String inverter
- Energy storage systems (ESS)
- Welding

**产品认证**

- Qualified for industrial applications according to the relevant tests of JEDEC47/20/22

**描述**

Pin definition:

- Pin 1 - Drain
- Pin 2 - Source
- Pin 3 - Kelvin sense contact
- Pin 4 - Gate

Note: the source and sense pins are not exchangeable, their exchange might lead to malfunction

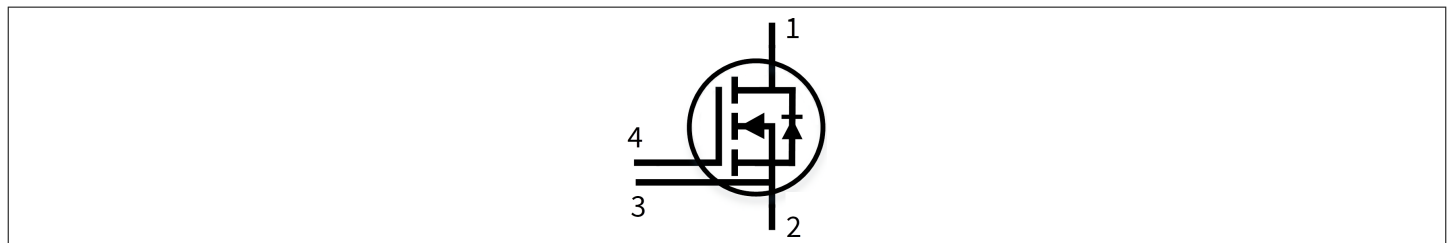

Type	Package	Marking
IMZC140R038M2H	PG-TO247-4-U07	14M2H038

## 内容

	描述.....	1
	特性.....	1
	可选应用.....	1
	产品认证.....	1
	内容.....	2
<b>1</b>	<b>封装.....</b>	<b>3</b>
<b>2</b>	<b>MOSFET.....</b>	<b>3</b>
<b>3</b>	<b>Body diode (MOSFET).....</b>	<b>6</b>
<b>4</b>	<b>特征参数图表.....</b>	<b>8</b>
<b>5</b>	<b>封装尺寸.....</b>	<b>15</b>
<b>6</b>	<b>Testing conditions.....</b>	<b>16</b>
	修订历史.....	17
	免责声明.....	18

1 封装

## 1 封装

表 1 特征值

特征参数	代号	标注或测试条件	数值			单位
			最小值	典型值	最大值	
Storage temperature	$T_{stg}$		-55		150	°C
Soldering temperature	$T_{sold}$	Wave soldering only allowed at leads 1.6 mm (0.063 in.) from case for 10 s			260	°C
Mounting torque	$M$	M3 screw, Maximum of mounting processes: 3			0.6	Nm
Thermal resistance, junction-ambient	$R_{th(j-a)}$				62	K/W
MOSFET/body diode thermal resistance, junction-case	$R_{th(j-c)}$			0.47	0.62	K/W

## 2 MOSFET

表 2 最大标定值

特征参数	代号	标注或测试条件	数值	单位	
漏源极电压	$V_{DSS}$	$T_{vj} \geq 25\text{ °C}$	1400	V	
Continuous DC drain current for $R_{th(j-c,max)}$ , limited by $T_{vj(max)}$	$I_{DDC}$	$V_{GS} = 18\text{ V}$	$T_c = 25\text{ °C}$	52	A
			$T_c = 100\text{ °C}$	37	
Peak drain current, $t_p$ limited by $T_{vj(max)}$ <sup>1)</sup>	$I_{DM}$	$V_{GS} = 18\text{ V}$	185	A	
Gate-source voltage, max. transient voltage	$V_{GS}$	$t_p \leq 0.5\ \mu\text{s}$ , $D < 0.01$	-10...25	V	
Gate-source voltage, max. static voltage <sup>2)</sup>	$V_{GS}$		-7...23	V	
Avalanche energy, single pulse	$E_{AS}$	$I_D = 20.4\text{ A}$ , $V_{DD} = 50\text{ V}$ , $L = 1.2\text{ mH}$ , $T_{vj(start)} = 25\text{ °C}$	255	mJ	
Avalanche energy, repetitive	$E_{AR}$	$I_D = 20.4\text{ A}$ , $V_{DD} = 50\text{ V}$ , $L = 6.2\ \mu\text{H}$ , $T_{vj(start)} = 25\text{ °C}$	1.3	mJ	
Short-circuit withstand time	$t_{SC}$	$V_{DD} \leq 800\text{ V}$ , $V_{DS,peak} < 1400\text{ V}$ , $V_{GS(on)} = 15\text{ V}$ , $T_{vj(start)} = 25\text{ °C}$	2	$\mu\text{s}$	
Power dissipation, limited by $T_{vj(max)}$	$P_{tot}$		$T_c = 25\text{ °C}$	242	W
			$T_c = 100\text{ °C}$	121	

1) Verified by design.

2) The maximum gate-source voltage in the application design should be in accordance to IPC-9592B.

**表 3** 推荐值

特征参数	代号	标注或测试条件	[ZH]Values	单位
Recommended turn-on gate voltage	$V_{GS(on)}$		15...18	V
Recommended turn-off gate voltage	$V_{GS(off)}$		-5...0	V

**表 4** 特征值

特征参数	代号	标注或测试条件	数值			单位	
			最小值	典型值	最大值		
Drain-source on-state resistance	$R_{DS(on)}$	$I_D = 20.4 \text{ A}$	$T_{vj} = 25 \text{ }^\circ\text{C}$ , $V_{GS(on)} = 18 \text{ V}$		38		mΩ
			$T_{vj} = 150 \text{ }^\circ\text{C}$ , $V_{GS(on)} = 18 \text{ V}$		81.3	106.5	
			$T_{vj} = 175 \text{ }^\circ\text{C}$ , $V_{GS(on)} = 18 \text{ V}$		94		
			$T_{vj} = 25 \text{ }^\circ\text{C}$ , $V_{GS(on)} = 15 \text{ V}$		47		
Gate-source threshold voltage	$V_{GS(th)}$	$I_D = 6.4 \text{ mA}$ , $V_{DS} = V_{GS}$ (tested after 1 ms pulse at $V_{GS} = 20 \text{ V}$ )	$T_{vj} = 25 \text{ }^\circ\text{C}$	3.5	4.2	5.1	V
			$T_{vj} = 175 \text{ }^\circ\text{C}$		3.2		
Zero gate-voltage drain current	$I_{DSS}$	$V_{DS} = 1400 \text{ V}$ , $V_{GS} = 0 \text{ V}$	$T_{vj} = 25 \text{ }^\circ\text{C}$			150	μA
			$T_{vj} = 175 \text{ }^\circ\text{C}$		2.6		
Gate leakage current	$I_{GSS}$	$V_{DS} = 0 \text{ V}$	$V_{GS} = 23 \text{ V}$			120	nA
			$V_{GS} = -10 \text{ V}$			-120	
Forward transconductance	$g_{fs}$	$I_D = 20.4 \text{ A}$ , $V_{DS} = 20 \text{ V}$			13		S
Internal gate resistance	$R_{G,int}$	$f = 1 \text{ MHz}$ , $V_{AC} = 25 \text{ mV}$			2.75		Ω
Input capacitance	$C_{iss}$	$V_{DS} = 1000 \text{ V}$ , $V_{GS} = 0 \text{ V}$ , $f = 100 \text{ kHz}$ , $V_{AC} = 25 \text{ mV}$			1480		pF
Output capacitance	$C_{oss}$	$V_{DS} = 1000 \text{ V}$ , $V_{GS} = 0 \text{ V}$ , $f = 100 \text{ kHz}$ , $V_{AC} = 25 \text{ mV}$			50		pF
Reverse transfer capacitance	$C_{rss}$	$V_{DS} = 1000 \text{ V}$ , $V_{GS} = 0 \text{ V}$ , $f = 100 \text{ kHz}$ , $V_{AC} = 25 \text{ mV}$			4.5		pF
$C_{oss}$ stored energy	$E_{oss}$	Calculated based on $C_{oss} = f(V_{DD})$			32		μJ
Output charge	$Q_{oss}$	Calculated based on $C_{oss} = f(V_{DD})$			87		nC
Effective output capacitance, energy related	$C_{o(er)}$	$V_{DS} = 0...1000 \text{ V}$ , $V_{GS} = 0 \text{ V}$ , Calculated based on $E_{oss}$			99		pF

(待续)

表 4 (续) 特征值

特征参数	代号	标注或测试条件	数值			单位
			最小值	典型值	最大值	
Effective output capacitance, time related	$C_{o(tr)}$	$I_D = \text{constant}, V_{DS} = 0 \dots 1000 \text{ V}, V_{GS} = 0 \text{ V}$ , Calculated based on $Q_{oss}$		109		pF
Total gate charge	$Q_G$	$V_{DD} = 1000 \text{ V}, I_D = 20.4 \text{ A}, V_{GS} = 0/18 \text{ V}$ , turn-on pulse		41		nC
Plateau gate charge	$Q_{GS(pl)}$	$V_{DD} = 1000 \text{ V}, I_D = 20.4 \text{ A}, V_{GS} = 0/18 \text{ V}$ , turn-on pulse		11.6		nC
Gate-drain charge	$Q_{GD}$	$V_{DD} = 1000 \text{ V}, I_D = 20.4 \text{ A}, V_{GS} = 0/18 \text{ V}$ , turn-on pulse		10.6		nC
Turn-on delay time	$t_{d(on)}$	$V_{DD} = 1000 \text{ V}, I_D = 20.4 \text{ A}, V_{GS} = 0/18 \text{ V}, R_{G,ext} = 2.3 \Omega, L_G = 12 \text{ nH}$ , diode: body diode at $V_{GS} = 0 \text{ V}$	$T_{vj} = 25 \text{ }^\circ\text{C}$	5.3		ns
			$T_{vj} = 175 \text{ }^\circ\text{C}$	4.6		
Rise time	$t_r$	$V_{DD} = 1000 \text{ V}, I_D = 20.4 \text{ A}, V_{GS} = 0/18 \text{ V}, R_{G,ext} = 2.3 \Omega, L_G = 12 \text{ nH}$ , diode: body diode at $V_{GS} = 0 \text{ V}$	$T_{vj} = 25 \text{ }^\circ\text{C}$	3.1		ns
			$T_{vj} = 175 \text{ }^\circ\text{C}$	2.9		
Turn-off delay time	$t_{d(off)}$	$V_{DD} = 1000 \text{ V}, I_D = 20.4 \text{ A}, V_{GS} = 0/18 \text{ V}, R_{G,ext} = 2.3 \Omega, L_G = 12 \text{ nH}$ , diode: body diode at $V_{GS} = 0 \text{ V}$	$T_{vj} = 25 \text{ }^\circ\text{C}$	13		ns
			$T_{vj} = 175 \text{ }^\circ\text{C}$	14		
Fall time	$t_f$	$V_{DD} = 1000 \text{ V}, I_D = 20.4 \text{ A}, V_{GS} = 0/18 \text{ V}, R_{G,ext} = 2.3 \Omega, L_G = 12 \text{ nH}$ , diode: body diode at $V_{GS} = 0 \text{ V}$	$T_{vj} = 25 \text{ }^\circ\text{C}$	5.1		ns
			$T_{vj} = 175 \text{ }^\circ\text{C}$	5.6		
Turn-on energy	$E_{on}$	$V_{DD} = 1000 \text{ V}, I_D = 20.4 \text{ A}, V_{GS} = 0/18 \text{ V}, R_{G,ext} = 2.3 \Omega, L_G = 12 \text{ nH}$ , diode: body diode at $V_{GS} = 0 \text{ V}$	$T_{vj} = 25 \text{ }^\circ\text{C}$	153		$\mu\text{J}$
			$T_{vj} = 175 \text{ }^\circ\text{C}$	504		
Turn-off energy	$E_{off}$	$V_{DD} = 1000 \text{ V}, I_D = 20.4 \text{ A}, V_{GS} = 0/18 \text{ V}, R_{G,ext} = 2.3 \Omega, L_G = 12 \text{ nH}$ , diode: body diode at $V_{GS} = 0 \text{ V}$	$T_{vj} = 25 \text{ }^\circ\text{C}$	50		$\mu\text{J}$
			$T_{vj} = 175 \text{ }^\circ\text{C}$	58		

(待续)

表 4 (续) 特征值

特征参数	代号	标注或测试条件	数值			单位
			最小值	典型值	最大值	
Total switching energy <sup>1)</sup>	$E_{tot}$	$V_{DD} = 1000\text{ V}, I_D = 20.4\text{ A},$ $V_{GS} = 0/18\text{ V},$ $R_{G,ext} = 2.3\ \Omega, L_\sigma = 12\text{ nH},$ diode: body diode at $V_{GS} = 0\text{ V}$	$T_{vj} = 25\text{ }^\circ\text{C}$	268		$\mu\text{J}$
			$T_{vj} = 175\text{ }^\circ\text{C}$	838		
Turn-on energy at -5 V	$E_{on}$	$V_{DD} = 1000\text{ V}, I_D = 20.4\text{ A},$ $V_{GS} = -5/18\text{ V},$ $R_{G,ext} = 2.3\ \Omega, L_\sigma = 12\text{ nH},$ diode: body diode at $V_{GS} = -5\text{ V}$	$T_{vj} = 25\text{ }^\circ\text{C}$	153		$\mu\text{J}$
			$T_{vj} = 175\text{ }^\circ\text{C}$	519		
Turn-off energy at -5 V	$E_{off}$	$V_{DD} = 1000\text{ V}, I_D = 20.4\text{ A},$ $V_{GS} = -5/18\text{ V},$ $R_{G,ext} = 2.3\ \Omega, L_\sigma = 12\text{ nH},$ diode: body diode at $V_{GS} = -5\text{ V}$	$T_{vj} = 25\text{ }^\circ\text{C}$	32		$\mu\text{J}$
			$T_{vj} = 175\text{ }^\circ\text{C}$	32		
Total switching energy at -5 V <sup>1)</sup>	$E_{tot}$	$V_{DD} = 1000\text{ V}, I_D = 20.4\text{ A},$ $V_{GS} = -5/18\text{ V},$ $R_{G,ext} = 2.3\ \Omega, L_\sigma = 12\text{ nH},$ diode: body diode at $V_{GS} = -5\text{ V}$	$T_{vj} = 25\text{ }^\circ\text{C}$	250		$\mu\text{J}$
			$T_{vj} = 175\text{ }^\circ\text{C}$	835		
Virtual junction temperature	$T_{vj}$		-55		175	$^\circ\text{C}$

1) including  $E_{fr}$

注: The chip technology was characterized up to 200 kV/ $\mu\text{s}$ . The measured  $dV/dt$  was limited by measurement test setup and package.  
Characteristics at  $T_{vj} = 25\text{ }^\circ\text{C}$ , unless otherwise specified.

### 3 Body diode (MOSFET)

表 5 最大标定值

特征参数	代号	标注或测试条件	数值	单位	
Drain-source voltage	$V_{DSS}$	$T_{vj} \geq 25\text{ }^\circ\text{C}$	1400	V	
Continuous reverse drain current for $R_{th(j-c,max)}$ , limited by $T_{vj(max)}$	$I_{SDC}$	$V_{GS} = 0\text{ V}$	$T_c = 25\text{ }^\circ\text{C}$	43	A
			$T_c = 100\text{ }^\circ\text{C}$	24	
Peak reverse drain current, $t_p$ limited by $T_{vj(max)}$	$I_{SM}$	$V_{GS} = 0\text{ V}$	111	A	

表 6 特征值

特征参数	代号	标注或测试条件		数值			单位
				最小值	典型值	最大值	
Drain-source reverse voltage	$V_{SD}$	$I_{SD} = 20.4 \text{ A}, V_{GS} = 0 \text{ V}$	$T_{vj} = 25 \text{ }^\circ\text{C}$		4.2	5.5	V
			$T_{vj} = 100 \text{ }^\circ\text{C}$		4.11		
			$T_{vj} = 175 \text{ }^\circ\text{C}$		4.05		
MOSFET forward recovery charge	$Q_{fr}$	$V_{DD} = 1000 \text{ V}, I_{SD} = 20.4 \text{ A}, V_{GS} = 0 \text{ V}, R_{GS(on)} = 2.3 \text{ } \Omega, Q_{fr}$ includes also $Q_C$	$T_{vj} = 25 \text{ }^\circ\text{C}$		0.21		$\mu\text{C}$
			$T_{vj} = 175 \text{ }^\circ\text{C}$		0.62		
MOSFET peak forward recovery current	$I_{frm}$	$V_{DD} = 1000 \text{ V}, I_{SD} = 20.4 \text{ A}, V_{GS} = 0 \text{ V}, R_{GS(on)} = 2.3 \text{ } \Omega, Q_{fr}$ includes also $Q_C$	$T_{vj} = 25 \text{ }^\circ\text{C}$		48		A
			$T_{vj} = 175 \text{ }^\circ\text{C}$		99		
MOSFET forward recovery energy	$E_{fr}$	$V_{DD} = 1000 \text{ V}, I_{SD} = 20.4 \text{ A}, V_{GS} = 0 \text{ V}, R_{GS(on)} = 2.3 \text{ } \Omega, Q_{fr}$ includes also $Q_C$	$T_{vj} = 25 \text{ }^\circ\text{C}$		65		$\mu\text{J}$
			$T_{vj} = 175 \text{ }^\circ\text{C}$		276		
MOSFET forward recovery energy at -5 V	$E_{fr}$	$V_{DD} = 1000 \text{ V}, I_{SD} = 20.4 \text{ A}, V_{GS} = -5 \text{ V}, R_{GS(on)} = 2.3 \text{ } \Omega, Q_{fr}$ includes also $Q_C$	$T_{vj} = 25 \text{ }^\circ\text{C}$		65		$\mu\text{J}$
			$T_{vj} = 175 \text{ }^\circ\text{C}$		284		
Virtual junction temperature	$T_{vj}$			-55		175	$^\circ\text{C}$

**4 特征参数图表**

**Safe operating area (SOA)**

$I_D = f(V_{DS})$

$T_{vj} \leq 175\text{ }^\circ\text{C}, T_c = 25\text{ }^\circ\text{C}$

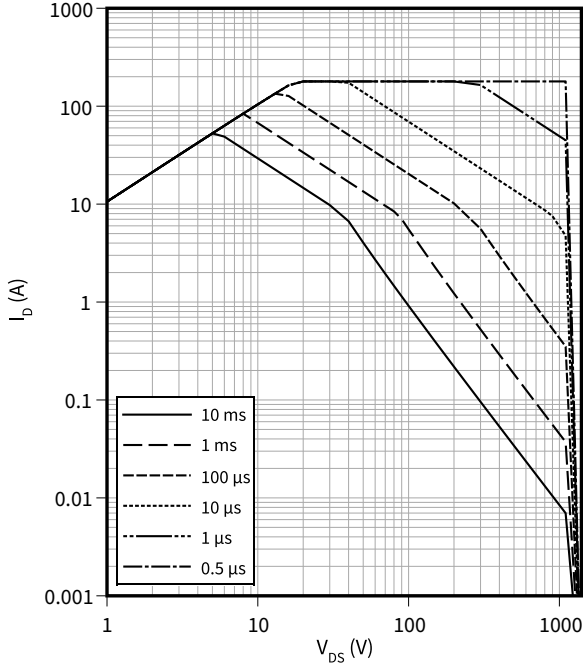

**Power dissipation as a function of case temperature**

$P_{tot} = f(T_c)$

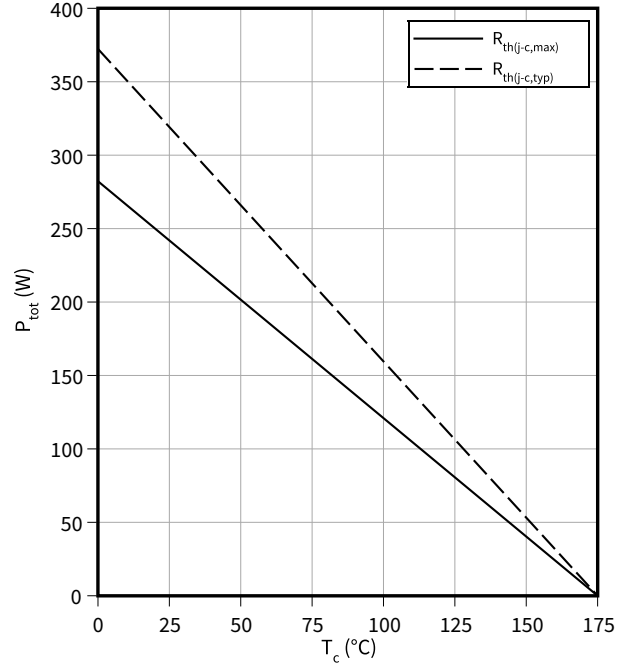

**Maximum DC drain to source current as a function of case temperature limited by bond wire**

$I_D = f(T_c)$

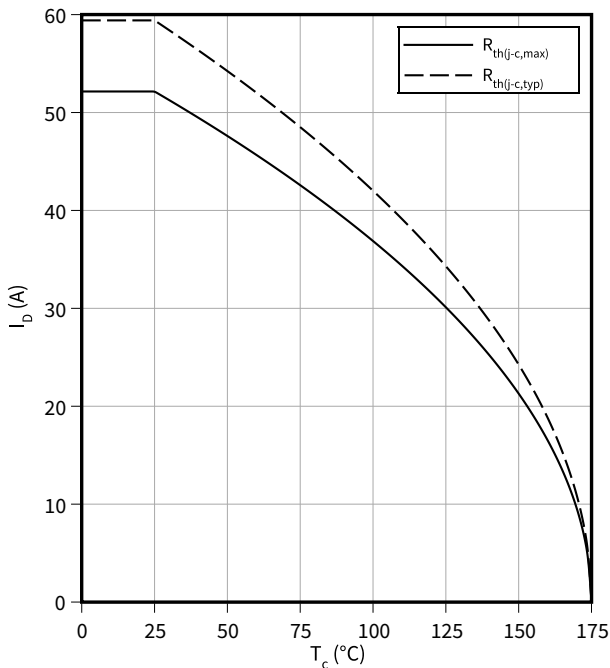

**Maximum source to drain current as a function of case temperature limited by bond wire**

$I_{SD} = f(T_c)$

$V_{GS} = 0\text{ V}$

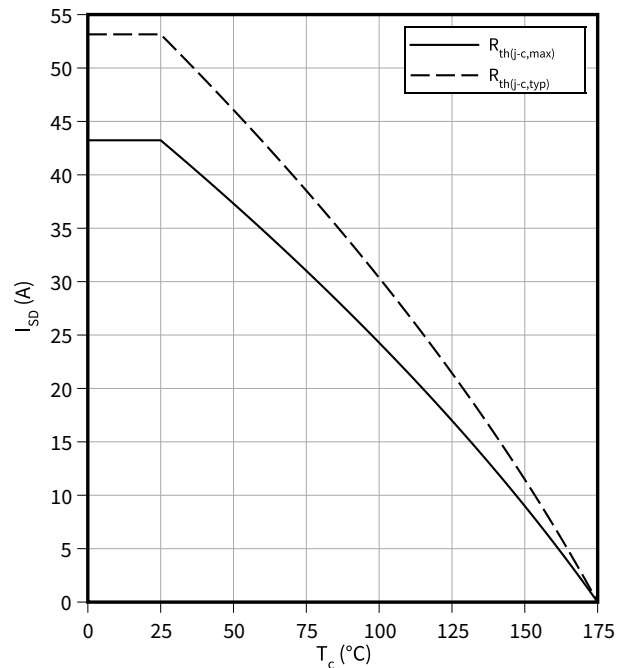

4 特征参数图表

**Typical transfer characteristic**

$I_D = f(V_{GS})$   
 $V_{DS} = 20\text{ V}$ ,  $t_p = 20\ \mu\text{s}$

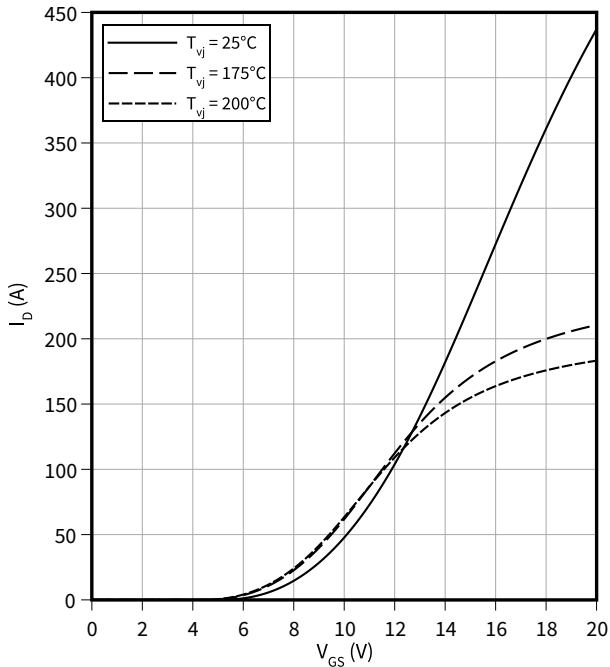

**Typical gate-source threshold voltage as a function of junction temperature**

$V_{GS(th)} = f(T_{vj})$   
 $I_D = 6.4\text{ mA}$

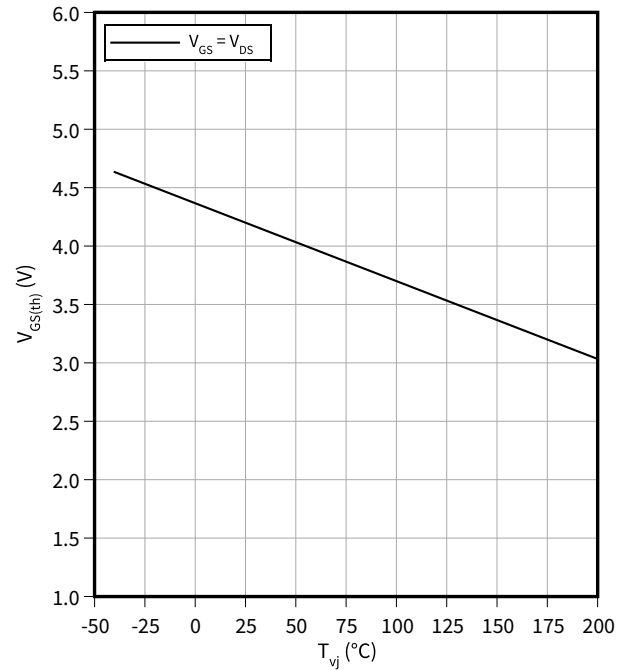

**Typical output characteristic,  $V_{GS}$  as a parameter**

$I_D = f(V_{DS})$   
 $T_{vj} = 25\ ^\circ\text{C}$ ,  $t_p = 20\ \mu\text{s}$

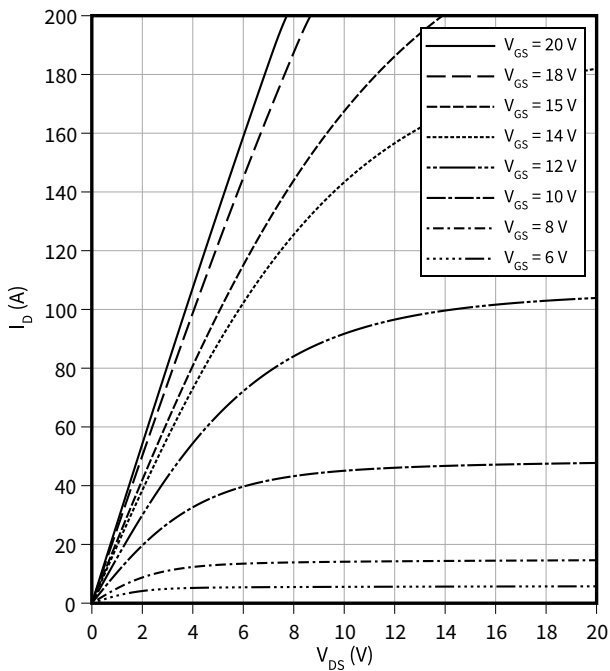

**Typical output characteristic,  $V_{GS}$  as a parameter**

$I_D = f(V_{DS})$   
 $T_{vj} = 175\ ^\circ\text{C}$ ,  $t_p = 20\ \mu\text{s}$

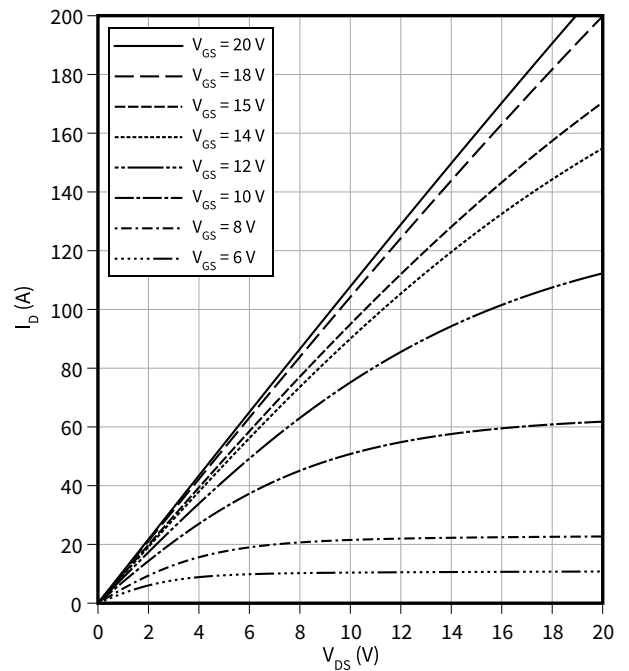

4 特征参数图表

**Typical on-state resistance as a function of junction temperature**

$R_{DS(on)} = f(T_{vj})$   
 $I_D = 20.4 \text{ A}$

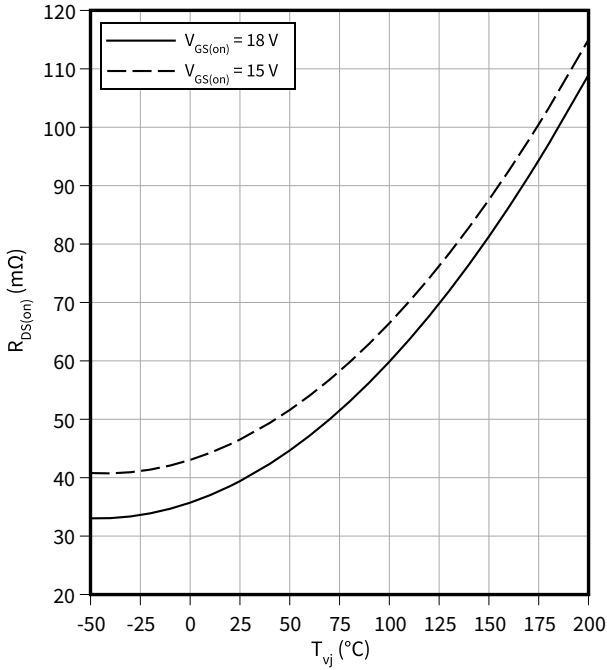

**Typical gate charge**

$V_{GS} = f(Q_G)$   
 $I_D = 20.4 \text{ A}, V_{DS} = 1000 \text{ V}$

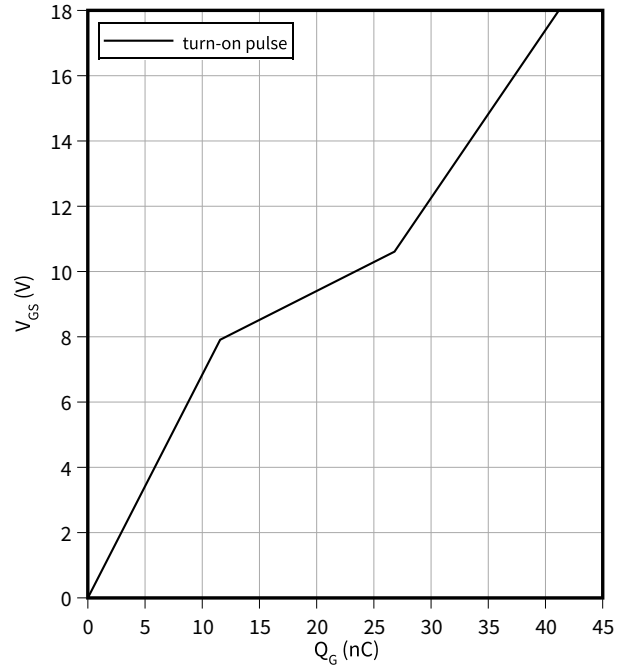

**Typical capacitance as a function of drain-source voltage**

$C = f(V_{DS})$   
 $f = 100 \text{ kHz}, V_{GS} = 0 \text{ V}$

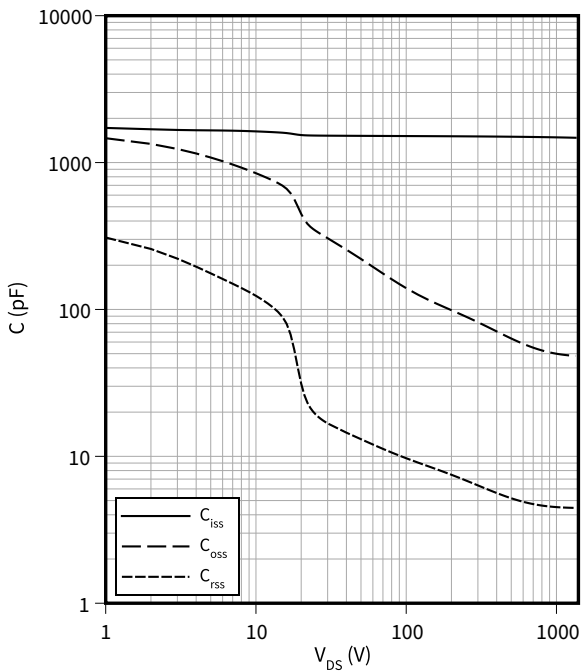

**Typical reverse drain voltage as a function of junction temperature**

$V_{SD} = f(T_{vj})$   
 $I_{SD} = 20.4 \text{ A}, V_{GS} = 0 \text{ V}$

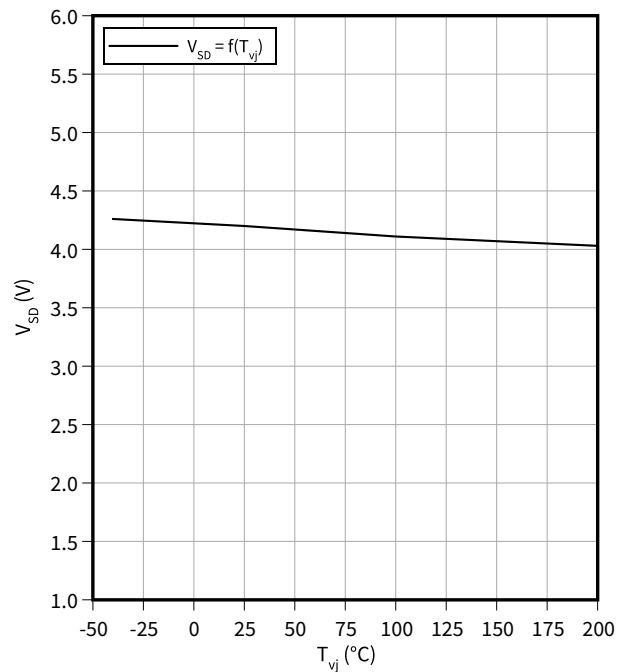

4 特征参数图表

**Typical reverse drain current as a function of reverse drain voltage,  $V_{GS}$  as a parameter**

$I_{SD} = f(V_{SD})$   
 $T_{vj} = 25\text{ }^{\circ}\text{C}$ ,  $t_p = 20\text{ }\mu\text{s}$

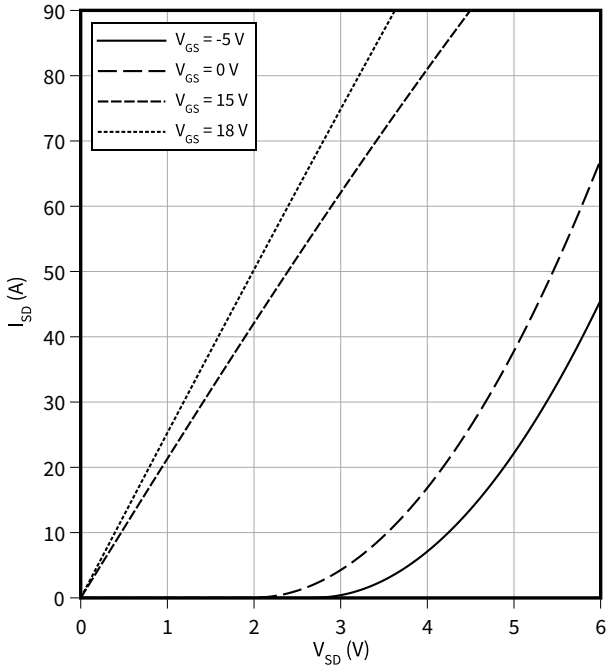

**Typical reverse drain current as a function of reverse drain voltage,  $V_{GS}$  as a parameter**

$I_{SD} = f(V_{SD})$   
 $T_{vj} = 175\text{ }^{\circ}\text{C}$ ,  $t_p = 20\text{ }\mu\text{s}$

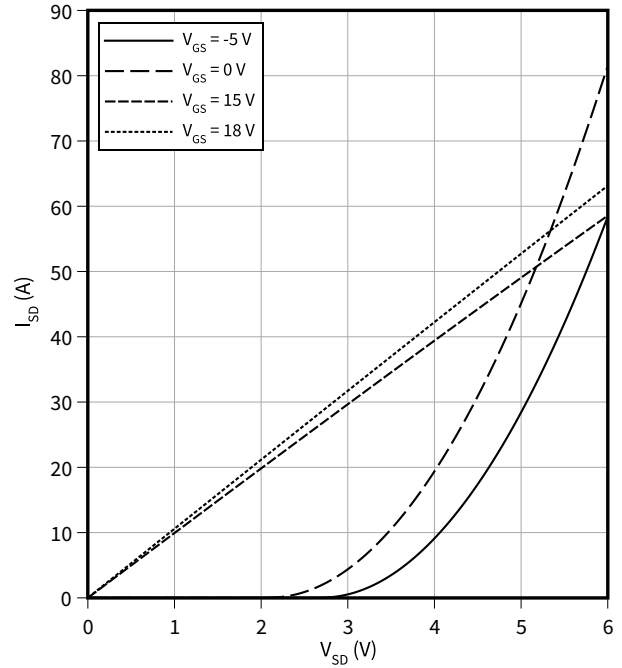

**Typical switching energy as a function of junction temperature, test circuit in Fig. F, 2nd device own body diode:  $V_{GS} = 0\text{ V}$**

$E = f(T_{vj})$   
 $V_{GS} = 0/18\text{ V}$ ,  $I_D = 20.4\text{ A}$ ,  $R_{G,ext} = 2.3\text{ }\Omega$ ,  $V_{DD} = 1000\text{ V}$

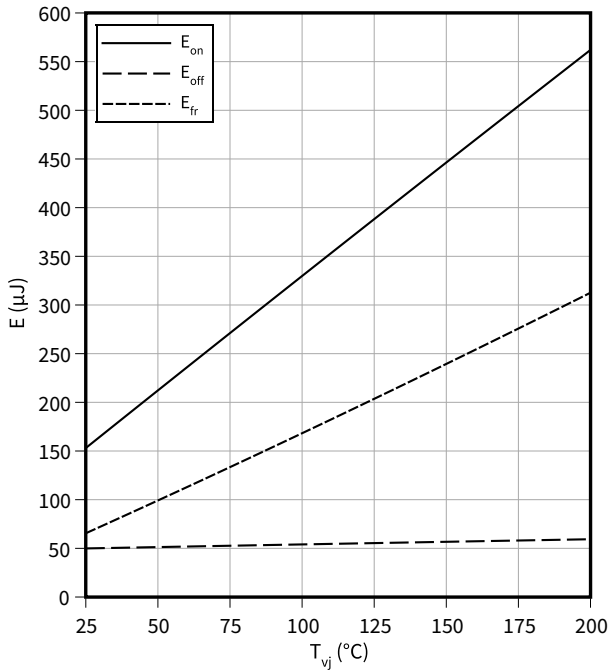

**Typical switching energy as a function of junction temperature, test circuit in Fig. F, 2nd device own body diode:  $V_{GS} = -5\text{ V}$**

$E = f(T_{vj})$   
 $V_{GS} = -5/18\text{ V}$ ,  $I_D = 20.4\text{ A}$ ,  $R_{G,ext} = 2.3\text{ }\Omega$ ,  $V_{DD} = 1000\text{ V}$

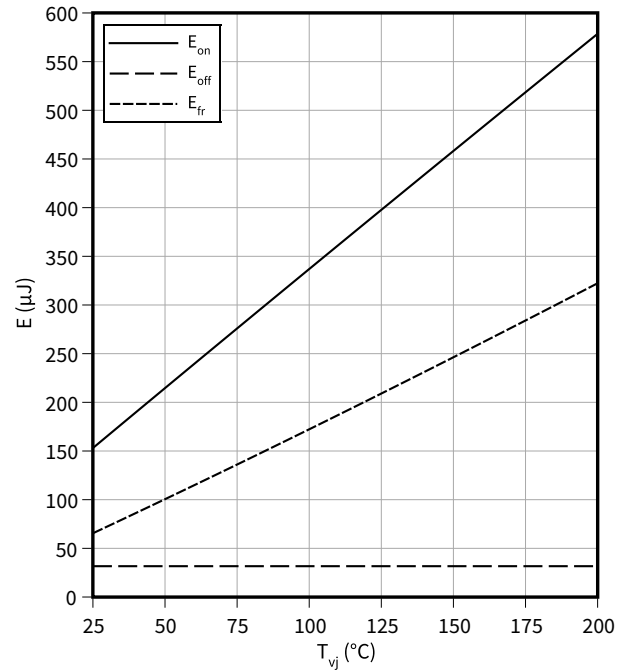

4 特征参数图表

**Typical switching energy as a function of drain current, test circuit in Fig. F, 2nd device own body diode:  $V_{GS} = 0\text{ V}$**

$E = f(I_D)$

$V_{GS} = 0/18\text{ V}$ ,  $T_{vj} = 175\text{ °C}$ ,  $R_{G,ext} = 2.3\ \Omega$ ,  $V_{DD} = 1000\text{ V}$

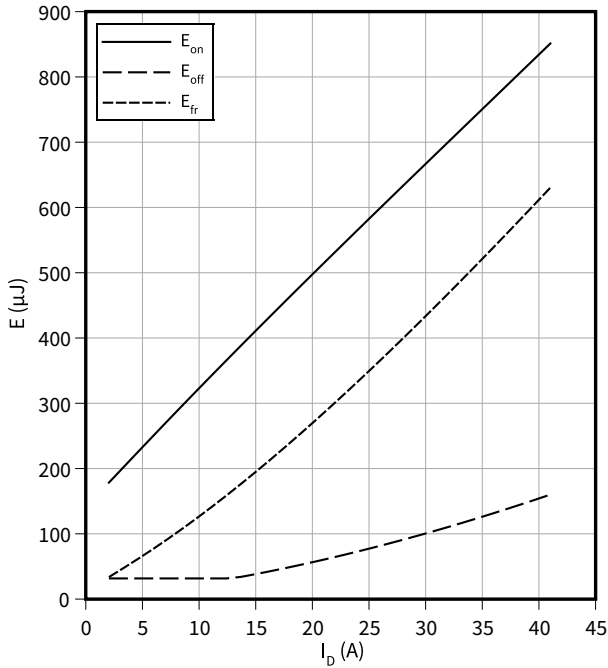

**Typical switching energy as a function of drain current, test circuit in Fig. F, 2nd device own body diode:  $V_{GS} = -5\text{ V}$**

$E = f(I_D)$

$V_{GS} = -5/18\text{ V}$ ,  $T_{vj} = 175\text{ °C}$ ,  $R_{G,ext} = 2.3\ \Omega$ ,  $V_{DD} = 1000\text{ V}$

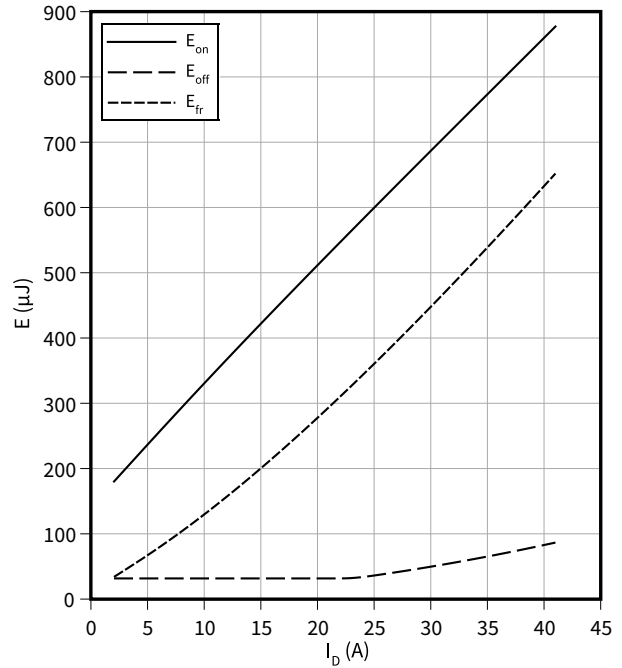

**Typical switching energy as a function of gate resistance, test circuit in Fig. F, 2nd device own body diode:  $V_{GS} = 0\text{ V}$**

$E = f(R_{G,ext})$

$V_{GS} = 0/18\text{ V}$ ,  $I_D = 20.4\text{ A}$ ,  $T_{vj} = 175\text{ °C}$ ,  $V_{DD} = 1000\text{ V}$

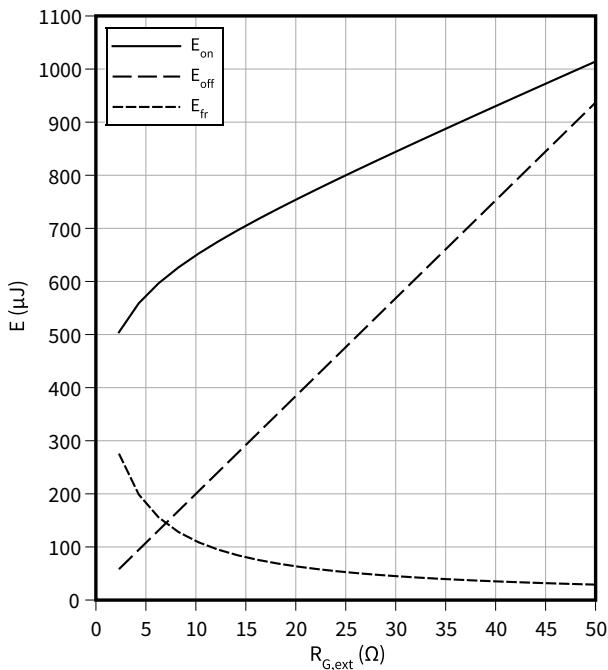

**Typical switching energy as a function of gate resistance, test circuit in Fig. F, 2nd device own body diode:  $V_{GS} = -5\text{ V}$**

$E = f(R_{G,ext})$

$V_{GS} = -5/18\text{ V}$ ,  $I_D = 20.4\text{ A}$ ,  $T_{vj} = 175\text{ °C}$ ,  $V_{DD} = 1000\text{ V}$

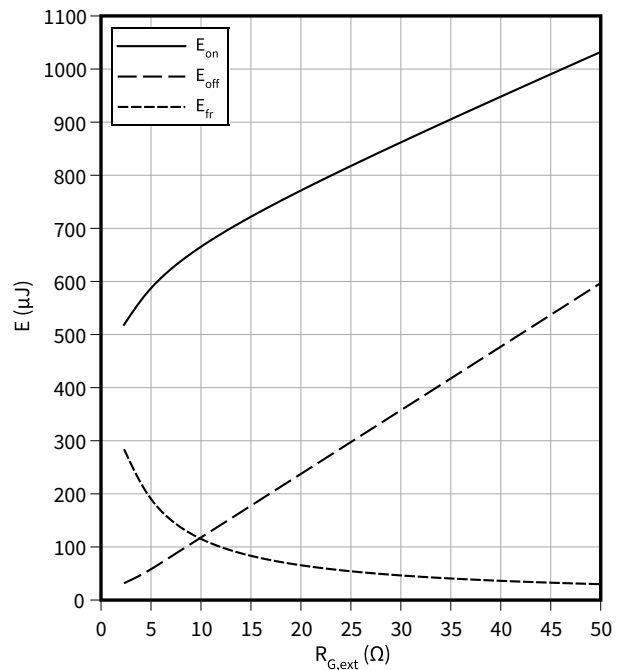

4 特征参数图表

**Typical switching energy as a function of DC link voltage, test circuit in Fig. F, 2nd device own body diode:  $V_{GS} = 0\text{ V}$**

$E = f(V_{DD})$

$V_{GS} = 0/18\text{ V}$ ,  $I_D = 20.4\text{ A}$ ,  $T_{vj} = 175\text{ °C}$ ,  $R_{G,ext} = 2.3\text{ }\Omega$

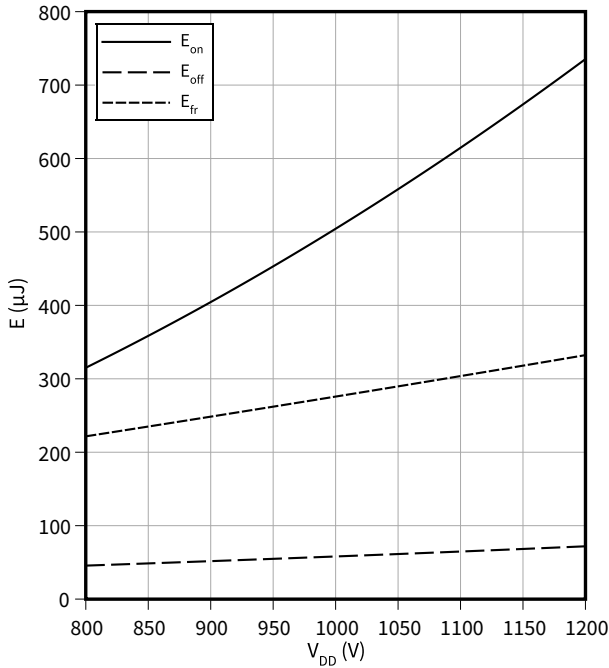

**Typical switching energy as a function of DC link voltage, test circuit in Fig. F, 2nd device own body diode:  $V_{GS} = -5\text{ V}$**

$E = f(V_{DD})$

$V_{GS} = -5/18\text{ V}$ ,  $I_D = 20.4\text{ A}$ ,  $T_{vj} = 175\text{ °C}$ ,  $R_{G,ext} = 2.3\text{ }\Omega$

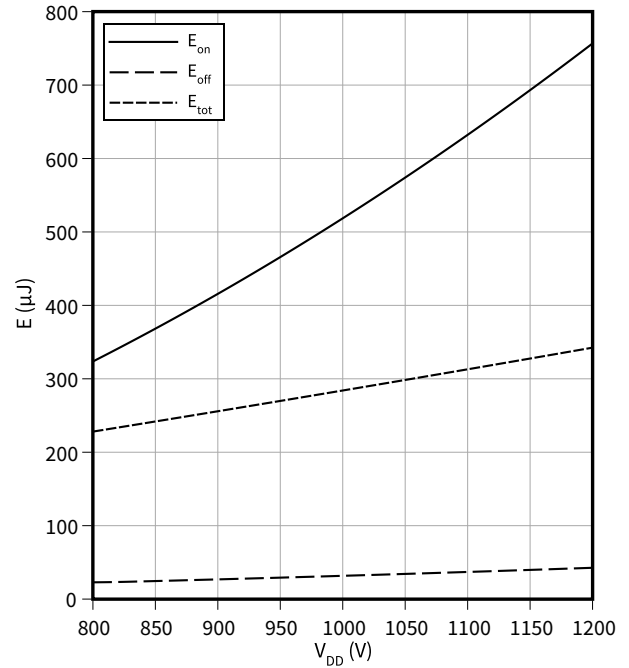

**Typical switching times as a function of gate resistance, test circuit in Fig. F, 2nd device own body diode:  $V_{GS} = 0\text{ V}$**

$t = f(R_{G,ext})$

$V_{GS} = 0/18\text{ V}$ ,  $I_D = 20.4\text{ A}$ ,  $T_{vj} = 175\text{ °C}$ ,  $V_{DD} = 1000\text{ V}$

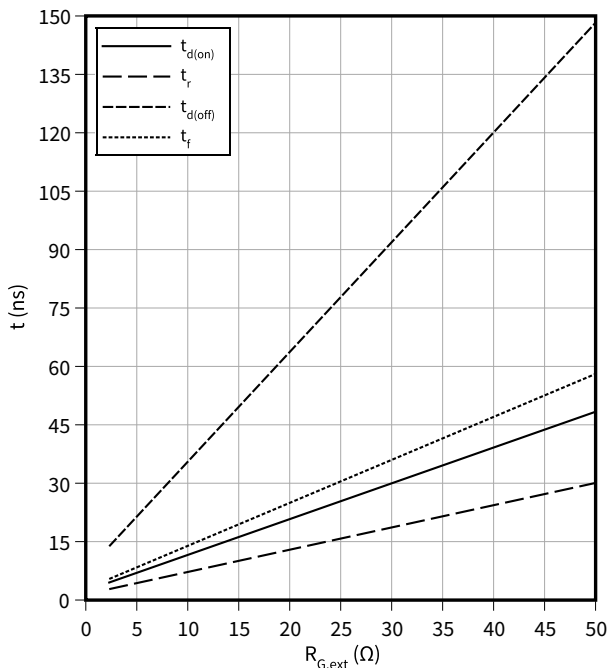

**Typical reverse recovery charge as a function of reverse drain current slope, test circuit in Fig. F, 2nd device own body diode:  $V_{GS} = 0\text{ V}$**

$Q_{fr} = f(-di_{SD}/dt)$

$V_{GS} = 0/18\text{ V}$ ,  $I_{SD} = 20.4\text{ A}$ ,  $V_{DD} = 1000\text{ V}$

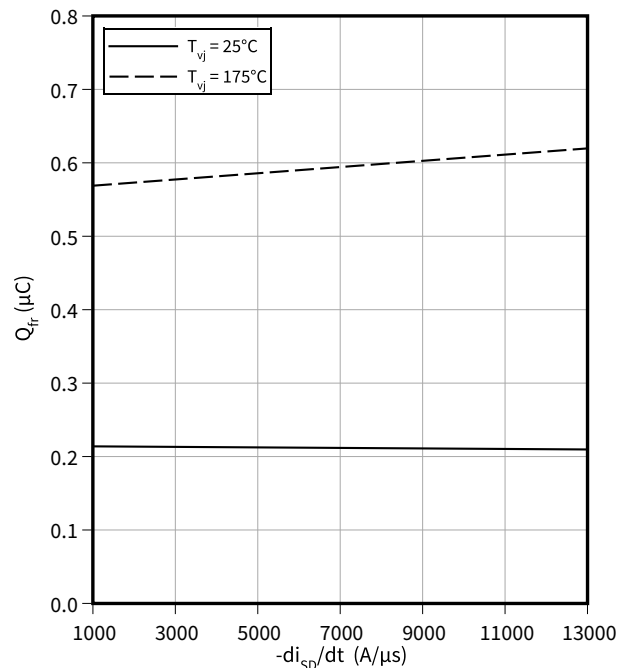

4 特征参数图表

**Typical reverse recovery current as a function of reverse drain current slope, test circuit in Fig. F, 2nd device own body diode:  $V_{GS} = 0\text{ V}$**

$$I_{frm} = f(-di_{SD}/dt)$$

$V_{GS} = 0/18\text{ V}$ ,  $I_{SD} = 20.4\text{ A}$ ,  $V_{DD} = 1000\text{ V}$

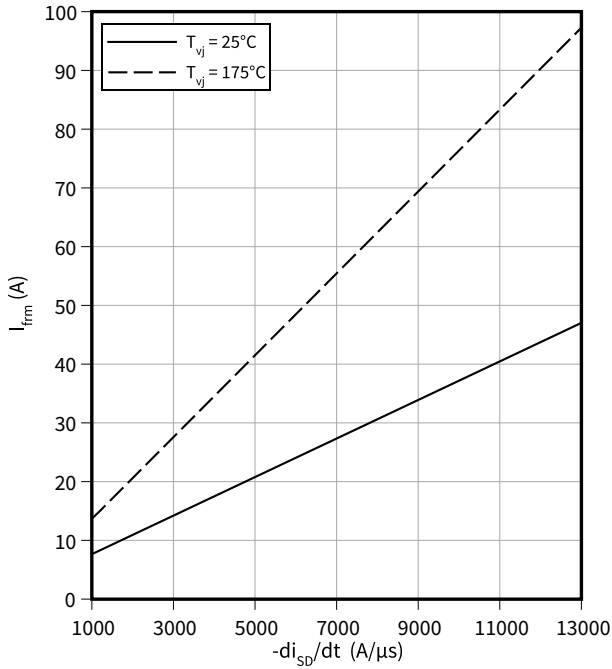

**Typical switching energy as a function of dead time / blanking time, test circuit in Fig. F, 2nd device own body diode:  $V_{GS} = 0\text{ V}$**

$$E = f(t_{dead})$$

$V_{GS} = 0/18\text{ V}$ ,  $I_D = 20.4\text{ A}$ ,  $T_{vj} = 175\text{ °C}$ ,  $R_{G,ext} = 2.3\text{ }\Omega$   
 $V_{DD} = 1000\text{ V}$

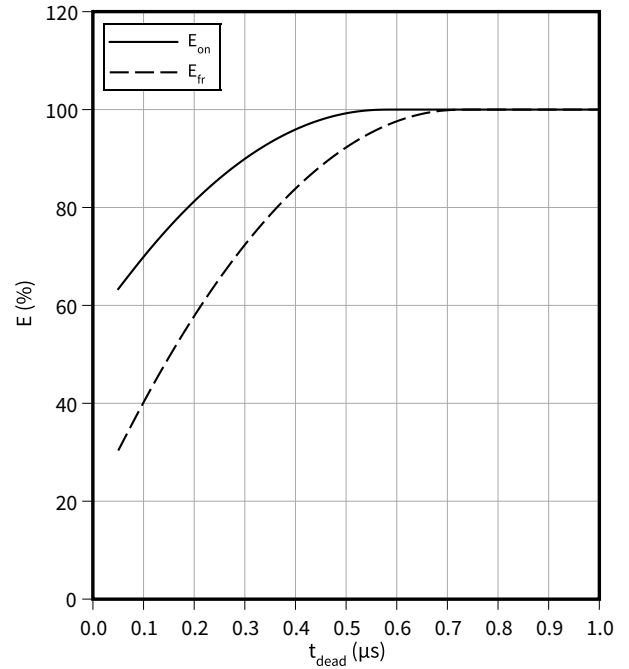

**Max. transient thermal impedance (MOSFET/diode)**

$$Z_{th(j-c),max} = f(t_p)$$

$$D = t_p/T$$

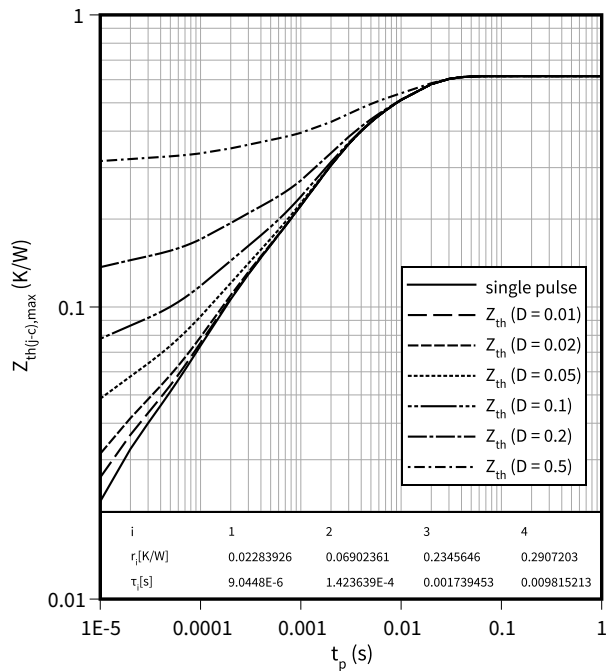

5 封装尺寸

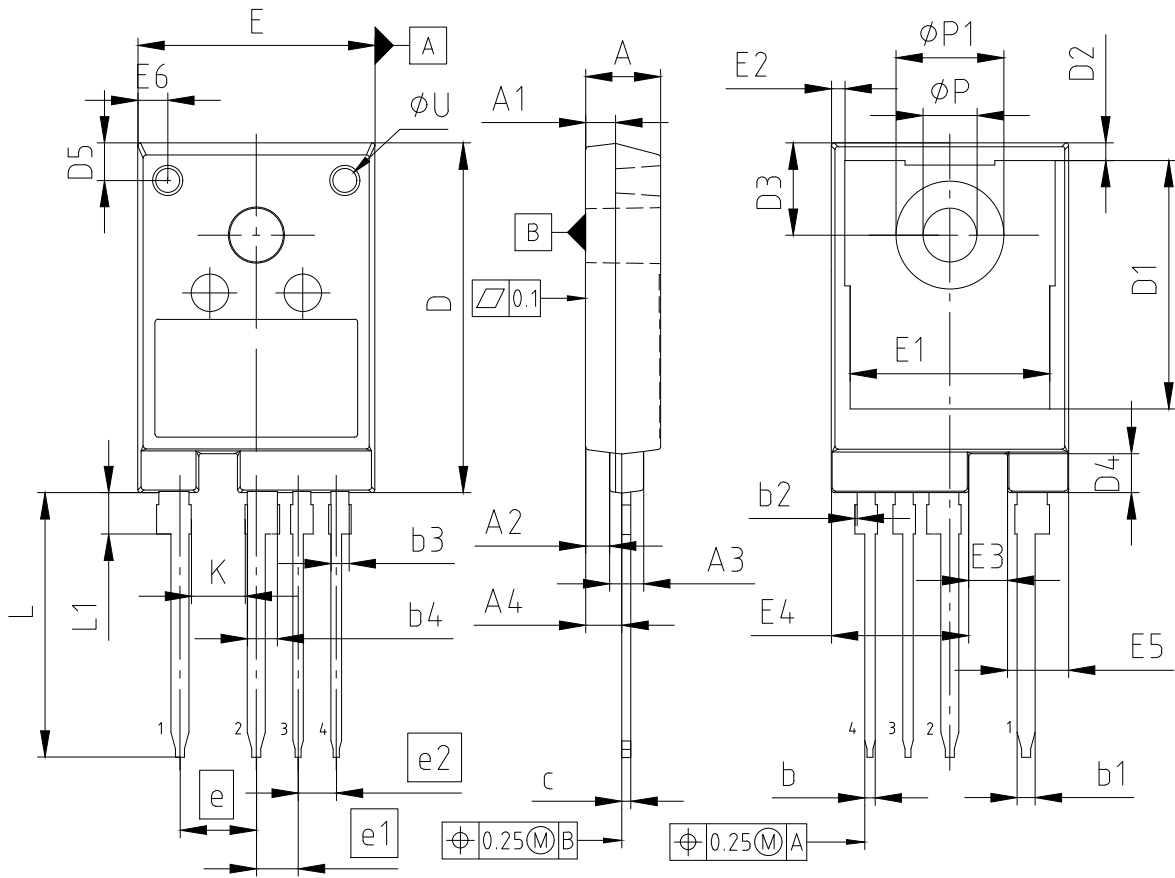

PACKAGE - GROUP NUMBER: **PG-T0247-4-U07**

DIMENSIONS	MILLIMETERS		DIMENSIONS	MILLIMETERS	
	MIN.	MAX.		MIN.	MAX.
<b>A</b>	4.90	5.10	<b>E</b>	15.60	16.00
<b>A1</b>	1.90	2.10	<b>E1</b>	13.10	13.50
<b>A2</b>	1.50	1.70	<b>E2</b>	0.60	1.20
<b>A3</b>	2.16	2.36	<b>E3</b>	2.48	2.68
<b>A4</b>	2.31	2.51	<b>E4</b>	9.05	9.25
<b>b</b>	0.60	0.80	<b>E5</b>	3.97	4.17
<b>b1</b>	1.10	1.30	<b>E6</b>	1.80	2.20
<b>b2</b>	---	0.15	<b>e</b>	5.08	
<b>b3</b>	1.10	1.30	<b>e1</b>	2.79	
<b>b4</b>	1.90	2.10	<b>e2</b>	2.54	
<b>c</b>	0.50	0.70	<b>K</b>	3.50	---
<b>D</b>	23.10	23.50	<b>L</b>	17.50	17.80
<b>D1</b>	16.25	16.85	<b>L1</b>	2.61	2.91
<b>D2</b>	0.97	1.37	<b>N</b>	4	
<b>D3</b>	6.00	6.30	<b>ØP1</b>	7.00	7.40
<b>D4</b>	2.50	2.70	<b>ØP</b>	3.50	3.70
<b>D5</b>	2.30	2.70	<b>ØU</b>	1.40	1.80

NOTES: DIMENSIONS DO NOT INCLUDE MOLD FLASH, PROTRUSION OR GATE BURRS  
N IS THE NUMBER OF LEADS

图 1

## 6 Testing conditions

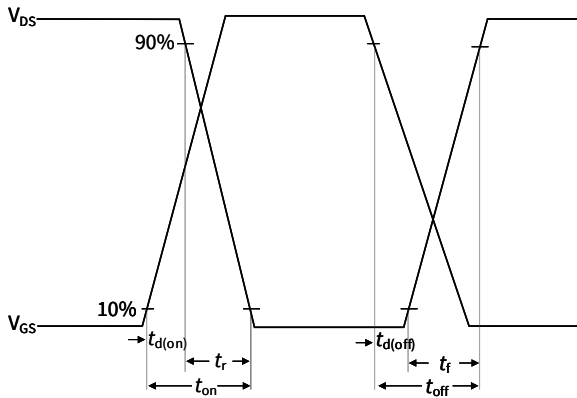

Figure A. Definition of switching times

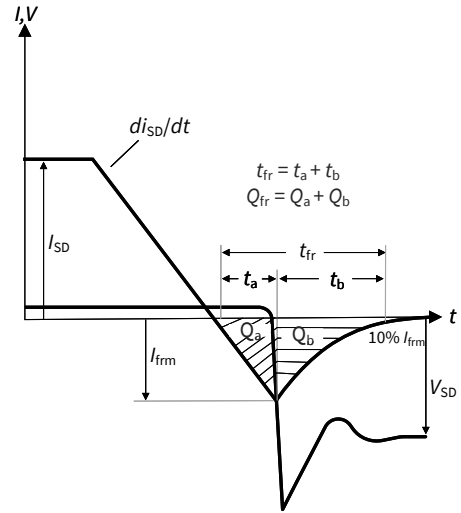

Figure B. Definition of body diode switching characteristics

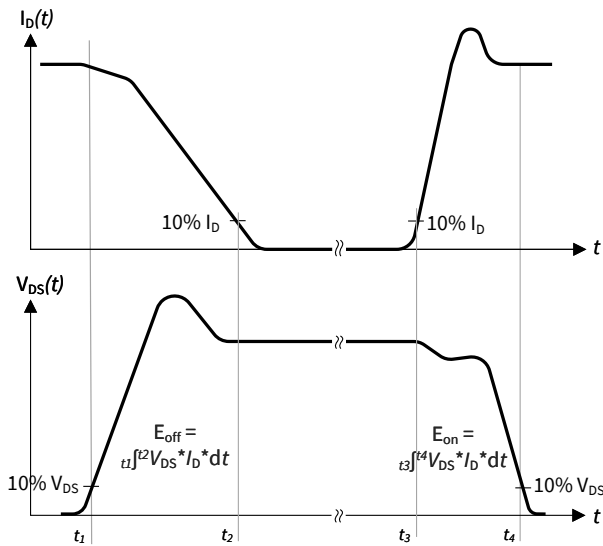

Figure C. Definition of switching losses

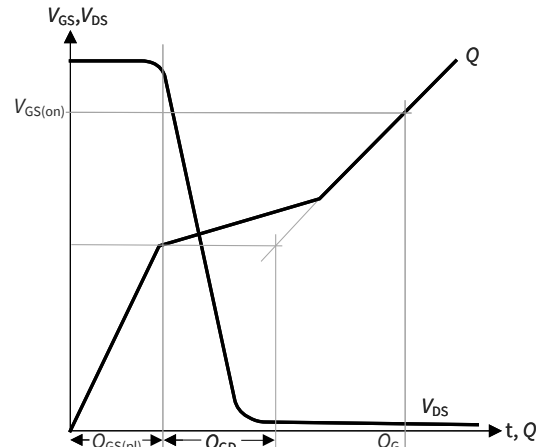

Figure D. Definition of QGD

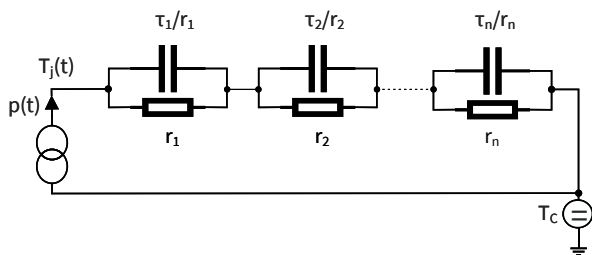

Figure E. Thermal equivalent circuit

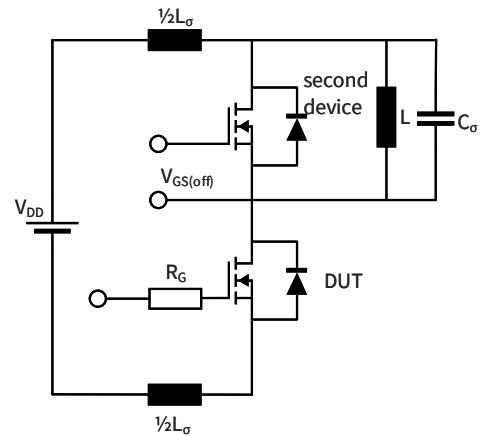

Figure F. Dynamic test circuit

Parasitic inductance  $L_\sigma$ ,  
Parasitic capacitor  $C_\sigma$ ,

修订历史

## 修订历史

修订版本	发布日期	变更说明
0.10	2025-05-28	Preliminary datasheet
1.00	2025-06-12	Final datasheet

## Trademarks

All referenced product or service names and trademarks are the property of their respective owners.

**Edition 2025-06-12**

**Published by**

**Infineon Technologies AG**

**81726 Munich, Germany**

**© 2025 Infineon Technologies AG**

**All Rights Reserved.**

**Do you have a question about any aspect of this document?**

**Email: [erratum@infineon.com](mailto:erratum@infineon.com)**

**Document reference**

**IFX-ABM913-002**

## 重要提示

本文档所提供的任何信息绝不应被视为针对任何条件或者品质而做出的保证（质量保证）。

英飞凌对于本文档中所提及的任何事例、提示或者任何特定数值及/或任何关于产品应用方面的信息均在此明确声明其不承担任何保证或者责任，包括但不限于其不侵犯任何第三方知识产权的保证均在此排除。

此外，本文档所提供的任何信息均取决于客户履行本文档所载明的义务和客户遵守适用于客户产品以及与客户对于英飞凌产品的应用所相关的任何法律要求、规范和标准。

本文档所含的数据仅供经过专业技术培训的人员使用。客户自身的技术部门有义务对于产品是否适宜于其预期的应用和针对该等应用而言本文档中所提供的信息是否充分自行予以评估。

请注意本产品不符合汽车电子协会制定的车电可靠度验证 AEC Q 100 或 AEC Q101 标准的要求。

## 警告事项

由于技术所需产品可能含有危险物质。如需了解该等物质的类型，请向离您最近的英飞凌科技办公室接洽。

除非由经英飞凌科技授权代表签署的书面文件中做出另行明确批准的情况外，英飞凌科技的产品不应被用于任何一项一旦产品失效或者产品使用的后当被用于任何一项一旦产品失效或者产品使用的后领域。