

Final datasheet

CoolSiC™ Hybrid Discrete : CoolSiC™ 1200 V SiC MOSFET G2 co-packed with soft, fast recovery Emitter Controlled 7 diode for reverse-polarity protection

Features

- $V_{DSS} = 1200\text{ V}$ at $T_{vj} = 25^\circ\text{C}$
- $I_{DDC} = 56\text{ A}$ at $T_c = 100^\circ\text{C}$
- $R_{DS(on)} = 18\text{ m}\Omega$ at $V_{GS} = 18\text{ V}$, $T_{vj} = 25^\circ\text{C}$
- Reverse-polarity protection diode with $I_F = 81\text{ A}$ at $T_c = 100^\circ\text{C}$
- Very low switching losses
- Optimized for MPPT boost converter in solar applications
- Benchmark gate threshold voltage, $V_{GS(th)} = 4.2\text{ V}$
- Robust against parasitic turn on, 0 V turn-off gate voltage can be applied
- Soft and low Q_{rr} diode with $V_F = 1.6\text{ V}$ at $T_c = 175^\circ\text{C}$
- Suitable Infineon gate drivers can be found under <https://www.infineon.com/gdfinder>

Potential applications

- String inverter

Product validation

- Qualified for industrial applications according to the relevant tests of JEDEC47/20/22

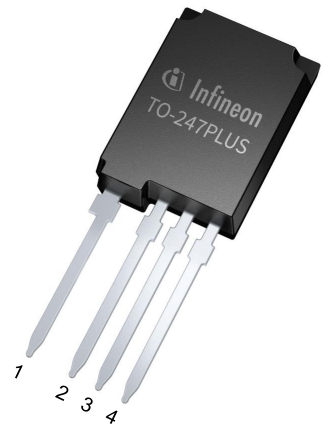

- Halogen-free
- Green
- Lead-free
- RoHS

Description

Pin definition:

- 1 – Drain
- 2 – Source
- 3 – Kelvin sense contact
- 4 – Gate

Note: the source and sense pins are not exchangeable, their exchange might lead to malfunction (only for 4pin, TO263-7L)

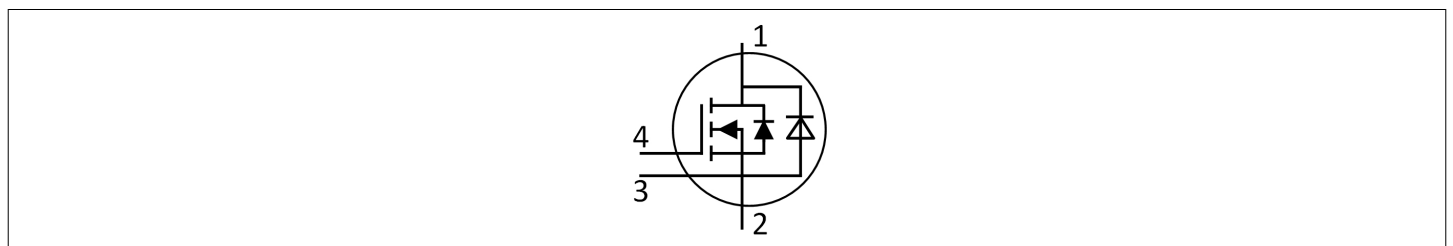

Type	Package	Marking
IMY120R018CM2H	PG-TO247-4-U10	12M2HC018

Table of contents

	Description	1
	Features	1
	Potential applications	1
	Product validation	1
	Table of contents	2
1	Package	3
2	MOSFET	3
3	Reverse-polarity protection diode	5
4	Characteristics diagrams	7
5	Package outlines	15
6	Testing conditions	16
	Revision history	17
	Disclaimer	18

1 Package

Table 1 Characteristic values

Parameter	Symbol	Note or test condition	Values			Unit
			Min.	Typ.	Max.	
Storage temperature	T_{stg}		-55		150	°C
Soldering temperature	T_{sold}	Wave soldering 1.6 mm (0.063 in.) from case for 10 s			260	°C
Thermal resistance, junction-ambient	$R_{th(j-a)}$				62	K/W
MOSFET thermal resistance, junction-case	$R_{th(j-c)}$			0.41	0.53	K/W
Reverse-polarity protection diode thermal resistance, junction-case	$R_{th(j-c)}$			0.31	0.42	K/W
Comparative Tracking Index	CTI	IEC 60112 (material group 1 according to IEC 60664-1)	600			V

2 MOSFET

Table 2 Maximum rated values

Parameter	Symbol	Note or test condition	Values	Unit	
Drain-source voltage	V_{DSS}	$T_{vj} \geq 25\text{ °C}$	1200	V	
Continuous DC drain current for $R_{th(j-c,max)}$, limited by $T_{vj(max)}$	I_{DDC}	$V_{GS} = 18\text{ V}$	$T_c = 25\text{ °C}$	80	A
			$T_c = 100\text{ °C}$	56	
Peak drain current, t_p limited by $T_{vj(max)}$ ¹⁾	I_{DM}	$V_{GS} = 18\text{ V}$	280	A	
Gate-source voltage, max. transient voltage ²⁾	V_{GS}	$t_p \leq 0.5\ \mu\text{s}, D < 0.01$	-10...25	V	
Gate-source voltage, max. static voltage	V_{GS}		-7...23	V	
Power dissipation, limited by $T_{vj(max)}$	P_{tot}		$T_c = 25\text{ °C}$	280	W
			$T_c = 100\text{ °C}$	141	

1) Verified by design

2) The maximum gate-source voltage in the application design should be in accordance to IPC-9592B.

Table 3 Recommended values

Parameter	Symbol	Note or test condition	Values	Unit
Recommended turn-on gate voltage	$V_{GS(on)}$		15...18	V
Recommended turn-off gate voltage	$V_{GS(off)}$		-5...0	V

Table 4 Characteristic values

Parameter	Symbol	Note or test condition	Values			Unit	
			Min.	Typ.	Max.		
Drain-source on-state resistance	$R_{DS(on)}$	$I_D = 37.4 \text{ A}$	$T_{vj} = 25 \text{ }^\circ\text{C}$, $V_{GS(on)} = 18 \text{ V}$		18	23	mΩ
			$T_{vj} = 150 \text{ }^\circ\text{C}$, $V_{GS(on)} = 18 \text{ V}$		37		
			$T_{vj} = 175 \text{ }^\circ\text{C}$, $V_{GS(on)} = 18 \text{ V}$		43		
			$T_{vj} = 25 \text{ }^\circ\text{C}$, $V_{GS(on)} = 15 \text{ V}$		23		
Gate-source threshold voltage	$V_{GS(th)}$	$I_D = 11.8 \text{ mA}$, $V_{DS} = V_{GS}$ (tested after 1 ms pulse at $V_{GS} = 20 \text{ V}$)	$T_{vj} = 25 \text{ }^\circ\text{C}$	3.5	4.2	5.1	V
			$T_{vj} = 175 \text{ }^\circ\text{C}$		3.2		
Zero gate-voltage drain current	I_{DSS}	$V_{DS} = 1200 \text{ V}$, $V_{GS} = 0 \text{ V}$	$T_{vj} = 25 \text{ }^\circ\text{C}$			350	μA
			$T_{vj} = 175 \text{ }^\circ\text{C}$		957		
Gate leakage current	I_{GSS}	$V_{DS} = 0 \text{ V}$	$V_{GS} = 23 \text{ V}$			120	nA
			$V_{GS} = -10 \text{ V}$			-120	
Forward transconductance	g_{fs}	$I_D = 37.4 \text{ A}$, $V_{DS} = 20 \text{ V}$		28.6		S	
Internal gate resistance	$R_{G,int}$	$f = 1 \text{ MHz}$, $V_{AC} = 25 \text{ mV}$		2.2		Ω	
Input capacitance	C_{iss}	$V_{DS} = 800 \text{ V}$, $V_{GS} = 0 \text{ V}$, $f = 100 \text{ kHz}$, $V_{AC} = 25 \text{ mV}$		2885		pF	
Output capacitance	C_{oss}	$V_{DS} = 800 \text{ V}$, $V_{GS} = 0 \text{ V}$, $f = 100 \text{ kHz}$, $V_{AC} = 25 \text{ mV}$		134		pF	
Reverse transfer capacitance	C_{rss}	$V_{DS} = 800 \text{ V}$, $V_{GS} = 0 \text{ V}$, $f = 100 \text{ kHz}$, $V_{AC} = 25 \text{ mV}$		7.9		pF	
C_{oss} stored energy	E_{oss}	Calculated based on $C_{oss} = f(V_{DD})$		54		μJ	
Output charge	Q_{oss}	Calculated based on $C_{oss} = f(V_{DD})$		197		nC	
Effective output capacitance, energy related	$C_{o(er)}$	$V_{DS} = 0 \dots 800 \text{ V}$, $V_{GS} = 0 \text{ V}$, Calculated based on E_{oss}		169		pF	
Effective output capacitance, time related	$C_{o(tr)}$	$I_D = \text{constant}$, $V_{DS} = 0 \dots 800 \text{ V}$, $V_{GS} = 0 \text{ V}$, Calculated based on Q_{oss}		246		pF	
Total gate charge	Q_G	$V_{DD} = 800 \text{ V}$, $I_D = 37.4 \text{ A}$, $V_{GS} = 0/18 \text{ V}$, turn-on pulse		73		nC	
Plateau gate charge	$Q_{GS(pl)}$	$V_{DD} = 800 \text{ V}$, $I_D = 37.4 \text{ A}$, $V_{GS} = 0/18 \text{ V}$, turn-on pulse		16.3		nC	
Gate-drain charge	Q_{GD}	$V_{DD} = 800 \text{ V}$, $I_D = 37.4 \text{ A}$, $V_{GS} = 0/18 \text{ V}$, turn-on pulse		16.8		nC	
Turn-on delay time	$t_{d(on)}$	$V_{DD} = 800 \text{ V}$, $I_D = 37.4 \text{ A}$, $V_{GS} = 0/18 \text{ V}$, $R_{G,ext} = 2.8 \text{ } \Omega$, $L_\sigma = 12 \text{ nH}$	$T_{vj} = 25 \text{ }^\circ\text{C}$		14		ns
			$T_{vj} = 175 \text{ }^\circ\text{C}$		13.6		

(table continues...)

Table 4 (continued) Characteristic values

Parameter	Symbol	Note or test condition	Values			Unit
			Min.	Typ.	Max.	
Rise time	t_r	$V_{DD} = 800\text{ V}, I_D = 37.4\text{ A},$ $V_{GS} = 0/18\text{ V},$ $R_{G,ext} = 2.8\ \Omega, L_\sigma = 12\text{ nH}$	$T_{vj} = 25\text{ }^\circ\text{C}$	14		ns
			$T_{vj} = 175\text{ }^\circ\text{C}$	13.6		
Turn-off delay time	$t_{d(off)}$	$V_{DD} = 800\text{ V}, I_D = 37.4\text{ A},$ $V_{GS} = 0/18\text{ V},$ $R_{G,ext} = 2.8\ \Omega, L_\sigma = 12\text{ nH}$	$T_{vj} = 25\text{ }^\circ\text{C}$	26.8		ns
			$T_{vj} = 175\text{ }^\circ\text{C}$	31.6		
Fall time	t_f	$V_{DD} = 800\text{ V}, I_D = 37.4\text{ A},$ $V_{GS} = 0/18\text{ V},$ $R_{G,ext} = 2.8\ \Omega, L_\sigma = 12\text{ nH}$	$T_{vj} = 25\text{ }^\circ\text{C}$	11.2		ns
			$T_{vj} = 175\text{ }^\circ\text{C}$	12.8		
Turn-on energy	E_{on}	$V_{DD} = 800\text{ V}, I_D = 37.4\text{ A},$ $V_{GS} = 0/18\text{ V},$ $R_{G,ext} = 2.8\ \Omega, L_\sigma = 12\text{ nH}$	$T_{vj} = 25\text{ }^\circ\text{C}$	381		μJ
			$T_{vj} = 175\text{ }^\circ\text{C}$	392		
Turn-off energy	E_{off}	$V_{DD} = 800\text{ V}, I_D = 37.4\text{ A},$ $V_{GS} = 0/18\text{ V},$ $R_{G,ext} = 2.8\ \Omega, L_\sigma = 12\text{ nH}$	$T_{vj} = 25\text{ }^\circ\text{C}$	74		μJ
			$T_{vj} = 175\text{ }^\circ\text{C}$	76		
Total switching energy	E_{tot}	$V_{DD} = 800\text{ V}, I_D = 37.4\text{ A},$ $V_{GS} = 0/18\text{ V},$ $R_{G,ext} = 2.8\ \Omega, L_\sigma = 12\text{ nH}$	$T_{vj} = 25\text{ }^\circ\text{C}$	455		μJ
			$T_{vj} = 175\text{ }^\circ\text{C}$	468		
Turn-on energy at -5 V	E_{on}	$V_{DD} = 800\text{ V}, I_D = 37.4\text{ A},$ $V_{GS} = -5/18\text{ V},$ $R_{G,ext} = 2.8\ \Omega, L_\sigma = 12\text{ nH}$	$T_{vj} = 25\text{ }^\circ\text{C}$	346		μJ
			$T_{vj} = 175\text{ }^\circ\text{C}$	364		
Turn-off energy at -5 V	E_{off}	$V_{DD} = 800\text{ V}, I_D = 37.4\text{ A},$ $V_{GS} = -5/18\text{ V},$ $R_{G,ext} = 2.8\ \Omega, L_\sigma = 12\text{ nH}$	$T_{vj} = 25\text{ }^\circ\text{C}$	55		μJ
			$T_{vj} = 175\text{ }^\circ\text{C}$	55		
Total switching energy at -5 V	E_{tot}	$V_{DD} = 800\text{ V}, I_D = 37.4\text{ A},$ $V_{GS} = -5/18\text{ V},$ $R_{G,ext} = 2.8\ \Omega, L_\sigma = 12\text{ nH}$	$T_{vj} = 25\text{ }^\circ\text{C}$	401		μJ
			$T_{vj} = 175\text{ }^\circ\text{C}$	419		
Virtual junction temperature	T_{vj}		-40		175	$^\circ\text{C}$

Note: Characteristics at $T_{vj} = 25\text{ }^\circ\text{C}$, unless otherwise specified.
Dynamic test circuit see Figure F, 2nd device SiC Schottky diode IDWD40G120C5.

3 Reverse-polarity protection diode

Table 5 Maximum rated values

Parameter	Symbol	Note or test condition	Values	Unit	
Diode forward current, limited by T_{vjmax}	I_F	limited by bondwire	$T_c = 25\text{ }^\circ\text{C}$	106	A
			$T_c = 100\text{ }^\circ\text{C}$	81	

(table continues...)

Table 5 (continued) Maximum rated values

Parameter	Symbol	Note or test condition	Values	Unit
Diode pulsed current, t_p limited by T_{vjmax}	I_{Fpulse}		225	A
Power dissipation	P_{tot}	$T_c = 25\text{ °C}$	356	W
		$T_c = 100\text{ °C}$	178	

Table 6 Characteristic values

Parameter	Symbol	Note or test condition	Values			Unit
			Min.	Typ.	Max.	
Diode forward voltage	V_F	$I_F = 75\text{ A}$	$T_{vj} = 25\text{ °C}$	1.65	2.15	V
			$T_{vj} = 175\text{ °C}$	1.6		
Diode reverse recovery charge	Q_{rr}	$I_F = 37.4\text{ A}$, $V_{DD} = 800\text{ V}$, $R_{G,ext} = 2.8\text{ }\Omega$, Opposite MOSFET $V_{GS} = 0/18\text{ V}$, Q_{rr} includes also Q_C	$T_{vj} = 25\text{ °C}$	4.4		μC
			$T_{vj} = 175\text{ °C}$	11.8		
Diode peak reverse recovery current	I_{rrm}	$I_F = 37.4\text{ A}$, $V_{DD} = 800\text{ V}$, $R_{G,ext} = 2.8\text{ }\Omega$, Opposite MOSFET $V_{GS} = 0/18\text{ V}$	$T_{vj} = 25\text{ °C}$	138		A
			$T_{vj} = 175\text{ °C}$	208		
Diode reverse recovery energy	E_{rec}	$I_F = 37.4\text{ A}$, $V_{DD} = 800\text{ V}$, $R_{G,ext} = 2.8\text{ }\Omega$, Opposite MOSFET $V_{GS} = 0/18\text{ V}$, Q_{rr} includes also Q_C	$T_{vj} = 25\text{ °C}$	2.7		mJ
			$T_{vj} = 175\text{ °C}$	7.4		
Virtual junction temperature	T_{vj}		-40		175	$^{\circ}\text{C}$

Note: Dynamic test circuit see Figure G, 2nd device: reverse-polarity protection co-packed diode, $V_{GS} = 0\text{ V}$.

4 Characteristics diagrams

Safe operating area (SOA)

$$I_D = f(V_{DS})$$

$$T_{vj} \leq 175^\circ\text{C}, T_c = 25^\circ\text{C}$$

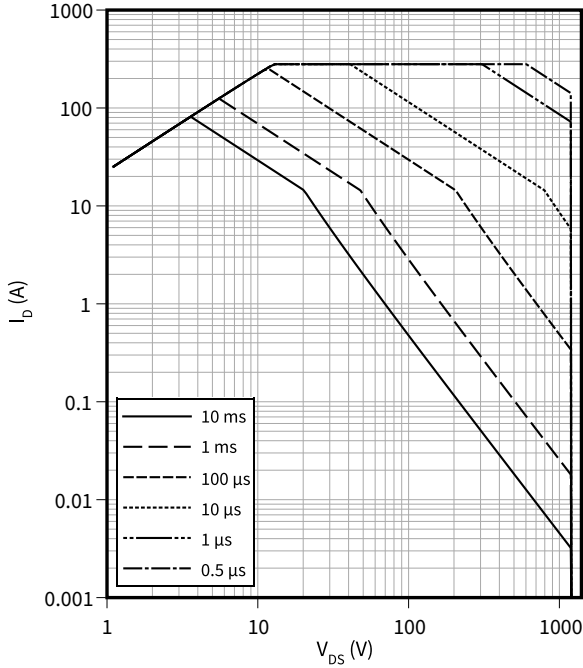

Power dissipation as a function of case temperature limited by bond wire

$$P_{tot} = f(T_c)$$

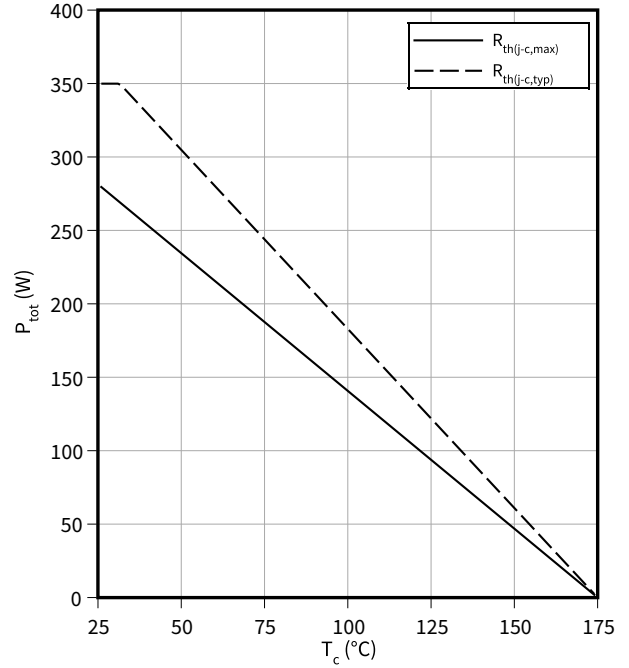

Maximum DC drain to source current as a function of case temperature limited by bond wire

$$I_D = f(T_c)$$

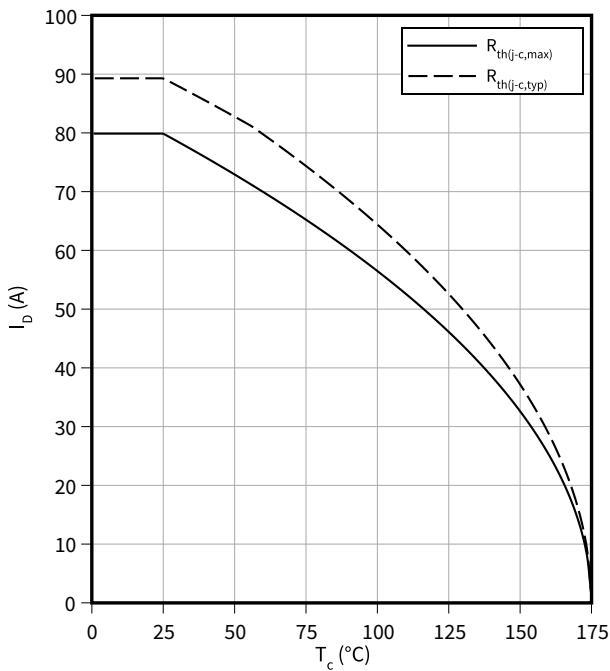

Typical transfer characteristic

$$I_D = f(V_{GS})$$

$$t_p = 20 \mu\text{s}, V_{DS} = 20 \text{ V}$$

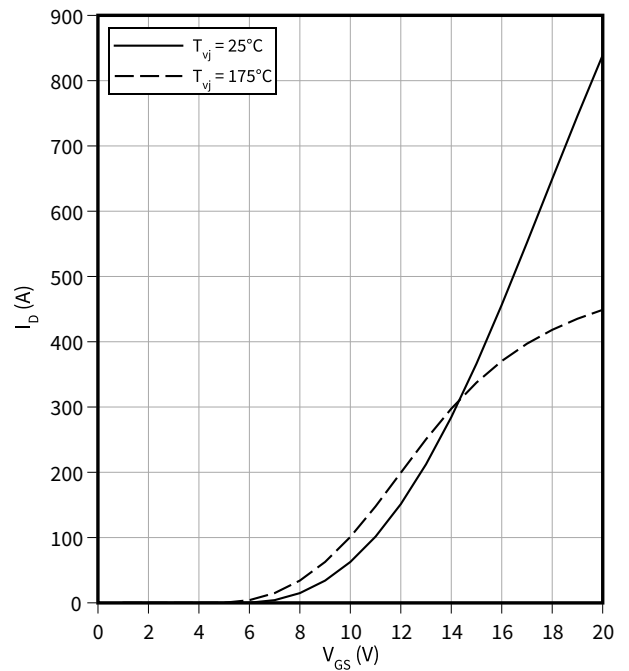

4 Characteristics diagrams

Typical gate-source threshold voltage as a function of junction temperature

$V_{GS(th)} = f(T_{vj})$
 $I_D = 11.8 \text{ mA}$

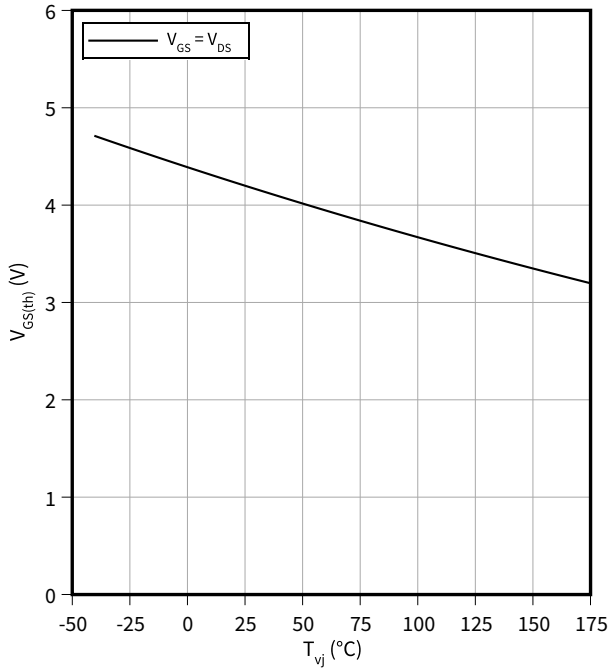

Typical output characteristic, V_{GS} as a parameter

$I_D = f(V_{DS})$
 $T_{vj} = 25 \text{ °C}, t_p = 20 \text{ } \mu\text{s}$

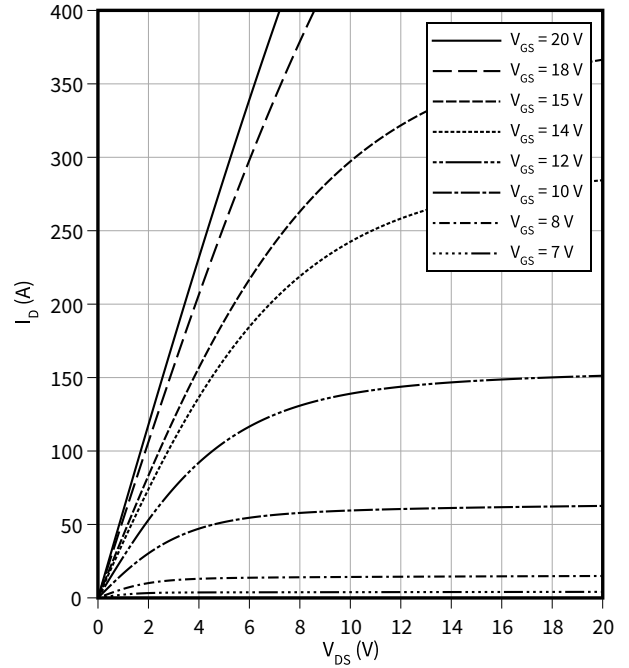

Typical output characteristic, V_{GS} as a parameter

$I_D = f(V_{DS})$
 $T_{vj} = 175 \text{ °C}, t_p = 20 \text{ } \mu\text{s}$

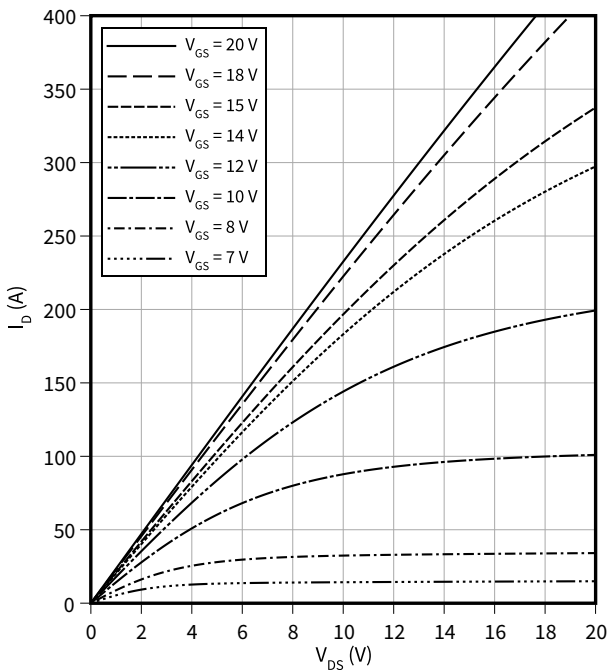

Typical on-state resistance as a function of junction temperature

$R_{DS(on)} = f(T_{vj})$
 $I_D = 37.4 \text{ A}$

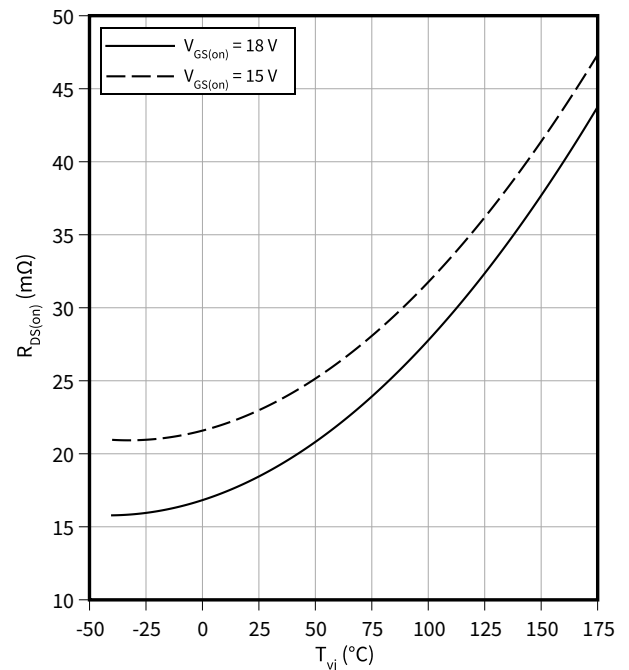

4 Characteristics diagrams

Typical gate charge

$V_{GS} = f(Q_G)$

$I_D = 37.4 \text{ A}$, $V_{DS} = 800 \text{ V}$

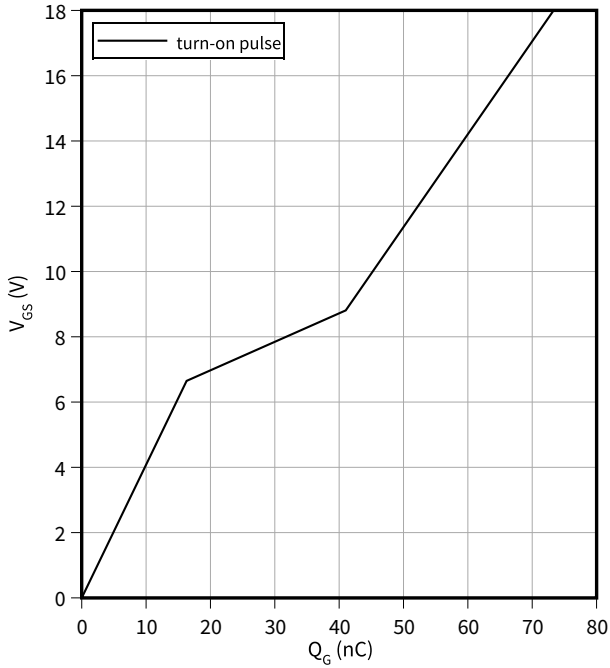

Typical capacitance as a function of drain-source voltage

$C = f(V_{DS})$

$f = 100 \text{ kHz}$, $V_{GS} = 0 \text{ V}$

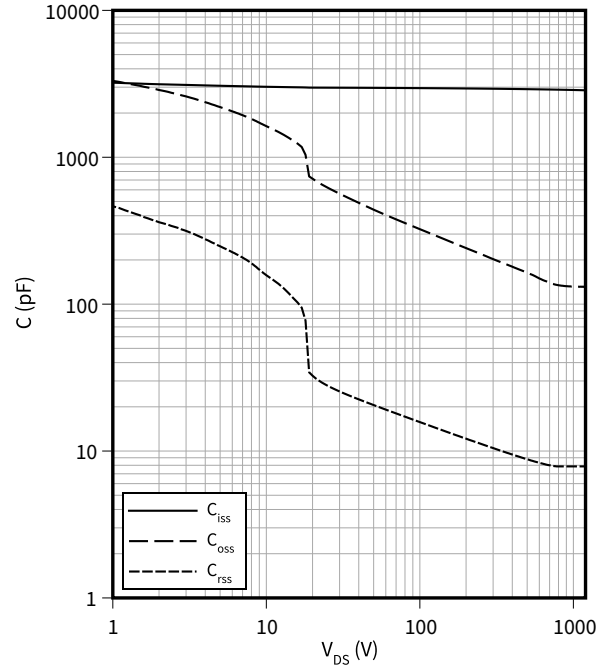

Typical switching energy as a function of junction temperature, test circuit in Fig. F, 2nd device external SiC diode

$E = f(T_{vj})$

$V_{GS} = 0/18 \text{ V}$, $I_D = 37.4 \text{ A}$, $R_{G,ext} = 2.8 \Omega$, $V_{DD} = 800 \text{ V}$

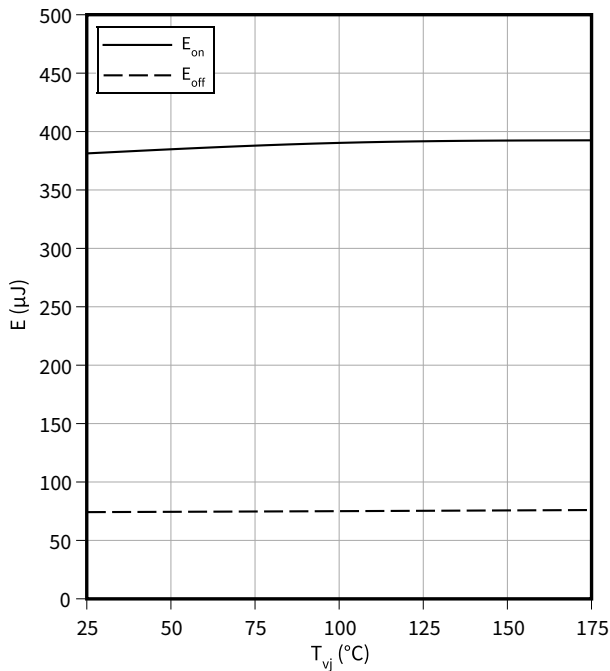

Typical switching energy as a function of junction temperature, test circuit in Fig. F, 2nd device external SiC diode

$E = f(T_{vj})$

$V_{GS} = -5/18 \text{ V}$, $I_D = 37.4 \text{ A}$, $R_{G,ext} = 2.8 \Omega$, $V_{DD} = 800 \text{ V}$

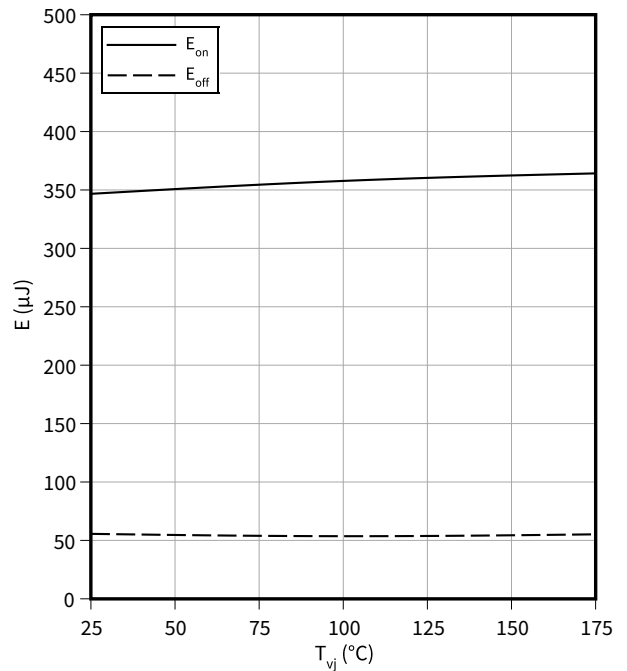

4 Characteristics diagrams

Typical switching energy as a function of drain current, test circuit in Fig. F, 2nd device external SiC diode

$E = f(I_D)$

$V_{GS} = 0/18\text{ V}$, $T_{vj} = 175\text{ °C}$, $R_{G,ext} = 2.8\ \Omega$, $V_{DD} = 800\text{ V}$

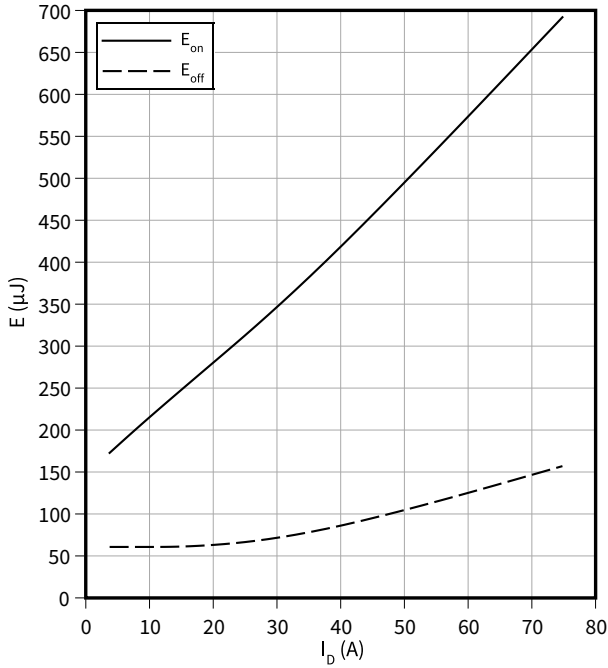

Typical switching energy as a function of drain current, test circuit in Fig. F, 2nd device external SiC diode

$E = f(I_D)$

$V_{GS} = -5/18\text{ V}$, $T_{vj} = 175\text{ °C}$, $R_{G,ext} = 2.8\ \Omega$, $V_{DD} = 800\text{ V}$

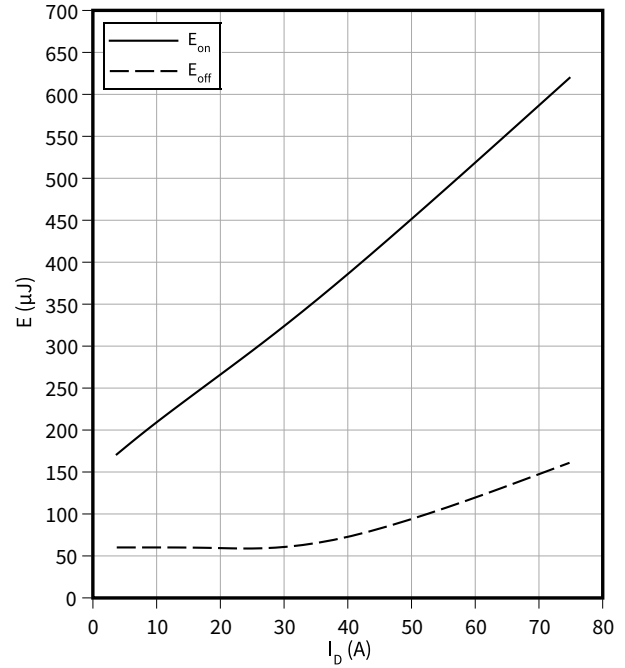

Typical switching energy as a function of gate resistance, test circuit in Fig. F, 2nd device external SiC diode

$E = f(R_{G,ext})$

$V_{GS} = 0/18\text{ V}$, $I_D = 37.4\text{ A}$, $T_{vj} = 175\text{ °C}$, $V_{DD} = 800\text{ V}$

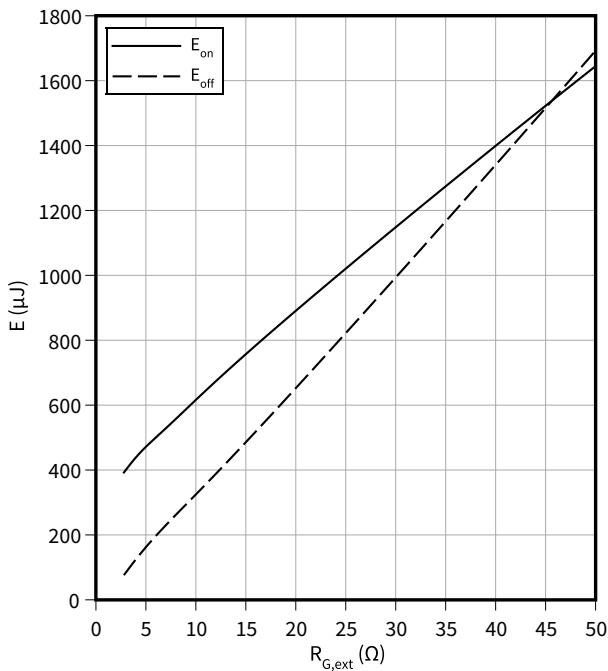

Typical switching energy as a function of gate resistance, test circuit in Fig. F, 2nd device external SiC diode

$E = f(R_{G,ext})$

$V_{GS} = -5/18\text{ V}$, $I_D = 37.4\text{ A}$, $T_{vj} = 175\text{ °C}$, $V_{DD} = 800\text{ V}$

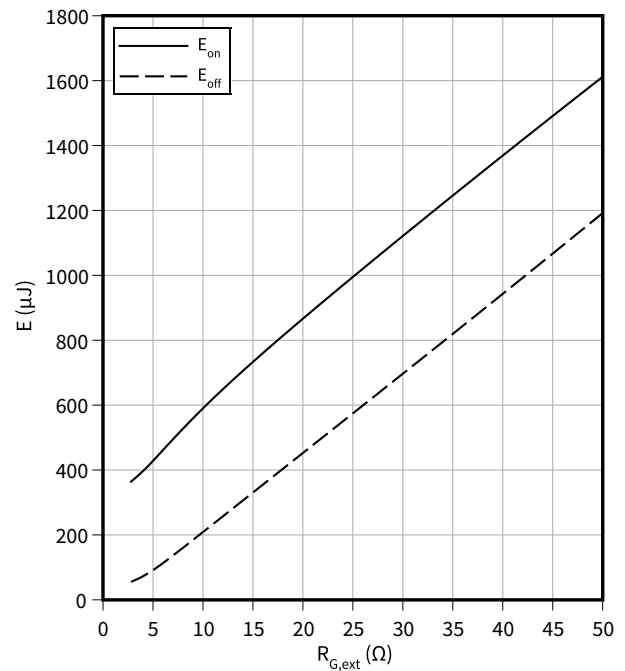

4 Characteristics diagrams

Typical switching energy as a function of DC link voltage, test circuit in Fig. F, 2nd device external SiC diode

$E = f(V_{DD})$
 $V_{GS} = 0/18\text{ V}$, $I_D = 37.4\text{ A}$, $T_{vj} = 175\text{ °C}$, $R_{G,ext} = 2.8\text{ }\Omega$

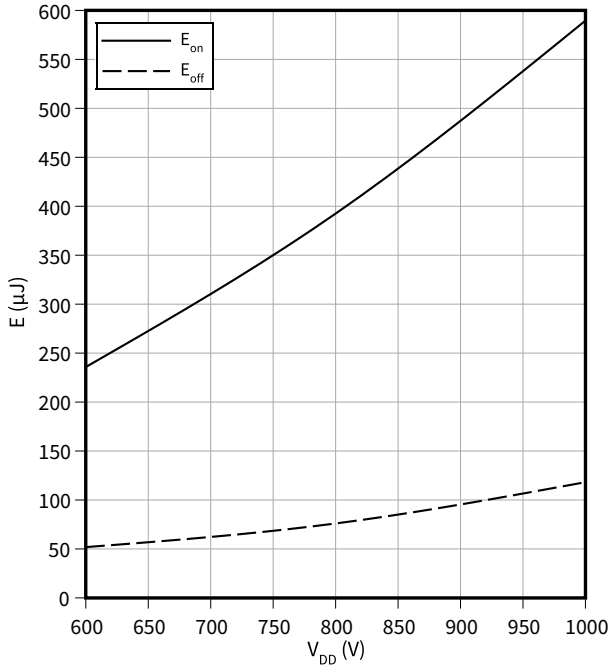

Typical switching energy as a function of DC link voltage, test circuit in Fig. F, 2nd device external SiC diode

$E = f(V_{DD})$
 $V_{GS} = -5/18\text{ V}$, $I_D = 37.4\text{ A}$, $T_{vj} = 175\text{ °C}$, $R_{G,ext} = 2.8\text{ }\Omega$

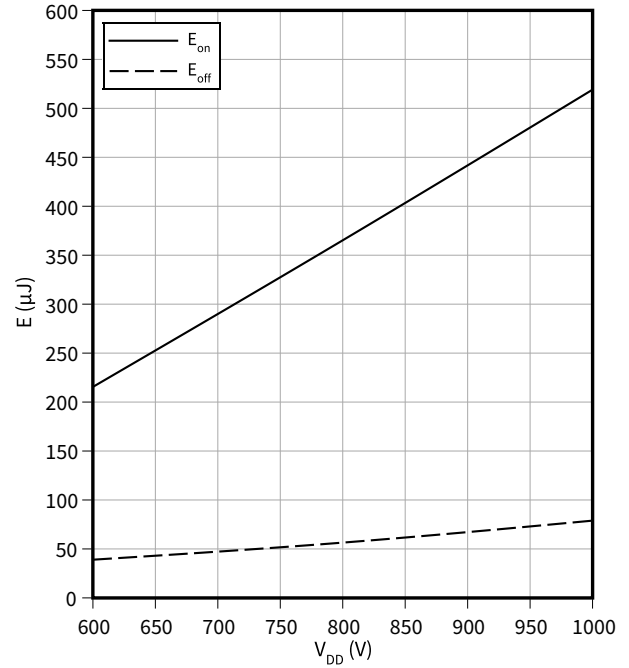

Typical switching times as a function of gate resistance, test circuit in Fig. F, 2nd device external SiC diode

$t = f(R_{G,ext})$
 $V_{GS} = 0/18\text{ V}$, $I_D = 37.4\text{ A}$, $T_{vj} = 175\text{ °C}$, $V_{DD} = 800\text{ V}$

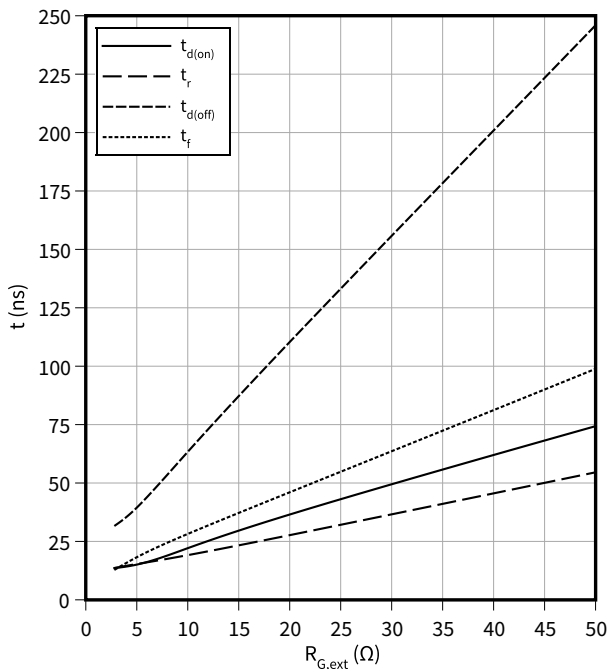

Max. transient thermal impedance (MOSFET)

$Z_{th(j-c),max} = f(t_p)$
 $D = t_p/T$

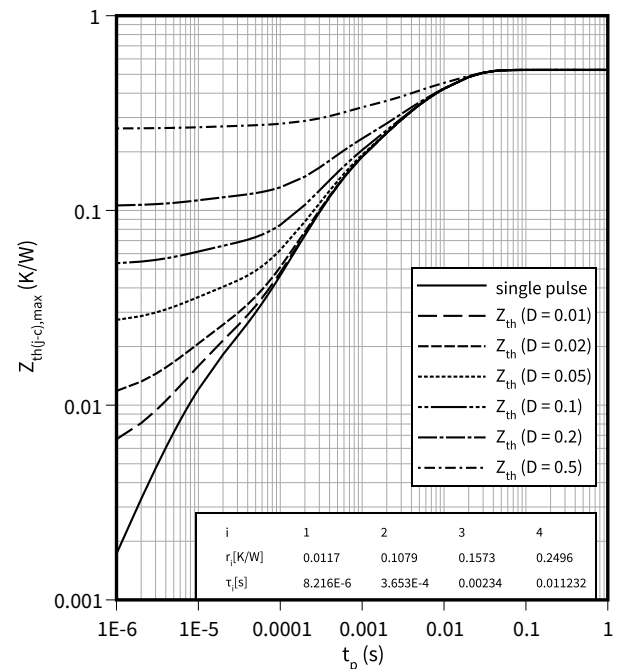

4 Characteristics diagrams

Typical diode forward current as a function of forward voltage, V_{GS} as a parameter

$I_F = f(V_F)$
 $t_p = 20 \mu s, T_{vj} = 25 \text{ }^\circ\text{C}$

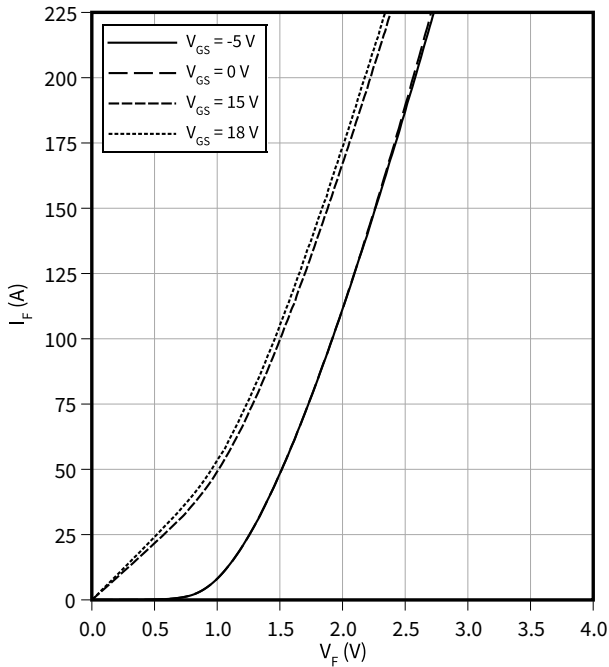

Typical diode forward current as a function of forward voltage, V_{GS} as a parameter

$I_F = f(V_F)$
 $t_p = 20 \mu s, T_{vj} = 175 \text{ }^\circ\text{C}$

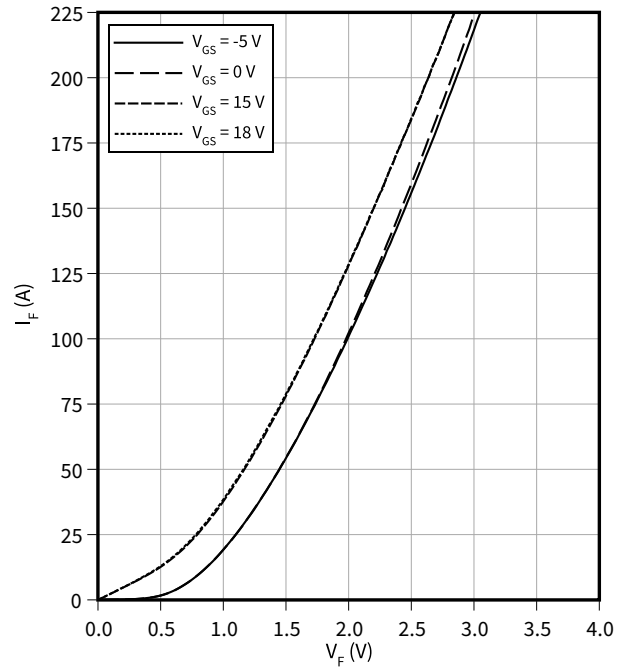

Maximum diode forward current as a function of case temperature limited by bond wire

$I_F = f(T_c)$
 $V_{GS} = 0 \text{ V}$

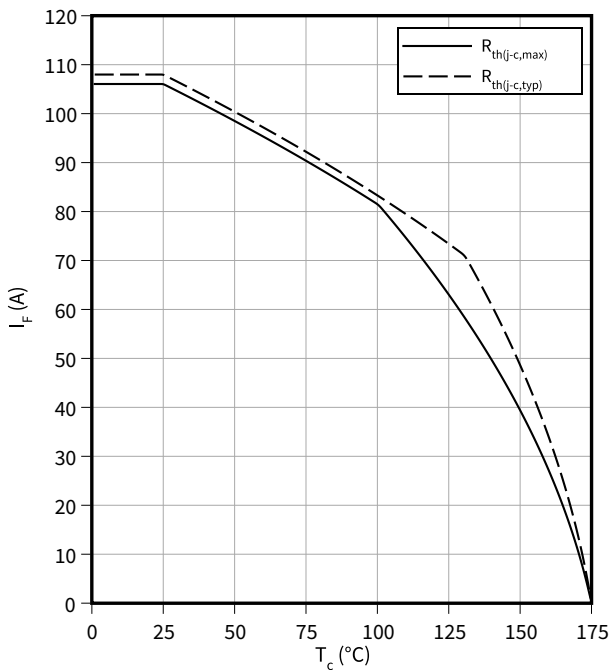

Typical diode forward voltage as function of junction temperature

$V_F = f(T_{vj})$
 $V_{GS} = 0 \text{ V}$

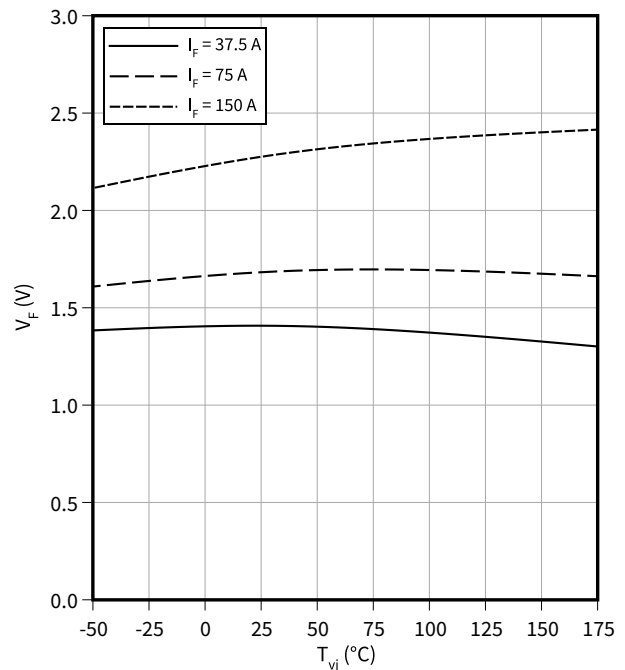

4 Characteristics diagrams

Typical reverse recovery charge as function of diode current slope, test circuit in Fig. G, 2nd device reverse-polarity protection co-packed diode

$$Q_{rr} = f(-di_F/dt)$$

$V_{GS} = 0/18\text{ V}$, $V_{DD} = 800\text{ V}$, $I_F = 37.4\text{ A}$

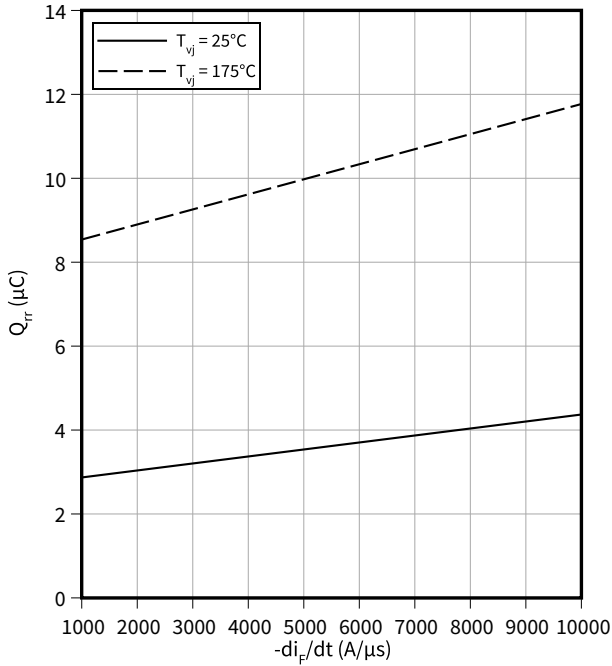

Typical reverse recovery current as function of diode current slope, test circuit in Fig. G, 2nd device reverse-polarity protection co-packed diode

$$I_{rrm} = f(-di_F/dt)$$

$V_{GS} = 0/18\text{ V}$, $V_{DD} = 800\text{ V}$, $I_F = 37.4\text{ A}$

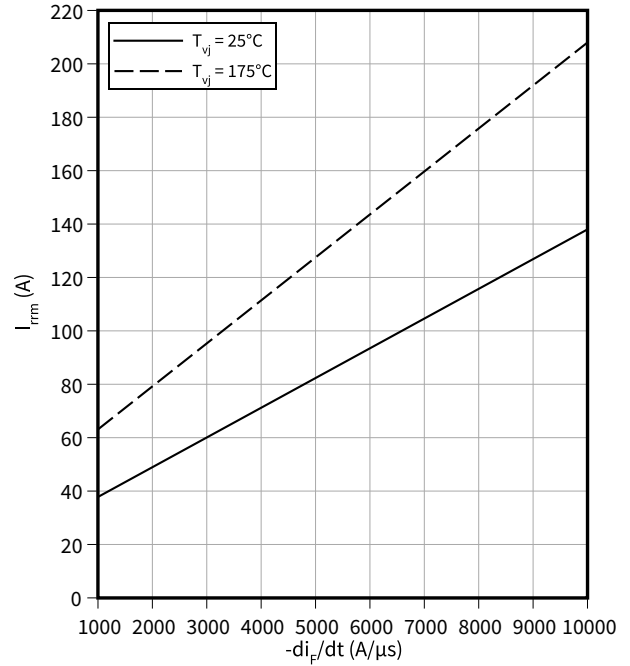

Typical reverse energy losses as function of junction temperature, test circuit in Fig. G, 2nd device reverse-polarity protection co-packed diode

$$E_{rec} = f(T_{vj})$$

$V_{GS} = 0/18\text{ V}$, $R_{G,ext} = 2.8\ \Omega$, $V_{DD} = 800\text{ V}$, $I_F = 37.4\text{ A}$

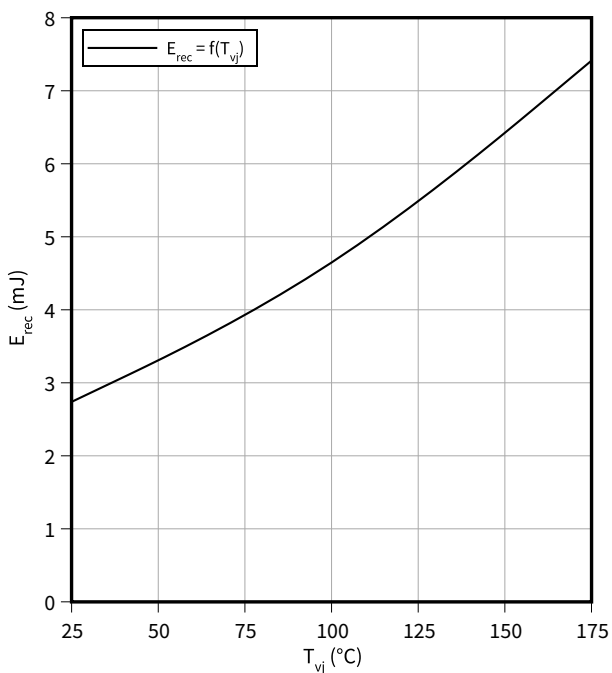

Typical reverse energy losses as function of diode current, test circuit in Fig. G, 2nd device reverse-polarity protection co-packed diode

$$E_{rec} = f(I_F)$$

$V_{GS} = 0/18\text{ V}$, $T_{vj} = 175\text{ °C}$, $R_{G,ext} = 2.8\ \Omega$, $V_{DD} = 800\text{ V}$

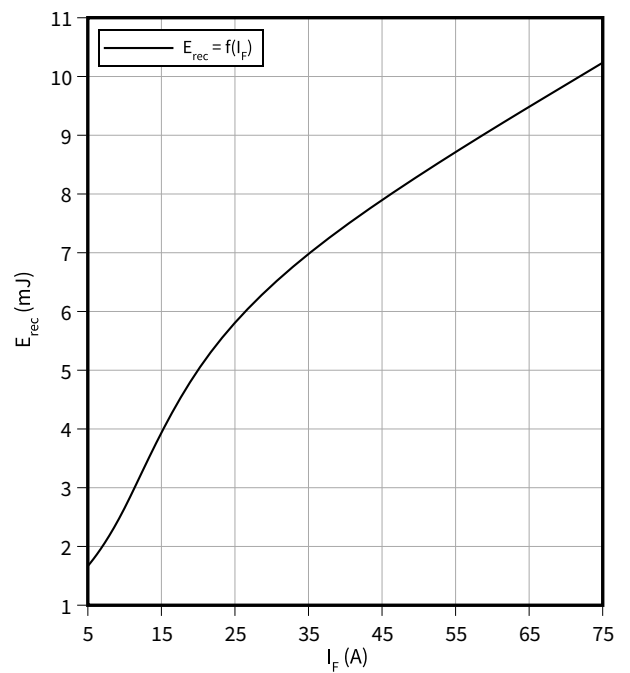

4 Characteristics diagrams

Max. transient thermal impedance (protection diode)

$$Z_{th(j-c),max} = f(t_p)$$

$$D = t_p/T$$

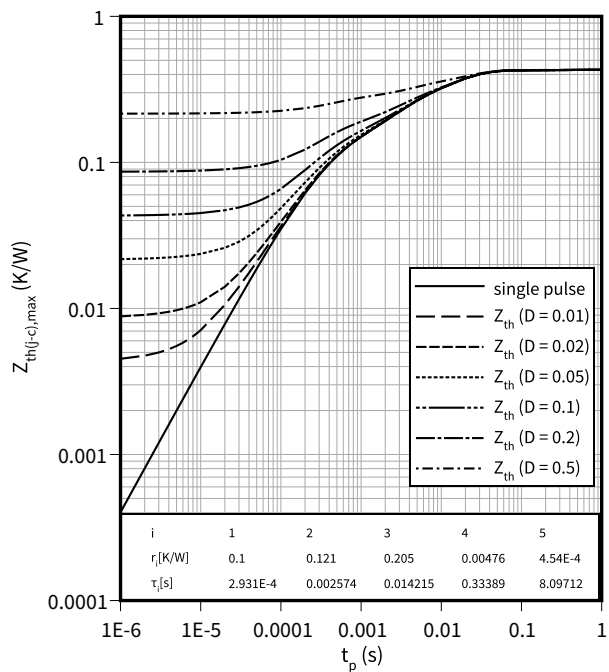

5 Package outlines

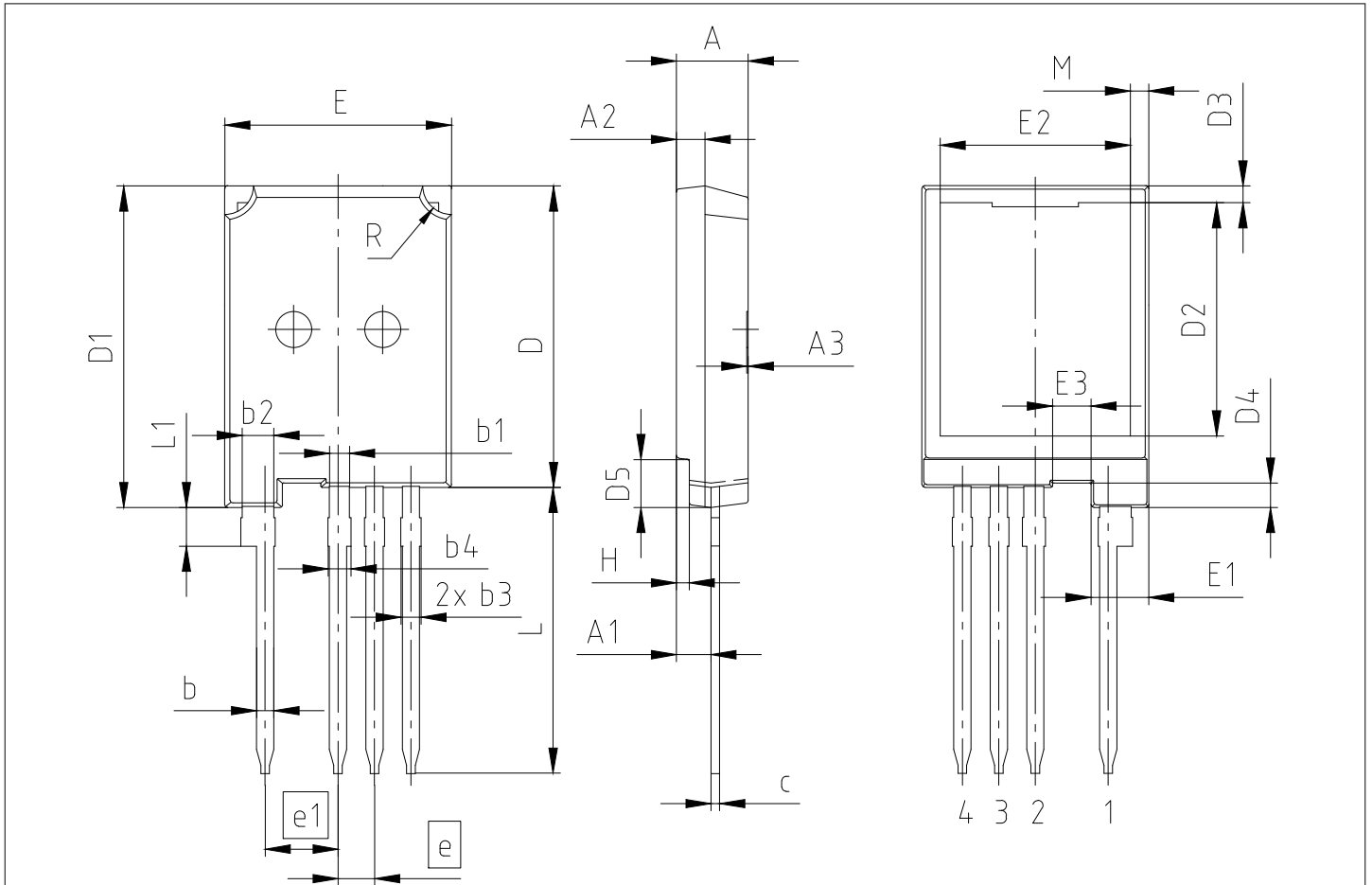

NOTES:
PACKAGE SURFACE ROUTE BETWEEN PIN 1 & PIN 2 WILL BE 5.1 mm MIN.
ALL b... AND c DIMENSIONS INCLUDING PLATING EXPECT AREA OF CUTTING

PACKAGE - GROUP NUMBER:		PG-TO247-4-U10			
DIMENSIONS	MILLIMETERS		DIMENSIONS	MILLIMETERS	
	MIN.	MAX.		MIN.	MAX.
A	4.90	5.10	E	15.70	15.90
A1	2.31	2.51	E1	3.90	4.10
A2	1.90	2.10	E2	13.10	13.50
b	1.16	1.29	E3	2.58	2.78
b1	1.36	1.49	e	2.54	
b2	2.16	2.29	e1	5.08	
b3	1.16	1.45	H	0.80	1.00
b4	1.16	1.65	N	4	
c	0.59	0.66	L	19.80	20.10
D	20.90	21.10	L1	2.55	2.85
D1	22.30	22.50	M	0.97	1.57
D2	15.95	16.55	R	1.90	2.10
D3	1.00	1.35			
D4	1.60	1.80			
D5	3.24	3.44			

Figure 1

6 Testing conditions

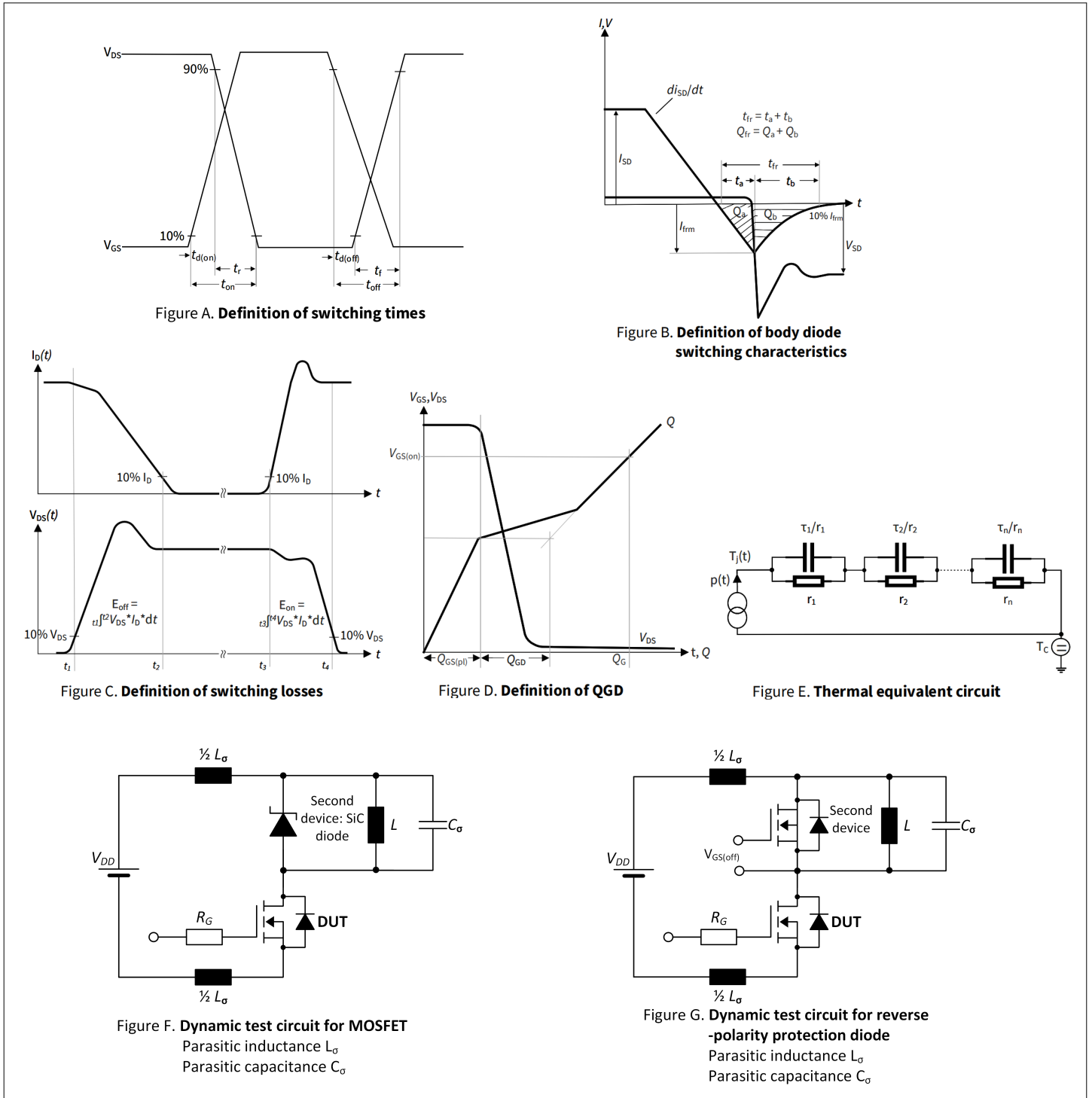

Figure 2

Revision history

Document revision	Date of release	Description of changes
0.10	2025-03-12	Target datasheet
0.20	2025-08-08	Preliminary datasheet
1.00	2025-11-20	Final datasheet

Trademarks

All referenced product or service names and trademarks are the property of their respective owners.

Edition 2025-11-20

Published by

Infineon Technologies AG

81726 Munich, Germany

© 2025 Infineon Technologies AG

All Rights Reserved.

Do you have a question about any aspect of this document?

Email: erratum@infineon.com

Document reference

IFX-ABN225-003

Important notice

The information given in this document shall in no event be regarded as a guarantee of conditions or characteristics ("Beschaffheitsgarantie").

With respect to any examples, hints or any typical values stated herein and/or any information regarding the application of the product, Infineon Technologies hereby disclaims any and all warranties and liabilities of any kind, including without limitation warranties of non-infringement of intellectual property rights of any third party.

In addition, any information given in this document is subject to customer's compliance with its obligations stated in this document and any applicable legal requirements, norms and standards concerning customer's products and any use of the product of Infineon Technologies in customer's applications.

The data contained in this document is exclusively intended for technically trained staff. It is the responsibility of customer's technical departments to evaluate the suitability of the product for the intended application and the completeness of the product information given in this document with respect to such application.

Please note that this product is not qualified according to the AEC Q100 or AEC Q101 documents of the Automotive Electronics Council.

Warnings

Due to technical requirements products may contain dangerous substances. For information on the types in question please contact your nearest Infineon Technologies office.

Except as otherwise explicitly approved by Infineon Technologies in a written document signed by authorized representatives of Infineon Technologies, Infineon Technologies' products may not be used in any applications where a failure of the product or any consequences of the use thereof can reasonably be expected to result in personal injury.