

## Final datasheet

### EasyPACK™ 模块 采用 CoolSiC™ Trench MOSFET 带有 PressFIT 压接管脚和温度检测 NTC

#### 特性

- 电气特性
  - $V_{DSS} = 1200\text{ V}$
  - $I_{DN} = 25\text{ A} / I_{DRM} = 50\text{ A}$
  - 低电感设计
  - 低开关损耗
  - 可以从下面链接寻找适合的英飞凌驱动 IC <https://www.infineon.com/gdfinder>
- 机械特性
  - PressFIT 压接技术
  - 高电流压接管脚
  - 集成 NTC 温度传感器

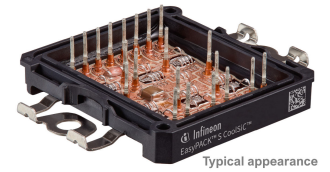

#### 可选应用

- 高频开关应用
- DC/DC 变换器
- 有源整流器
- 车载蓄电池充电机 - 混合动力/纯电动汽车

#### 产品认证

- Qualified according to AQC 324, release no.: 03.1/2021

#### 描述

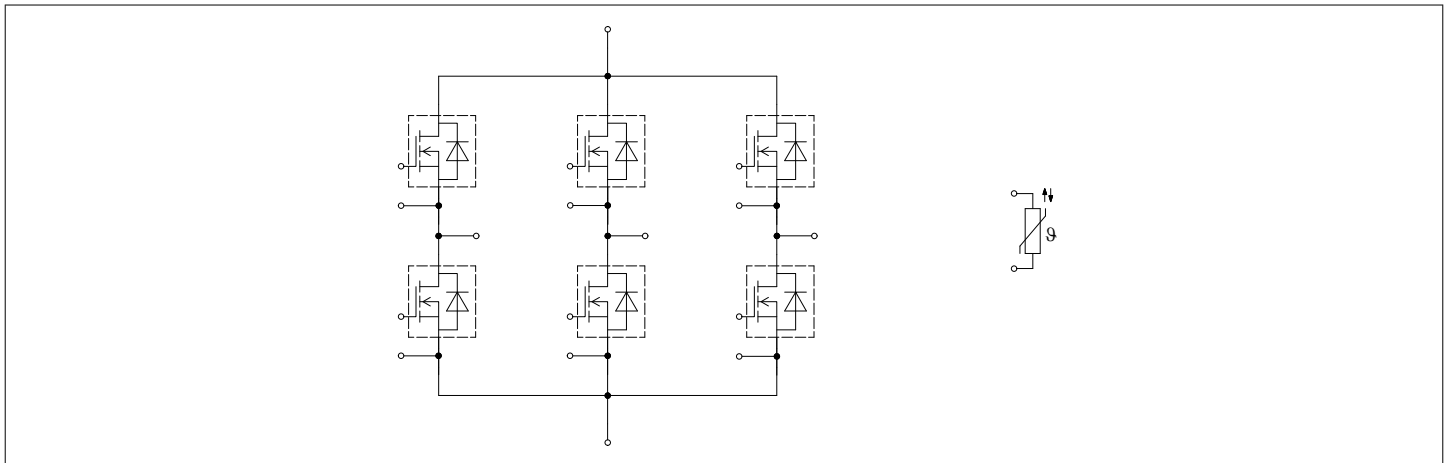

## 内容

	描述.....	1
	特性.....	1
	可选应用.....	1
	产品认证.....	1
	内容.....	2
1	封装.....	3
2	<b>MOSFET</b> .....	3
3	<b>Body diode (MOSFET)</b> .....	5
4	负温度系数热敏电阻.....	6
5	特征参数图表.....	7
6	电路拓扑图.....	13
7	封装尺寸.....	14
8	模块标签代码.....	15
	修订历史.....	16
	免责声明.....	17

## 1 封装

## 1 封装

表 1 绝缘参数

特征参数	代号	标注或测试条件	数值	单位
绝缘测试电压	$V_{ISOL}$	RMS, $f = 50 \text{ Hz}$ , $t = 1 \text{ min}$	4.0	kV
NTC 绝缘测试电压	$V_{ISOL(NTC)}$	RMS, $f = 50 \text{ Hz}$ , $t = 1 \text{ min}$	1.0	kV
内部绝缘			$Al_2O_3$	
相对电痕指数	$CTI$		600	
相对温度指数 (电)	$RTI$	封装	200	°C

表 2 特征值

特征参数	代号	标注或测试条件	数值			单位
			最小值	典型值	最大值	
杂散电感, 模块	$L_{SDS}$			10		nH
模块引线电阻, 端子-芯片	$R_{DD'+SS'}$	$T_H = 25 \text{ °C}$ , 每个开关		2.8		mΩ
储存温度	$T_{stg}$		-40		125	°C
Mounting force per clamp	$F$		20		30	N
重量	$G$			10		g

注：单引脚到50A 的电流耐受值受限于引脚与PCB 设计及其散热条件之间的相互作用

## 2 MOSFET

表 3 最大标定值

特征参数	代号	标注或测试条件		数值	单位
漏源极电压	$V_{DSS}$		$T_{vj} = 25 \text{ °C}$	1200	V
植入漏极电流	$I_{DN}$			25	A
连续漏极直流电流	$I_{DDC}$	$T_{vj} = 175 \text{ °C}$ , $V_{GS} = 18 \text{ V}$	$T_H = 85 \text{ °C}$	25	A
漏极重复峰值电流	$I_{DRM}$	verified by design, $t_p$ limited by $T_{vjmax}$		50	A
栅-源瞬态最大电压	$V_{GS}$	$D < 0.01$		-10/25	V
栅-源稳态最大电压	$V_{GS}$			-7/20	V

表 4 推荐值

特征参数	代号	标注或测试条件	[ZH]Values	单位
通态栅极电压	$V_{GS(on)}$		15...18	V
断态栅极电压	$V_{GS(off)}$		-5...0	V

表 5 特征值

特征参数	代号	标注或测试条件		数值			单位
				最小值	典型值	最大值	
漏源通态电阻	$R_{DS(on)}$	$I_D = 25\text{ A}$	$V_{GS} = 15\text{ V}, T_{vj} = 25\text{ °C}$		26.2		mΩ
					22.9	38.5	
					38.8		
					52		
栅极阈值电压	$V_{GS(th)}$	$V_{DS} = V_{GS}, (\text{tested after 1ms pulse at } V_{GS} = +20\text{ V}), T_{vj} = 25\text{ °C}, I_D = 10.4\text{ mA}$		3.45	4.2	5.15	V
		$V_{DS} = V_{GS}, (\text{tested after 1ms pulse at } V_{GS} = +20\text{ V}), T_{vj} = 175\text{ °C}, I_D = 10.4\text{ mA}$			3.2		
栅极电荷	$Q_G$	$V_{DD} = 800\text{ V}, V_{GS} = -3/18\text{ V}, T_{vj} = 25\text{ °C}$			0.076		μC
内部栅极电阻	$R_{Gint}$	$T_{vj} = 25\text{ °C}$			1.5		Ω
输入电容	$C_{ISS}$	$f = 100\text{ kHz}, V_{DS} = 800\text{ V}, V_{GS} = 0\text{ V}$	$T_{vj} = 25\text{ °C}$		2.6		nF
输出电容	$C_{OSS}$	$f = 100\text{ kHz}, V_{DS} = 800\text{ V}, V_{GS} = 0\text{ V}$	$T_{vj} = 25\text{ °C}$		0.1		nF
反向传输电容	$C_{RSS}$	$f = 100\text{ kHz}, V_{DS} = 800\text{ V}, V_{GS} = 0\text{ V}$	$T_{vj} = 25\text{ °C}$		6.48		pF
$C_{OSS}$ 存储能量	$E_{OSS}$	$V_{DS} = 800\text{ V}, V_{GS} = -3/18\text{ V}, T_{vj} = 25\text{ °C}$			40.9		μJ
漏源泄漏电流	$I_{DSS}$	$V_{DS} = 1200\text{ V}, V_{GS} = -3\text{ V}$	$T_{vj} = 25\text{ °C}$			111	μA
栅极漏电流	$I_{GSS}$	$V_{DS} = 0\text{ V}, T_{vj} = 25\text{ °C}$	$V_{GS} = 20\text{ V}$			400	nA
开通延迟时间(感性负载)	$t_{d\ on}$	$I_D = 25\text{ A}, R_{Gon} = 8\text{ Ω}, V_{DD} = 800\text{ V}, V_{GS} = -3/18\text{ V}, t_{dead} = 1000\text{ ns}, 0.1\text{ }V_{GS}\text{ to }0.1\text{ }I_D$	$T_{vj} = 25\text{ °C}$		23.1		ns
			$T_{vj} = 125\text{ °C}$		23.7		
			$T_{vj} = 175\text{ °C}$		24		
上升时间(感性负载)	$t_r$	$I_D = 25\text{ A}, R_{Gon} = 8\text{ Ω}, V_{DD} = 800\text{ V}, V_{GS} = -3/18\text{ V}, t_{dead} = 1000\text{ ns}, 0.1\text{ }I_D\text{ to }0.9\text{ }I_D$	$T_{vj} = 25\text{ °C}$		5.4		ns
			$T_{vj} = 125\text{ °C}$		4.9		
			$T_{vj} = 175\text{ °C}$		4.8		
关断延迟时间(感性负载)	$t_{d\ off}$	$I_D = 25\text{ A}, R_{Goff} = 0.51\text{ Ω}, V_{DD} = 800\text{ V}, V_{GS} = -3/18\text{ V}, 0.9\text{ }V_{GS}\text{ to }0.9\text{ }I_D$	$T_{vj} = 25\text{ °C}$		13.9		ns
			$T_{vj} = 125\text{ °C}$		14.9		
			$T_{vj} = 175\text{ °C}$		15.4		

(待续)

表 5 (续) 特征值

特征参数	代号	标注或测试条件	数值			单位
			最小值	典型值	最大值	
下降时间(感性负载)	$t_f$	$I_D = 25\text{ A}$ , $R_{Goff} = 0.51\ \Omega$ , $V_{DD} = 800\text{ V}$ , $V_{GS} = -3/18\text{ V}$ , $0.9 I_D$ to $0.1 I_D$	$T_{vj} = 25\text{ }^\circ\text{C}$	18		ns
			$T_{vj} = 125\text{ }^\circ\text{C}$	18.1		
			$T_{vj} = 175\text{ }^\circ\text{C}$	18.2		
开通损耗能量(每脉冲)	$E_{on}$	$I_D = 25\text{ A}$ , $V_{DD} = 800\text{ V}$ , $L_\sigma = 15\text{ nH}$ , $V_{GS} = -3/18\text{ V}$ , $R_{Gon} = 8\ \Omega$ , $di/dt = 6.2$ $\text{kA}/\mu\text{s}$ ( $T_{vj} = 175\text{ }^\circ\text{C}$ ), $t_{dead} = 1000\text{ ns}$	$T_{vj} = 25\text{ }^\circ\text{C}$	482		$\mu\text{J}$
			$T_{vj} = 125\text{ }^\circ\text{C}$	567		
			$T_{vj} = 175\text{ }^\circ\text{C}$	670		
开通损耗能量(每脉冲), 优化条件下	$E_{on,o}$	$I_D = 25\text{ A}$ , $V_{DD} = 800\text{ V}$ , $L_\sigma = 15\text{ nH}$ , $V_{GS} = -3/18\text{ V}$ , $R_{Gon,o} = 6.8\ \Omega$ , $di/dt = 7.3$ $\text{kA}/\mu\text{s}$ ( $T_{vj} = 175\text{ }^\circ\text{C}$ ), $t_{dead} = 100\text{ ns}$	$T_{vj} = 25\text{ }^\circ\text{C}$	405		$\mu\text{J}$
			$T_{vj} = 125\text{ }^\circ\text{C}$	437		
			$T_{vj} = 175\text{ }^\circ\text{C}$	483		
关断损耗能量(每脉冲)	$E_{off}$	$I_D = 25\text{ A}$ , $V_{DD} = 800\text{ V}$ , $L_\sigma = 15\text{ nH}$ , $V_{GS} = -3/18\text{ V}$ , $R_{Goff} = 0.51\ \Omega$ , $dv/dt = 60$ $\text{kV}/\mu\text{s}$ ( $T_{vj} = 175\text{ }^\circ\text{C}$ )	$T_{vj} = 25\text{ }^\circ\text{C}$	81		$\mu\text{J}$
			$T_{vj} = 125\text{ }^\circ\text{C}$	82		
			$T_{vj} = 175\text{ }^\circ\text{C}$	82		
结-散热器热阻	$R_{thJH}$	每个 MOSFET, $\lambda_{grease} = 5\text{ W}/(\text{m}\cdot\text{K})$		1.63		K/W
允许开关的温度范围	$T_{vjop}$		-40		175	$^\circ\text{C}$

**注:** The selection of positive and negative gate-source voltages impacts losses and the long-term behavior of the MOSFET and body diode. The design guidelines described in Application Notes AN 2018-09 and AN 2025-02 must be considered to ensure sound operation of the device over the planned lifetime.

### 3 Body diode (MOSFET)

表 6 最大标定值

特征参数	代号	标注或测试条件	数值	单位
体二极管正向直流电流	$I_{SD}$	$T_{vj} = 175\text{ }^\circ\text{C}$ , $V_{GS} = -3\text{ V}$ $T_H = 65\text{ }^\circ\text{C}$	16	A
Pulsed body diode current	$I_{SD\ pulse}$		50	A

表 7 特征值

特征参数	代号	标注或测试条件	数值			单位
			最小值	典型值	最大值	
正向电压	$V_{SD}$	$I_{SD} = 25 \text{ A}, V_{GS} = -3 \text{ V}$	$T_{vj} = 25 \text{ }^\circ\text{C}$	4.25	5.15	V
			$T_{vj} = 125 \text{ }^\circ\text{C}$	3.95		
			$T_{vj} = 175 \text{ }^\circ\text{C}$	3.8		
反向恢复峰值电流	$I_{rrm}$	$I_{SD} = 25 \text{ A}, di_s/dt = 6.2 \text{ kA}/\mu\text{s}, V_{DD} = 800 \text{ V}, V_{GS} = 18/-3 \text{ V}, t_{dead} = 1000 \text{ ns}$	$T_{vj} = 25 \text{ }^\circ\text{C}$	43		A
			$T_{vj} = 125 \text{ }^\circ\text{C}$	47		
			$T_{vj} = 175 \text{ }^\circ\text{C}$	53		
恢复电荷	$Q_{rr}$	$I_{SD} = 25 \text{ A}, di_s/dt = 6.2 \text{ kA}/\mu\text{s}, V_{DD} = 800 \text{ V}, V_{GS} = 18/-3 \text{ V}, t_{dead} = 1000 \text{ ns}$	$T_{vj} = 25 \text{ }^\circ\text{C}$	38		$\mu\text{C}$
			$T_{vj} = 125 \text{ }^\circ\text{C}$	53		
			$T_{vj} = 175 \text{ }^\circ\text{C}$	68		
反向恢复损耗（每脉冲）	$E_{rec}$	$I_{SD} = 25 \text{ A}, di_s/dt = 6.2 \text{ kA}/\mu\text{s} (T_{vj} = 175 \text{ }^\circ\text{C}), V_{DD} = 800 \text{ V}, V_{GS} = 18/-3 \text{ V}, t_{dead} = 1000 \text{ ns}$	$T_{vj} = 25 \text{ }^\circ\text{C}$	104		$\mu\text{J}$
			$T_{vj} = 125 \text{ }^\circ\text{C}$	138		
			$T_{vj} = 175 \text{ }^\circ\text{C}$	169		
反向恢复损耗（每脉冲），优化条件下	$E_{rec,o}$	$I_{SD} = 25 \text{ A}, di_s/dt = 7.3 \text{ kA}/\mu\text{s} (T_{vj} = 175 \text{ }^\circ\text{C}), V_{DD} = 800 \text{ V}, t_{dead} = 100 \text{ ns}$	$T_{vj} = 25 \text{ }^\circ\text{C}$	94		$\mu\text{J}$
			$T_{vj} = 125 \text{ }^\circ\text{C}$	97		
			$T_{vj} = 175 \text{ }^\circ\text{C}$	113		

## 4 负温度系数热敏电阻

表 8 特征值

特征参数	代号	标注或测试条件	数值			单位
			最小值	典型值	最大值	
额定电阻值	$R_{25}$	$T_{NTC} = 25 \text{ }^\circ\text{C}$		10		k $\Omega$
$R_{100}$ 偏差	$\Delta R/R$	$T_{NTC} = 100 \text{ }^\circ\text{C}, R_{100} = 977 \text{ } \Omega$	-3		3	%
耗散功率	$P_{25}$	$T_{NTC} = 25 \text{ }^\circ\text{C}$			20	mW
B-值	$B_{25/50}$	$R_2 = R_{25} \exp[B_{25/50}(1/T_2 - 1/(298,15 \text{ K}))]$		3450		K
B-值	$B_{25/80}$	$R_2 = R_{25} \exp[B_{25/80}(1/T_2 - 1/(298,15 \text{ K}))]$		3490		K
B-值	$B_{25/100}$	$R_2 = R_{25} \exp[B_{25/100}(1/T_2 - 1/(298,15 \text{ K}))]$		3510		K

注：NTC 的具体参数分析请见 AN2009-10, 第 4 章

5 特征参数图表

输出特性 (典型), MOSFET

$I_D = f(V_{DS})$

$V_{GS} = 18\text{ V}$

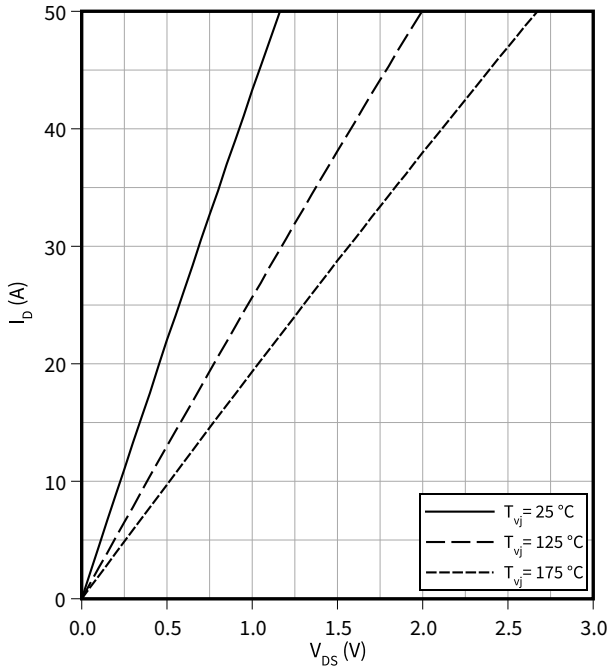

输出特性 (典型), MOSFET

$I_D = f(V_{DS})$

$V_{GS} = 15\text{ V}$

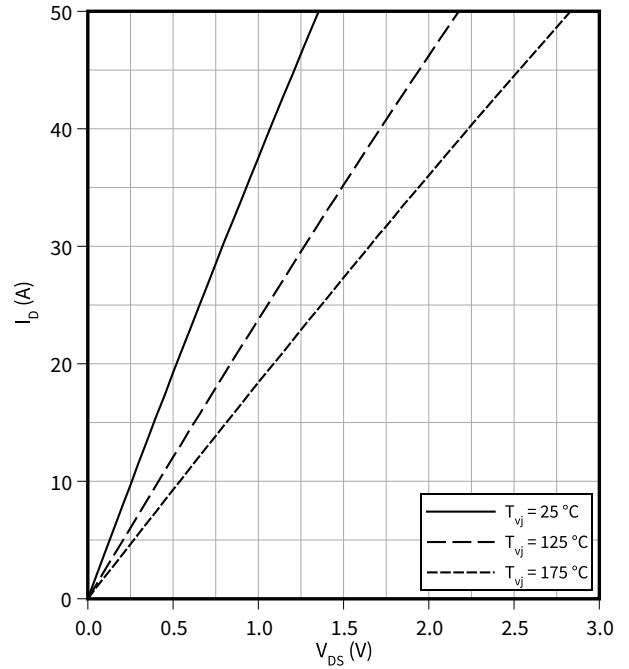

输出特性 (典型), MOSFET

$I_D = f(V_{DS})$

$T_{vj} = 175\text{ °C}$

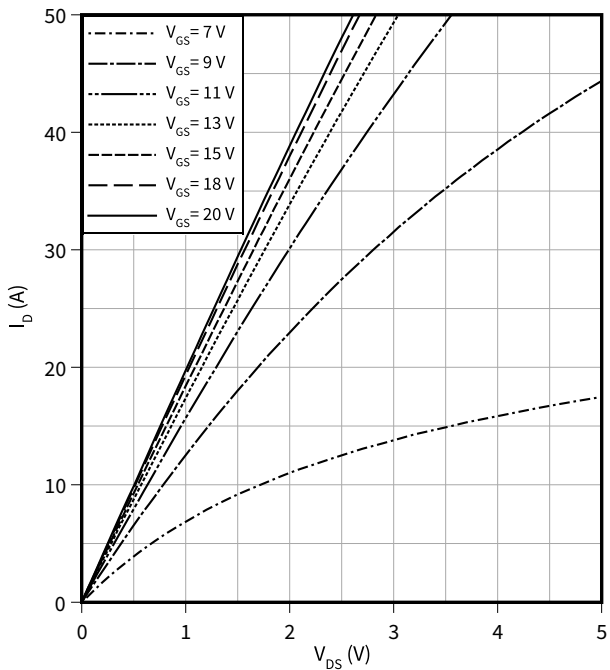

漏源通态电阻 (典型), MOSFET

$R_{DS(on)} = f(T_{vj})$

$I_D = 25\text{ A}$

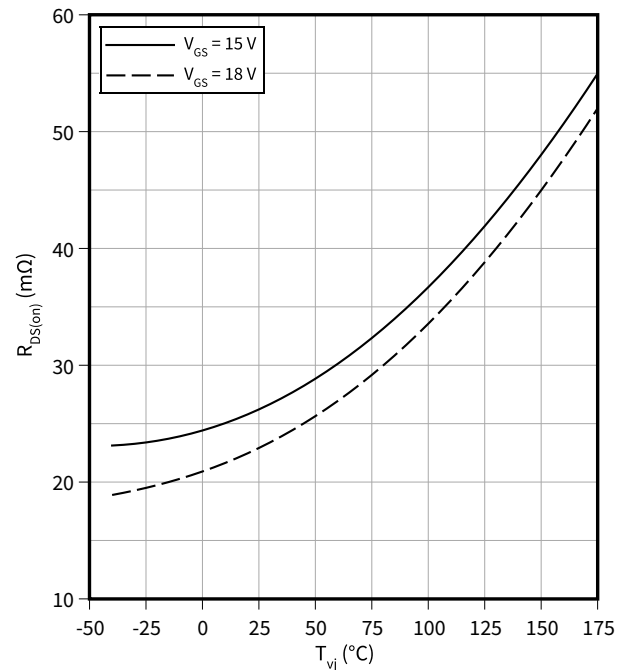

传输特性 (典型), MOSFET

$I_D = f(V_{GS})$   
 $V_{DS} = 20\text{ V}$

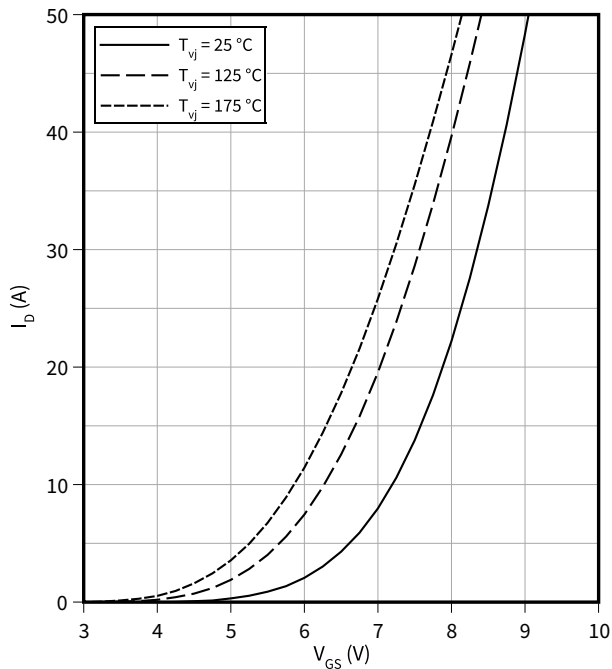

栅-源阈值电压 (典型), MOSFET

$V_{GS(th)} = f(T_{vj})$   
 $V_{GS} = V_{DS}$

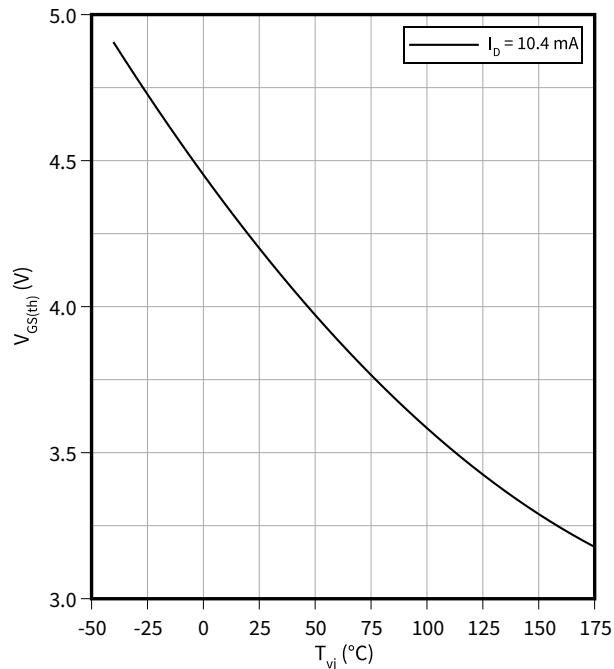

栅极电荷特性 (典型), MOSFET

$V_{GS} = f(Q_G)$   
 $I_D = 25\text{ A}, T_{vj} = 25^\circ\text{C}$

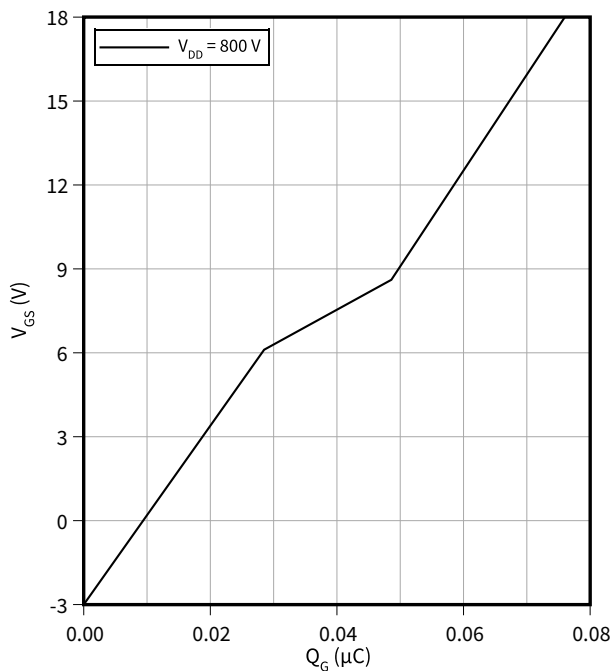

电容特性 (典型), MOSFET

$C = f(V_{DS})$   
 $f = 100\text{ kHz}, T_{vj} = 25^\circ\text{C}, V_{GS} = 0\text{ V}$

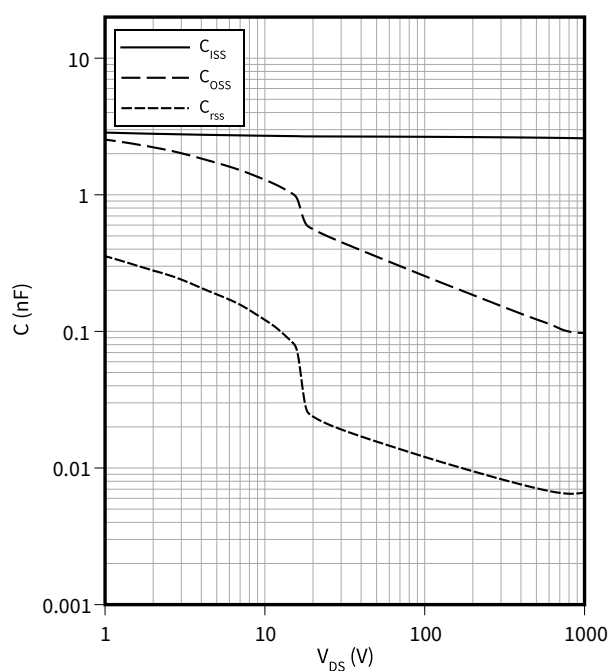

开关时间 (典型), MOSFET

$t = f(I_D)$

$V_{DD} = 800\text{ V}$ ,  $R_{Gon} = 8\ \Omega$ ,  $R_{Gon,o} = 6.8\ \Omega$ ,  $T_{vj} = 175\ ^\circ\text{C}$ ,  $V_{GS} = -3/18\text{ V}$

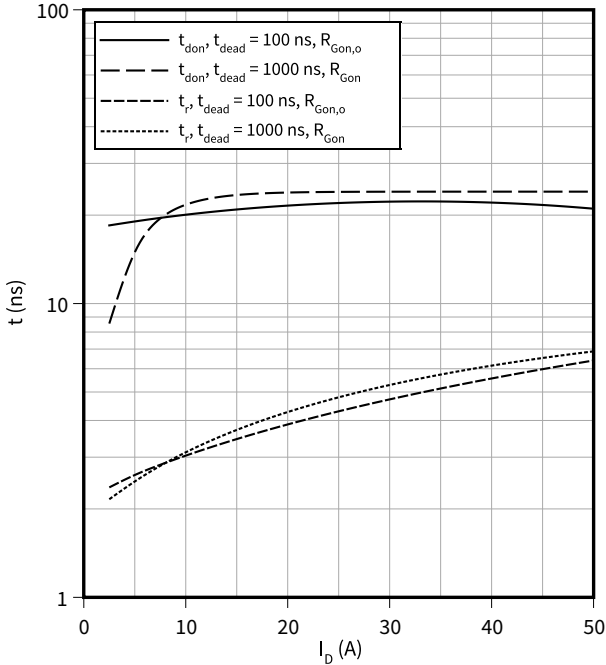

开关时间 (典型), MOSFET

$t = f(I_D)$

$R_{Goff} = 0.51\ \Omega$ ,  $V_{DD} = 800\text{ V}$ ,  $T_{vj} = 175\ ^\circ\text{C}$ ,  $V_{GS} = -3/18\text{ V}$

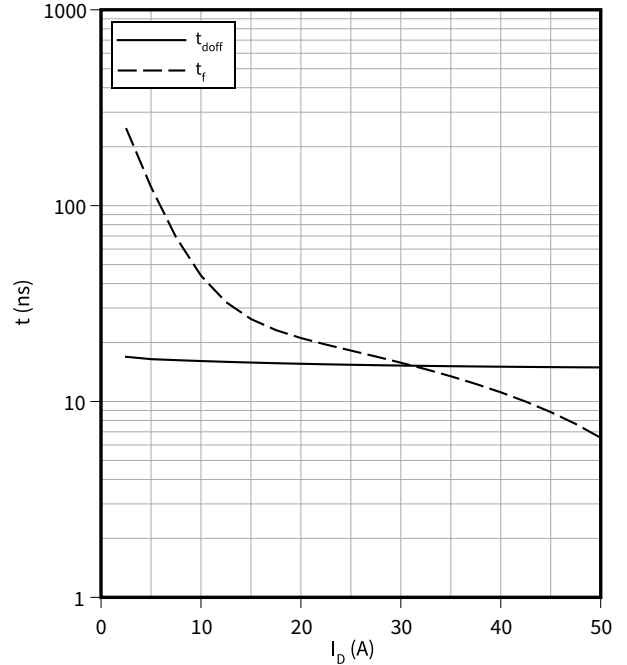

开关时间 (典型), MOSFET

$t = f(R_G)$

$T_{vj} = 175\ ^\circ\text{C}$ ,  $V_{GS} = -3/18\text{ V}$ ,  $V_{DD} = 800\text{ V}$ ,  $t_{dead} = 1000\text{ ns}$ ,  $I_D = 25\text{ A}$

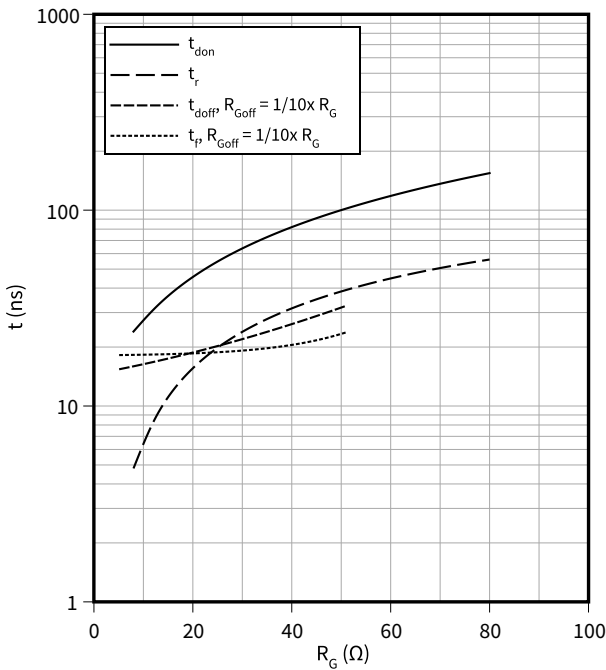

电流变化斜率 (典型), MOSFET

$di/dt_{on} = f(R_{Gon})$

$V_{DD} = 800\text{ V}$ ,  $t_{dead} = 1000\text{ ns}$ ,  $I_D = 25\text{ A}$ ,  $V_{GS} = -3/18\text{ V}$

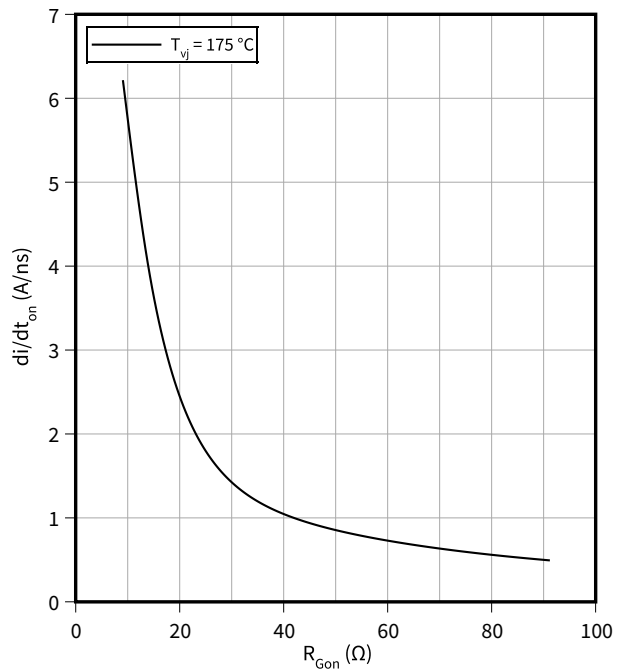

电压变化斜率 (典型), MOSFET

$dv/dt_{off} = f(R_{Goff})$

$V_{DD} = 800\text{ V}, I_D = 25\text{ A}, V_{GS} = -3/18\text{ V}$

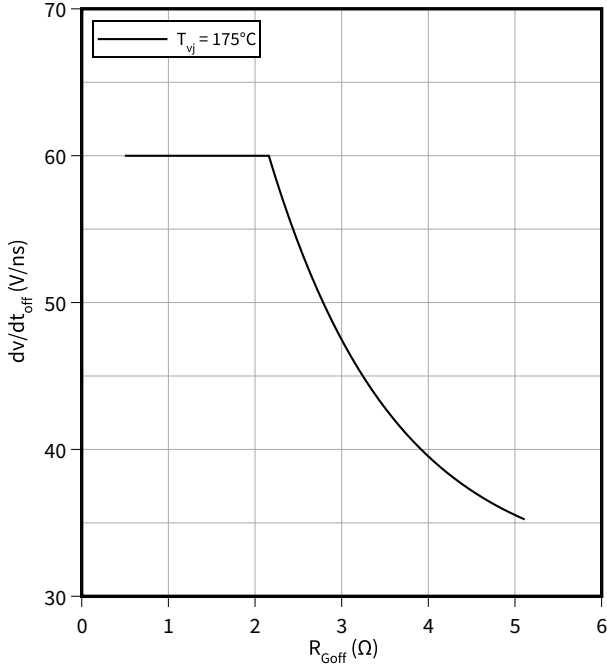

开关损耗 (典型), MOSFET

$E_{on} = f(I_D)$

$V_{DD} = 800\text{ V}, R_{Gon} = 8\ \Omega, R_{Gon,o} = 6.8\ \Omega, V_{GS} = -3/18\text{ V}$

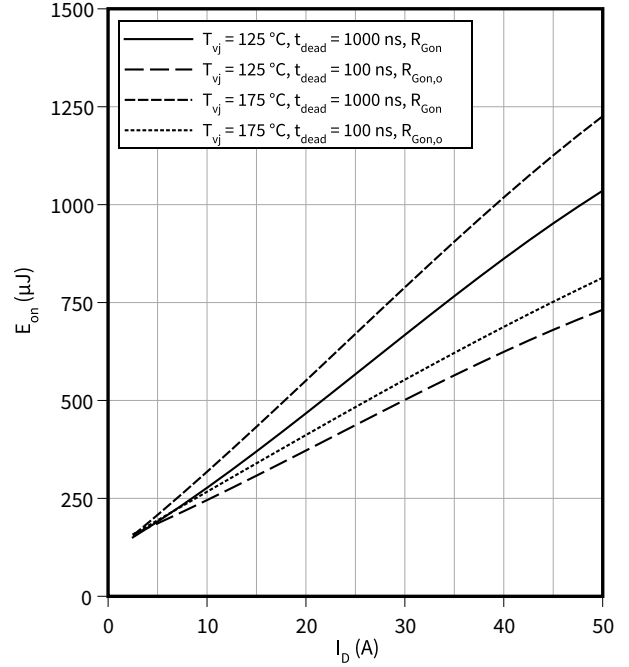

开关损耗 (典型), MOSFET

$E_{off} = f(I_D)$

$R_{Goff} = 0.51\ \Omega, V_{DD} = 800\text{ V}, V_{GS} = -3/18\text{ V}$

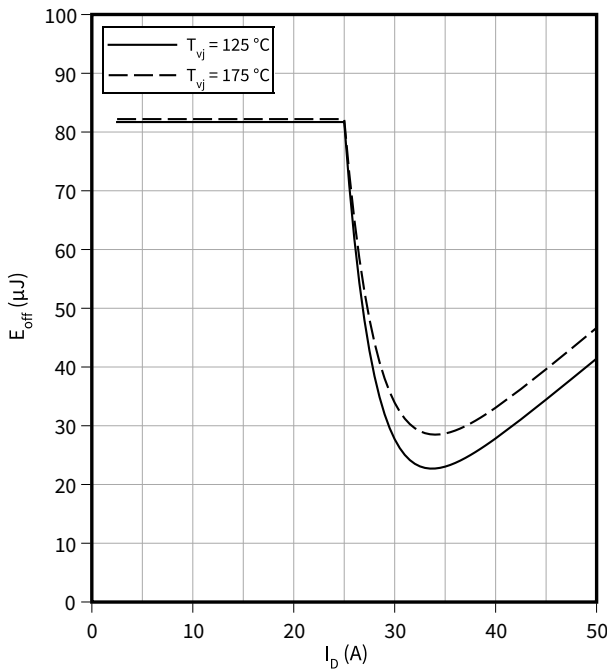

开关损耗 (典型), MOSFET

$E_{off} = f(R_G), E = f(R_G)$

$V_{DD} = 800\text{ V}, t_{dead} = 1000\text{ ns}, I_D = 25\text{ A}, V_{GS} = -3/18\text{ V}$

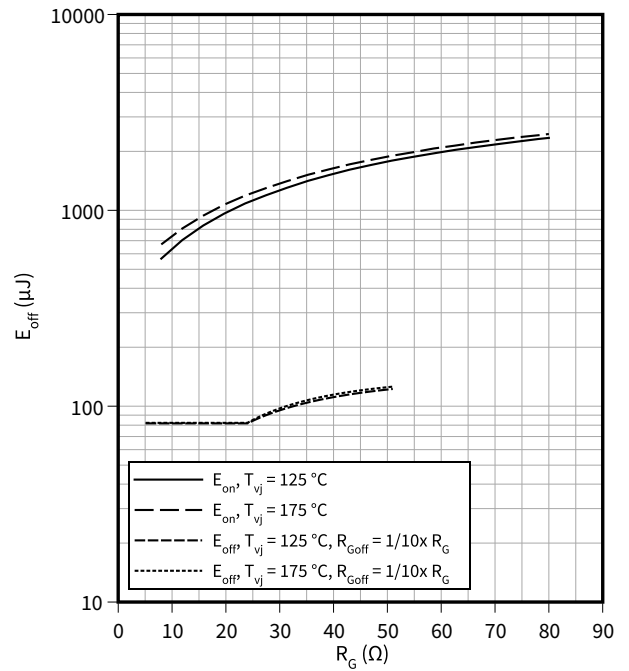

开关损耗 (典型), MOSFET

$$E_{on} = f(V_{GS(off)})$$

$R_{Goff} = 0.51 \Omega$ ,  $V_{DD} = 800 V$ ,  $R_{Gon} = 8 \Omega$ ,  $V_{GS(on)} = 18 V$ ,  
 $I_D = 25 A$ ,  $R_{Gon,o} = 6.8 \Omega$ ,  $T_{vj} = 175 \text{ }^\circ\text{C}$

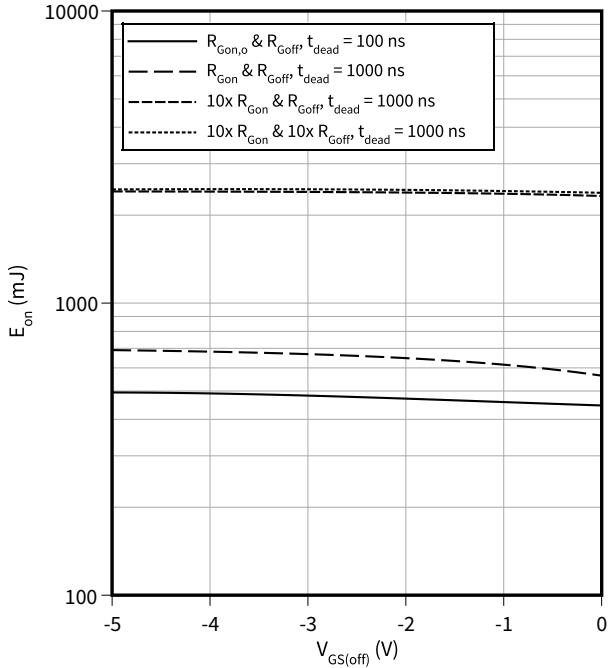

开关损耗 (典型), MOSFET

$$E_{on} = f(t_{dead})$$

$R_{Gon} = 8 \Omega$ ,  $I_D = 25 A$ ,  $V_{DD} = 800 V$ ,  $V_{GS} = -3/18 V$

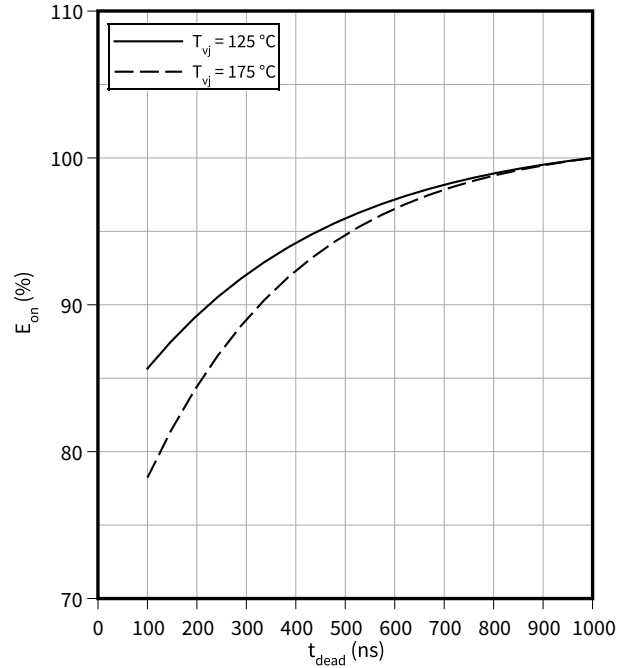

反偏安全工作区 (RBSOA), MOSFET

$$I_D = f(V_{DS})$$

$R_{Goff} = 0.51 \Omega$ ,  $T_{vj} = 175 \text{ }^\circ\text{C}$ ,  $V_{GS} = -3/18 V$

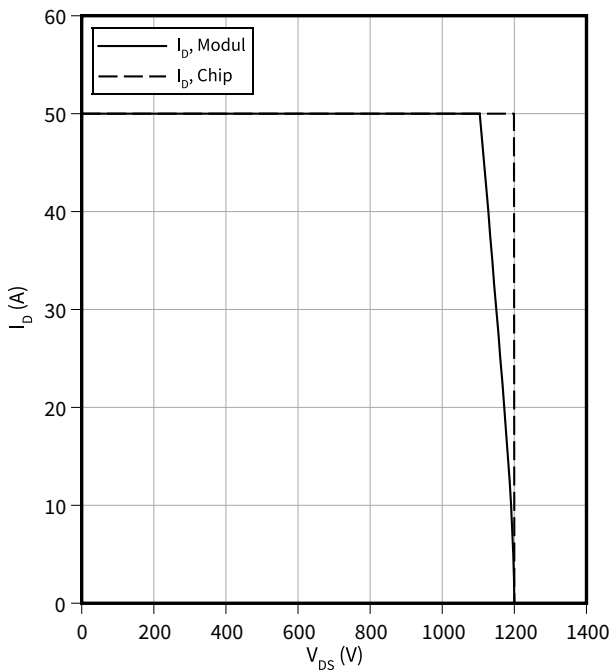

瞬态热阻抗, MOSFET

$$Z_{th} = f(t)$$

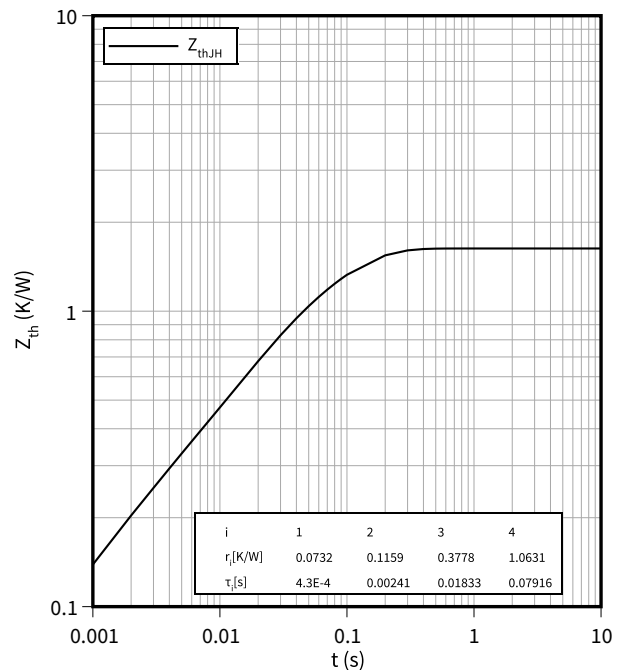

i	1	2	3	4
r <sub>i</sub> [K/W]	0.0732	0.1159	0.3778	1.0631
t <sub>i</sub> [s]	4.3E-4	0.00241	0.01833	0.07916

正向特性 体二极管 (典型), MOSFET

$I_{SD} = f(V_{SD})$

$T_{vj} = 175\text{ }^{\circ}\text{C}$

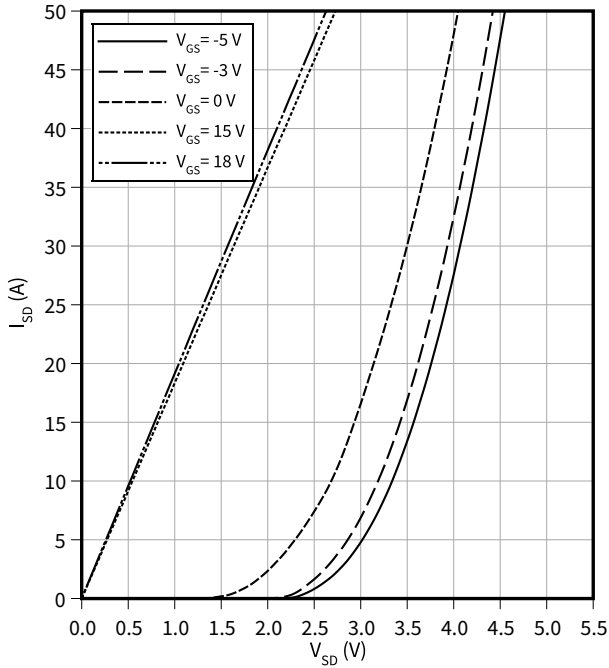

开关损耗 体二极管 (典型), MOSFET

$E_{rec} = f(V_{GS(off)})$

$R_{Goff} = 0.51\ \Omega$ ,  $R_{Gon} = 8\ \Omega$ ,  $V_{GS(on)} = 18\ \text{V}$ ,  $I_{SD} = 25\ \text{A}$ ,  
 $R_{Gon,o} = 6.8\ \Omega$ ,  $V_{DD} = 800\ \text{V}$ ,  $T_{vj} = 175\text{ }^{\circ}\text{C}$

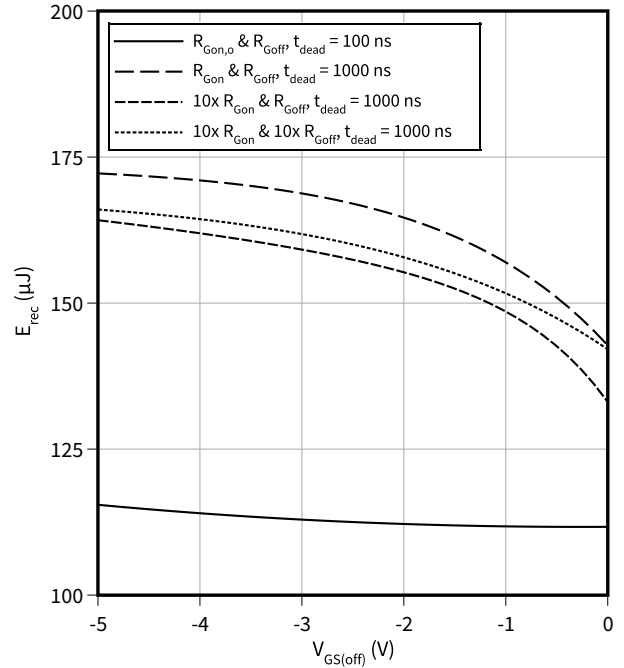

开关损耗 体二极管 (典型), MOSFET

$E_{rec} = f(t_{dead})$

$R_{Gon} = 8\ \Omega$ ,  $I_D = 25\ \text{A}$ ,  $V_{DD} = 800\ \text{V}$ ,  $V_{GS} = -3/18\ \text{V}$

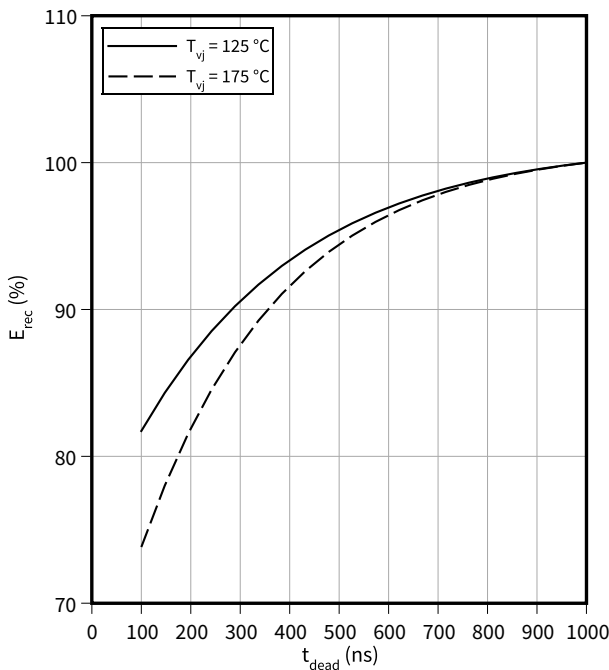

温度特性, 负温度系数热敏电阻

$R = f(T_{NTC})$

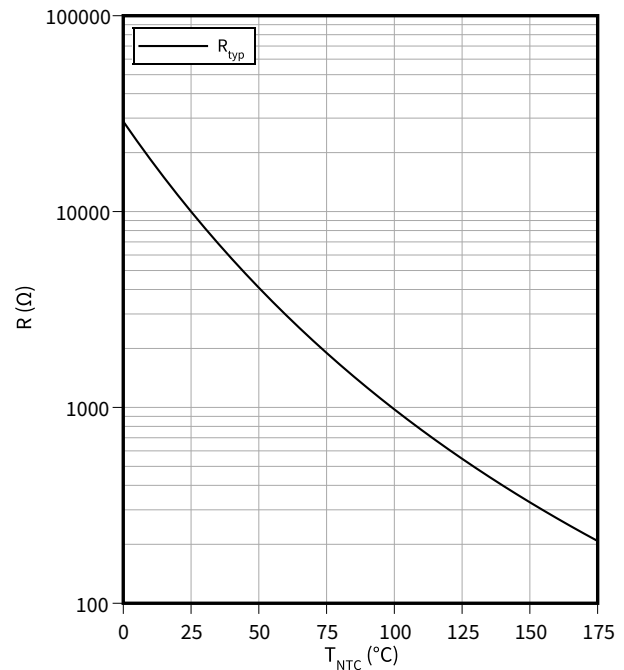

## 6 电路拓扑图



图 1

7 封装尺寸

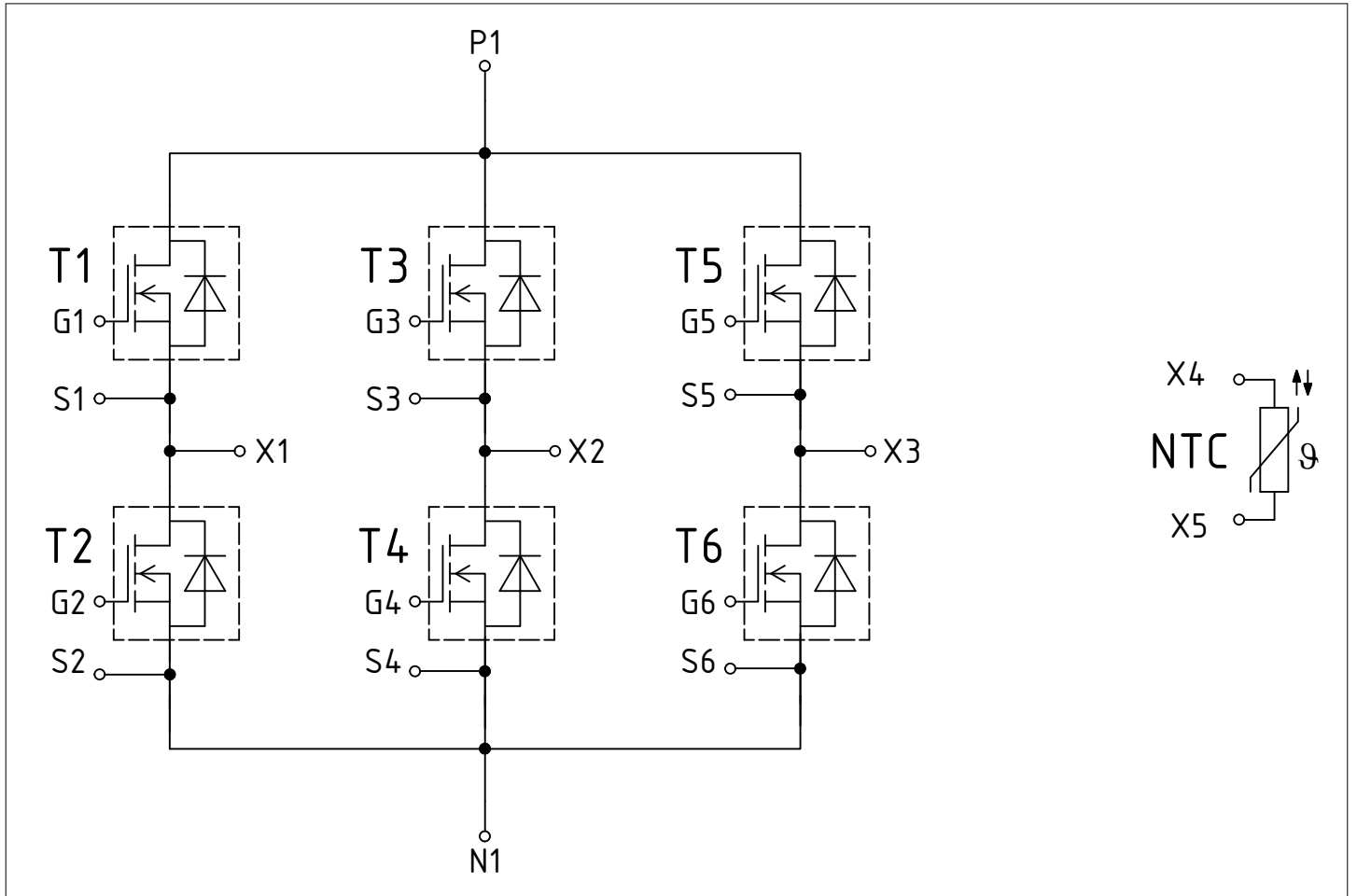

图 2

## 8 模块标签代码

Module label code			
Code format	Data Matrix	Barcode Code128	
Encoding	ASCII text	Code Set A	
Symbol size	16x16	23 digits	
Standard	IEC24720 and IEC16022	IEC8859-1	
Code content	Content	Digit	Example
	Module serial number	1 -5	71549
	Module material number	6 - 11	142846
	Production order number	12 - 19	55054991
	Date code (production year)	20 -21	15
	Date code (production week)	22 -23	30
Example	 		
	71549142846550549911530		71549142846550549911530

图 3

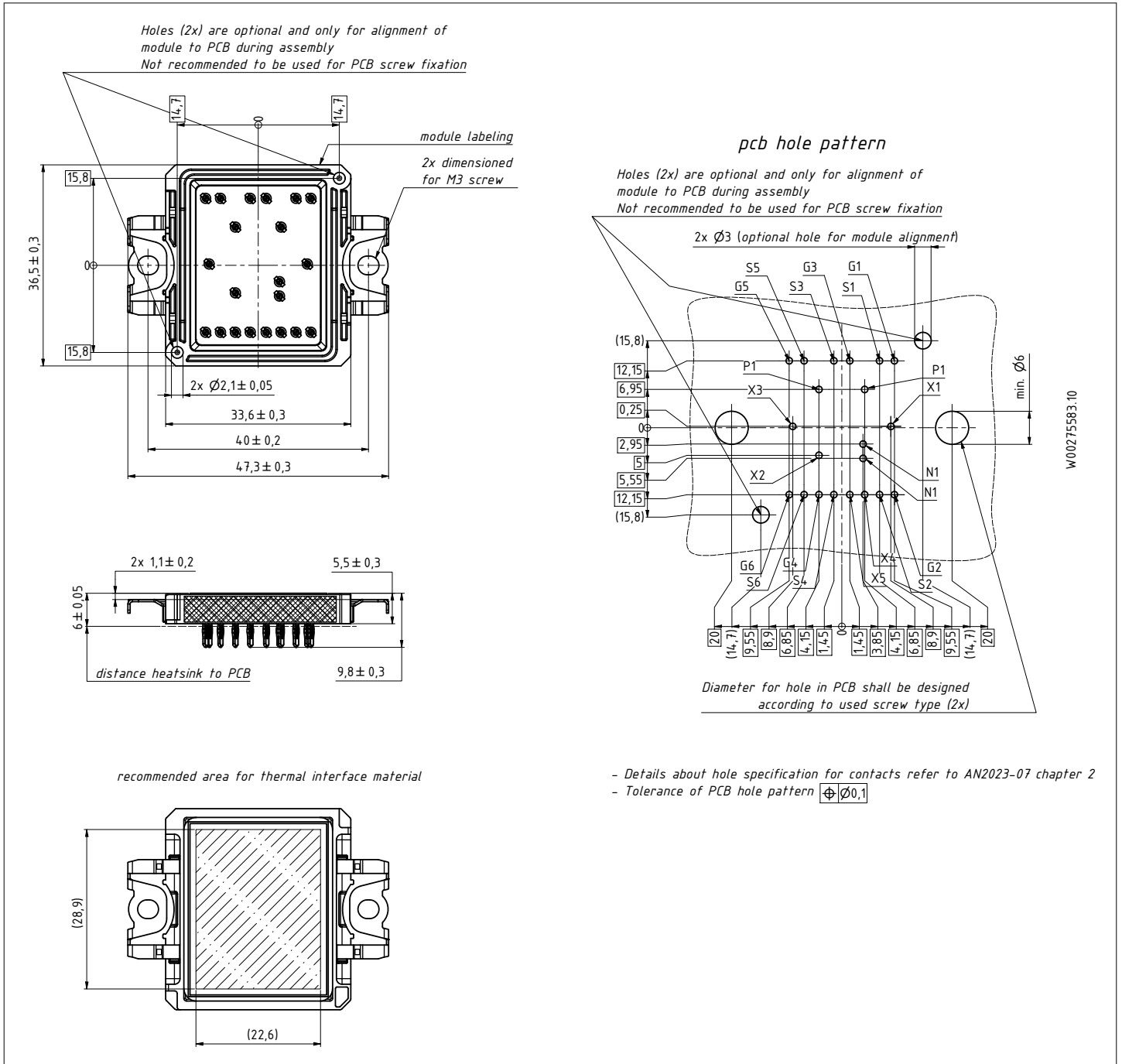
## 修订历史

修订版本	发布日期	变更说明
0.10	2025-11-13	Target datasheet
1.00	2026-04-02	Final Datasheet
1.01	2026-04-16	Correction of RTI
1.02	2026-04-20	Update of package outline

## Trademarks

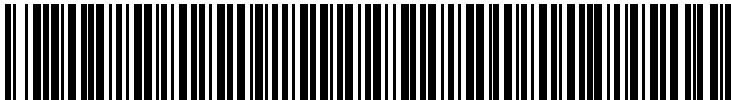
All referenced product or service names and trademarks are the property of their respective owners.

**Edition 2026-04-20**

**Published by**

**Infineon Technologies AG**

**81726 Munich, Germany**

**© 2026 Infineon Technologies AG**

**All Rights Reserved.**

**Do you have a question about any aspect of this document?**

**Email: [erratum@infineon.com](mailto:erratum@infineon.com)**

**Document reference**

**IFX-ABM405-004**

## 重要提示

本文件所提供的任何信息绝不应被视为针对任何条件或者品质而做出的保证（质量保证）。

英飞凌对于本文件中所提及的任何事例、提示或者任何特定数值及/或任何关于产品应用方面的信息均在此明确声明其不承担任何保证或者责任，包括但不限于其不侵犯任何第三方知识产权的保证均在此排除。

此外，本文件所提供的任何信息均取决于客户履行本文件所载明的义务和客户遵守适用于客户产品以及与客户对于英飞凌产品的应用所相关的任何法律要求、规范和标准。

本文件所含的数据仅供经过专业技术培训的人员使用。客户自身的技术部门有义务对于产品是否适宜于其预期的应用和针对该等应用而言本文件中所提供的信息是否充分自行予以评估。

## 警告事项

由于技术所需产品可能含有危险物质。如需了解该等物质的类型，请向离您最近的英飞凌科技办公室接洽。

除非由经英飞凌科技授权代表签署的书面文件中做出另行明确批准的情况外，英飞凌科技的产品不应被用于任何一项一旦产品失效或者产品使用的后当被用于任何一项一旦产品失效或者产品使用的后领域。