



## **XENSIV™ magnetic position sensors**

Exceptionally precise magnetic position sensors comprising industry-leading 3D, linear, angle, switches and latches

[www.infineon.com/magnetic-position-sensors](http://www.infineon.com/magnetic-position-sensors)



# Magnetic position sensors

## XENSIV™ exceptionally precise magnetic position sensors comprising industry-leading 3D, linear, angle, switches and latches.

Infineon XENSIV™ position sensors are exceptionally precise thanks to an industry-leading magnetic technology portfolio. Our benchmark and innovative magnetic sensor portfolio perfectly fits numerous automotive, industrial, and consumer customer applications. We produce all magnetic sensor technologies in-house; thus, our customers can choose between Hall sensors, anisotropic magnetoresistance (AMR), giant magnetoresistance (GMR), and tunnel magnetoresistance (TMR) sensors to find their best-fit solution for their application.

Generally, magnetic sensors measure the strength and/or direction of an applied magnetic field generated by, e.g., ferromagnetic materials and magnets, inductive coils like in motors, etc. The information on the measured field is processed within the sensor and converted into

strength, position, speed, angular, and/or direction information. The processed sensor information is transmitted to the application via specific analog or digital interfaces. A wide range of sensors is equipped with additional safety and diagnostic features, options with outstanding stray field robust performance, and ISO 26262-compliant developed.

Our portfolio includes a broad range of ISO 26262-compliant products meeting safety requirements as safety element out of context (SEooC) up to the highest safety level of ASIL D, as well as stray field robust sensors exceeding ISO 11452-1:20015. These are well perceived within the market and used in a wide range of automotive and industrial safety applications.



Click here to learn more:

[www.infineon.com/magnetic-position-sensors](http://www.infineon.com/magnetic-position-sensors)

# Switches and latches

Broadest energy saving portfolio of high precision magnetic switches and latches for automotive, industrial, and consumer applications

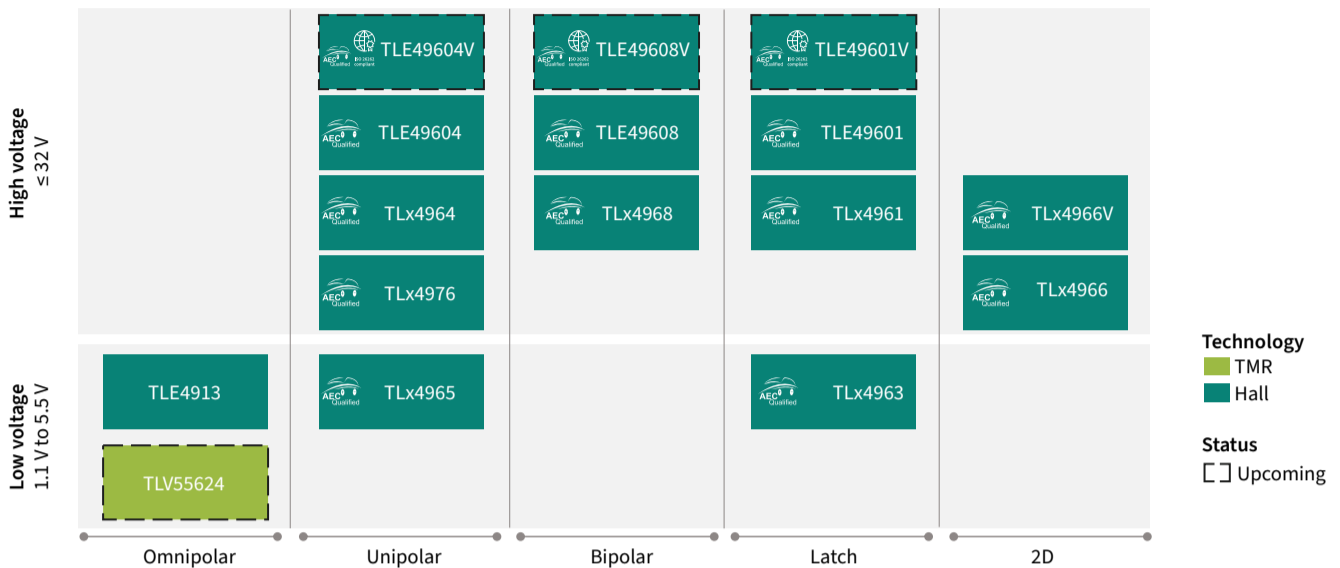

## TLx4961, TLx4964, TLE4968

### XENSIV™ energy-efficient magnetic switch family for up to 32 V

The TLx496x-xM/L family of magnetic switches and latches saves energy and enables designers to create precise and compact systems. With an operational current consumption of just 1.6 mA, TLx496x-xM/L products can cut energy consumption by up to 50 percent compared with similar competitor products. The family paves the way for precise system switching points thanks to its small magnetic hysteresis. The integrated temperature profile compensates for magnetic drifts and enables stable performance over temperature and lifetime.

TLx496x-xM products come in the smallest SOT23 package, reducing height by 10 percent compared with predecessor products on the market. The sensors also feature an integrated functionality test for better system control.

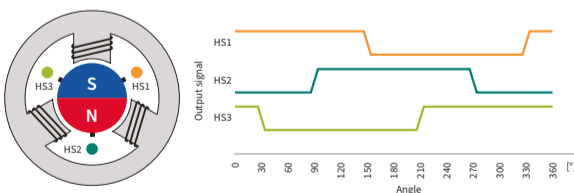

#### Features

- Current consumption of just 1.6 mA
- 3 to 32 V supply voltage range (overvoltage up to 42 V)
- 7 kV ESD protection (HBM)
- Overtemperature and overcurrent protection
- Temperature compensation
- Smallest SOT23 package on the market
- Dedicated products for industrial applications (TLI496x) and consumer (TLV496x)
- AEC-Q100 qualified

#### Applications

- Window lifter
- Power closing
- Gear stick
- Seat belt
- BLDC commutation (e.g., wiper, seat belt pretensioner, pump, seating)
- Service robots
- Power tools
- Home appliances



Click here to learn more:

[www.infineon.com/magnetic-position-sensors](http://www.infineon.com/magnetic-position-sensors)

[www.infineon.com/switches-latches](http://www.infineon.com/switches-latches)

Product	Type	Operating point $B_{OP}$ [mT]	Release point $B_{RP}$ [mT]	Hysteresis $\Delta B_{HY}$ [mT]	Automotive	Industrial	Consumer	Package
TLE4961-1M	Latch	2.0	-2.0	4.0	✓	✓	✓	SOT23
TLE4961-1L	Latch	2.0	-2.0	4.0	✓	✓	✓	SSO-3-2
TLE4961-2M	Latch	5.0	-5.0	10	✓	✓	✓	SOT23
TLE4961-3M	Latch	7.5	-7.5	15	✓	✓	✓	SOT23
TLE4961-3L	Latch	7.5	-7.5	15	✓	✓	✓	SSO-3-2
TLE4961-4M	Latch	10.0	-10.0	20	✓	✓	✓	SOT23
TLE4961-5M	Latch	15.0	-15.0	30	✓	✓	✓	SOT23
TLE4964-1M	Switch	18.0	12.5	5.5	✓	✓	✓	SOT23
TLE4964-2M	Switch	28.0	22.5	5.5	✓	✓	✓	SOT23
TLE4964-3M	Switch	12.5	9.5	3.0	✓	✓	✓	SOT23
TLE4964-4M	Switch	10.0	8.5	1.5	✓	✓	✓	SOT23
TLE4964-6M	Switch	3.5	2.5	1.0	✓	✓	✓	SOT23
TLE4964-5M	Switch	7.5	5.0	2.5	✓	✓	✓	SOT23
TLE4968-1M	Bipolar	1.0	-1.0	2.0	✓	✓	✓	SOT23
TLE4968-1L	Bipolar	1.0	-1.0	2.0	✓	✓	✓	SSO-3-2
TLI4961-1M	Latch	2.0	-2.0	4.0	-	✓	✓	SOT23
TLV4961-1M	Latch	2.0	-2.0	4.0	-	-	✓	SOT23
TLV4961-3M	Latch	7.5	-7.0	15.0	-	-	✓	SOT23
TLV4964-1M	Switch	18.0	12.5	5.5	-	-	✓	SOT23
TLV4964-2M	Switch	28.0	22.5	5.5	-	-	✓	SOT23



## TLx4963, TLx4965

### XENSIV™ 5 V high-precision Hall sensor for automotive/industrial applications

TLx496x-xM are integrated Hall-effect sensors specially designed for highly accurate applications. The sensors provide an easy-to-use and cost-effective solution for position sensing applications, requiring high-temperature stability of the magnetic threshold.

By offering an excellent magnetic behavior, Infineon's switches are ideally suited for:

- Index counting application with a pole wheel
- Rotor position detection (BLDC motors)
- Open/close detection

Target applications for TLx496x-xM are all applications requesting a precise magnetic latch or switch with a broad operating temperature range.

#### Features

- 3.0 to 5.5 V operating supply voltage
- Low current consumption 1.4 mA
- ESD protection 4 kV HBM
- Active error compensation (chopped)
- High stability of magnetic thresholds
- Low jitter (typ. 0.35  $\mu$ s)
- Operating temperature range:
  - from -40°C to +170°C (TLE496x-xM)
  - from -40°C to +125°C (TLI496x-xM)
- Small SMD package SOT23
- TLE: AEC-Q100 qualified
- TLI: JEDEC qualified

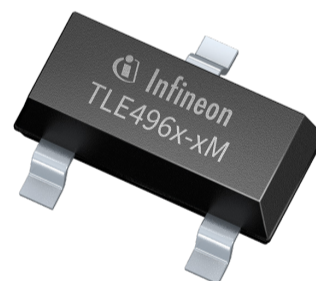

Product	Type	Operating point $B_{OP}$ [mT]	Release point $B_{RP}$ [mT]	Hysteresis $\Delta B_{HY}$ [mT]	Automotive	Industrial	Consumer	Package
TLE4963-1M	Latch	2.0	-2.0	4.0	✓	✓	✓	SOT23
TLE4963-2M	Latch	5.0	-5.0	10.0	✓	✓	✓	SOT23
TLE4965-5M	Unipolar switch	7.5	5.0	2.5	✓	✓	✓	SOT23
TLI4963-1M	Latch	2.0	-2.0	4.0	-	✓	✓	SOT23
TLI4963-2M	Latch	5.0	-5.0	10.0	-	✓	✓	SOT23
TLI4965-5M	Unipolar switch	7.5	5.0	2.5	-	✓	✓	SOT23



Click here to learn more:

[www.infineon.com/magnetic-position-sensors](http://www.infineon.com/magnetic-position-sensors)  
[www.infineon.com/switches-latches](http://www.infineon.com/switches-latches)

## TLV496x-xTA/B

### XENSIV™ precise Hall-effect sensor for consumer applications in leaded package

The TLV496x-xTA/B Hall-effect sensor family comprises a line of magnetic switches for contactless position sensing.

The sensors are specially designed to provide an easy-to-use and cost-effective solution for position sensing applications.

#### Features

- 3.0 to 26 V operating supply voltage
- Low current consumption 1.6 mA
- ESD protection 4 kV HBM
- Operating temperature range from -40°C to 125°C
- Leaded package TO92S

#### Applications

- BLDC motor commutation for consumer devices (e.g., e-bikes, fans, air conditioners)
- Position detection (e.g., flaps and control buttons)

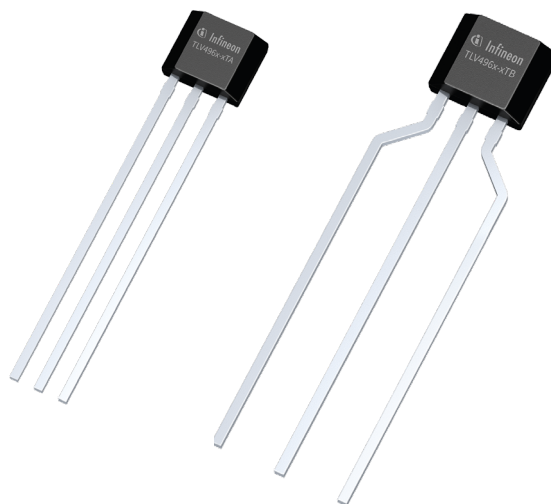

Product	Type	Operating point $B_{OP}$ [mT]	Release point $B_{RP}$ [mT]	Hysteresis $\Delta B_{HY}$ [mT]	Consumer	Package
TLV4961-1TA	Latch	2.0	-2.0	4.0	✓	TO92S-3-1
TLV4961-1TB	Latch	2.0	-2.0	4.0	✓	TO92S-3-2
TLV4961-3TA	Latch	7.5	-7.5	15.0	✓	TO92S-3-1
TLV4961-3TB	Latch	7.5	-7.5	15.0	✓	TO92S-3-2
TLV4964-4TA	Unipolar switch	10.0	8.5	1.5	✓	TO92S-3-1
TLV4964-4TB	Unipolar switch	10.0	8.5	1.5	✓	TO92S-3-2
TLV4964-5TA	Unipolar switch	7.5	5.0	2.5	✓	TO92S-3-1
TLV4964-5TB	Unipolar switch	7.5	5.0	2.5	✓	TO92S-3-2
TLV4968-1TA	Bipolar switch	1.0	-1.0	2.0	✓	TO92S-3-1
TLV4968-1TB	Bipolar switch	1.0	-1.0	2.0	✓	TO92S-3-2



Click here to learn more:

[www.infineon.com/magnetic-position-sensors](http://www.infineon.com/magnetic-position-sensors)

[www.infineon.com/switches-latches](http://www.infineon.com/switches-latches)



## TLx4966-xG family Two-in-one double Hall-effect sensor

Our XENSIV™ TLx4966-xG family features two integrated, calibrated sensor elements for detecting direction and counting indexes in one device. This two-in-one feature eliminates the need for a second sensor, cutting engineering and production costs. Using just one sensor ensures perfect alignment of the sensor elements, raising system quality and reliability.

### Features

- Two Hall probes in one package
- Excellent matching between the two Hall probes
- Hall plate distance of 1.45 mm
- Outstanding quality
- Information on direction and speed
- TSOP6 package
- AEC-Q100 qualified

### Applications

- Window lifter
- Sunroof
- Automatic tailgate
- Automated doors
- Sun blinds



Click here to learn more:

[www.infineon.com/magnetic-position-sensors](http://www.infineon.com/magnetic-position-sensors)  
[www.infineon.com/switches-latches](http://www.infineon.com/switches-latches)



## TLE4966V-1G

### XENSIV™ vertical dual-Hall switch

The Infineon vertical double Hall-effect switch TLE4966V-1G further develops the TLx4966-xG family. The vertical orientation of the Hall plates, resulting in in-plane field sensitivity, is completely new, enabling entirely new application layouts.

This device offers high-voltage capabilities with very low current consumption. It can be operated from unregulated power supplies, offering our customers unique design freedom for their systems. This product is AEC-Q100 certified, enabling our customers to build systems that meet the highest quality requirements.

#### Benefits

- Saves space
- Easy mounting of sensor and PCB board
- Allows increased mounting flexibility
- Enables new, compact system designs

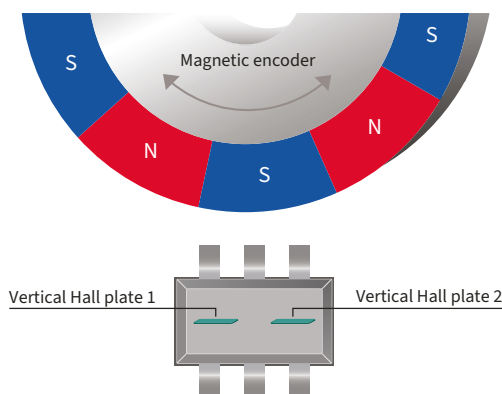

Product	Type	Output	Operating point $B_{OP}$ [mT]	Release point $B_{RP}$ [mT]	Hysteresis $\Delta B_{HY}$ [mT]	Automotive	Industrial	Consumer	Package
TLE4966G	Double Hall, speed and direction output	Speed and direction	7.5	-7.5	15	✓	✓	✓	TSOP6
TLE4966L	Double Hall, speed and direction output	Speed and direction	7.5	-7.5	15	✓	✓	✓	SSO-4-1
TLE4966-2G	Double Hall, two independent outputs	2 x speed	7.5	-7.5	15	✓	✓	✓	TSOP6
TLE4966-3G	Double Hall, speed and direction output	Speed and direction	2.5	-2.5	5.0	✓	✓	✓	TSOP6
TLE4966V-1G	Vertical double Hall, speed and direction output	Speed and direction	2.5	-2.5	5.0	✓	✓	✓	TSOP6
TLI4966G	Double Hall, speed and direction output	Speed and direction	7.5	-7.5	15	–	✓	✓	TSOP6



Click here to learn more:

[www.infineon.com/magnetic-position-sensors](http://www.infineon.com/magnetic-position-sensors)  
[www.infineon.com/switches-latches](http://www.infineon.com/switches-latches)

## TLx49x6

### XENSIV™ high-precision magnetic switches and latches

The TLx49x6 families comprise high-precision, unipolar Hall-effect switches and latches with different magnetic sensitivities.

TLx49x6 products have succeeded in many automotive, industrial, and consumer applications. The family includes two-wire sensors with a current interface.

#### Features

- Best-in-class quality
- Chopped Hall system for high sensitivity
- High jitter performance
- SMD and leaded packages
- Open collector or current interface
- Temperature compensation
- Up to 18 V supply
- Dedicated products for industrial (TLI49x6) and consumer applications (TLV49x6)
- AEC-Q100 qualified (TLE products)

#### Applications

- Power closing
- Gear stick
- Seat belt
- HVAC flap
- BLDC commutation
- Two-wheeler application

Product	Type	Operating point $B_{OP}$ [mT]	Release point $B_{RP}$ [mT]	Hysteresis $\Delta B_{HY}$ [mT]	Automotive	Industrial	Consumer	Package
TLE4906K	Unipolar switch	10.0	8.5	1.5	✓	✓	✓	SC59
TLE4906L	Unipolar switch	10.0	8.5	1.5	✓	✓	✓	SSO-3-2
TLE4906-2K	Unipolar switch	18.0	12.5	5.5	✓	✓	✓	SC59
TLE4906-3K	Unipolar switch	28.0	22.5	5.5	✓	✓	✓	SC59
TLE4946K	Latch	14.0	-14	28	✓	✓	✓	SC59
TLE4946-1L	Latch	15.0	-15	30	✓	✓	✓	SSO-3-2
TLE4946-2K	Latch	2.0	-2.0	4.0	✓	✓	✓	SC59
TLE4946-2L	Latch	2.0	-2.0	4.0	✓	✓	✓	SSO-3-2
TLE4976-1K	Unipolar switch/ Current interface	9.25	7.25	2.0	✓	✓	✓	SC59
TLE4976-2K	Unipolar switch/ Current interface	4.5	2.7	1.8	✓	✓	✓	SC59
TLV4976-2K	Unipolar switch/ Current interface	4.5	2.7	1.8	–	–	✓	SC59



Click here to learn more:

[www.infineon.com/magnetic-position-sensors](http://www.infineon.com/magnetic-position-sensors)

[www.infineon.com/switches-latches](http://www.infineon.com/switches-latches)

# ASIL B-compliant magnetic switches

**XENSIV™ ISO 26262-compliant switches with extended mounting flexibility enabling safety on application level up to ASIL B**

The TLE4960x family of magnetic Hall switches is a range of high-precision magnetic sensors designed for demanding automotive applications with extended safety requirements. The different sensor variants, sensitive in planar and orthogonal directions, achieve extended mounting flexibility on PCBs, making them a perfect solution for a wide range of applications.

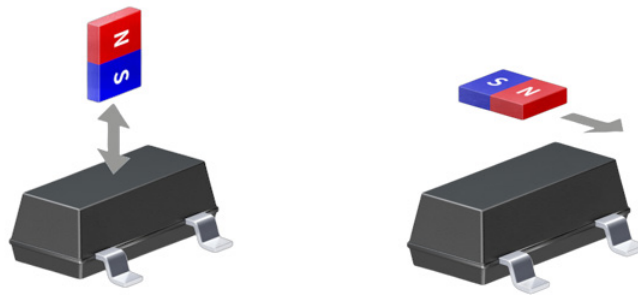

**Large portfolio of Hall switches allows a maximum of mounting flexibility**

The increasing electrification of vehicles, including safety-relevant areas such as steering and braking, has led to a growing concern about safety and redundancy in the automotive sector. The smallest errors in one magnetic sensor can lead to the failure of an entire system. The TLE4960x family sensors have been developed per ISO 26262 standard to address this issue, avert harm under all possible circumstances, and meet the ASIL B metric on a chip level as a safety element that is out of context. Therefore, sensors are equipped with a fully ASIL B-compliant internal diagnosis and a periodically sent life tick, which can be evaluated externally at the application level to detect faults. The evaluation of the sensor signals is particularly smart and cost-effective since both the magnetic switching signal and the safety diagnostic signals are transmitted via a single output, enabling drop-in replacements for conventional magnetic switches.

The TLE4960x family is designed for various automotive applications, including window lifters, gear sticks, steer-bywire and motor commutation. Some derivatives can be operated in two-wire mode, requiring only a minimum of two wires between the controller unit and sensor, especially for remote peripheral devices inside automotive solutions.



**Click here to learn more:**

[www.infineon.com/magnetic-position-sensors](http://www.infineon.com/magnetic-position-sensors)

[www.infineon.com/switches-latches](http://www.infineon.com/switches-latches)

## TLE4960x

### XENSIV™ ASIL B-compliant magnetic switches with open drain interface

#### Upgrade your safety and flexibility in cars

Infineon has launched the pilot ASIL B magnetic switch family, which measures the magnetic field orthogonal to the PCB direction in the Z direction. This sensor family is developed according to ISO 26262 and provides built-in diagnosis functions to support functional safety applications with requirements up to ASIL B. It is also AEC-100 compliant and Grade 0 qualified.

The very small SOT23 package reduces overall system cost and ensures design flexibility. By using TLE4960x, safety and flexibility can be redefined in multiple car applications, such as window lifts, sunroofs, power closure actuators, seat positioning, and seat belt pre-tensioners.

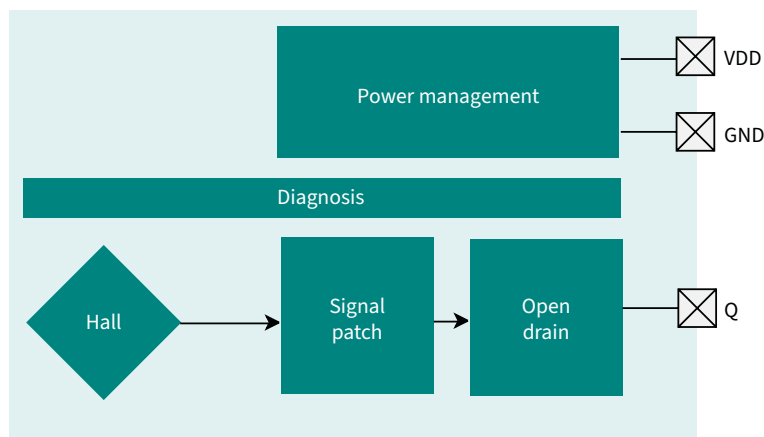

#### Features and benefits

##### Key features

- Meets safety standard up to ASIL B
- Smallest automotive-qualified SMD package on the market
- Broad portfolio of specialized sensors for all kind of applications
- Online simulation tool to ensure short design cycles
- Lowest best-in-class effective noise

##### Key benefits

- Increased reliability means less fails at the end-customer within warranty time
- Reduces system cost, increases flexibility, and enables small designs
- Ensures easy replacement and enables supplier flexibility
- Allows first time right designs and ensures fast time to market
- Enables a very accurate time critical switching

#### Product portfolio

Product	Description	Package	ISO 26262	Orientation	Ordering code
TLE49601-1M-S2	Latch with Bop/Brp (2/-2 mT)	SOT23-3	ASIL B	Z	SP005924303
TLE49601-3M-S2	Latch with Bop/Brp ( 7.5/-7.5 mT)	SOT23-3	ASIL B	Z	SP005924485
TLE49601-5M-S2	Latch with Bop/Brp (15/-15 mT)	SOT23-3	ASIL B	Z	SP005924491
TLE49604-1M-S2	Unipolar switch with Bop/Brp (18/12.5 mT)	SOT23-3	ASIL B	Z	SP005924627
TLE49604-2M-S2	Unipolar switch with Bop/Brp (28.0/22.5 mT)	SOT23-3	ASIL B	Z	SP005924552
TLE49604-4M-S2	Unipolar switch with Bop/Brp ( 10/8.5 mT)	SOT23-3	ASIL B	Z	SP005924634
TLE49604-6M-S2	Unipolar switch with Bop/Brp ( 3.5/2.5 mT)	SOT23-3	ASIL B	Z	SP005924642
TLE49604-7M-S2	Unipolar switch with Bop/Brp (9.5/7 mT)	SOT23-3	ASIL B	Z	SP005924558
TLE49608-1M-S2	Bipolar switch with Bop/Brp (1/-1 mT)	SOT23-3	ASIL B	Z	SP005924532



Click here to learn more:

[www.infineon.com/magnetic-position-sensors](http://www.infineon.com/magnetic-position-sensors)  
[www.infineon.com/switches-latches](http://www.infineon.com/switches-latches)



## 3D sensors

Infineon's XENSIV™ 3D sensors (TLx493D-xxxx) combine high-accuracy magnetic field measurements with an extremely compact footprint and exceptionally low power consumption (typ. 7 nA). Our sensors open up a lot of exciting new use cases, including innovative human-machine interfaces in the form of industrial joysticks, ergonomic pushbuttons on domestic appliances and highly precise position control in robotics.

XENSIV™ TLE493D-P3I8 /-P3B6 /-W3B6 is our latest magnetic 3D sensor, enabled by new and improved accuracy. With respect to pricing and package size, it is the best product for high-performance applications.

The TLE493D-P3I8 /-P3B6 /-W3B6 has an extremely low current consumption and a wake-up function in a small package. Also, the sensor provides configuration options to best fit customer requirements (e.g., data communication, definition of measurements, etc.). The ISO 26262 compliance includes the safety manual and supports functional safety applications. The configurability of the sensor is used in application platforms to adapt to end customer wishes. TLE493D-P3I8 /-P3B6 /-W3B6 is available in 4 different address variants. It is possible to connect up to 4 sensors to one I<sup>2</sup>C bus.



Click here to learn more:

[www.infineon.com/magnetic-position-sensors](http://www.infineon.com/magnetic-position-sensors)  
[www.infineon.com/3d-sensors](http://www.infineon.com/3d-sensors)

# XENSIV™ 3D sensors for consumer and industrial applications

The TLx493D-AxB6 sensor realizes accurate three-dimensional sensing with extremely low power consumption in a small package. Capable of detecting the magnetic field in the x, y, and z-directions, the sensor is ideally suited for the measurement of linear, rotational, or three-dimensional movements. Thanks to its small package and low power consumption, the TLx493D-AxB6 can be used in new applications, replacing potentiometers and optical solutions. Featuring contactless position sensing and high-temperature stability of the magnetic measurement, the sensor allows systems to get smaller, more accurate, and more robust.

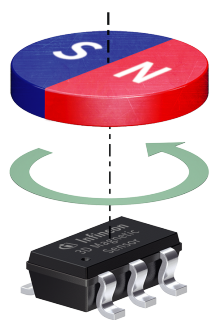
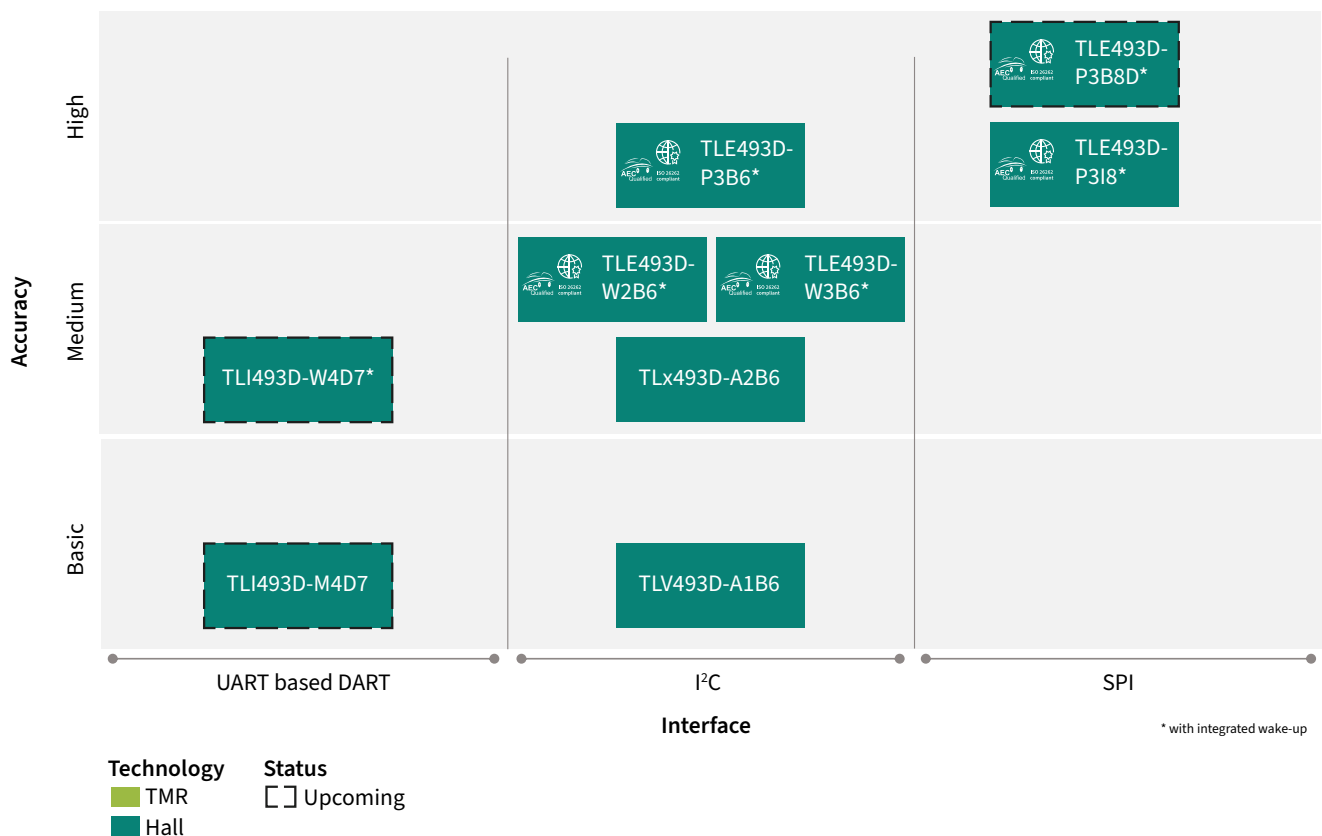

Rotation movement

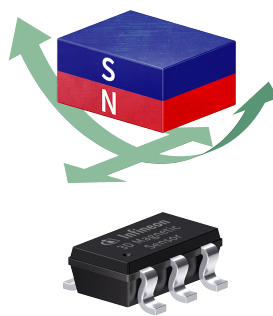

3D movement

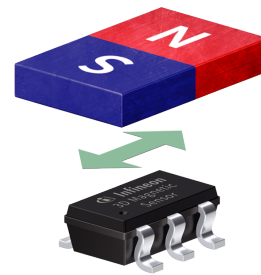

Linear movement



Click here to learn more:

[www.infineon.com/magnetic-position-sensors](http://www.infineon.com/magnetic-position-sensors)

[www.infineon.com/3d-sensors](http://www.infineon.com/3d-sensors)

## Features

- 3D magnetic sensing
- Integrated temperature sensing
- Low current consumption
  - 7 nA in power-down mode
- 2.8 to 3.5 V operating supply voltage
- Digital communication via a 2-wire standard I<sup>2</sup>C interface
- Bx, By, and Bz linear field measurement up to ±160 mT
- JESD47 qualified
- 12-bit data resolution for each measurement direction
- Various resolution options from 32 to 130 μT/LSB<sub>12</sub>
- Operating temperature range from -40°C to 125°C

Product	Temperature range	Qualification	Linear magnetic range	Resolution	I <sub>DD</sub>	Update rate XYZ measurement	Package	Ordering code
TLI493D-A2B6	-40 ... 105°C	JESD47	±100 mT ±160 mT	7.7 or 15.4 LSB <sub>12</sub> /mT	7 nA – 3.4 mA	up to 8.4 kHz	TSOP6	SP001689844
TLV493D-A1B6	-40 ... 125°C	JESD47	±130 mT	10.2 LSB <sub>12</sub> /mT	7 nA – 3.7 mA	up to 3.3 kHz	TSOP6	SP001286056

## New features

- Advanced operation modes to provide high flexibility
- Short mode range setting, focusing on the half of the magnetic range, ensuring higher accuracy
- Higher update frequency allows for an application field that requires faster update speed
- Angular mode (for x and y measurement only)

## Applications

- Anti-tampering protection in smart meters
- Joysticks
- CCTV-control, game consoles
- Control elements e.g., white goods multifunction knobs
- Ergonomic push- and control buttons on domestic appliances and power tools
- Position control in robotics
- Smart lock position detection
- Tactile sensing for grippers and dexterous robot hands



Click here to learn more:

[www.infineon.com/magnetic-position-sensors](http://www.infineon.com/magnetic-position-sensors)

[www.infineon.com/3d-sensors](http://www.infineon.com/3d-sensors)

# XENSIV™ 3D sensors for automotive applications

Infineon's TLE493D-xxxx enables automotive control element applications within the passenger compartment or under the hood with a temperature range of -40°C up to +150°C, with linear magnetic range requirements up to ±160 mT.

## Features

- 3D magnetic sensing
- Integrated temperature sensing
- 2.8 to 5.5 V operating supply voltage
- Low current consumption
  - 7 nA in power-down mode
  - Up to 10 power modes
- Digital output via I<sup>2</sup>C or SPI interface
- Bx, By, and Bz linear field measurement ±160 mT
- AEC-Q100 qualified
- Up to 14-bit data resolution for each measurement direction
- Various resolution options from 8.5 μT/LSB<sub>14</sub> to 130 μT/LSB<sub>2</sub>
- Operating temperature range from -40°C up to +150°C
- ISO 26262-compliant for ASIL B

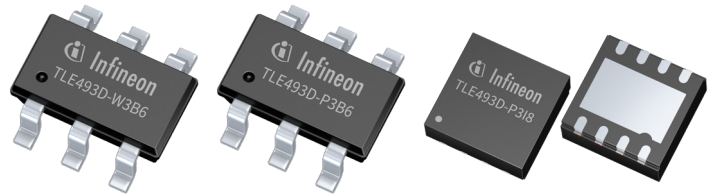

## Applications

- Control elements for infotainment/navigation systems, air conditioners, multifunctional steering wheels, seat controls
- Top column modules e.g., direction indicator, wiper control
- Gear stick position sensing
- Multi-function knobs
- Pedal/valve position sensing

Product	Supply voltage [V]	Interface	Qualification	Magnetic range (Selectable) [mT]	Sensitivity drift [%]	Matching drift X to Y [%]	Matching drift X/Y to Z [%]	Wake-up	Package	Ordering code
TLE493D-A2B6	2.8-3.5	I <sup>2</sup> C	AEC-Q100	±160 ±100	±5	±3.5	±10	No	TSOP6	SP001689848
TLE493D-W286 A0 TLE493D-W286 A1 TLE493D-W286 A2 TLE493D-W286 A3	2.8-3.5	I <sup>2</sup> C	AEC-Q100 ISO 26262-ready	±160 ±100	±5	±3.5	±10	Yes	TSOP6	SP001655334 SP001655340 SP001655344 SP001655348
TLE493D-W3B6 B0 TLE493D-W3B6 B1 TLE493D-W3B6 B2 TLE493D-W3B6 B3	2.8-3.5	I <sup>2</sup> C	AEC-Q100 ISO 26262-compliant ASIL-B	±160 ±100 ±50	±5	±1	±10	Yes	TSOP6	SP005952965 SP005952969 SP005952973 SP005952977
TLE493D-P3B6 A0 TLE493D-P3B6 A1 TLE493D-P3B6 A2 TLE493D-P3B6 A3	2.8-3.5	I <sup>2</sup> C	AEC-Q100 ISO 26262-ready ASIL-B	±160 ±100 ±50	±5	±1.7	±6.75	Yes	TSOP6	SP005427119 SP005427121 SP005427123 SP005427125
TLE493D-P3I8	2.8-3.5	I <sup>2</sup> C	AEC-Q100 ISO 26262-ready ASIL-B	±160 ±100 ±50	±5	±1.7	±6.75	Yes	VSON-8	SP005633649



ISO 26262  
compliant



Click here to learn more:

[www.infineon.com/magnetic-position-sensors](http://www.infineon.com/magnetic-position-sensors)  
[www.infineon.com/3d-sensors](http://www.infineon.com/3d-sensors)



## Linear sensors

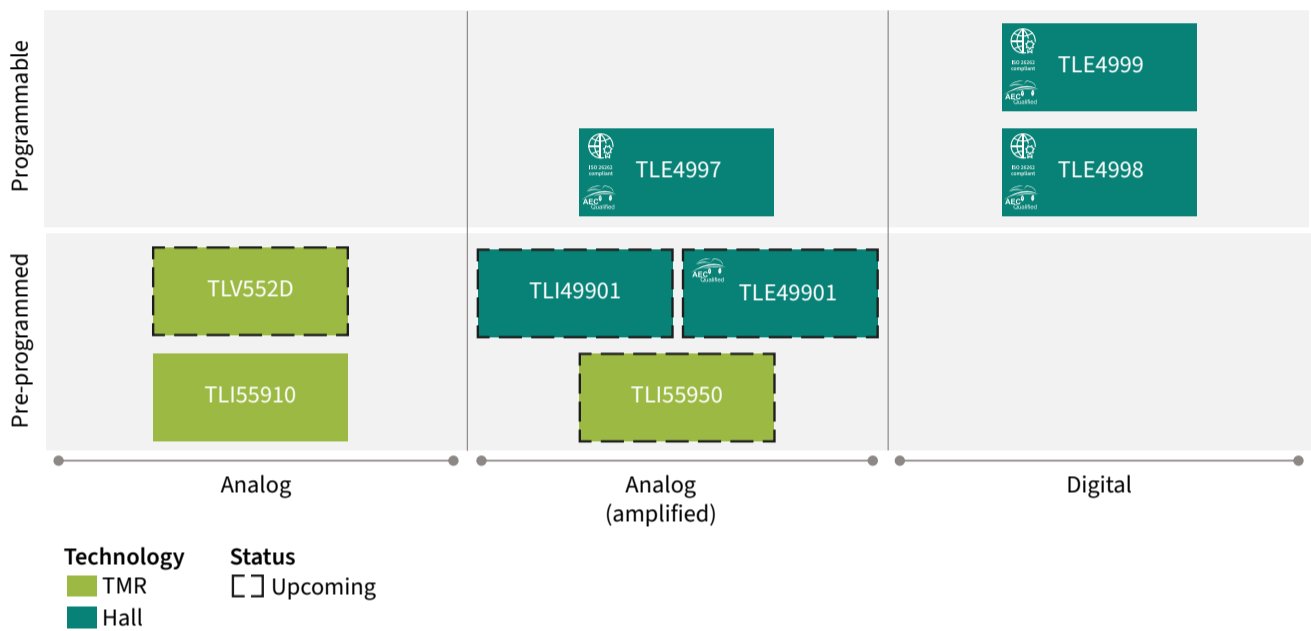

### XENSIV™ TLE4999C8 programmable dual channel linear Hall sensor with fast SPC interface for high precision applications

Infineon's TLE4999C8 is a programmable dual-channel linear Hall sensor designed to meet the requirements of safety-critical automotive and industrial applications. It is developed in full compliance with ISO 26262 using two sensor elements included within one monolithic silicon design. The sensor cells are designed to complement the state-of-the-art safety requirements at the system level and enable ASIL D system developments. Their signals follow two independent analog paths. Each signal path has a digital signal processing unit to ensure maximum independence (redundancy, respectively). The sensor offers a multi-point calibration with up to 9 selectable set points for enhanced linearization of the output signal. The chip provides five different calibration characteristics for an easy and flexible adaptation to the non-linearity of magnetic circuit design.

TLE4999C8 features a digital Short-PWM Code (SPC) interface with a bus capability for up to 4 sensor ICs on a single data output. The communication interface with a minimum 0.5  $\mu$ s unit time guarantees a fast transmission of a complete two-channel data signal in less than 500  $\mu$ s. The additionally implemented frame holder circuit enables the synchronicity of multiple sensors (e.g., in combination with angle sensors) via an SPC bus. The chip offers a 12-, 14- and 16-bit output signal resolution, ensuring the highest flexibility and superior noise performance.

An integrated digital temperature and stress compensation achieves the highest accuracy over a wide temperature range and lifetime. The chip is available in a thin 8-pin SMD single-sensor package.



Click here to learn more:

[www.infineon.com/magnetic-position-sensors](http://www.infineon.com/magnetic-position-sensors)  
[www.infineon.com/linear-sensors](http://www.infineon.com/linear-sensors)

Block diagram

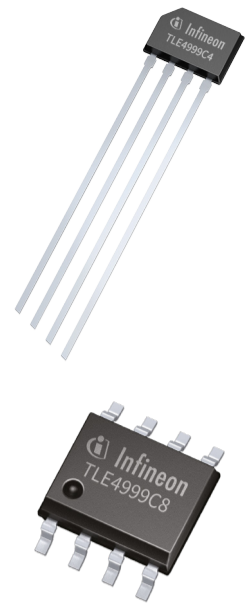
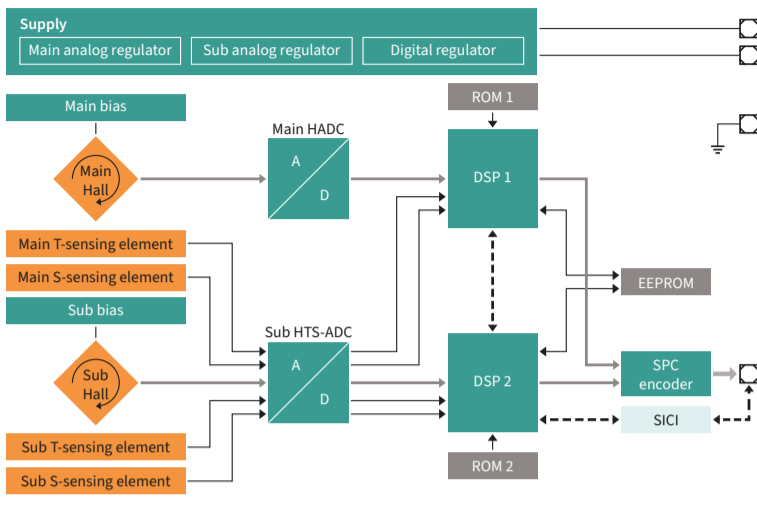

Features

- Fully ISO 26262-compliant, supports ASIL D systems
- <2% sensitivity drift, <100  $\mu$ T offset drift over temperature and lifetime
- Integrated digital temperature- and stress-compensation
- Fast digital SPC interface (unit time 0.5–3.0  $\mu$ s)
- Multi-point calibration with up to nine linearization set points

Benefits

- High diagnostic coverage, ISO 26262-compliance and dual sensor cell integration enable development of fail operational systems
- Multi-point calibration for better fit into various magnetic circuit designs
- Easy system integration due to programmability of several sensor parameters

Applications

Automotive safety critical applications

- Electric power steering
- Linear movement position sensing
- Pedal position
- Electric throttle control
- Seat rail adjustment
- Headlight adjustment

Industrial applications

- Small home appliances
- Joystick applications

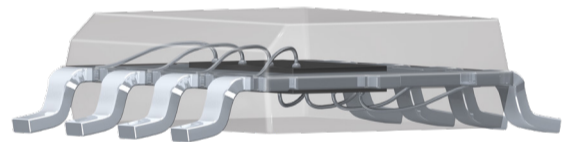

ISO 26262-ready/compliant dual channel linear sensors

Product	Interface	Magnetic linear range [mT]	Sensitivity	Sensitivity drift [%]	Gain	Magnetic offset drift [ $\mu$ T] <sup>1)</sup>	Classification	Ordering code	Package
TLE4997A8D	Analog ratiometric	50, 100, 200	$\pm 60$ mV/mT default for 100 mT range, with gain 1.5	$\pm 3$	$\pm 4$	$\leq \pm 400$	ISO 26262-ready	SP000902760	TDSO-8
TLE4998S8D	Digital interface SENT	50, 100, 200	$\pm 48$ LSB <sub>12</sub> /mT default for 100 mT range, with gain 1.5	$\pm 2$	$\pm 4$	$\leq \pm 400$	ISO 26262-ready	SP000902784	TDSO-8
TLE4998C8D	Digital interface SPC	50, 100, 200	$\pm 48$ LSB <sub>12</sub> /mT default for 100 mT range, with gain 1.5	$\pm 2$	$\pm 4$	$\leq \pm 400$	ISO 26262-ready	SP000902768	TDSO-8
TLE4999I3	Digital interface PSi5	12.5, 25	$\pm 147.5$ LSB <sub>13</sub> /mT default for 25 mT range, with gain 1.5	$\pm 2$	$\pm 7.59$	$\leq \pm 100 / \leq \pm 200$ <sup>2)</sup>	ISO 26262-compliant	SP001689862	SSO-3
TLE4999C8 (TLE4999C8-S0001)	Digital interface SPC	25, 50	$\pm 36.875$ LSB <sub>12</sub> /mT default for in 50 mT range, with gain 1.0	$\pm 2$	$\pm 7.59$	$\leq \pm 100 / \leq \pm 200$ <sup>2)</sup>	ISO 26262-compliant ASIL D (ASIL C)	SP002662500 (SP005727371)	TDSO-8
TLE4999C4 (TLE4999C4-S0001)	Digital interface SPC	25, 50	$\pm 36.875$ LSB <sub>12</sub> /mT default for in 50 mT range, with gain 1.0	$\pm 2$	$\pm 7.59$	$\leq \pm 100 / \leq \pm 200$ <sup>2)</sup>	ISO 26262-compliant ASIL D (ASIL C)	SP003420076 (SP005727375)	SSO-4

1) Maximum drift over temperature and lifetime

2) Main channel/sub channel



ISO 26262 ready



ISO 26262 compliant



Click here to learn more:

[www.infineon.com/magnetic-position-sensors](http://www.infineon.com/magnetic-position-sensors)

[www.infineon.com/linear-sensors](http://www.infineon.com/linear-sensors)

## TLE499x

### XENSIV™ programmable analog/digital single channel linear Hall sensor family

Infiniteon's family of TLE499x linear Hall ICs is tailored to the needs of highly accurate angular and linear position detection and current measurement applications. Each product measures the vertical component of a magnetic field and outputs a signal that is directly proportional to the magnetic field. These programmable linear Hall sensors come with different interface options: TLE4997 features ratiometric analog output, while TLE4998P comes with pulse width modulation (PWM), TLE4998S with single-edge nibble transmission (SENT), and TLE4998C with short PWM codes (SPC).

These high-precision 12-bit resolution for TLE4997 and 16-bit resolution for TLE4998 linear Hall sensors feature EEPROM memory for flexible programming across a wide range of parameters.

These sensors deliver outstanding temperature stability compared with similar compensation methods, thanks to digital signal processing based on a 20-bit DSP architecture and digital temperature compensation. TLE4998 also includes stress compensation to withstand stress effects from the package, such as moisture, thus ensuring best-in-class accuracy over the device's lifetime.

#### Features

- Best-in-class accuracy with low drift of output signal temperature range lifetime (including stress compensation in TLE4998)
- Programmable transfer function (gain, offset), clamping, bandwidth, and temperature characteristics
- AEC-Q100 qualified
- Available in various packages including SSO-3-9 with two integrated capacitors to improve ESD and ESC behavior
- For ISO 26262-ready, choose TLE4997, TLE4998

#### Applications and use cases

- Detecting linear and angular position
- Detecting pedal and throttle position
- Steering torque measurement
- Headlight leveling
- High-current sensing
- Seat position and occupant detection
- Suspension control
- Detecting gear stick/lever positions
- Detecting liquid levels in fuel tanks
- Current sensing e.g., for battery management

Product	Programm.	Number of pins	Sensitivity (programmable range)	Magnetic offset	Supply voltage (extended range)	Automotive	Classification	Interface	Package
TLE4997	EEPROM	3/Single die SMD 8	±12.5 to ±300 mV/mT	<±400 μT	5 V ±10% (7 V)	✓	ISO 26262-ready	Analog	SSO-3-10 TDSO-8
TLE4998P	EEPROM	3/4/Single die SMD 8	±0.2 to ±6%/mT	<±400 μT	5 V ±10% (16 V)	✓	ISO 26262-ready	PWM	SSO-3 SSO-4 SSO-3 (2 capacitors) TDSO-8
TLE4998S	EEPROM	3/4/Single die SMD 8	±8.2 to ±245 LSB <sub>12</sub> /mT	<±400 μT	5 V ±10% (16 V)	✓	ISO 26262-ready	SENT	SSO-3 SSO-4 SSO-3 (2 capacitors) TDSO-8
TLE4998C	EEPROM	3/4/Single die SMD 8	±8.2 to ±245 LSB <sub>12</sub> /mT	<±400 μT	5 V ±10% (16 V)	✓	ISO 26262-ready	SPC	SSO-3 SSO-4 SSO-3 (2 capacitors) TDSO-8

1) 147.44 LSB<sub>13</sub> converts to 294.88 LSB<sub>12</sub>



ISO 26262  
ready



Click here to learn more:

[www.infineon.com/magnetic-position-sensors](http://www.infineon.com/magnetic-position-sensors)  
[www.infineon.com/linear-sensors](http://www.infineon.com/linear-sensors)

# TMR-based linear sensors

## XENSIV™ TLI55910 non-amplified TMR sensors

The TLI55910 is a high-sensitivity and low-power linear position sensor that leverages tunnel magnetoresistance (TMR) technology to deliver precise linear measurements. This non-amplified analog sensor can measure magnetic fields within a range of  $\pm 35$  mT and boasts a large ratiometric output sensitivity of 5 mV/V/mT. Additionally, the sensor has a low noise level of 5  $\mu$ VRMS, which helps to minimize errors and ensure reliable measurements. The sensor's low power consumption of 0.25 mA at 1.8 V<sub>DD</sub> makes it suitable for battery-powered devices or applications where power consumption is a concern. The TLI55910 sensor complies with JEDEC JESD47 and is available in a compact SOT23-6 package.

The TLI55910 is a versatile solution for various position-sensing applications, including industrial automation, consumer electronics, game controllers, home appliances and medical devices. The sensor is suitable for applications where low power consumption, high accuracy and reliability are beneficial. It can be used for linear, angle and rotary position sensing, displacement measurement, and motor control. It can enhance precision in machinery and robotic systems, improve user experiences in consumer electronics such as game controllers, provide precise feedback for efficient motor operation and ensure accurate and reliable measurements, even in harsh environments.

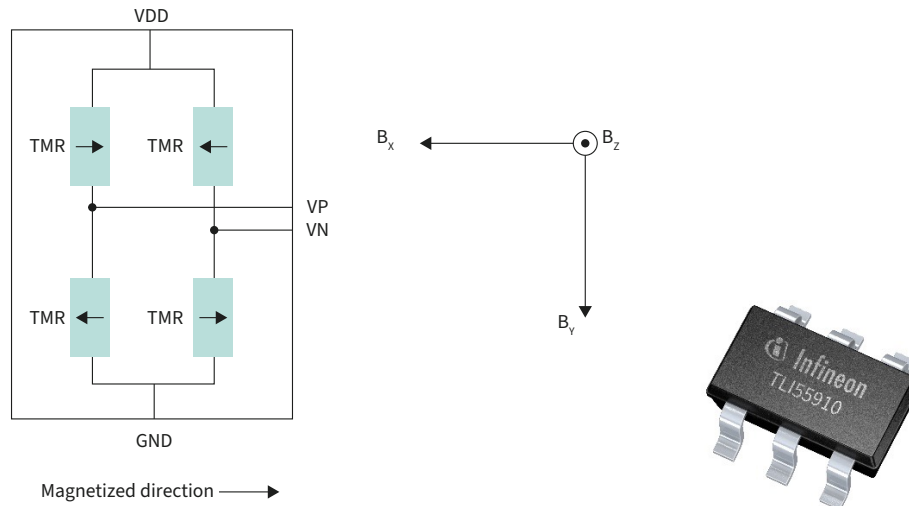

### Features and benefits

#### Key features

- High signal-to-noise ratio (SNR)
- Low power consumption (0.25 mA at 1.8 V<sub>DD</sub>)
- Magnetic measurement range of  $\pm 35$  mT
- Strong cross-field immunity
- Very low temperature drift characteristic

#### Key benefits

- Enables precise measurements
- Ideal for battery-powered devices
- Allows small and cost-effective magnet design
- Robustness against magnetic influences
- Stable measurements and operation even in harsh environments

Product	Interface	Magnetic linear range [mT]	Sensitivity [mV/V/mT]	Non-linearity [%]	Offset [mV/V <sub>DD</sub> ]	Classification	Ordering code	Package
TLI55910	Analog	$\pm 35$	5	$\pm 1.8$	10	JEDEC JESD47	SP006118939	PG-SOT23-6



Consumer



Game controller



Home appliance



Automation



Click here to learn more:

[www.infineon.com/magnetic-position-sensors](http://www.infineon.com/magnetic-position-sensors)  
[www.infineon.com/linear-sensors](http://www.infineon.com/linear-sensors)

## TLI55950 XENSIV™ linear TMR sensor with amplified output

The TLI55950 is a Tunnel Magnetoresistance (TMR)- based magnetic linear sensor with an integrated operational amplifier, providing a single-ended full-range voltage output suitable for high-sensitivity sensing applications. It features a linear position sensor in a universal SOT23-6 package, 5 V and 3.3 V supply voltages, and a magnet range with full-scale output amplitudes of  $\pm 41/25$  mT and  $\pm 25/16$  mT. The sensor has a high sensitivity of up to 85.5 mV/mT and ultralow noise of 4.1  $\mu$ TRMS, making it suitable for applications such as power tool trigger detection, service robots and drones angle sensing, and a high-precision dual-encoder setup.

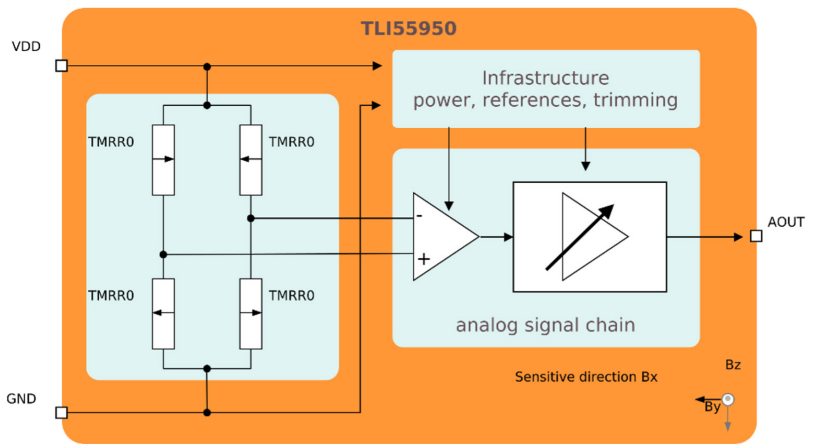

### Features and benefits

#### Key features

- High sensitivity due to integrated operational amplifier
- High accuracy and low noise (4.1  $\mu$ TRMS)
- High linearity ( $\pm 1.8\%$  full range)
- Low drift and strong cross-field immunity

#### Key benefits

- Flexible magnet choice and reduce the needs for external OpAmp
- Precise measurements
- Robust and high reliability
- Stable measurements and operation even in harsh environment

Sales name	Interface	Supply Voltage	Magnetic linear range [mT]	Sensitivity [ mV/mT ]	Classification	Ordering code	Package
TLI55950-AE6-E001	Analog	5 V and 3.3 V	$\pm 41/\pm 25$	53.5	JEDEC JESD47	SP006153153	PG-SOT23-6
TLI55950-AE6-E002	Analog	5 V and 3.3 V	$\pm 25/\pm 16$	85.5	JEDEC JESD47	SP006206460	PG-SOT23-6



Gimbal



Robotics



Home & building automation



Smart factory



Click here to learn more:

[www.infineon.com/magnetic-position-sensors](http://www.infineon.com/magnetic-position-sensors)  
[www.infineon.com/linear-sensors](http://www.infineon.com/linear-sensors)

## TLE/TLI49901 – Analog linear sensors XENSIV™ linear Hall sensor IC with analog output in 3-Pin SOT23 package

XENSIV™ TLE49901 (automotive) and TLI49901 (industrial) are linear Hall-effect sensors in BiCMOS technology with a ratiometric analog output, delivering stable, high-resolution position measurement in automotive and industrial applications. The sensors sense magnetic fields perpendicular to the top side, providing an output voltage proportional to the supply voltage and the applied magnetic field.

There are two versions available: Automotive and industrial, each with four different factory-programmed sensitivities, providing flexibility for different designs and customer requirements. The XENSIV™ analog linear sensors TLE/TLI49901 are suitable for applications that require high accuracy and can operate across an extended temperature range. The sensors offer low noise and a large signal bandwidth of up to 20 kHz. All variants are available in a compact 3-pin SOT23 surface-mount package and are pin-compatible with existing market solutions. The products have high accuracy with low sensitivity drift over temperature and lifetime, enabling precise measurements and reliable systems even in harsh environments.

Typical use cases include HMI controls such as knobs, buttons, and sliders, as well as pedal and valve position sensing in automotive and industrial systems. The sensors are also well-suited for motor commutation, drone gimbals, game controller joysticks and triggers and various linear and angle sensing use cases.

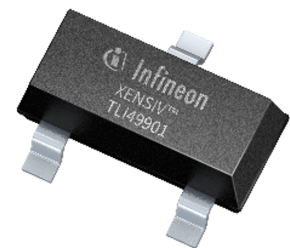
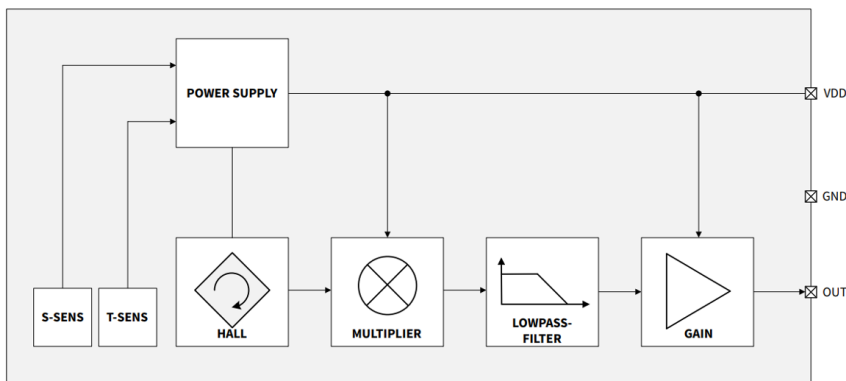

### Features and benefits

#### Key features

- Analog ratiometric output
- Best-in-class accuracy ~ 5% error over temperature and lifetime
- Low offset and offset drift
- High bandwidth
- Standard SOT23-3 package

#### Key benefits

- ADC with internal low-cost reference voltage can be used
- Precise measurements
- High reliability, even in harsh environments
- Accurate measurements even in high frequency signals
- Pin-to-pin comparable with common linear Hall sensors on the market



HMI



Power sliding door



Game controller



Home & building automation



Click here to learn more:

[www.infineon.com/magnetic-position-sensors](http://www.infineon.com/magnetic-position-sensors)  
[www.infineon.com/linear-sensors](http://www.infineon.com/linear-sensors)



### TLI49901 for Automotive

Sales name	Interface	Supply Voltage	Magnetic linear range [mT]	Sensitivity [ mV/mT ]	Classification	Ordering code	Package
TLE49901-1M	Analog	3.3 V and 5 V	±45	50 (VDD = 5 V) 33 (VDD = 3.3 V)	Automotive	SP006041489	PG-SOT23-3
TLE49901-2M	Analog	3.3 V and 5 V	±72	31.25 (VDD = 5 V) 20.6 (VDD = 3.3 V)	Automotive	SP006041498	PG-SOT23-3
TLE49901-3M	Analog	3.3 V and 5 V	±90	25 (VDD = 5 V) 16.5 (VDD = 3.3 V)	Automotive	SP006041506	PG-SOT23-3
TLE49901-4M	Analog	3.3 V and 5 V	±180	12.5 (VDD = 5 V) 8.25 (VDD = 3.3 V)	Automotive	SP006041510	PG-SOT23-3



### TLI49901 for Industrial and Consumer

Sales name	Interface	Supply Voltage	Magnetic linear range [mT]	Sensitivity [ mV/mT ]	Classification	Ordering code	Package
TLI49901-1M	Analog	3.3 V and 5 V	±45	50 (VDD = 5 V) 33 (VDD = 3.3 V)	Industrial	SP006041535	PG-SOT23-3
TLI49901-2M	Analog	3.3 V and 5 V	±72	31.25 (VDD = 5 V) 20.6 (VDD = 3.3 V)	Industrial	SP006041539	PG-SOT23-3
TLI49901-3M	Analog	3.3 V and 5 V	±90	25 (VDD = 5 V) 16.5 (VDD = 3.3 V)	Industrial	SP006041544	PG-SOT23-3
TLI49901-4M	Analog	3.3 V and 5 V	±180	12.5 (VDD = 5 V) 8.25 (VDD = 3.3 V)	Industrial	SP006041548	PG-SOT23-3



Click here to learn more:

[www.infineon.com/magnetic-position-sensors](http://www.infineon.com/magnetic-position-sensors)  
[www.infineon.com/linear-sensors](http://www.infineon.com/linear-sensors)

# Angle sensors

## Compact designs in small outline packages – at highest functional safety

**Highest variety – low end to high end, standardized and specialized in various technologies: GMR, AMR, TMR, and Hall**

Angle sensors detect the orientation of an applied magnetic field by measuring sine and cosine angle components with monolithically integrated magnetoresistive elements. Infineon offers a large variety of high-precision angle sensors in all common technologies, such as anisotropic magnetoresistance (AMR), giant magnetoresistance (GMR), tunnel magnetoresistance (TMR), and Hall.

### Key features

- Wide product range, allowing for tailored solutions
- Analog and digital interface options
- Single and dual-chip variants available
- Products specifically designed for safety-relevant applications

### Automotive applications

- Electric power steering
- Braking
- BLDC motor control
- Rotational position measurement (e.g., windscreen wiper, valves, flaps, pedals, etc.)

### Industrial/consumer applications

- BLDC motor control
- Robotics
- Servo drives
- Industrial automation
- High-end drones

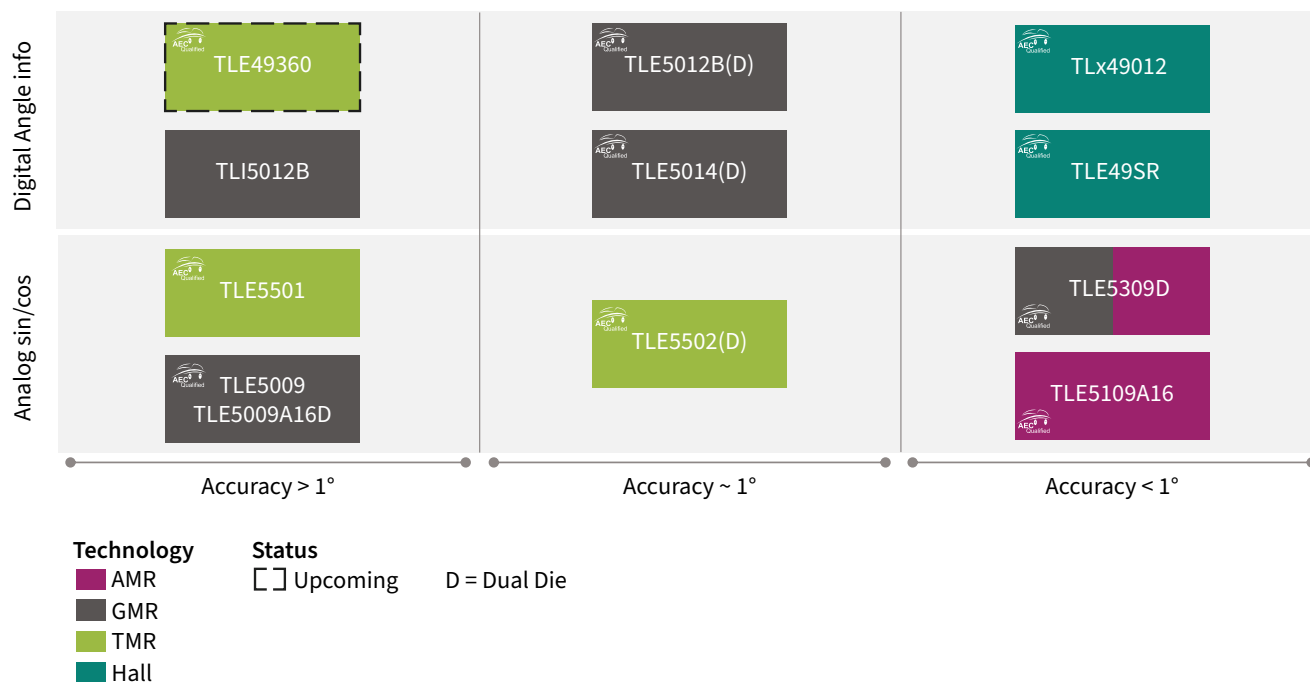

Click here to learn more:

[www.infineon.com/magnetic-position-sensors](http://www.infineon.com/magnetic-position-sensors)  
[www.infineon.com/angle-sensors](http://www.infineon.com/angle-sensors)

\*Coming soon

## XENSIV™ TLx49012 angle sensor

High accuracy, low latency, and a built-in self-calibration feature improve motor communication control

### Features

- 360° angle measurement range with <math><0.8^\circ</math> angle error and up to 16 bit resolution
- Low latency to support speeds up to 30000 rpm and accelerations up to 25000 rad/s<sup>2</sup>
- End-of-Shaft and Out-of-Shaft support

### Target applications

- Humanoid robot
- Mobile robot
- Dexterous hand
- Servo Motors
- High-end drones
- High-end gimbals



## GMR-, AMR-, and TMR-based angle sensors

Product	Technology	Die configuration	Sin/cos output	Angle output	Second interface	Accuracy	Classification	Package
TLE5009	GMR	Single die	Analog sin/cos	–	–	0.9°	ISO 26262-ready	DSO-8
TLE5009A16D	GMR	Dual die	Analog sin/cos	–	–	0.9°	ISO 26262-ready	TDSO-16
TLI5012B	GMR	Single die	SSC (SPI)	SSC (SPI)	PWM/IIF/SPC/HSM	1.9°	JESD47	DSO-8
TLE5012BD	GMR	Single & dual die	SSC (SPI)	SSC (SPI)	PWM/IIF/SPC/HSM	1.0°	ISO 26262-ready	DSO-8/ TDSO-16
TLI49012*	HALL	Single die	SPI	–	BZ/UVW/PWM	0.8°	JESD47	VSON-8
TLE5014C16(D)	GMR	Single & dual die	–	SPC	–	1.0°	ISO 26262-compliant	TDSO-16
TLE5014P16(D)	GMR	Single & dual die	–	PWM	–	1.0°	ISO 26262-compliant	TDSO-16
TLE5014S16(D)	GMR	Single & dual die	–	SENT	–	1.0°	ISO 26262-compliant	TDSO-16
TLE5014SP16(D)	GMR	Single & dual die	–	SPI	–	1.0°	QM ISO 26262-compliant	TDSO-16
TLE5109A16D	AMR	Single	Analog sin/cos	–	–	0.5°	ISO 26262-ready	TDSO-16
TLE5309D	AMR + GMR	Dual die	Analog sin/cos	–	–	AMR 0.5°, GMR 0.9°	ISO 26262-ready	TDSO-16
TLE5501	TMR	Single die	Analog sin/cos	–	–	1.0°	QM ISO 26262-compliant	DSO-8
TLE5502(D)	TMR	Single & dual die	Analog sin/cos	–	–	0.8°	ISO 26262-compliant	QFN-16

SPI = Serial peripheral interface  
IIF = Incremental interface  
PWM = Pulse width modulation

HSM = Hall switch mode  
SENT = Single edge nibble transmission

SPC = Short PWM code  
SSC = Synchronous serial communication



ISO 26262  
ready



ISO 26262  
compliant



Click here to learn more:

[www.infineon.com/magnetic-position-sensors](http://www.infineon.com/magnetic-position-sensors)  
[www.infineon.com/angle-sensors](http://www.infineon.com/angle-sensors)

# TMR-based angle sensors

Tunneling magnetoresistance (TMR) technology offers high sensing sensitivity with a high output voltage, reducing the need for an internal amplifier. Thus, the sensor can be connected directly to the microcontroller without any further amplification.

In addition, TMR technology shows a very low temperature drift, reducing external calibration and compensation efforts. The TMR technology is also well known for its low current consumption.



## TLE5501

Infineon's TMR sensor TLE5501 is available in two versions.

### TLE5501 – product versions with different pin out:

- TLE5501 E0001: pin-compatible to TLE5009 automotive qualified acc. AEC-Q100
- TLE5001 E0002: decoupled bridges for redundant external angle calculation and highest diagnostic coverage, realizing ISO 26262-compliant development ASIL D

### Features

- Large output signals of up to 0.37 V/V for direct microcontroller connection
- Discrete bridge with differential sine and cosine output
- Very low supply current: ~2 mA
- Magnetic field range (20–100 mT)
- Typ. angle error ~ 1.0° (over temperature and lifetime)
- DSO-8 package
- AEC-Q100, grade 0:  $T_A = -40^{\circ}\text{C}$  to  $+150^{\circ}\text{C}$  (ambient temperature)
- For TLE5501 E0002:
  - Reaching ASIL D with just one single sensor chip
  - ISO 26262-compliant development ASIL D

## TLE5502D

Infineon's latest and improved TMR sensor generation

### TLE5502 – product versions with different pin out:

- TLE5502D S0002: de-coupled P/N-bridges for redundant external angle calculation and highest diagnostic coverage
- TLE5502D S0003: SIN/COS bridge design



### Features

- Up to 4x ASIL-D (ISO 26262) sensors in one package enabling fail operational designs
- Improved accuracy (0.8° over lifetime and temperature)
- Compact QFN-16 package (3x3 mm)

### Applications

- Steering angle sensor
- BLDC motor commutation (e.g., wipers, pumps and actuators)
- Angular position sensing for e.g., robotics or gimbal
- Electric motors
- Industrial automation
- Safety applications



Click here to learn more:

[www.infineon.com/magnetic-position-sensors](http://www.infineon.com/magnetic-position-sensors)  
[www.infineon.com/angle-sensors](http://www.infineon.com/angle-sensors)



ISO 26262  
compliant

# GMR-based angle sensors

## TLE5014(D)

### XENSIV™ digital GMR sensor with an easy-to-use plug-and-play concept for highest functional safety applications

All XENSIV™ TLE5014 angle sensors are available as single- and dual-die products. They are easy to use and come pre-configured and pre-calibrated as plug-and-play sensors. Customers can choose between SENT, PWM, SPC, and SPI interfaces. On top of those protocol options, the sensors can be adapted to any application setup via their programmable EEPROM interfaces. TLE5014 magnetic angle sensors meet ISO 26262 ASIL C for the single die and ISO 26262 ASIL D for the dual die versions.

All products are ready for applications with the highest functional safety requirements. The sensors show an extremely small angle error of less than 1° across the entire temperature profile and lifetime. This is particularly helpful in applications requiring very accurate position sensing, such as steering angle sensing or motor commutation. Further application areas range from rotor position measurement to electric power steering (EPS), pedal position, and any other kind of position measurement.

#### Features

- Easy-to-use, plug-and-play sensors, pre-configured and pre-calibrated
- Offering high flexibility:
  - Available as single- and dual-die products
  - 12-bit digital interface with protocol options PWM, SENT, SPC, and SPI
  - EEPROM and look-up table for customer configuration and calibration
- High angle accuracy: max. 1.0° over temperature and lifetime
- High voltage capability up to 26 V
- Development fully compliant with ISO 26262
  - Developed according to ASIL D level
  - Dual die sensors reaching ASIL D, single die sensors ASIL C metrics
- Safety manual and safety analysis summary report available on request

#### Applications

- Steering angle sensing (SAS)
- Motor commutation
- Rotor position measurement
- Pedal position
- Safety applications
- Any other kind of high-accuracy position measurement

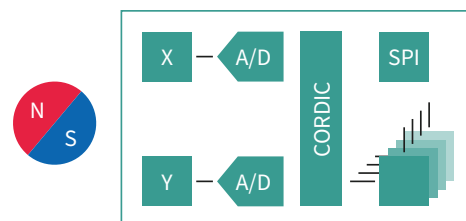

Click here to learn more:

[www.infineon.com/magnetic-position-sensors](http://www.infineon.com/magnetic-position-sensors)  
[www.infineon.com/angle-sensors](http://www.infineon.com/angle-sensors)

## TLE5012B(D), TLI5012B

### XENSIV™ GMR-based angle sensor with integrated angle calculation and multiple interfaces

#### Features

- Integrated angle calculation with CORDIC algorithm
- 15-bit representation of calculated angle value
- High update rate up to 43  $\mu$ s (23 kHz)
- Range of selectable interfaces
- SPI compatible Synchronous Serial Communication (SSC)
- Bidirectional communication up to 8 Mbps
- Pulse width modulation (PWM)
- Hall switch mode (HSM) for motor commutation
- Incremental Interface (IIF)
- Temperature compensation and auto-calibration algorithm
- Diagnostic function for sensor elements and circuitry with PRO-SIL™ support
- Dual die SMD package (redundancy)
- ISO 26262-ready
- Available as single- and dual-die
- Industrial version TLI5012B in line with JEDEC JESD47

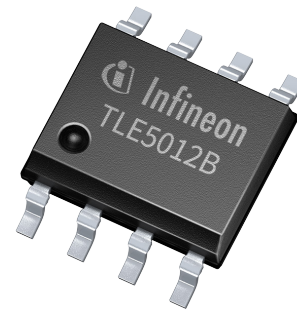

#### Applications

- Steering angle
- Brushless DC motor commutation, i.e., electric power steering (EPS)
- Rotary switches
- General angular sensing
- Incremental or absolute magnetic encoders
- Gimbals, drones, robots

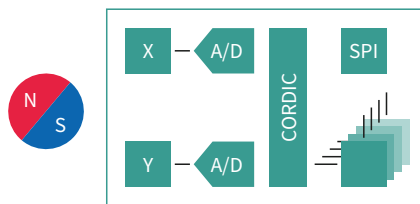

## AMR-based angle sensors

### TLE5109A16(D)

#### XENSIV™ analog AMR-based angle sensor with temperature compensation

#### Features

- Features a differential or single-ended analog interface for sine and cosine values
- Internal temperature drift compensation for gain and offset
- ISO 26262-ready

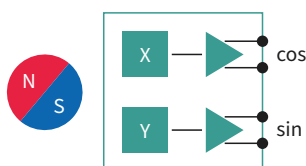

Click here to learn more:

[www.infineon.com/magnetic-position-sensors](http://www.infineon.com/magnetic-position-sensors)  
[www.infineon.com/angle-sensors](http://www.infineon.com/angle-sensors)

# Combined AMR- and GMR-based angle sensors

## TLE5309D

### XENSIV™ dual angle sensor combining AMR and GMR technologies

The TLE5309D is a diverse redundant angle sensor with analog outputs. It combines a giant magnetoresistance (GMR) sensor for a full 360° angle range with an anisotropic magnetoresistance (AMR) sensor for high precision in a flipped configuration in one package. Magnetoresistive (MR) elements measure a rotating magnetic field's sine and cosine angle components. The sensors provide analog sine and cosine output voltages that describe the magnetic angle from 0 to 180° (AMR sensor) and 0 to 360° (GMR sensor), respectively.

#### Features

- Separate supply pins for AMR and GMR sensors
- Diverse redundant design with one GMR sensor (top die) and one AMR sensor (bottom die) in one package
- Low current consumption and very fast start up
- 360° contactless angle measurement
- Immune to air gap variations due to MR-based sensing principle
- Operating ambient temperature:
  - 40°C to +125°C/-40°C to +150°C (TLE5309DHT)

#### Applications

The TLE5309D angle sensor is designed for angular position sensing in safety-critical automotive applications. Its high accuracy, 360° measurement range, and short propagation delay make it suitable for systems with high speeds and high accuracy demands, such as brushless DC (BLDC) motors for actuators and electric power steering systems (EPS). At the same time, its fast start-up time and low overall

The differential MR bridge signals are independent of the magnetic field strength, and the analog output is designed for differential or single-ended applications.

The output voltages are designed to use the dynamic range of an A/D-converter using the same supply as the sensor as a voltage reference. Both sensor ICs are supplied independently by separate supply and ground pins.



power consumption enable the device to be employed for low-power turn counting. Extremely low power consumption can be achieved with power cycling, where the advantage of fast power-on time reduces the average power consumption.

- BLDC motors for electric power steering (EPS)
- Low-power turn counter

#### Diagnostic functions in combination with AMR and GMR diversity supports ASIL D applications

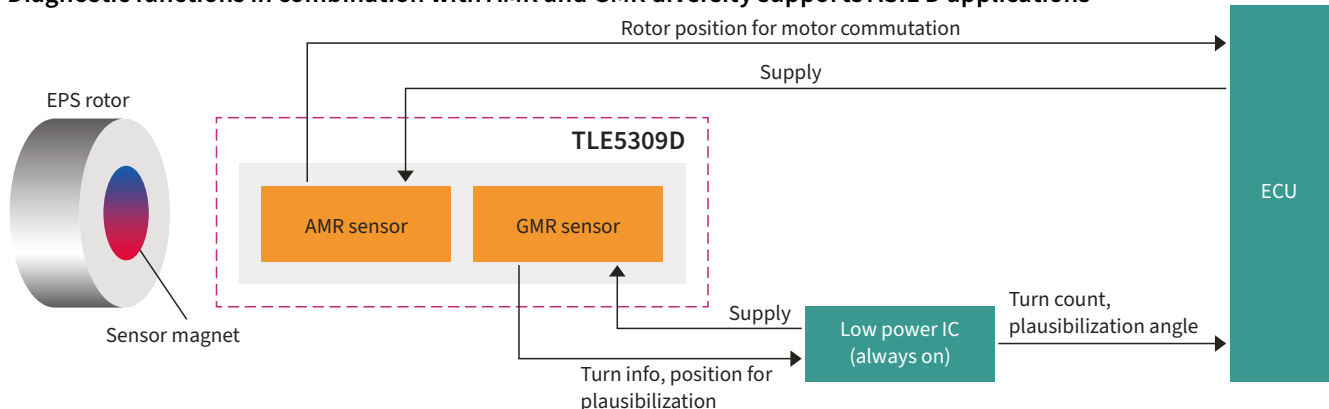

Click here to learn more:

[www.infineon.com/magnetic-position-sensors](http://www.infineon.com/magnetic-position-sensors)

[www.infineon.com/angle-sensors](http://www.infineon.com/angle-sensors)

# Stray field robust angle sensors

## Outstanding stray field robustness, high accuracy, and flexibility

The TLE49SRx family of angle sensors is a range of high-performance, stray field-robust sensors designed for use in demanding automotive applications. With their advanced measurement capabilities and compliance with key safety and electromagnetic compatibility standards, these sensors offer a reliable and versatile solution for a wide range of applications.

The increasing electrification of vehicles, including integrating electric main drives, has led to a growing concern about electromagnetic interference (EMI) caused by stray fields. These stray fields can potentially disrupt the functioning of electronic subsystems. The TLE49SRx family of angle sensors has been developed to address this issue. It features spatially separated Hall cells that enable robust magnetic field measurement, even in the presence of inhomogeneous stray fields, exceeding the requirements of EMC standards ISO 11452-1:2015.

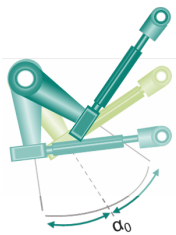

**Chassis height leveling**  
e.g., TLE49SRI3

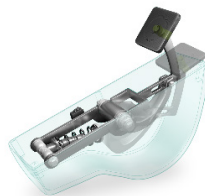

**Chassis pedal**  
e.g. TLE49SRS3

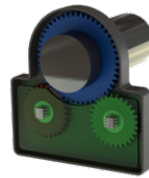

**Steering angle sensor (SAS)**  
e.g., 2 x TLE49SRC8(D)

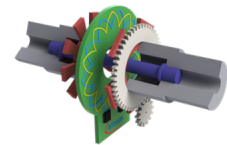

**Steering torque angle sensor (TAS)**  
e.g., (TLE4801-iTAS)+  
TLE49SRC8(D)

The TLE49SRx family is designed for various automotive applications, including chassis height, pedal position, and steering angle sensors. Several derivatives of the TLE49SR sensor are available, offering a range of package options, including a package with long leads and integrated capacitors for easy use in remote sensor applications and surface-mounted packages, as well as various communication interfaces.

These sensors have been developed in accordance with the ISO 26262 standard, meeting the ASIL C (D) metric on chip level as a safety element out of context.



**Click here to learn more:**

[www.infineon.com/magnetic-position-sensors](http://www.infineon.com/magnetic-position-sensors)

[www.infineon.com/angle-sensors](http://www.infineon.com/angle-sensors)

# TLE49SR – Stray field robust angle sensors

## Outstanding stray field robustness, high accuracy, and flexibility

The XENSIV™ TLE49SR magnetic angle sensor family is designed to meet the demands of high-performance applications. It offers excellent stray field robustness up to 8 mT in homogeneous stray fields and complies with EMC standards ISO 11452-1:2015.

The TLE49SR sensors are available in various configurations to suit different application needs. For on-PCB usage, the 8-pin surface-mounted device (SMD) package is available with PWM (TLE49SRP8), SENT (TLE49SRS8), or SPC (TLE49SRC8) communication interfaces. A dual-channel version is also available to support redundancy requirements. For remote sensor applications, derivatives are available in a 3-pin package with long leads, offering PWM (TLE49SRP3), SENT (TLE49SRS3), or SPC (TLE49SRC3) options.

All members of the XENSIV™ TLE49SR magnetic sensor family are developed in compliance with ISO26262 and support the ASIL C metric on the device level, enabling the development of fail-safe systems.

### Block diagram

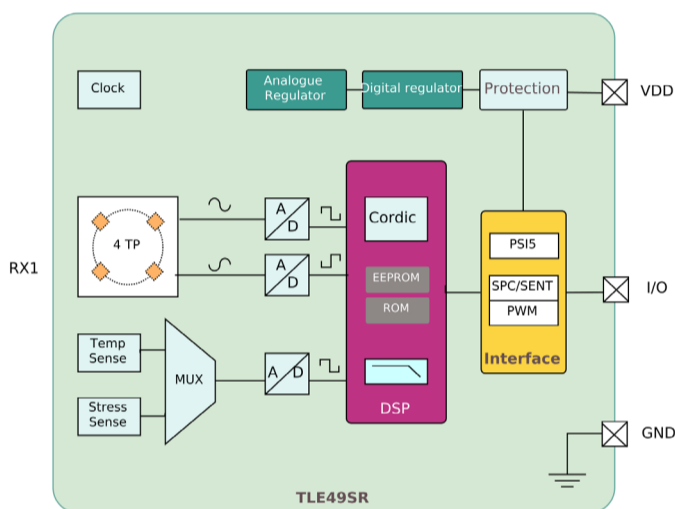

The TLE49SR integrated circuit (IC) features a comprehensive set of on-chip components, including spatially separated Hall-, temperature-, stress sensors, a signal conditioning circuit, analog-to-digital converters, and a digital signal processor. The IC also includes a clock, voltage regulators and internal protection circuitry to ensure safe and reliable operations.

The TLE49SR family offers a range of digital output interfaces, providing flexibility and compatibility with various systems. These interfaces include PSi5, SENT, SPC, and PWM, allowing for seamless integration into a variety of applications.

### Features and benefits

Key features
– Stray field Immunity, exceeding ISO 11452-1:2015
– Excellent angle performance with very low jitter and fast response time
– Very low jitter delay $\pm 1 \mu\text{s}$ and very fast response time $9.8 \mu\text{s} \sim 26 \text{ms}$
– EEPROM for customized configuration and customer specific ID
– PSi5 protocol V1.3 and V2.3, PWM, SENT, and SPC Interface
– ISO 26262-compliant, ASIL C(D), and ASIL D rating

Key benefits
– High system reliability eliminates the need for external shielding
– Look-up table for correction of systematic angle errors, angle error $<0.5^\circ$
– Enables for highly responsive and fast systems
– Easy design with high product flexibility
– Synchronization pulse for PSi5-, frame holder mechanism for SPC-sensors
– Dual die version for redundant, ASIL D compliant systems

### Product overview

Product	Description	Package	ISO26262 (Functional safety)	ISO 11452-8:2015 (Stray field robust)	Ordering code
TLE49SRI3	Leaded 3-pin package, with 2 internal capacitors, PSi5 Interface	SSO-3	ASIL C	Yes	SP005398935
TLE49SRC3	Leaded 3-pin package, with 3 internal capacitors, SPC Interface	SSO-3	ASIL C	Yes	SP005398941
TLE49SRS3	Leaded 3-pin package, with 3 internal capacitors, SENT Interface	SSO-3	ASIL C	Yes	SP005398939
TLE49SRP3	Leaded 3-pin package, with 3 internal capacitors, PWM Interface	SSO-3	ASIL C	Yes	SP005398937
TLE49SRC8	8-pin SMD package, SPC Interface	TDSO-8	ASIL C	Yes	SP005398933
TLE49SRS8	8-pin SMD package, SENT Interface	TDSO-8	ASIL C	Yes	SP005398931
TLE49SRP8	8-pin SMD package, PWM Interface	TDSO-8	ASIL C	Yes	SP005398929
TLE49SRC8D	8-pin SMD package, dual die, SPC Interface	TDSO-8	ASIL D	Yes	SP005859106
TLE49SRS8D	8-pin SMD package, dual die, SENT Interface	TDSO-8	ASIL D	Yes	SP005948428



Click here to learn more:

[www.infineon.com/magnetic-position-sensors](http://www.infineon.com/magnetic-position-sensors)  
[www.infineon.com/angle-sensors](http://www.infineon.com/angle-sensors)

# Shield2Go

## Infineon's Shield2Go boards offer a unique customer and evaluation experience

The boards are equipped with one Infineon IC and a ready-to-use Arduino library. Customers can now develop their own system solutions by combining

Sensor2Go boards together with Infineon MyIoT adapters. MyIoT adapters are gateways to external hardware solutions like Arduino and Raspberry Pi, popular IoT hardware platforms. All this enables the fastest evaluation and development of the IoT system.

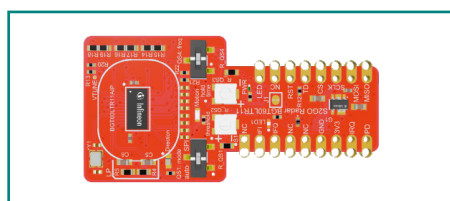

**Product name:** BGT60LTR11AIP Radar Shield2Go  
**Sales name:** S2GO RADAR BGT60LTR11  
**Ordering code:** SP005594890

Product information

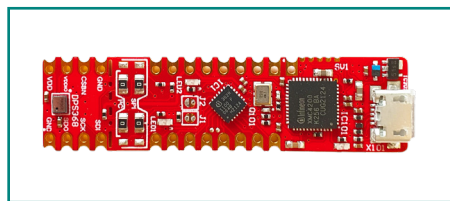

**Product name:** DPS368 pressure sensor Shield2Go  
**Sales name:** KIT\_DPS368\_2GO  
**Ordering code:** SP005729572

Product information

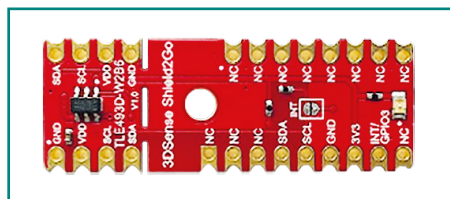

**Product name:** TLE493DW2B6 3D Sense Shield2Go  
**Sales name:** S2GO\_3D\_TLE493DW2B6-A0  
**Ordering code:** SP004308594

Product information

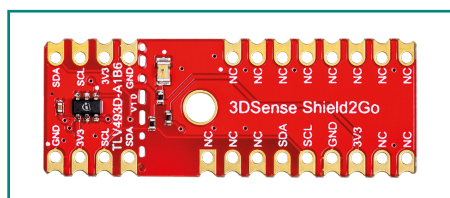

**Product name:** TLV493D 3D Sense Shield2Go  
**Sales name:** S2GO\_3D-SENSE\_TLV493D  
**Ordering code:** SP001823678

Product information

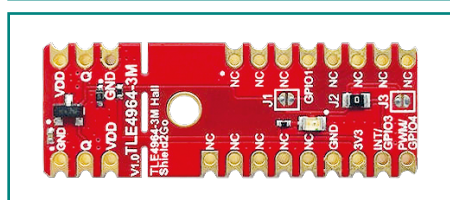

**Product name:** TLE4964-3M Hall Sense Shield2Go  
**Sales name:** S2GO\_HALL\_TLE4964-3M  
**Ordering code:** SP004308590

Product information

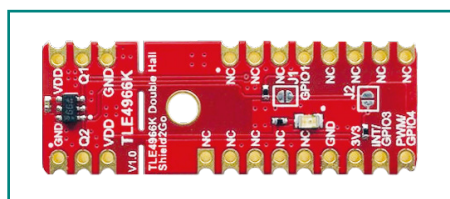

**Product name:** TLE4966K Double Hall Sense Shield2Go  
**Sales name:** S2GO\_2\_HALL\_TLE4966K  
**Ordering code:** SP004308598

Product information



Click here to learn more:

[www.infineon.com/magnetic-position-sensors](http://www.infineon.com/magnetic-position-sensors)  
[www.infineon.com/pressure-sensors](http://www.infineon.com/pressure-sensors)

[www.infineon.com/current-sensors](http://www.infineon.com/current-sensors)  
[www.infineon.com/mems-microphones](http://www.infineon.com/mems-microphones)

[www.infineon.com/gas-sensors](http://www.infineon.com/gas-sensors)  
[www.infineon.com/radar-sensors](http://www.infineon.com/radar-sensors)

# Shield2Go

## Microcontroller

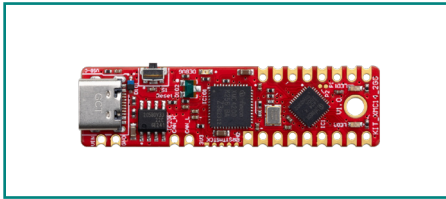

**Product name:** XMC1400 2Go kit  
**Sales name:** KIT\_XMC14\_2GO  
**Ordering code:** SP006065576

Product information

## MyIoT Adapter

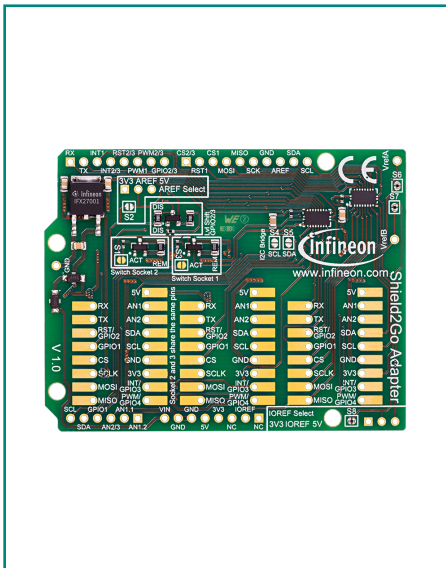

**Product name:** MyIoT Adapter  
**Sales name:** MY IOT ADAPTER  
**Ordering code:** SP002434972

Infineon's Shield2Go boards offer a unique customer and evaluation experience – the boards are equipped with one Infineon IC and a ready-to-use Arduino library. Customers can now develop their own system solutions by combining Shield2Go boards with Infineon MyIoT adapters. MyIoT adapters are gateways to external hardware solutions like Arduino and Raspberry Pi, popular IoT hardware platforms. This enables the fastest evaluation and development of IoT systems.

Product information

## XENSIV™ Sensor Shield



**Product name:** XENSIV™ Sensor Shield  
**Sales name:** SHIELD\_XENSIV\_A  
**Ordering code:** SP006018677

Infineon's XENSIV™ Sensor Shield provides seamless hardware compatibility between sensors, microcontrollers, and connectivity products. When paired with an MCU / Wi-Fi baseboard via the Arduino UNO interface, the board enables developers to quickly evaluate and develop with environmental sensors like:

- 60 GHz radars
- PDM microphones
- Pressure sensors
- Six-axis IMU
- Three-axis magnetometer
- Temperature and humidity

The shield also features a TFT display (80x160), and OPTIGA™ Trust-M secure element, and a QWIIC connector for additional peripheral expandability.

Product information

[Click here to learn more:](#)

[www.infineon.com/magnetic-position-sensors](http://www.infineon.com/magnetic-position-sensors)  
[www.infineon.com/pressure-sensors](http://www.infineon.com/pressure-sensors)

[www.infineon.com/current-sensors](http://www.infineon.com/current-sensors)  
[www.infineon.com/mems-microphones](http://www.infineon.com/mems-microphones)

[www.infineon.com/gas-sensors](http://www.infineon.com/gas-sensors)  
[www.infineon.com/radar-sensors](http://www.infineon.com/radar-sensors)

# Sensor2Go kits

## Affordable plug-and-play development boards

Sensor2Go kits come equipped with advanced sensors and an integrated Arm® Cortex®-M0 CPU, making them the perfect choice for developers and hobbyists. These kits include a complete set of on-board devices, such as an on-board debugger, allowing you to quickly build and customize your own applications and gadgets.

<p><b>Absolute Pressure (MAP and BAP) Sensor2Go kits</b></p> <p><b>Product name:</b>            KP215F1701-PS2GO-KIT            KP229E3518-PS2GO-KIT            KP236-PS2GO-KIT            KP254-PS2GO-KIT            KP276-PS2GO-KIT</p> <p><b>Ordering code:</b>            SP002676652            SP002676656            SP002676664            SP002676664            SP005910372</p>	<p>Product information</p> 
<p><b>Magnetic 3D Sensor2Go kits</b></p> <p><b>Product name:</b>            TLE493D-W2B6 MS2GO            TLV493D-A1B6 MS2GO</p> <p><b>Ordering code:</b>            SP001707578            SP001707574</p>	<p>Product information</p> 
<p><b>Magnetic angle Sensor2Go kits</b></p> <p><b>Product name:</b>            TLE5012B_E1000_MS2GO            TLI5012B_E1000_MS2GO            TLE5012B_E5000_MS2GO            TLE5012B_E9000_MS2GO</p> <p><b>Ordering code:</b>            SP002133956            SP002133960            SP002133964            SP002133968</p>	<p>Product information</p> 
<p><b>Current Sensor2Go kits</b></p> <p><b>Product name:</b>            TLI4971_MS2GO            TLE4973_MS2GO</p> <p><b>Ordering code:</b>            SP005345474            SP006039680</p>	<p>Product information</p> 
<p><b>Magnetic speed Sensor2Go kits</b></p> <p><b>Product name:</b>            TLE4922 MS2GO</p> <p><b>Ordering code:</b>            SP003029974</p>	<p>Product information</p> 
<p><b>Magnetic switches Sensor2Go kits</b></p> <p><b>Product name:</b>            TLE4966_MS2GO</p> <p><b>Ordering code:</b>            SP005406992</p>	<p>Product information</p> 















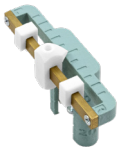

Click here to learn more:

[www.infineon.com/magnetic-position-sensors](http://www.infineon.com/magnetic-position-sensors)  
[www.infineon.com/pressure-sensors](http://www.infineon.com/pressure-sensors)

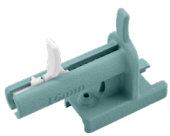
[www.infineon.com/current-sensors](http://www.infineon.com/current-sensors)  
[www.infineon.com/mems-microphones](http://www.infineon.com/mems-microphones)

[www.infineon.com/gas-sensors](http://www.infineon.com/gas-sensors)  
[www.infineon.com/radar-sensors](http://www.infineon.com/radar-sensors)

# Add ons for Sensor2Go kits and Shield2Go

	<p><b>Joystick for all 3D magnetic Sensor2Go kits and Shield2Go</b>  <b>Product name:</b> JOYSTICK FOR 3D 2 GO KIT  <b>Ordering code:</b> SP001491834</p>	<p>Product information</p> 
	<p><b>Rotate knob for all 3D magnetic Sensor2Go kits, angle Sensor2Go kits and 3D magnetic sensor Shield2Go</b>  <b>Product name:</b> ROTATE KNOB 3D 2 GO KIT  <b>Ordering code:</b> SP001504602</p>	<p>Product information</p> 
	<p><b>Linear slider for all 3D magnetic Sensor2Go kits and Shield2Go</b>  <b>Product name:</b> LINEAR-SLIDER 2GO  <b>Ordering code:</b> SP002043034</p>	<p>Product information</p> 
	<p><b>Out of shaft adapter for all 3D magnetic Sensor2Go kits and Shield2Go</b>  <b>Product name:</b> OUT OF SHAFT FOR 3D 2 GO  <b>Ordering code:</b> SP003475178</p>	<p>Product information</p> 
	<p><b>Linear control trigger for all 3D magnetic Sensor2Go kits and Shield2Go</b>  <b>Product name:</b> POWER_DRILL2GO  <b>Ordering code:</b> SP005350194</p>	<p>Product information</p> 
	<p><b>Human machine interface (HMI) direction indicator for all 3D magnetic Sensor2Go kits and Shield2Go</b>  <b>Product name:</b> DIR_INDICATOR2GO  <b>Ordering code:</b> SP005350196</p>	<p>Product information</p> 
	<p><b>HMI mini control with 4 directions and 360° rotation for all 3D magnetic Sensor2Go kits and Shield2Go</b>  <b>Product name:</b> MINI_CONTROL2GO  <b>Ordering code:</b> SP005350192</p>	<p>Product information</p> 



Click here to learn more:

[www.infineon.com/magnetic-position-sensors](http://www.infineon.com/magnetic-position-sensors)  
[www.infineon.com/pressure-sensors](http://www.infineon.com/pressure-sensors)

[www.infineon.com/current-sensors](http://www.infineon.com/current-sensors)  
[www.infineon.com/mems-microphones](http://www.infineon.com/mems-microphones)

[www.infineon.com/gas-sensors](http://www.infineon.com/gas-sensors)  
[www.infineon.com/radar-sensors](http://www.infineon.com/radar-sensors)

# Add ons for Sensor2Go kits and Shield2Go

	<p><b>OpenClose adapter for Hall switch Shield2Go</b>  <b>Product name:</b> OPENCLOSE2GOHS  <b>Ordering code:</b> SP005544849</p>	<p>Product information</p> 
	<p><b>Play2Go for 3D magnetic sensor</b>  <b>Product name:</b> 3D PLAY2GO KIT  <b>Ordering code:</b> SP005731811</p>	<p>Product information</p> 
	<p><b>Contactless switch array for all 3D magnetic Sensor2Go kits and Shield2Go</b>  <b>Product name:</b> Contactless switch array  <b>Ordering code:</b>  Simply use our 3D printing files, link to, and start your 3D print.</p>	<p>Product information</p> 
	<p><b>Spindle2Go for all 3D magnetic sensor Shield2Go</b>  <b>Product name:</b> SPINDLE2GO  <b>Ordering code:</b> SP005989689</p>	<p>Product information</p> 
	<p><b>Drill Trigger V2 for all 3D magnetic Sensor2Go kits</b>  <b>Product name:</b> DRILL TRIGGER V2  <b>Ordering code:</b> SP006066136</p>	<p>Product information</p> 



Click here to learn more:

[www.infineon.com/magnetic-position-sensors](http://www.infineon.com/magnetic-position-sensors)  
[www.infineon.com/pressure-sensors](http://www.infineon.com/pressure-sensors)

[www.infineon.com/current-sensors](http://www.infineon.com/current-sensors)  
[www.infineon.com/mems-microphones](http://www.infineon.com/mems-microphones)

[www.infineon.com/gas-sensors](http://www.infineon.com/gas-sensors)  
[www.infineon.com/radar-sensors](http://www.infineon.com/radar-sensors)

# Evaluation boards – for simple and easy evaluation

	<p><b>MEMS microphones flex evaluation kits</b></p> <p><b>Product name:</b></p> <p><b>code:</b></p> <table border="0"> <tr><td>EVAL_IM69D120_FLEXKIT</td><td>SP002153026</td></tr> <tr><td>EVAL_IM69D130_FLEXKIT</td><td>SP002153022</td></tr> <tr><td>KIT_IM66D130MV01_FLEX</td><td>SP006038060</td></tr> <tr><td>KIT_IM66D132HV01_FLEX</td><td>SP006038061</td></tr> <tr><td>KIT_IM68A130V01_FLEX</td><td>SP005728206</td></tr> <tr><td>KIT_IM68D121JV01_FLEX</td><td>SP006155584</td></tr> <tr><td>KIT_IM68D128BV01_FLEX</td><td>SP006114517</td></tr> <tr><td>KIT_IM69D127V11_FLEX</td><td>SP005403891</td></tr> <tr><td>KIT_IM69D128SV01_FLEX</td><td>SP005744505</td></tr> <tr><td>KIT_IM69D129FV01_FLEX</td><td>SP006038667</td></tr> <tr><td>KIT_IM70A135V01_FLEX</td><td>SP005728204</td></tr> <tr><td>KIT_IM70D122V01_FLEX</td><td>SP005826638</td></tr> <tr><td>KIT_IM72D128V01_FLEX</td><td>SP005429924</td></tr> <tr><td>KIT_IM72D128VV01_FLEX</td><td>SP006038668</td></tr> <tr><td>KIT_IM73A135V01_FLEX</td><td>SP005415695</td></tr> </table>	EVAL_IM69D120_FLEXKIT	SP002153026	EVAL_IM69D130_FLEXKIT	SP002153022	KIT_IM66D130MV01_FLEX	SP006038060	KIT_IM66D132HV01_FLEX	SP006038061	KIT_IM68A130V01_FLEX	SP005728206	KIT_IM68D121JV01_FLEX	SP006155584	KIT_IM68D128BV01_FLEX	SP006114517	KIT_IM69D127V11_FLEX	SP005403891	KIT_IM69D128SV01_FLEX	SP005744505	KIT_IM69D129FV01_FLEX	SP006038667	KIT_IM70A135V01_FLEX	SP005728204	KIT_IM70D122V01_FLEX	SP005826638	KIT_IM72D128V01_FLEX	SP005429924	KIT_IM72D128VV01_FLEX	SP006038668	KIT_IM73A135V01_FLEX	SP005415695	<p>Product information</p> 
EVAL_IM69D120_FLEXKIT	SP002153026																															
EVAL_IM69D130_FLEXKIT	SP002153022																															
KIT_IM66D130MV01_FLEX	SP006038060																															
KIT_IM66D132HV01_FLEX	SP006038061																															
KIT_IM68A130V01_FLEX	SP005728206																															
KIT_IM68D121JV01_FLEX	SP006155584																															
KIT_IM68D128BV01_FLEX	SP006114517																															
KIT_IM69D127V11_FLEX	SP005403891																															
KIT_IM69D128SV01_FLEX	SP005744505																															
KIT_IM69D129FV01_FLEX	SP006038667																															
KIT_IM70A135V01_FLEX	SP005728204																															
KIT_IM70D122V01_FLEX	SP005826638																															
KIT_IM72D128V01_FLEX	SP005429924																															
KIT_IM72D128VV01_FLEX	SP006038668																															
KIT_IM73A135V01_FLEX	SP005415695																															
<p><b>MEMS microphones Audiohub Nano boards</b></p> <p><b>Product name:</b></p> <p>EVAL AHNB DIGITALV01</p> <p>EVAL AHNB ANALOGV01</p>	<p><b>Ordering code:</b></p> <p>SP005955184</p> <p>SP005568087</p>	<p>Product information</p> 																														
<p><b>Current sensors evaluation boards</b></p> <p><b>Product name:</b></p> <p>TLE4973 EVAL 120A</p> <p>TLE4973 EVAL INLAY</p> <p>TLE4973 EVAL STD PCB</p> <p>TLE4973 EVAL VER BAR</p> <p>TLE4973 EVAL LAT BAR</p> <p>TLE4972 EVAL LAT BAR</p> <p>TLE4972 EVAL STD PCB</p> <p>TLE4972 EVAL INLAY</p> <p>TLI4971 EVAL 120A</p> <p>TLE4971 EVAL 120A</p>	<p><b>Ordering code:</b></p> <p>SP006015313</p> <p>SP005853842</p> <p>SP005853840</p> <p>SP005853847</p> <p>SP005853844</p> <p>SP005632140</p> <p>SP005632136</p> <p>SP005632138</p> <p>SP005876845</p> <p>SP005343588</p>	<p>Product information</p> 																														
<p><b>Linear sensors evaluation boards</b></p> <p><b>Product name:</b></p> <p>TLI5590 SATELLITE</p> <p>TLI5590 EVAL KIT</p>	<p><b>Ordering code:</b></p> <p>SP005857647</p> <p>SP005857645</p>	<p>Product information</p> 																														
	<p><b>Magnetic position sensors evaluation boards</b></p> <p><b>Product name:</b> GAME CONTROLLER</p> <p><b>Ordering code:</b> SP006056290</p>	<p>Product information</p> 																														
<p><b>Position sensors evaluation boards</b></p> <p><b>Product name:</b></p> <p>TLI49012 EVAL KIT*</p>	<p><b>Ordering code:</b></p> <p>SP006227376</p>	<p>Product information</p> 																														



Click here to learn more:

[www.infineon.com/magnetic-position-sensors](http://www.infineon.com/magnetic-position-sensors)

[www.infineon.com/current-sensors](http://www.infineon.com/current-sensors)

[www.infineon.com/gas-sensors](http://www.infineon.com/gas-sensors)







[www.infineon.com/pressure-sensors](http://www.infineon.com/pressure-sensors)

[www.infineon.com/mems-microphones](http://www.infineon.com/mems-microphones)

[www.infineon.com/radar-sensors](http://www.infineon.com/radar-sensors)

## Choose the best fit magnetic sensor solution from the broadest portfolio

Our sensor simulation tools allow you to compare products in application conditions. The tools are easy-to-use and will guide you in identifying the most suitable Infineon XENSIV™ sensor combined with the best-fit magnet.

 <p>Current sensor</p>	<p><b>XENSIV™ current sensors simulation tool</b></p> <p>Define and optimize your system's current sensing structure. The tool supports the design of lateral and vertical insertions for PCB (two to ten-layer stack) or bus-bar-based applications. The simulation will provide insertion resistance, field transfer factor, sensitivity range, measurement range, and power dissipation, as well as cross-talk in a three-phase system.</p> <p><a href="#">Try it out</a></p>
 <p>3D sensor</p>	<p><b>XENSIV™ 3D sensors simulation tool</b></p> <p>3D magnetic field sensor for smaller, more accurate, and robust designs. The sensor family, with low current consumption and cost-optimized design, specifically addresses the needs of new magnetic sensor applications in consumer, industrial, and automotive. They are ideally suited for measuring three-dimensional movement within a magnetic field, linear slide movement, and 360° angle rotation.</p> <p><a href="#">Try it out</a></p>
 <p>Switches and latches</p>	<p><b>XENSIV™ switches and latches simulation tool</b></p> <p>Discover Infineon's broad energy-saving portfolio of Hall switches and latches in the smallest package. Simulate your Hall switch applications and see the results in an accurate simulation of the magnetic field and the switching behavior of the Hall switch in the application.</p> <p><a href="#">Try it out</a></p>
 <p>Angle sensor</p>	<p><b>XENSIV™ angle sensors simulation tool</b></p> <p>Highest variety - low end to high end, standardized and specialized in all four magnetic technologies: Hall, GMR, AMR, and TMR. This tool calculates the valid distance from the magnet surface to the sensor and the assembly error, given certain parameters: magnetic properties, sensor specification, and assembly tolerances.</p> <p><a href="#">Try it out</a></p>
 <p>Magnetic speed sensor</p>	<p><b>XENSIV™ magnetic speed sensors solution tool</b></p> <p>Infineon's innovative speed sensor solution tool will provide a sensor recommendation for your tooth wheel and back bias magnet geometry. The sensors are ranked according to their expected maximum air gap capability. Customer constraints like enhanced stray field immunity, the necessity for a direction channel, or the sensor interface are considered in the selection process.</p> <p><a href="#">Try it out</a></p>
 <p>Magnetic position sensors</p>	<p><b>XENSIV™ magnetic position sensors design tool</b></p> <p>Infineon's innovative design tool covers some typical applications which can be addressed with 3D, angle or linear magnetic sensors:</p> <ul style="list-style-type: none"> <li>- Angle measurement (rotational movement of the magnet)</li> <li>- Linear position measurement (linear movement of the magnet)</li> <li>- Joystick (3D movement of the magnet)</li> <li>- Additionally: stray field consideration</li> </ul> <p>The tool provides pre-defined or user-customized magnets. The tool automatically calculates the magnetic field components at the sensor location. Calculation is based on the sensor arrangement defined by the user. Mechanical mounting tolerances of the sensor and the magnet are considered.</p> <p><a href="#">Try it out</a></p>



Click here to learn more:

[www.infineon.com/magnetic-position-sensors](http://www.infineon.com/magnetic-position-sensors)

[www.infineon.com/current-sensors](http://www.infineon.com/current-sensors)

[www.infineon.com/gas-sensors](http://www.infineon.com/gas-sensors)

[www.infineon.com/pressure-sensors](http://www.infineon.com/pressure-sensors)

[www.infineon.com/mems-microphones](http://www.infineon.com/mems-microphones)

[www.infineon.com/radar-sensors](http://www.infineon.com/radar-sensors)

# ISO 26262 – Functional Safety (FuSa)

## Dependable electronics based on Functional Safety

Automotive Functional Safety – we simplify the process of integrating safety features with our safety guidelines and services.

Infineon provides dependable electronics to support today's safety-relevant systems and future fail-operational solutions, serving as essential components that allow customers to meet their safety requirements at the application level. Highly integrated systems equipped with reliable electronic semiconductors play a crucial role in key application areas like connectivity, electromobility, and advanced levels of automated driving. The ISO 26262 standard establishes requirements and provides guidance for integrating products into automotive safety applications.

### Discover Infineon's products with ISO 26262 classification

With our holistic approach to functional safety, Infineon is addressing the increased complexity and stringent requirements that make functional safety projects costly and time-consuming. We provide the necessary products, including documentation and supporting information, to ease integration and reduce efforts for system integrators.

### Benefit from:

- Innovative solutions for automotive safety-related applications
- Improved time-to-market through comprehensive safety documentation for ISO 26262-compliant products
- Reduced integrators' efforts with ISO 26262-compliant and ready-to-use products
- A broad portfolio of ISO 26262-compliant products already available
- Newly developed automotive parts that will primarily follow an ISO 26262-compliant development flow

### Safety conformity levels:

- PRO-SIL™ ISO 26262-compliant devices meet all relevant requirements for semiconductors as defined in the ISO 26262 series of standards for automotive functional safety
- The PRO-SIL™ ISO 26262-ready marking designates QM devices that can be integrated into a safety-related application by utilizing the ISO 26262:2018 Clause 8-13, Class II hardware evaluation framework
- The Infineon Automotive Ensured Compliance process framework was certified by SGS-TÜV Saar for compliance with ISO 26262:2018 as of April 2022. This certification reinforces our commitment to automotive functional safety

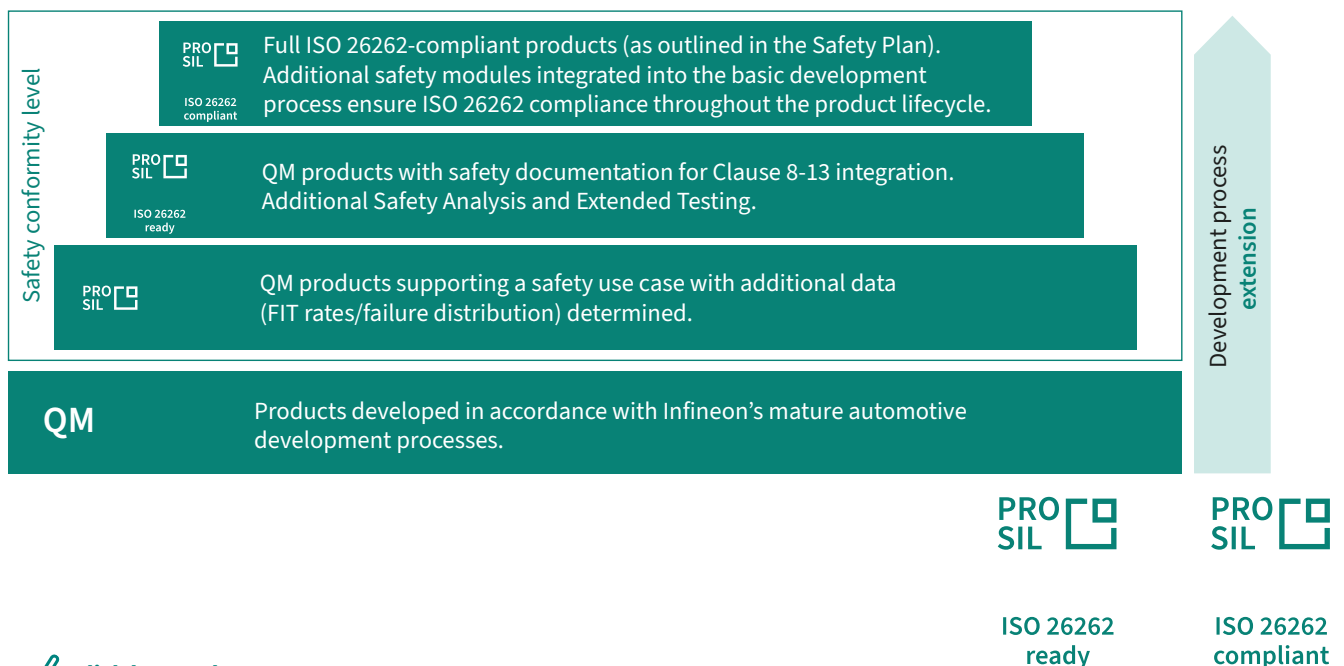

Click here to learn more:

[www.infineon.com/magnetic-position-sensors](http://www.infineon.com/magnetic-position-sensors)  
[www.infineon.com/pressure-sensors](http://www.infineon.com/pressure-sensors)

[www.infineon.com/current-sensors](http://www.infineon.com/current-sensors)  
[www.infineon.com/mems-microphones](http://www.infineon.com/mems-microphones)

[www.infineon.com/gas-sensors](http://www.infineon.com/gas-sensors)  
[www.infineon.com/radar-sensors](http://www.infineon.com/radar-sensors)

# Dependability is the key driver for the megatrend towards autonomous driving

The future car will be fully connected and always online. It will be all-electric and autonomous. At Infineon, we believe that realizing this vision requires both technology and trust.

The growing demand for safe electronic systems in vehicles that drivers and passengers can rely on lays the foundation for trust and drives progress toward higher levels of automated driving.

Earning the trust of tomorrow's passengers begins with dependable electronics that enable highly available, reliable, robust, safe, and secure systems, capable of operating in all conditions.

Infineon is your trusted partner, offering all the essential components for your dependable systems – automotive quality, functional safety, cybersecurity, innovative products, system expertise, and operational excellence.

## Dependable electronics for safer, smarter vehicles

As vehicles become increasingly reliant on electronic components, demand for safe, reliable systems continues to grow. Rising levels of automated driving especially depend on drivers' and passengers' trust in the quality and reliability of each component. The complexity and requirements in the automotive industry are expected to increase further, particularly in terms of quality and dependability, to ensure vehicles operate safely and smoothly throughout their 15-year lifespan.

Infineon's commitment to delivering high-quality, dependable products has resulted in a portfolio that offers superior performance and unmatched durability, driven by our zero-defect mentality. We go beyond industry standards to meet the real-world requirements of applications.

Enhance your automotive systems and applications with our high-quality semiconductor components designed for your needs.

## Dependable electronics based on quality

Automotive quality beyond the standards with a zero-defect mindset.

Vehicle complexity and functionality will continue to grow, driving the need for dependable electronics, with quality being one of its key ingredients. Our passion for quality creates a product portfolio that meets high standards and delivers highly reliable, robust products.

## How Infineon differentiates as a quality leader:

1. Our goal is to go beyond standards to better meet real application requirements: from intensive screening methods to detect production defects, to advanced AEC Q100/101 tests (where required), to sub-1 dpm validation aimed at achieving ultralow defect rates.
2. Our track record of achievements, including multiple quality awards from customers such as Toyota (Honor Quality Award in 2020) and Continental (Supplier of the Year in 2019), demonstrates that we consistently meet and exceed outstanding quality targets in the automotive industry.
3. Infineon offers best-in-class customer service, supported by a regional network of failure analysis labs, strong localized expertise, technical training programs, and state-of-the-art regional quality analysis labs equipped for advanced failure analysis.
4. We meet customer needs through industry-leading product requirements, design, manufacturing, and testing practices. Quality is integrated into our development processes (e.g., RDDF), design rules (e.g., ADeGo), materials, manufacturing processes, process controls, proprietary testing, and screening methods.

## Infineon's Zero Defect mentality is built upon:

- Producing 24/7/365 at sub-dpm levels: Translated into a year's timeline, this means we deliver zero defects for all but the last three seconds of the year.
- Delivering sub-ppm quality levels.
- Achieving Zero Defect status for 90 percent of our products.

We go beyond the standards to better meet real application requirements.



Click here to learn more:

[www.infineon.com/magnetic-position-sensors](http://www.infineon.com/magnetic-position-sensors)  
[www.infineon.com/pressure-sensors](http://www.infineon.com/pressure-sensors)

[www.infineon.com/current-sensors](http://www.infineon.com/current-sensors)  
[www.infineon.com/mems-microphones](http://www.infineon.com/mems-microphones)

[www.infineon.com/gas-sensors](http://www.infineon.com/gas-sensors)  
[www.infineon.com/radar-sensors](http://www.infineon.com/radar-sensors)



# Infineon support for sensors

## Useful links and helpful information

### Further information, datasheets, and documents

[www.infineon.com/xensiv](http://www.infineon.com/xensiv)

[www.infineon.com/sensors](http://www.infineon.com/sensors)

[www.infineon.com/tof-3d-image-sensors](http://www.infineon.com/tof-3d-image-sensors)

[www.infineon.com/current-sensors](http://www.infineon.com/current-sensors)

[www.infineon.com/gas-sensors](http://www.infineon.com/gas-sensors)

[www.infineon.com/h2-sensors](http://www.infineon.com/h2-sensors)

[www.infineon.com/inductive-position-sensors](http://www.infineon.com/inductive-position-sensors)

[www.infineon.com/mems-microphones](http://www.infineon.com/mems-microphones)

[www.infineon.com/pressure-sensors](http://www.infineon.com/pressure-sensors)

[www.infineon.com/radar-sensors](http://www.infineon.com/radar-sensors)

[www.infineon.com/magnetic-position-sensors](http://www.infineon.com/magnetic-position-sensors)

[www.infineon.com/3d-sensors](http://www.infineon.com/3d-sensors)

[www.infineon.com/angle-sensors](http://www.infineon.com/angle-sensors)

[www.infineon.com/linear-sensors](http://www.infineon.com/linear-sensors)

[www.infineon.com/switches-latches](http://www.infineon.com/switches-latches)



Info



Documents



Boards  
and designs



Tools



Play





# Infineon powerful support

Find an answer to your question

## About Infineon

[www.infineon.com/green](http://www.infineon.com/green)  
[www.infineon.com/quality](http://www.infineon.com/quality)

## General support

[www.infineon.com/support](http://www.infineon.com/support)  
[www.infineon.com/packages](http://www.infineon.com/packages)  
[www.infineon.com/wheretobuy](http://www.infineon.com/wheretobuy)  
[www.infineon.com/opn](http://www.infineon.com/opn)  
[www.infineon.com/academy](http://www.infineon.com/academy)

## Design Resources

[Solution finder](#)  
[Evaluation boards finder](#)  
[Simulation and modeling](#)  
[Infineon Designer](#)  
[Infineon for Makers](#)

## Connect with us

[Infineon developer community](#)  
[Facebook](#)  
[Instagram](#)  
[LinkedIn](#)  
[Youtube](#)

Subscribe to marketing communications [here](#)

Contact our technical support [here](#)



# Infineon customized solutions

## Your specific needs, realized



A customized solution (commonly known in the industry as an ASIC — Application Specific IC, or CSP — Customer Specific Product) is designed, planned, developed, and used for a specific purpose. Its mission is to be optimized and efficient, with all the required functionalities and features for a specific application for a single customer.

## Infineon as your one-stop-shop from design to delivery



Infineon, as a market leader in customized solutions, believes innovation comes through collaboration and exploring new paths. Working closely with our customers, understanding their needs, and combining their needs with our cutting-edge solutions, we know there is always a benefit for every customer and application. Whether the challenge is related to IP or BOM constraints or requires higher integration, an ASIC can be the solution. Furthermore, customers benefit from Infineon's trusted quality, supply guarantee, and experience, combined with additional advantages such as IP protection and a well-established partner network.



Click here to learn more:  
[www.infineon.com/asic](http://www.infineon.com/asic)



## A process streamlined through efficiency, expertise, and experience

The journey starts with you and a focus on feasibility – we match your needs early on with our 40 years of expertise in building world-class, industry-leading semiconductors and ensure the successful implementation of your requirements.

## From technology advantage to supply stability

Whether it is digital, analog, or mixed-signal devices, an embedded processor, or integrated sensors, we have the experience and product know-how. Being one of the largest semiconductor companies, we also have a vast array of IPs. We can integrate almost anything into your chip from our wide variety of sensors, discrete devices, drivers, and many more, including support for higher voltage levels. Our in-house fabrication facilities and design centers around the globe are known for the highest quality standards. We also have well-established partnerships with all major silicon foundries and assembly test fabs to complement our in-house technologies. At every step along the way, we take pride in the highest quality Infineon is known for.

If you are interested and would like to find out further information, visit [www.infineon.com/asic](http://www.infineon.com/asic)

14 locations<sup>1</sup>

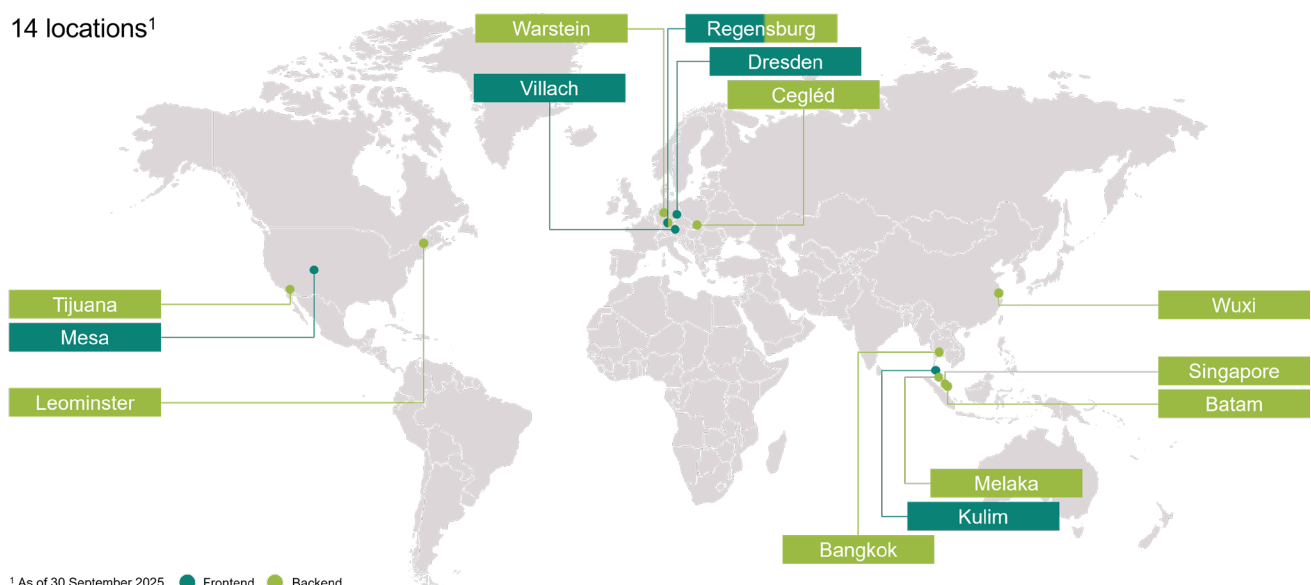

<sup>1</sup> As of 30 September 2025 ● Frontend ● Backend



Click here to learn more:  
[www.infineon.com/asic](http://www.infineon.com/asic)



# The Infineon Partner Program



Together we create and innovate for our customers' success

Find solutions from our partners to accelerate your next business opportunity. Infineon's global network of partners is an expert in designing products, solutions, and services leveraging Infineon components in 5 key domains: software, hardware, services, tools, and end applications.

The Infineon Partner Program is a global ecosystem of qualified companies, offering knowledge and experience to enable and implement Infineon products. Our associated, preferred, and premium partners help design your device and application based on our components. They have been carefully selected by us on the basis of their competence and ability to design and deliver strong and trustworthy solutions, especially for new technologies and use cases.

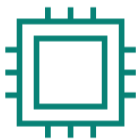

Hardware

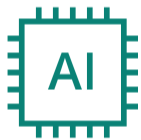

Software



Tools



Services



End applications

Partners manufacturing electronic components, demo boards, and turnkey modules

... jointly we create and commercialize value-added solutions, while reaching new buyers

Partners programming various types of software, algorithms, and operating systems

... jointly we enhance our portfolio with complementary components and expand technology know-how

Partners designing computer programs for the development of embedded systems

... jointly we enable a complete and immersive development experience for customers

Partners providing cloud and engineering services, application support or trainings

... jointly we build up engineering capabilities and offer them to a world class customer network

Partners creating end products and related applications

... jointly we provide customers with state-of-the-art solutions and innovative use cases

Find out more about the Infineon Partner Program, the latest news and solutions from our partners, and much more on our [Partner ecosystems webpage](https://www.infineon.com/partners).

Looking for a specific partner solution in your region? Our [partner finder](#) provides an overview of our partners and their offerings. Simply specify your search in the dropdown menu and browse through the companies and their solutions to navigate directly to the respective website for further information.

Additionally, use the "Partner solutions" tab on our product and application pages to find out more about Infineon's partner solutions.



Click here to learn more: [www.infineon.com/partners](https://www.infineon.com/partners)

Published by  
Infineon Technologies AG  
Am Campeon 1-15, 85579 Neubiberg  
Germany

© 2026 Infineon Technologies AG.  
All rights reserved.

**Public**

Version: V1.0\_EN  
Date: 05/2026



Stay connected!



Scan QR code and explore offering  
[www.infineon.com](http://www.infineon.com)